



HIGHER SCHOOL CERTIFICATE EXAMINATION

1996  
**PHYSICS**  
2 UNIT

*Time allowed—Three hours  
(Plus 5 minutes' reading time)*

**DIRECTIONS TO CANDIDATES**

- Board-approved calculators may be used.

**Section I—Core**

- Attempt ALL questions.
- **Part A** 15 multiple-choice questions, each worth 1 mark.  
Mark your answers in pencil on the Answer Sheet provided.
- **Part B** 10 questions, each worth 3 marks.  
Answer this Part in the Part B Answer Book.
- **Part C** 6 questions, each worth 5 marks.  
Answer this Part in the Part C Answer Book.
- Write your Student Number and Centre Number on each Answer Book.
- You may keep this Question Book. Anything written in the Question Book will NOT be marked.

**Section II—Electives**

- Attempt ONE question.
- Each question is worth 25 marks.
- Answer each Elective or Half-elective in a *separate* Elective Answer Book.
- Write your Student Number and Centre Number on the cover of each Elective Answer Book.
- Write the Course, Elective Name, and Question Number on the cover of each Elective Answer Book.
- You may ask for extra Elective Answer Books if you need them.

A Data Sheet and Periodic Table are provided as a tear-out sheet at the back of this paper.

## SECTION I—CORE

(75 Marks)

Attempt ALL questions.

### PART A

Questions 1–15 are worth 1 mark each.

Mark your answers in pencil on the Answer Sheet provided.

Select the alternative A, B, C, or D that best answers the question.

1. The diagram below shows the height versus time of tides in Sydney.

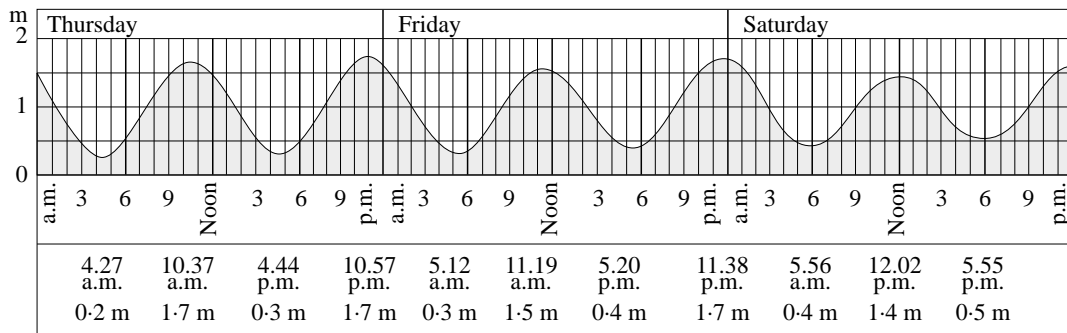

The type of motion that this graph best represents is

- (A) projectile motion.
- (B) a bouncing ball.
- (C) simple harmonic motion.
- (D) uniformly accelerated motion.

2. A mass of 2.5 kg is acted on by four forces in the same plane as shown below.

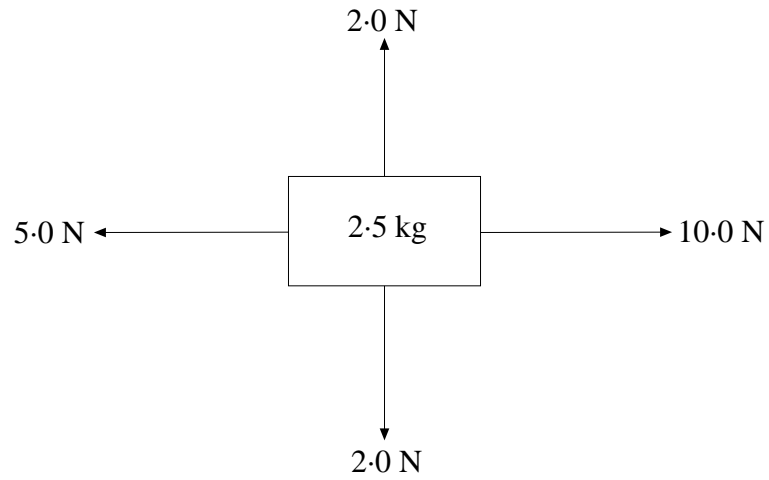

The magnitude of the acceleration of the mass will be closest to

- (A)  $2.0 \text{ m s}^{-2}$
- (B)  $4.0 \text{ m s}^{-2}$
- (C)  $5.0 \text{ m s}^{-2}$
- (D)  $7.6 \text{ m s}^{-2}$

3. A boy swings a plastic bucket of water in a vertical circular path over his head, as shown.

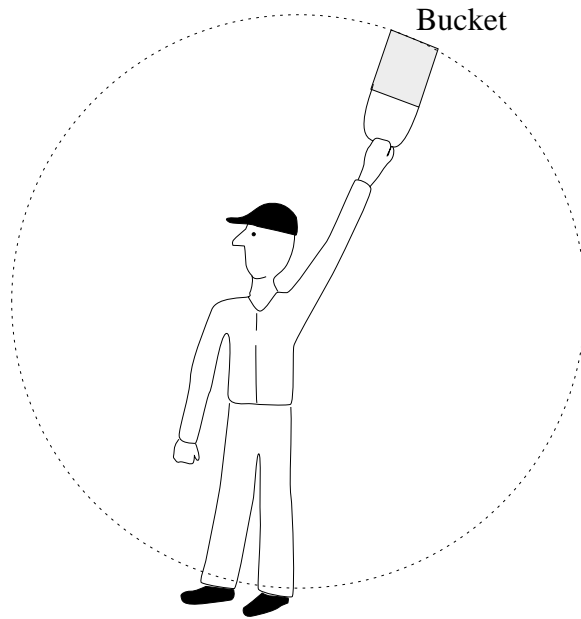

When the bucket of water is near the top of the circle, the water does not fall out because

- (A) gravity does not act on the water inside the bucket when it is being rotated.
  - (B) the water has no weight at the top of the circle.
  - (C) a force pulls the water outwards towards the bottom of the bucket.
  - (D) the bucket and the water are accelerating at the same rate.
4. The Moon has a mass of  $7.2 \times 10^{22}$  kg. It moves round the Earth at a distance of  $3.8 \times 10^8$  m. Its speed round the Earth is  $1.0 \times 10^3$  m s<sup>-1</sup>.

The gravitational force of the Earth on the Moon is

- (A)  $7.0 \times 10^{23}$  N
- (B)  $1.9 \times 10^{20}$  N
- (C)  $2.7 \times 10^{-3}$  N
- (D)  $4.8 \times 10^{-6}$  N

5. A car moves round a horizontal circular track with a constant speed. Points  $X$  and  $Y$  are on opposite sides of the track.

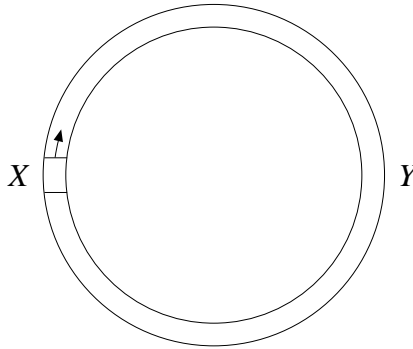

One of the statements below is *incorrect*.

Choose the statement that is NOT correct.

- (A) At point  $X$  on the track, the acceleration of the car is zero.
- (B) Over one complete revolution of the circuit (from  $X$  to  $Y$  and back again to  $X$ ) the average velocity of the car is zero.
- (C) Over one complete revolution of the circuit (from  $X$  to  $Y$  and back again to  $X$ ) the displacement of the car is zero.
- (D) In moving from point  $X$  to point  $Y$ , the change of speed of the car is zero.

6. Air bags and crumple zones extend collision times and therefore decrease the forces exerted on passengers during car accidents.

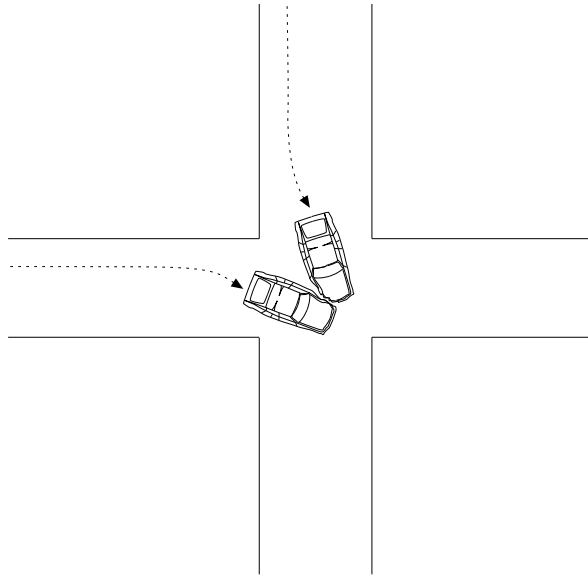

When colliding cars are brought to a stop during a collision, the total amount of kinetic energy changed to other forms of energy

- (A) is increased by air bags and crumple zones.
- (B) is decreased by air bags and crumple zones.
- (C) is unchanged by air bags and crumple zones.
- (D) will depend on whether both cars possess air bags or crumple zones.

7. A stationary object with a mass of  $6.0 \text{ kg}$  explodes into three pieces. The magnitude of the momentum of the first piece is  $3.0 \text{ kg m s}^{-1}$  and the magnitude of the momentum of the second piece is  $4.0 \text{ kg m s}^{-1}$ . These pieces move at right angles to one another as shown below.

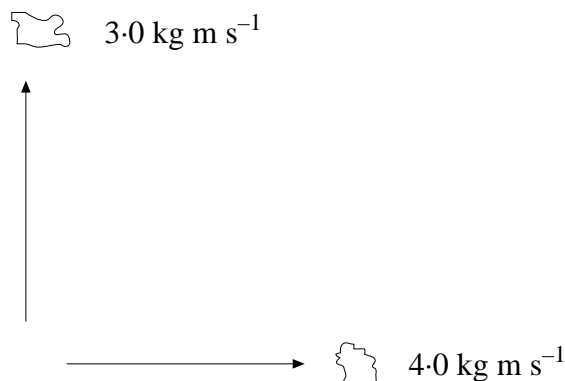

The magnitude of the momentum of the third piece is

- (A)  $2.5 \text{ kg m s}^{-1}$   
(B)  $3.7 \text{ kg m s}^{-1}$   
(C)  $4.5 \text{ kg m s}^{-1}$   
(D)  $5.0 \text{ kg m s}^{-1}$
8. A bullet bounces off a metal can. During the collision, the bullet exerts a force on the can, causing it to move. At the same time, the can exerts a force on the bullet, causing it to slow down and change direction.
- Which of the following statements best describes the relationship between the magnitudes of these two forces?
- (A) The force of the bullet on the can is larger than the force of the can on the bullet.  
(B) The force of the bullet on the can is smaller than the force of the can on the bullet.  
(C) The force of the bullet on the can is equal to the force of the can on the bullet.  
(D) The relationship between the two forces depends on the angle of impact.
9. When an electron, in an electric circuit, moves through a potential drop of 5 volts, the electron undergoes an energy change of
- (A) 5 joules.  
(B) 5 joules/coulomb.  
(C) 5 amps.  
(D) 5 volts/amp.

10. A light globe glows brightly in a simple circuit as shown.

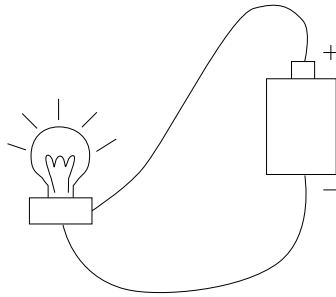

Which of the following diagrams correctly shows the directions in which the actual charges move in the wires of the circuit?

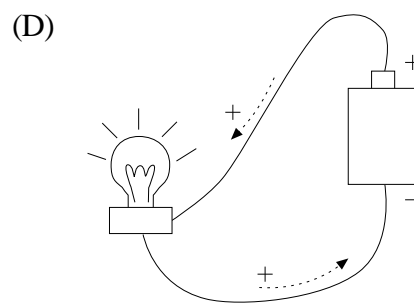
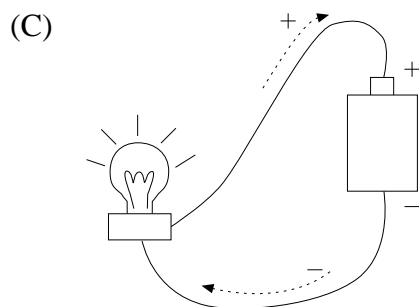
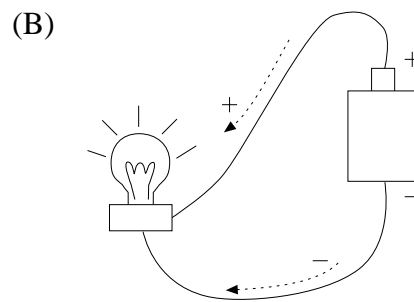
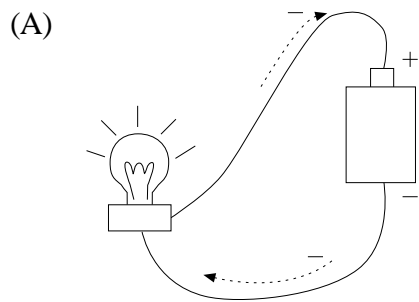



11. Two parallel wires carry currents in the same direction. The wires are viewed from the ends as shown in the diagram.

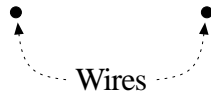

Which of the following diagrams best represents the magnetic field in the region near the wires?

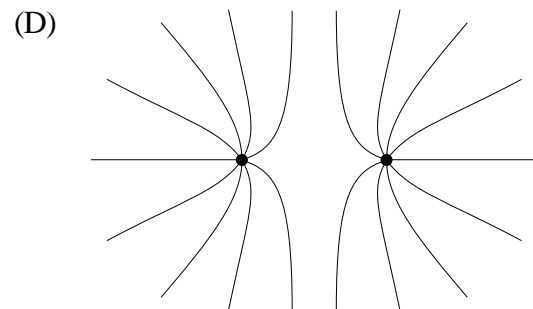
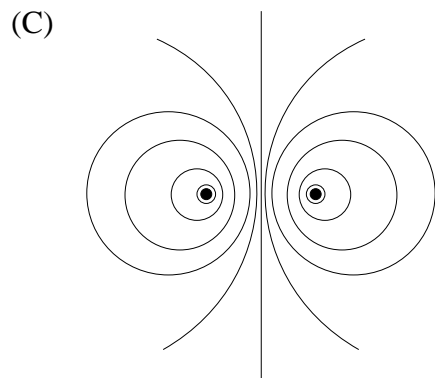
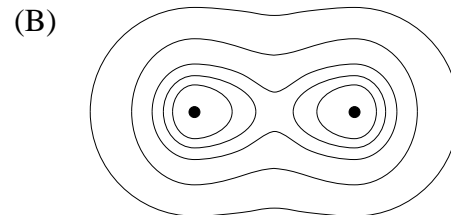
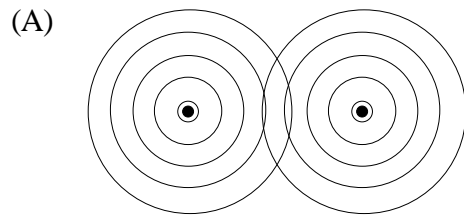

12. A thin metal rod was placed between the poles of a magnet. A current was passed through the rod. This current caused the rod to move vertically upwards.

Which of the following diagrams correctly shows the direction of the current,  $I$ , and the position of the rod in the magnetic field?

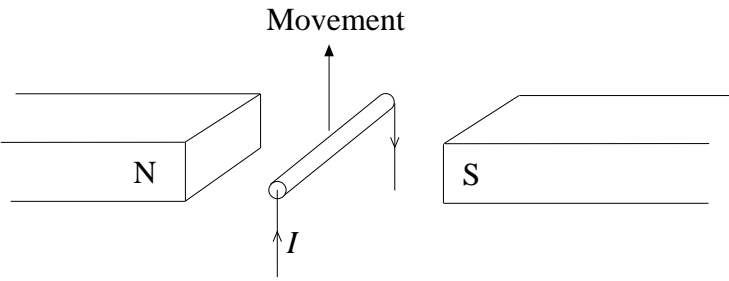
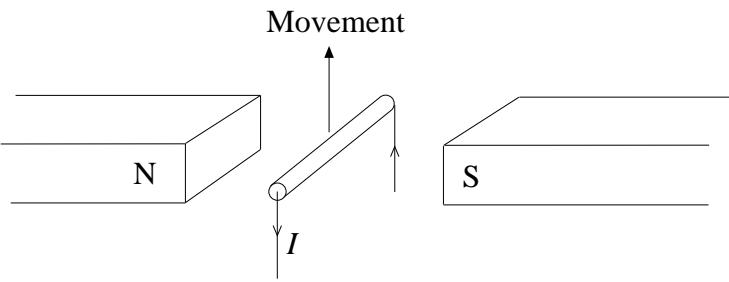
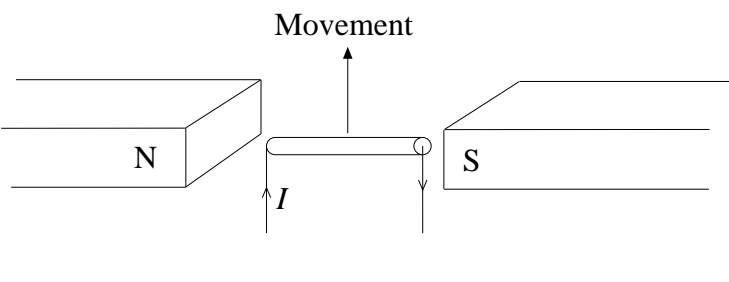
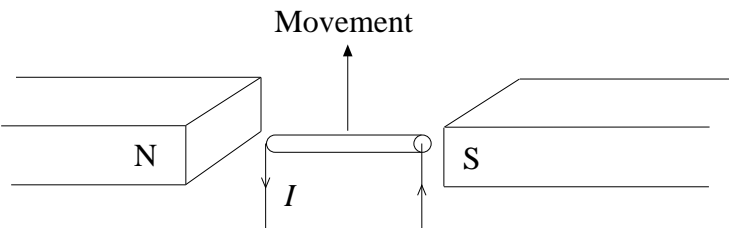
- (A) 
- (B) 
- (C) 
- (D) 

13. A horizontal wire,  $XY$ , is moving into a magnetic field in a direction perpendicular to its length, as shown below. The speed of the wire is  $2.5 \text{ m s}^{-1}$ . The magnetic field points directly out of the paper and its flux density is  $0.48 \text{ T}$ .

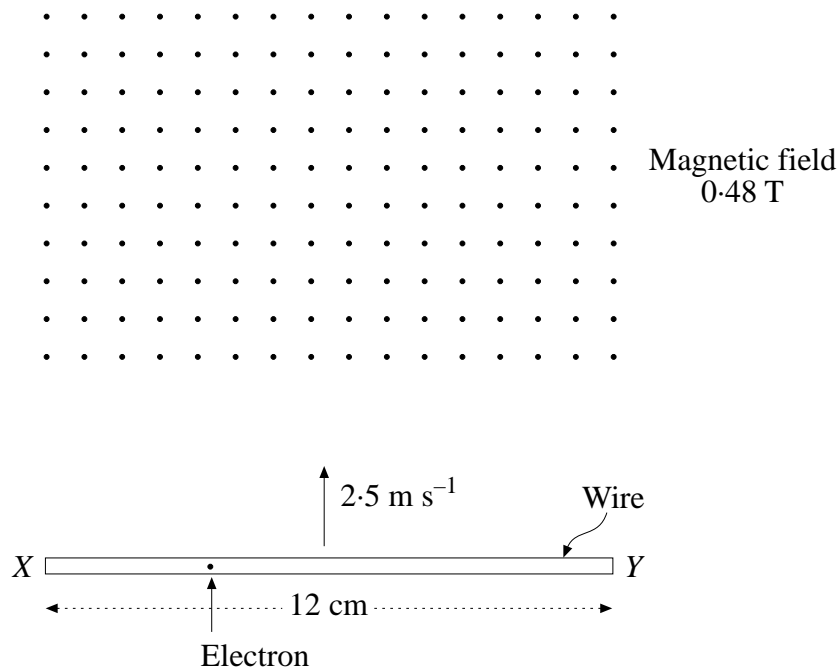

The magnitude and direction of the magnetic force on an electron in the wire when it first enters the magnetic field is

- (A)  $1.9 \times 10^{-19} \text{ N}$  towards the left.  
 (B)  $1.9 \times 10^{-19} \text{ N}$  towards the right.  
 (C)  $9.2 \times 10^{-22} \text{ N}$  towards the left.  
 (D)  $9.2 \times 10^{-22} \text{ N}$  towards the right.

14. A longitudinal standing wave is set up in the air in a tube that is closed at one end. At a particular instant of time, the positions of a row of particles along the axis of the tube are shown in the following diagram. The particles in the row were initially evenly spaced.

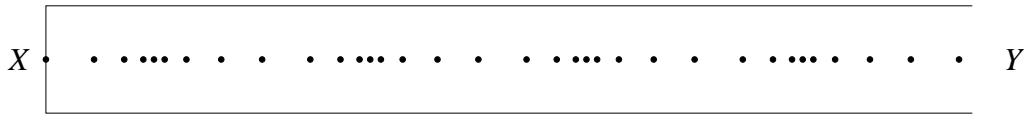

Which of the following diagrams best represents the displacement of the particles in the tube from their undisturbed positions?

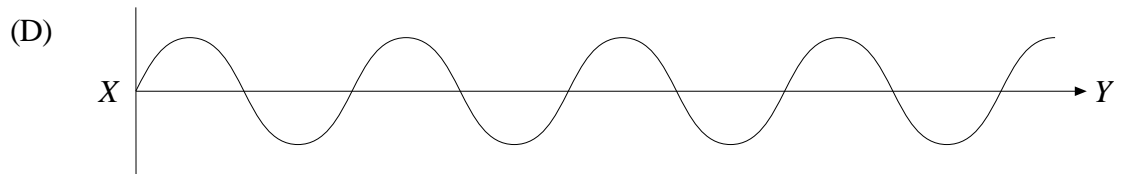
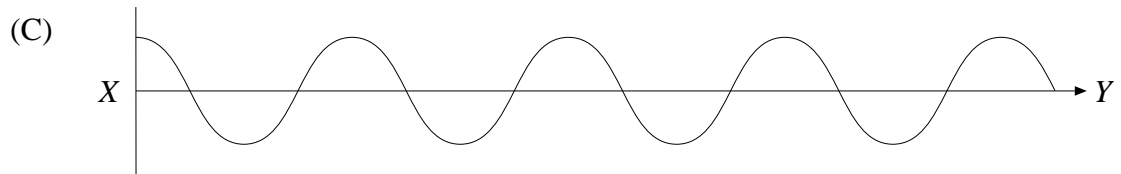
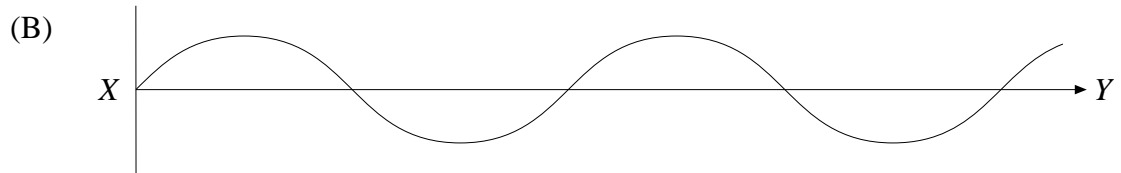
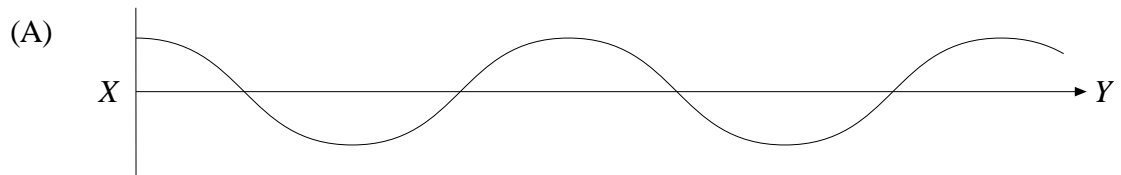

15. The diagram below shows a pattern of water waves in a ripple tank. The depth of water is the same throughout the tank.

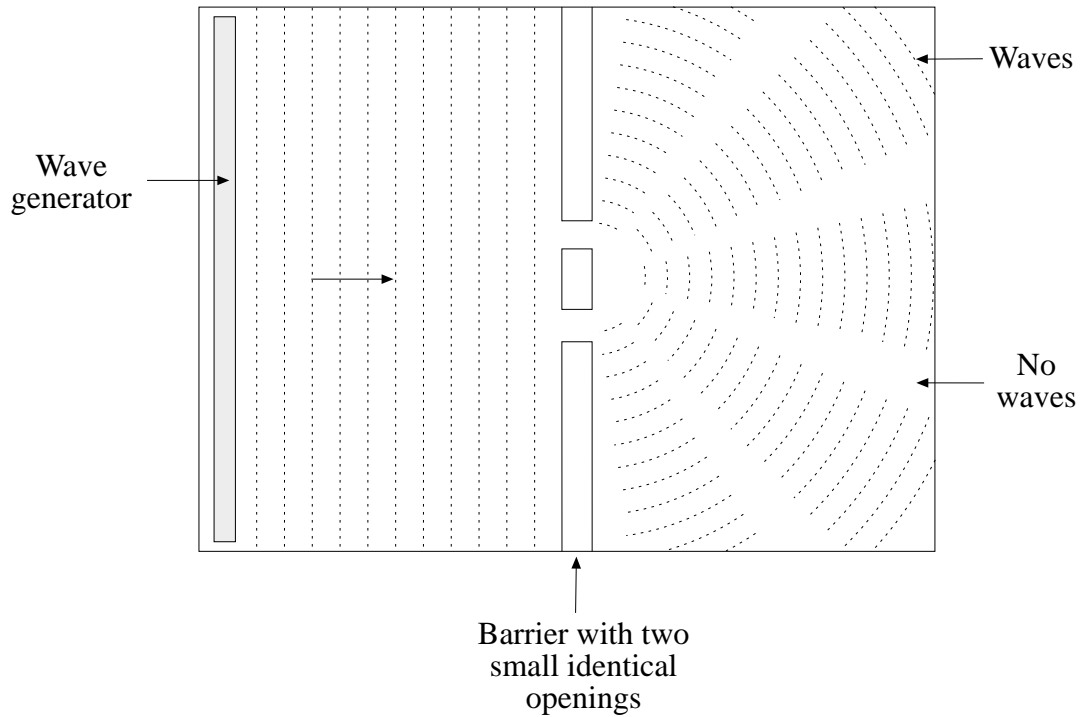

Which two aspects of wave behaviour best explain the pattern on the right-hand side of the barrier?

- (A) diffraction and reflection
- (B) interference and refraction
- (C) diffraction and interference
- (D) refraction and diffraction

**PART B**

Questions 16–25 are worth 3 marks each.

Answer this Part in the Part B Answer Book.

Show all necessary working.

Marks may be awarded for relevant working.

- 16.** A mass hangs on a spring. It is pulled down from position  $Z$  and released so that it oscillates up and down between  $X$  and  $Y$  as shown.

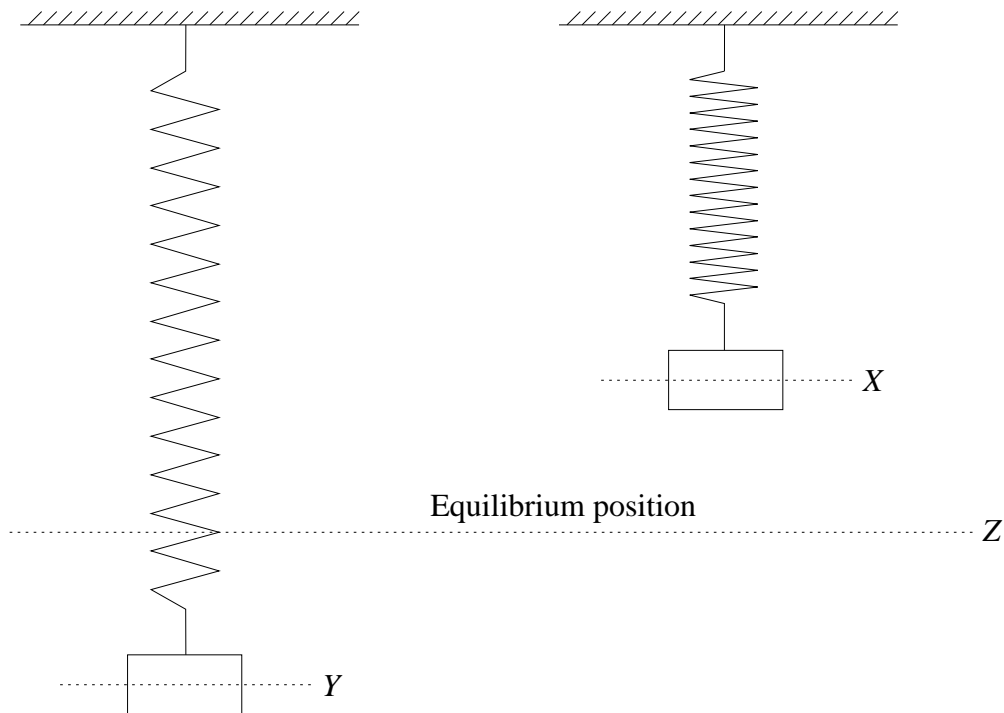

- (a) This oscillation is often described as ‘non-uniform’. Explain briefly what this means.
- (b) Describe the velocity and acceleration of the mass when it is at point  $Y$  during one of the oscillations.

17. A police car is travelling west with a constant velocity of  $16 \text{ m s}^{-1}$ . The police in the car use a new type of radar to measure the velocity of a bus travelling due north.

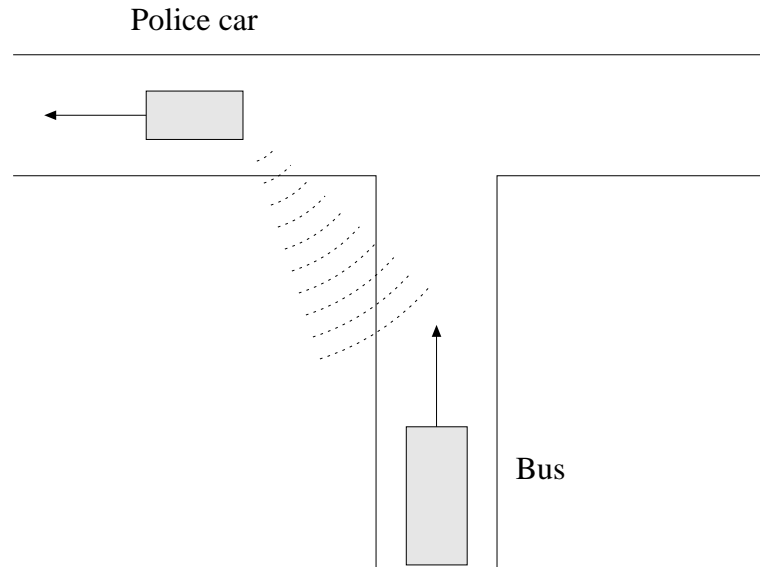

They find that the velocity of the bus relative to the police car is  $22 \text{ m s}^{-1}$ .

- Sketch a labelled vector diagram, showing how the velocity of the bus relative to the ground can be found.
- Determine the velocity of the bus relative to the ground.

18. A small sphere is held in a fixed position by a fine silk thread and the force due to a charged Perspex rod, as shown in the diagram.

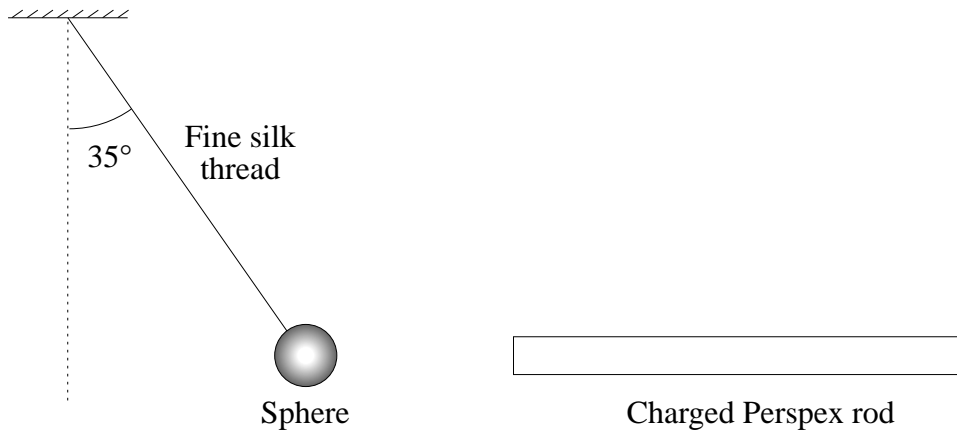

Three forces, the weight ( $W$ ) of the sphere, the tension ( $T$ ) in the thread, and the electrostatic force ( $F$ ) due to the charged rod, act on the sphere.

- (a) On the diagram in the Answer Book, draw labelled arrows to show the direction of each of the THREE forces acting on the sphere.
- (b) If the mass of the sphere is  $2.00 \times 10^{-3}$  kg, calculate the magnitude of the electrostatic force,  $F$ .
19. Two students, Ahmed and Michael, on a physics excursion to a local skating rink, collide on the ice. They fall over and continue to slide together, hanging onto each other. Ahmed has a mass of 42 kg and was moving south-west at  $1.5 \text{ m s}^{-1}$  before the collision. Michael has a mass of 55 kg and was moving south at  $2.0 \text{ m s}^{-1}$  before the collision.

Determine the magnitude and direction of the velocity, immediately after the collision, of the two skaters as they slide together as one.



20. A 4.0 ohm and a 2.0 ohm resistor are connected in series with a 12 volt power supply. A variable resistor,  $R_v$ , is placed in parallel with the other two resistors, as shown.

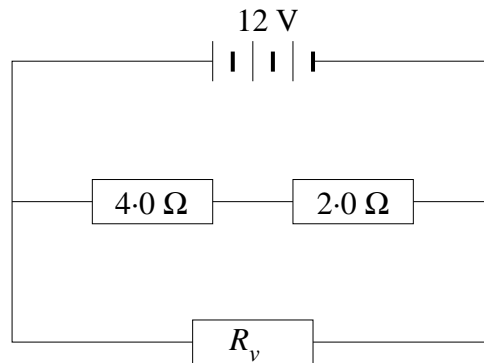

The current in the variable resistor is 3.0 amps.

- Calculate the resistance of the variable resistor.
  - Calculate the current flowing through the 4.0 Ω resistor.
  - Calculate the potential difference across the 2.0 Ω resistor.
21. Static eliminators reduce the build-up of static electricity on the surface of objects. In one such device, radioactive polonium-210 emits a constant stream of alpha particles at the rate of 40 000 particles every 60 seconds. This stream of particles passes near a surface, neutralising it.
- How can this stream of alpha particles neutralise the charge on the surface?
  - The stream of alpha particles can be considered to be an electric current. What is the magnitude of this current?
22. (a) A crane using an electromagnet to lift iron objects first raises a 2-tonne crushed car to a height of 16 m and then moves it sideways.
- List TWO factors that determine the magnitude of the flux density at the centre of the electromagnet.
- While the crane is moving the car horizontally, the current in the electromagnet is accidentally cut and immediately the car falls.
- Calculate how long it will take the car to reach the ground.

23. A wire carries a current of 12 A as shown.

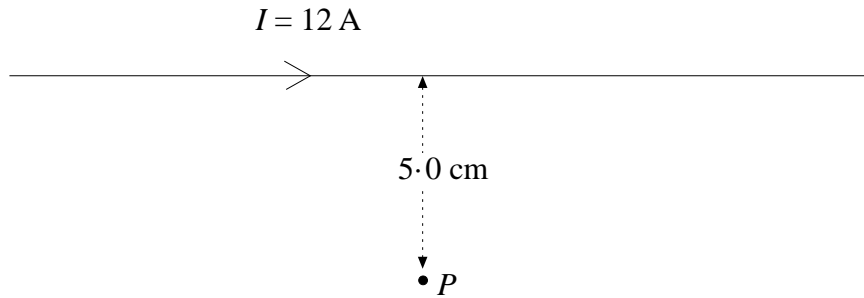

- (a) Calculate the magnitude and direction of the magnetic flux density at a point  $P$ , 5.0 cm from the wire, given that Ampère's constant,  $k$ , is  $2.0 \times 10^{-7} \text{ N s}^2 \text{ C}^{-2}$ .
- (b) A second wire, parallel to the first one and of length 15 cm, passes through the point  $P$ . It carries a current of 4.0 A. Calculate the magnitude of the magnetic force that acts on the second wire.
24. A proton is projected with a velocity of  $v \text{ m s}^{-1}$  into a uniform magnetic field of flux density  $B$  tesla. The field is directed out of the page as shown.

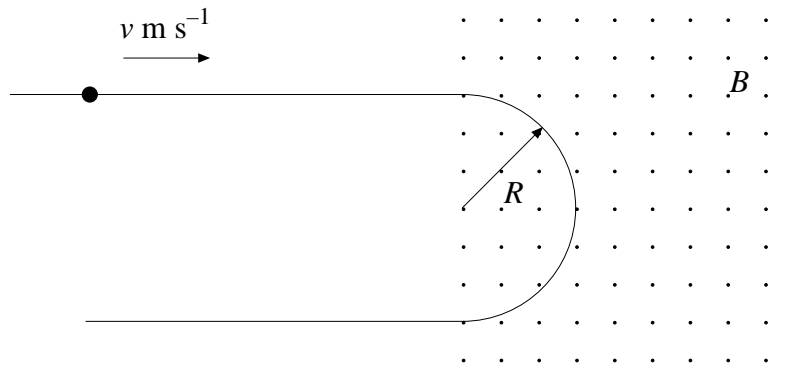

The proton travels along a semicircular path and then leaves the region of the magnetic field.

- (a) Explain why the path in the magnetic field has the shape shown.
- (b) The magnetic flux density is now halved, without reducing the region of space covered. On the diagram in your Answer Book, sketch the path of the proton.

25. Sound waves from a loudspeaker strike a thick concrete wall as shown. Some of the sound is reflected, and some passes through the wall.

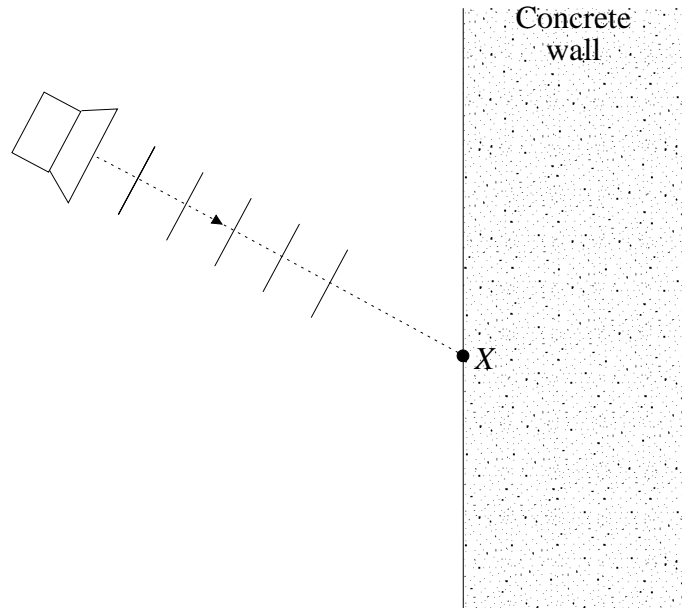

- (a) On the diagram in your Answer Book, draw in a series of reflected wavefronts.
- (b) The speed of sound in the wall is greater than its speed in air. On the diagram in your Answer Book, draw a series of wavefronts to represent the sound travelling inside the wall.

**PART C**

Questions 26–31 are worth 5 marks each.

Answer this Part in the Part C Answer Book.

Show all necessary working.

Marks may be awarded for relevant working.

- 26.** A ball is thrown horizontally from the top of a cliff 40.0 m high. The position of the ball is shown at five points on its path. Position 1 is the point where it leaves the thrower's hand. The time interval in moving from any position to the next is 0.3 seconds. The diagram is not to scale. Air resistance is negligible.

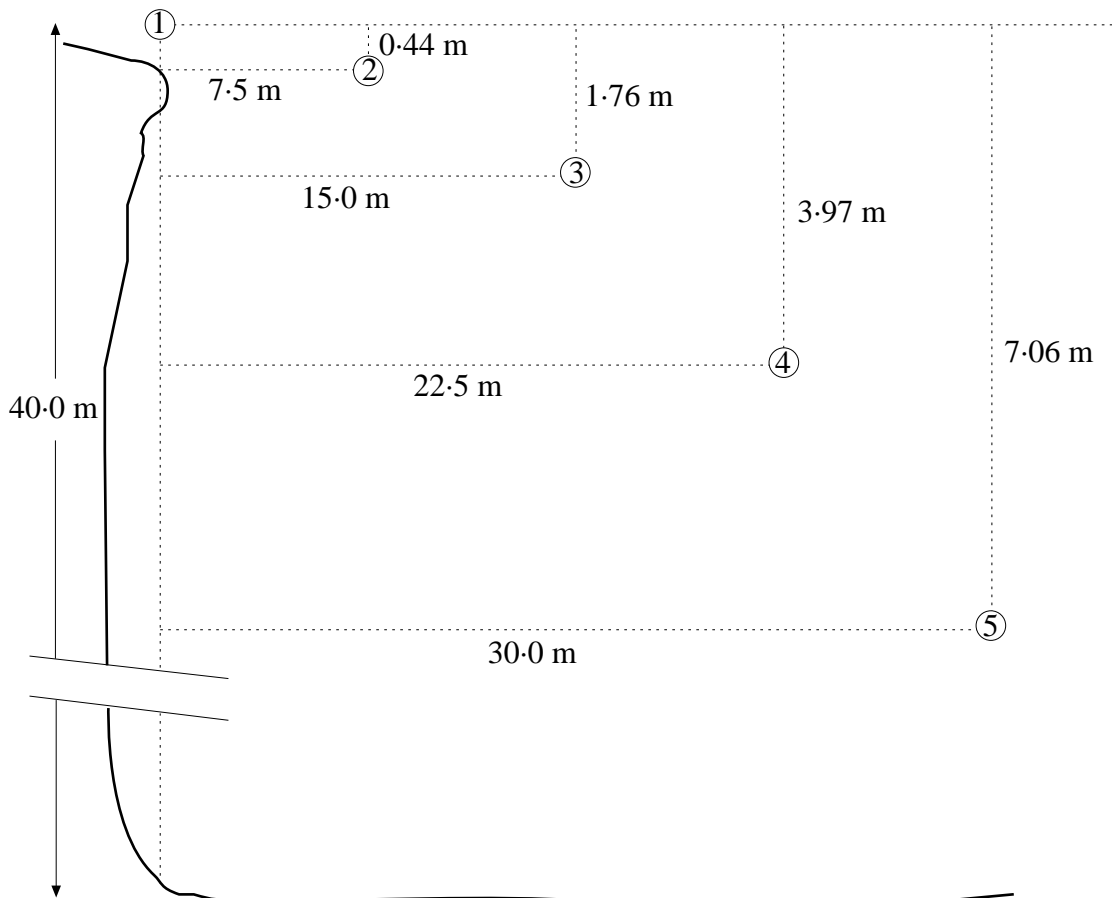

- Explain why the horizontal displacement of the ball changes as it does.
- Explain why the vertical displacement of the ball changes as it does.
- How far from the bottom of the cliff does the ball land?
- Determine the magnitude of the velocity of the ball immediately before it hits the ground.

27. A block, *A*, of mass 2.0 kg is placed on an inclined plane as shown. The plane makes an angle of  $25^\circ$  with the horizontal. The block is connected to a second block, *B*, of mass 4.0 kg by a light, inextensible string which passes over a frictionless pulley.

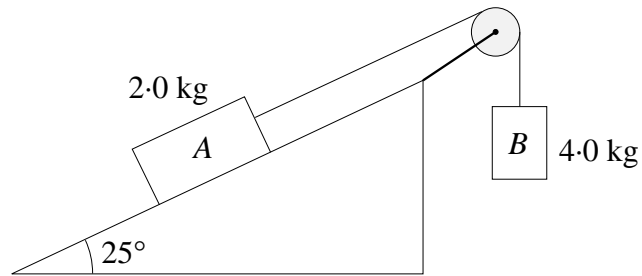

The masses are released and begin to move without any frictional resistance.

- Calculate the magnitude of the acceleration of the masses.
- Calculate the tension in the string. Show all working.
- When block *A* is replaced by another block, *C*, of the same mass, 2.0 kg, the measured acceleration is found to be  $3.0 \text{ m s}^{-2}$ . Calculate the frictional resistance on block *C*.

28. The diagram below shows an elastic collision between two objects, *A* and *B*. The collision takes place in a horizontal plane.

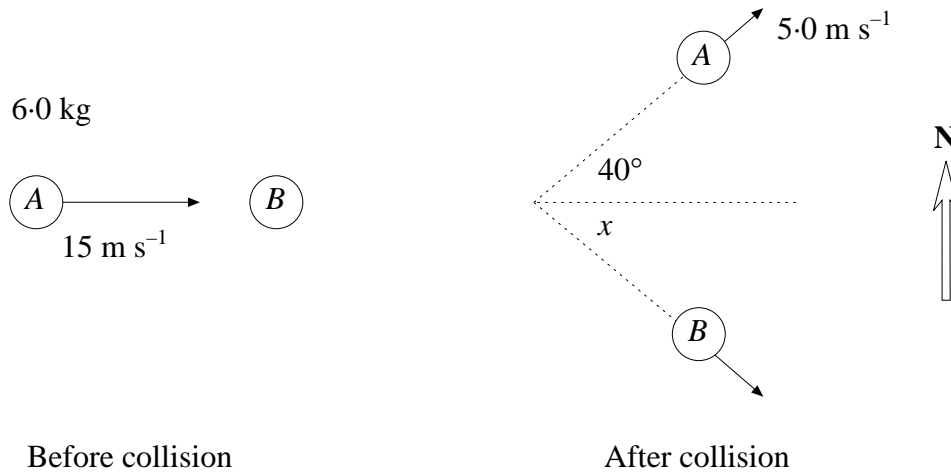

Object *A* has a mass of 6.0 kg. Before the collision, it is travelling towards the east at a speed of 15 m s<sup>-1</sup>. Object *B* is at rest before the collision.

After the collision, object *A* moves at a speed of 5.0 m s<sup>-1</sup> in a direction at 40° to its original direction.

- Calculate the kinetic energy of object *B* after the collision.
- Calculate the southerly component of the momentum of object *B* after the collision.
- The easterly component of the momentum of object *B* is 67 kg m s<sup>-1</sup>. Calculate the angle *x*.
- Calculate the momentum of object *B* after the collision.
- Using your answers to parts (a) and (d), calculate the speed of object *B* after the collision.

29. In a practical assessment task, a student is asked to set up a circuit to determine the resistance of a light globe.

The student sets up the circuit shown and closes the switch to measure the current and voltage.

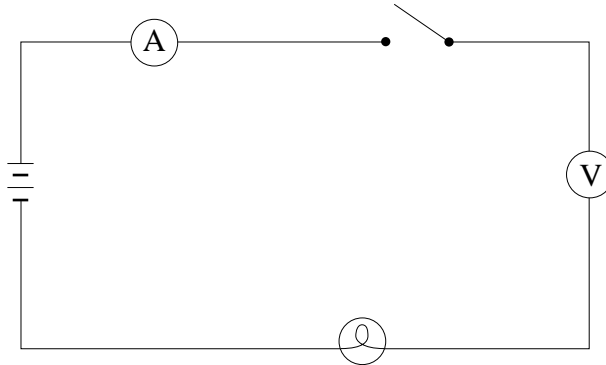

- Complete the table in your Answer Book by writing in the names of the components shown.
- There is *one* serious error in the student's circuit. Using the same components, and as many leads as necessary, draw the correct circuit diagram in your Answer Book.
- With the circuit correctly wired, the student obtains a voltmeter reading of 7.5 V and an ammeter reading of 0.46 A. Calculate the resistance of the globe.
- Describe how a student should connect a second light globe to show that an increase in total resistance causes the current to decrease.

30. Two large bar magnets and a vertical coil are shown in the diagram.

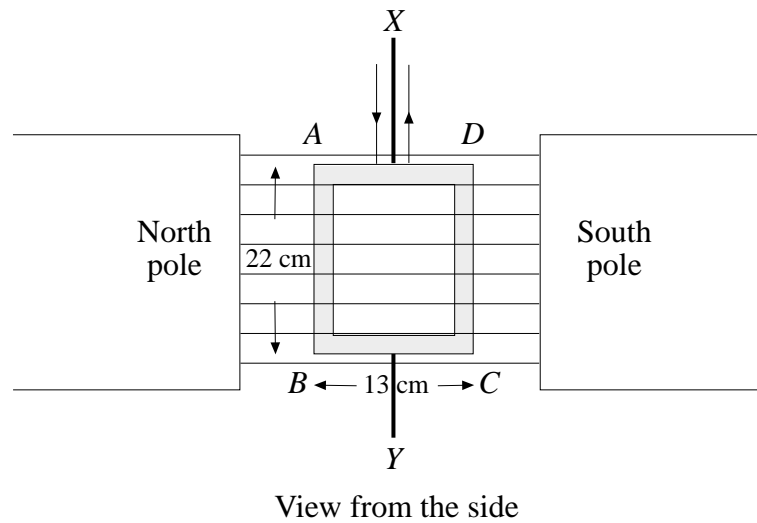

The coil,  $ABCD$ , is able to rotate about a vertical axle,  $XY$ , through its centre. The coil consists of 140 turns of wire. Current can flow into and out of the coil along wires attached to the upper end of the axle.

The coil is 22 cm high and 13 cm wide. The magnetic flux density between the poles of the magnets is 0.80 tesla.

- Before the current in the coil is turned on, what is the flux through the coil when the plane of the coil is parallel to the field?
- When a current of 3.0 A flows through the coil, calculate the magnitude of the force on side  $AB$  of the coil.
- Calculate the torque on the coil when the plane of the coil is at an angle of  $35^\circ$  to the magnetic flux as shown below.

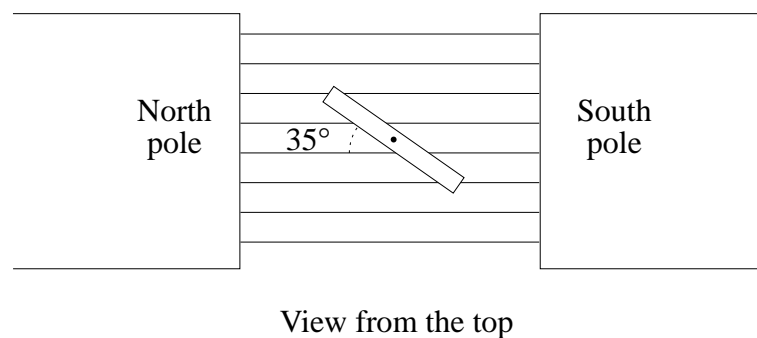

- If the magnets and the coil described above are used as the basis for an electric meter, what should be added to cause the coil to stop at the correct position to indicate the current?
- If the magnets and the coil described above are used as the basis for an electric motor, what should be added to allow the coil to keep rotating in the same direction?



- 31.** A string is stretched between two points 0.80 m apart. When plucked, the string can produce notes of different frequencies.
- (a) What type of wave is produced in the string when it is plucked?
  - (b) Calculate the wavelength of the fundamental vibration of the string.
  - (c) If the frequency of the fundamental is 200 Hz, calculate the velocity of the wave in the string.
  - (d) In your Answer Book, sketch the wave pattern in the string that would produce the vibration with the third lowest frequency (the third harmonic).
  - (e) If the speed of sound in air is  $340 \text{ m s}^{-1}$ , calculate the minimum length of a tube open at both ends that would produce a vibration with a frequency of 200 Hz.

**SECTION II—ELECTIVES**

(25 Marks)

Attempt ONE question.

Each question is worth 25 marks.

Answer each Elective or Half-elective in a *separate* Elective Answer Book.

Show all necessary working.

Marks may be awarded for relevant working.

	Page
<b>HISTORY OF IDEAS IN PHYSICS</b>	
Gravitation .....	27
Nature of Light .....	30
Atomic Structure .....	32
<b>WAVE PROPERTIES OF LIGHT</b> .....	34
<b>ROTATION</b> .....	38
<b>PHYSICS IN TECHNOLOGY</b>	
Engineering Materials and Structures .....	42
Optical Instruments .....	44
Transformation of Energy .....	45
<b>ASTRONOMY</b> .....	47

**QUESTION 32. History of Ideas in Physics (25 marks)****Marks**

If you are attempting this elective, you must do TWO half-electives.

Answer each half-elective in a *separate* Elective Answer Book.

**A. Half-elective: Gravitation (12½ marks)**

- (a) As viewed from the Earth, the path of Mars as it moves against the background stars during a time interval of 192 days is shown in the diagram. 4

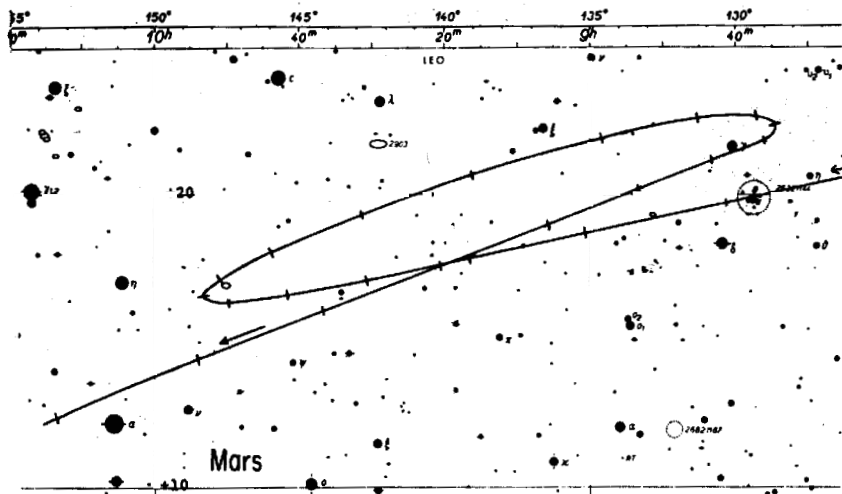

- (i) How can this apparent motion of Mars be explained using a geocentric model?
- (ii) Using a heliocentric model, explain why the planet does not appear to move in one direction all the time.

QUESTION 32. (Continued)

Marks

(b) Aristarchus (about 310–230 BC) and Copernicus (AD 1473–1543) both advocated a heliocentric model of the solar system. 3½

- (i) Describe ONE major difference between the models of Aristarchus and Copernicus.
- (ii) Give ONE reason why Aristarchus’s model was generally rejected by people of his time.
- (iii) The following are Galileo’s drawings of the positions of the four moons of Jupiter, as he observed them over a period of some weeks.

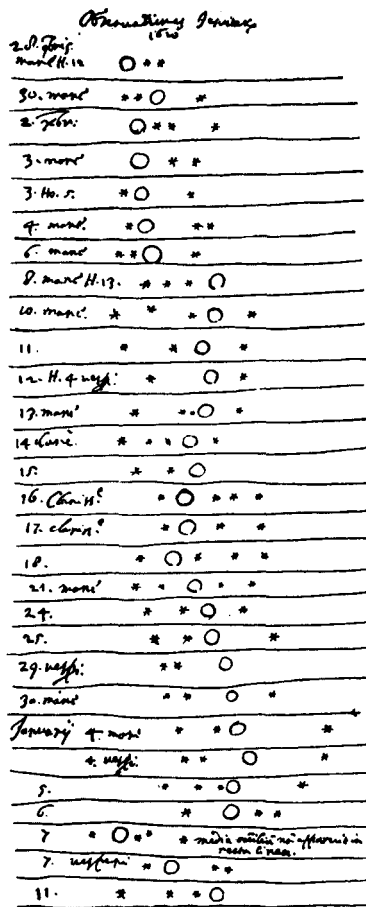

Explain why Galileo believed that these observations provided evidence in support of Copernicus’s heliocentric model of the solar system.

(c) Using clearly labelled diagrams, explain the difference between an ‘eccentric’ and an ‘equant’ in Ptolemy’s model of the solar system. 2

## QUESTION 32. (Continued)

Marks

- (d) (i) The following table contains information about two planets, Uranus and Pluto, that were discovered after Kepler died. 3

<i>Planet</i>	<i>Orbital period</i> (years)	<i>Average distance</i> <i>from the Sun</i> (km)
Uranus	84.0	$2.87 \times 10^9$
Pluto	248.4	$5.91 \times 10^9$

Show that the information is consistent with Kepler's third law (his law of periods).

- (ii) If the mass of Pluto is  $1.3 \times 10^{22}$  kg and its radius is  $2.3 \times 10^6$  m, determine the acceleration due to gravity on the surface of Pluto.
- (iii) Explain the significance of the word *universal* in 'Newton's law of universal gravitation'.

## QUESTION 32. (Continued)

Marks

Answer this half-elective in a *new* Elective Answer Book.

**B. Half-elective: Nature of Light** ( $12\frac{1}{2}$  marks)

- (a) Diagrams A and B represent two different models that have been used to explain the behaviour of light. Each diagram shows incident and reflected light at an air/glass boundary. 4

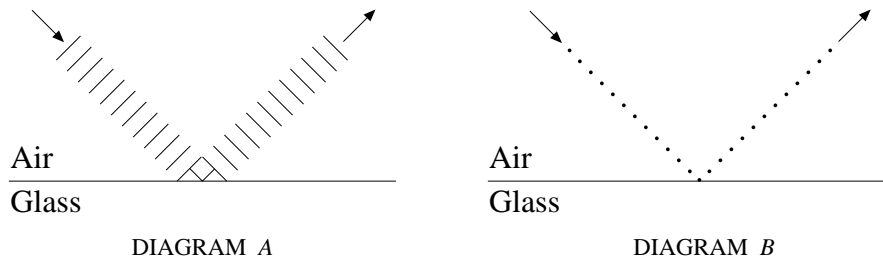

- (i) Which diagram best represents the model proposed by Isaac Newton? Give your reasons for choosing this diagram.
- (ii) In your Answer Book, sketch corresponding diagrams to show Newton's and Huygens's representation of refraction at an air/glass interface.
- (b) In your study of the history of ideas about the nature of light, you learnt about some historically important experiments on interference of light carried out by Fresnel. 4

Select ONE such experiment.

- (i) Using a carefully labelled diagram, describe the experiment.
- (ii) State the outcome of the experiment, and describe what it showed about the nature of light.

## QUESTION 32. (Continued)

Marks

- (c) The diagram below illustrates apparatus that can be used to show the photoelectric effect. 4½

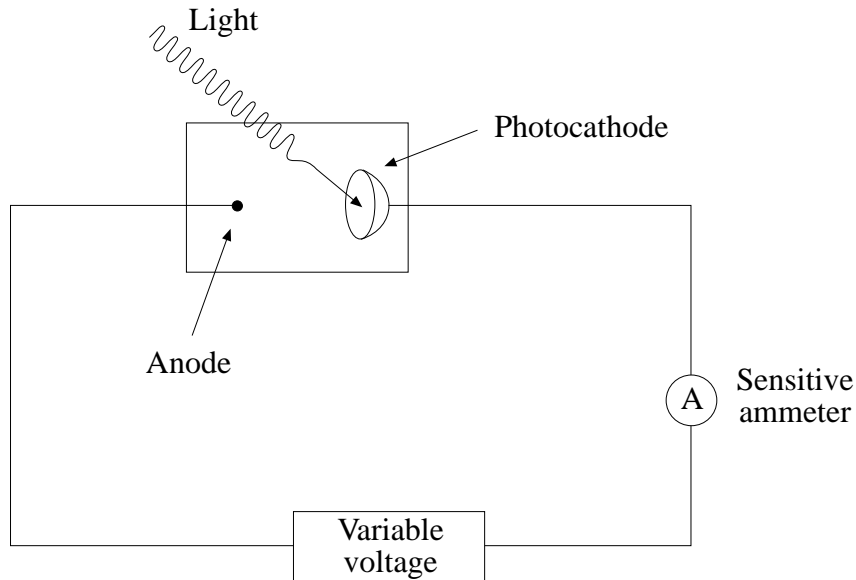

- (i) Describe ONE similarity between the ideas of Planck and Maxwell about the nature of the incident light on the photocathode.
- (ii) Describe ONE similarity between the ideas of Planck and Einstein about the nature of the incident light on the photocathode.
- (iii) Below a certain frequency, increasing the intensity of the incident light has no effect on the photocurrent in the circuit.
  1. As the intensity of light on the photocathode increases, what would be expected, on the basis of the wave model, to happen to the current in the circuit ?
  2. How does the photon model explain the actual result?

## QUESTION 32. (Continued)

Marks

Answer this half-elective in a *new* Elective Answer Book.

**C. Half-elective: Atomic Structure** ( $12\frac{1}{2}$  marks)

- (a) What did early Greek philosophers mean when they used the word ‘atom’? **1**
- (b) Experiments involving electrical discharges through gases highlighted the electrical nature of matter, and helped to develop new ideas about the atom. However, at atmospheric temperatures and pressures, gases such as those in air are poor conductors. **4**
- (i) How did Heinrich Geissler help to overcome this problem?
  - (ii) Describe ONE gas-discharge tube experiment that advanced the understanding of the atom.
  - (iii) How did the experiment that you described in part (ii) contribute to our understanding of the nature of the atom.
- (c) (i) How did the results of the Geiger–Marsden experiment help Rutherford develop the model of the nuclear atom? **4**
- (ii) Describe TWO problems associated with electron orbits in Rutherford’s model that were overcome by Bohr’s quantised orbits.



## QUESTION 32. (Continued)

Marks

- (d) The diagram below shows some of the energy levels for the electron in the hydrogen atom. 3½

		<i>Energy</i>
$n = \infty$	_____	0
$n = 5$	_____	$-0.87 \times 10^{-19} \text{ J}$
$n = 4$	_____	$-1.36 \times 10^{-19} \text{ J}$
$n = 3$	_____	$-2.41 \times 10^{-19} \text{ J}$
$n = 2$	_____	$-5.43 \times 10^{-19} \text{ J}$
$n = 1$	_____	$-21.7 \times 10^{-19} \text{ J}$

- (i) Calculate the frequency of light produced by an electron dropping from the fourth to the second energy level.
- (ii) Name ONE instrument that you could use to measure the wavelength calculated.
- (iii) Describe ONE way in which the model of the Bohr atom for hydrogen helps us to understand other atoms of the Periodic Table.

**QUESTION 33. Wave Properties of Light (25 marks)****Marks**

- (a) The seventeenth century scientist, Christian Huygens, suggested that the propagation of wavefronts of light through a medium could be understood by regarding every point along the wavefront as a source of secondary wavelets. **1**

Calculate the radius of ONE such secondary wavelet 50 ns (nanoseconds) after it forms in air.

- (b) A ray of light of wavelength 650 nm is incident on a  $60^\circ$  triangular prism. Inside the prism, the ray travels parallel to the base as shown. The angle of incidence is  $40^\circ$ . **5**

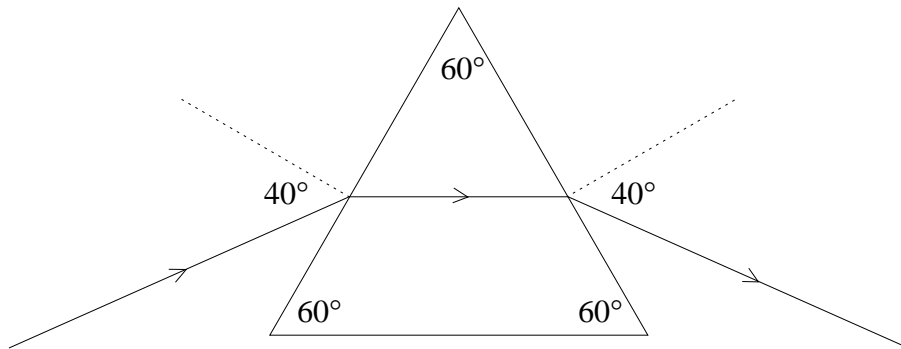

- (i) Calculate the refractive index of the material.
- (ii) Calculate the velocity of light in the prism.
- (iii) A different light ray enters the prism along the same path, but emerges from the prism at a different angle to the first ray. Explain why this happens.

## QUESTION 33. (Continued)

Marks

- (c) A tanker accidentally spills benzene into Sydney Harbour. The refractive index of benzene is 1.50, and the refractive index of water is 1.33. A small cross-section of the spill is illustrated in the diagram below. 5

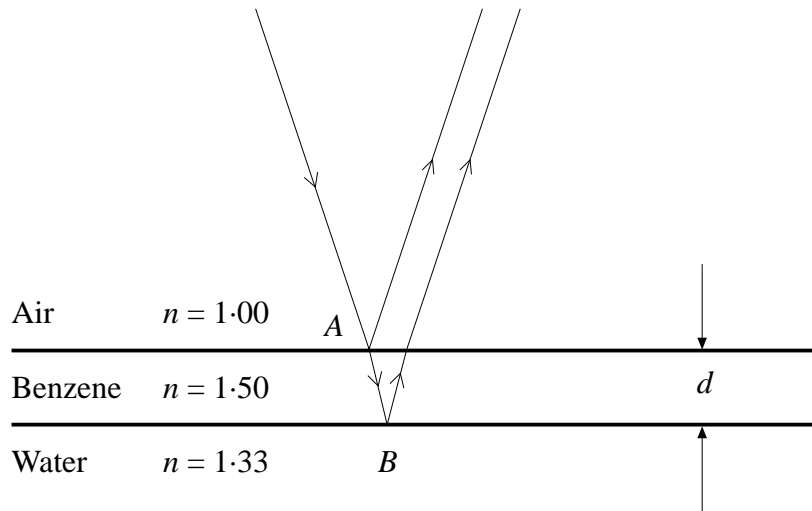

The film of benzene is illuminated from directly overhead by light from a sodium lamp with a wavelength of 590 nm.

- (i) Calculate the wavelength of the light in the benzene.
- (ii) Describe the phase changes (if any) that occur when the light reflects:
  1. from point A;
  2. from point B.
- (iii) Calculate the minimum thickness,  $d$ , of the benzene film that will produce *constructive* interference of the two reflected beams shown in the diagram.

## QUESTION 33. (Continued)

Marks

- (d) The diagram below shows a light source, slits, and a translucent screen arranged for an experiment on light. Light and dark bands form on the screen. The light has a wavelength of 590 nm. The diagram is not to scale. 7

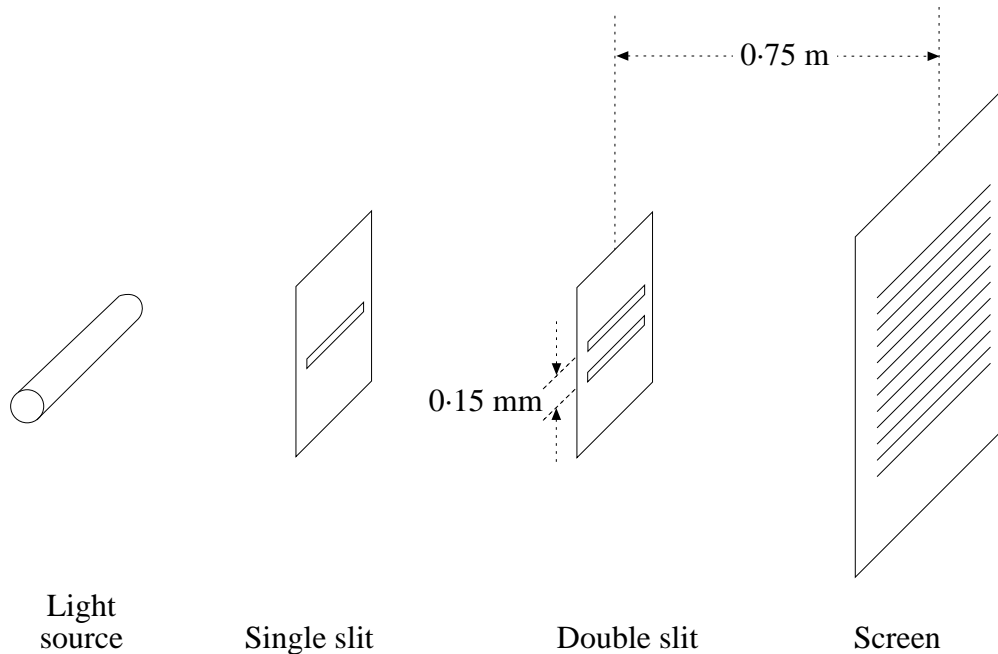

- (i) What is the function of the single slit in this experiment?
- (ii) What is the function of the double slit in this experiment?
- (iii) Explain how any one of the dark bands forms on the screen.
- (iv) The distance between the centres of the double slit is 0.15 mm, and the distance between the double slit and the screen is 0.75 m. Calculate the distance on the screen from the centre of the central maximum to the centre of a second-order bright band.
- (v) Describe what would happen to the distance calculated in part (iv) if the slit separation in the double slit were increased.

## QUESTION 33. (Continued)

Marks

- (e) (i) Light, with intensity  $I_0$ , passes through a sheet of Polaroid material that reduces the light intensity to  $0.5 I_0$ . The optical axis of the Polaroid material is vertical. 3

The light then passes through a second sheet of Polaroid material with its face parallel to that of the first.

At what angle should the optical axis of the second sheet (relative to the optical axis of the first sheet) be placed to reduce the intensity of the light to 30% of  $I_0$ ?

- (ii) People who fish prefer to wear polarising sunglasses because they say it helps them to see the fish below the surface of the water more clearly.

Describe the physical principle that could be used to support this belief.

- (iii) Light from the Sun is scattered at right angles towards an observer by particles in the air. Explain why the scattered light is plane polarised.

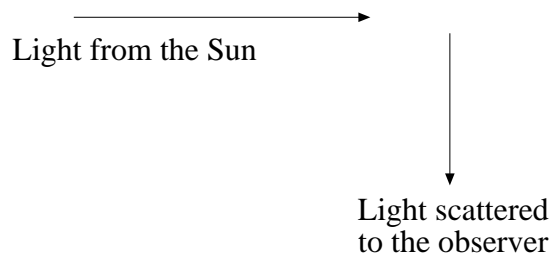

- (f) Spectral analysis of light from a galaxy allows astronomers to say that this light has been red-shifted. 4

- (i) Explain what the astronomers mean by the term 'red-shifted'.
- (ii) What conclusion can they draw from this observation?
- (iii) The relative speed of a light source and an observer along a line of sight is  $v$ . The speed of light is  $c$ . When  $v$  is small compared with  $c$ , the relationship between the emitted frequency,  $f_0$ , and the observed frequency,  $f$ , of the light is given by

$$f = \frac{f_0}{\left(1 \pm \frac{v}{c}\right)}$$

A star is travelling towards the Earth with a speed of 1.5% the speed of light. Light of wavelength  $7.0 \times 10^{-7}$  m is emitted by the star.

What is the frequency of this light when it reaches the Earth?

**QUESTION 34. Rotation** (25 marks)**Marks**

The information in this table may be needed to answer questions in this elective. Each object has a mass,  $M$ .

<i>Object</i>	<i>Axis</i>	<i>Moment of inertia</i>
Disc (radius, $R$ )	Through centre, perpendicular to plane of disc	$\frac{1}{2} MR^2$
Sphere (radius, $R$ )	Through centre	$\frac{2}{5} MR^2$
Thin rod (length, $L$ )	Through centre, perpendicular to the length of rod	$\frac{1}{12} ML^2$

- (a) A compact disc (CD) is uniformly accelerated from rest to an angular velocity of 200 r.p.m. in 1.5 seconds. **2**
- (i) Calculate the angular acceleration experienced by the CD.
  - (ii) Calculate the angle through which the CD moves during the 1.5 seconds.
- (b) Information about the Earth is given in the following table. **4**

Mass of the Earth	$5.98 \times 10^{24} \text{ kg}$
Radius of the Earth	$6.38 \times 10^6 \text{ m}$
Time for the Earth to move once around the Sun	$3.15 \times 10^7 \text{ s}$
Time for the Earth to move once about its axis	$8.64 \times 10^4 \text{ s}$

Assuming the Earth is a uniform, solid, sphere, calculate:

- (i) the angular velocity of the Earth about its axis;
- (ii) the linear speed of a point on the equator of the Earth as it rotates about its axis;
- (iii) the moment of inertia of the Earth about an axis through its centre;
- (iv) the angular momentum of the Earth about its own axis.

## QUESTION 34. (Continued)

Marks

- (c) A thin uniform rod of length 0.76 m and mass 0.65 kg is used as a pendulum for a large clock. It is suspended at a point 0.12 m from the top end as shown. 3

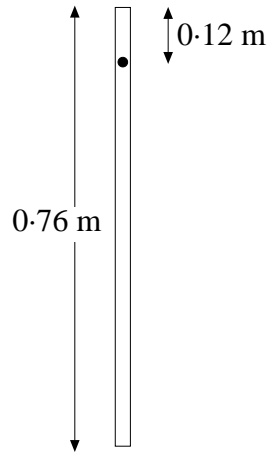

- (i) Determine the moment of inertia of the pendulum about a horizontal axis through the point of suspension.
- (ii) The diagram below shows the compound pendulum in a grandfather clock.

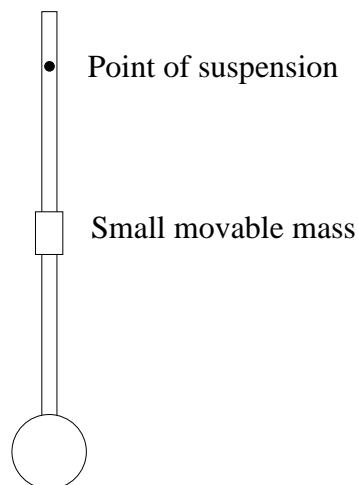

The period of a compound pendulum is given by

$$T = 2\pi \sqrt{\frac{I}{Mgd}}$$

- where  $I$  is the moment of inertia about the point of suspension;  
 $d$  is the distance between the point of suspension and the centre of gravity;  
 $M$  is the mass of the pendulum.

Explain, in terms of the physical principles involved, the function of the small movable mass.

## QUESTION 34. (Continued)

Marks

- (d) Three metre rules are rotated about different axes as shown in the diagrams below. 4

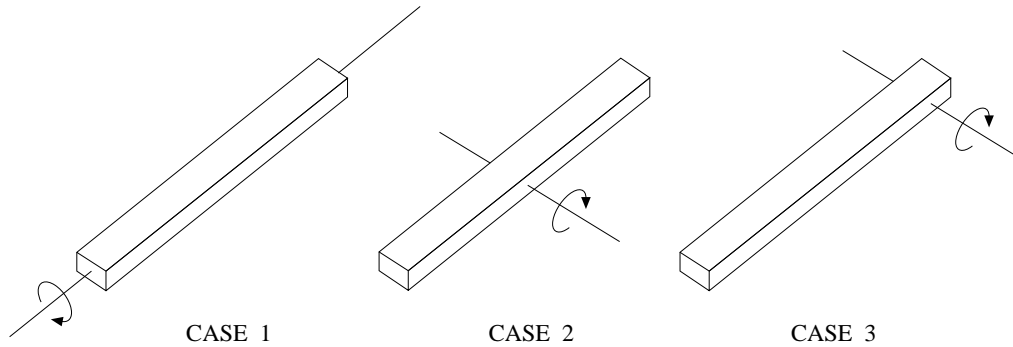

The moment of inertia is least for case 1, and greatest for case 3.

- (i) Explain why the moment of inertia in case 2 is greater than that in case 1.
  - (ii) Explain why the moment of inertia in case 3 is greater than that in case 2.
- (e) The following diagram represents a 3.2 kg steel ball being thrown. 3

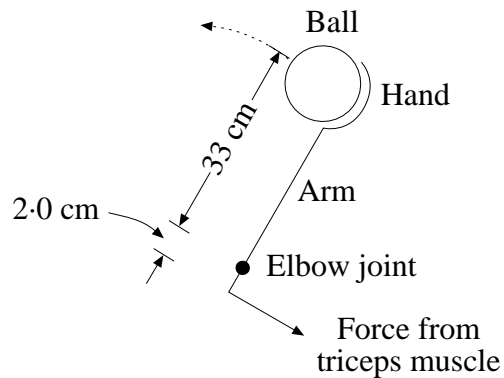

To simplify the problem, assume that the mass of the arm can be ignored and that the mass of the ball is concentrated at its centre.

While the ball is in the hand, its angular acceleration is  $17 \text{ rad s}^{-2}$ .

Calculate:

- (i) the moment of inertia of the ball about an axis perpendicular to the page through the elbow joint ;
- (ii) the torque required to produce the observed angular acceleration;
- (iii) the force that must be exerted by the triceps muscle in throwing the ball.



## QUESTION 34. (Continued)

Marks

- (f) After an explosion in a spacecraft, a rectangular sheet of metal with dimensions  $2.6 \text{ m} \times 1.8 \text{ m}$  moves through space with a velocity of  $32 \text{ m s}^{-1}$ . The mass of the sheet is  $44 \text{ kg}$ . 3

As it moves, it also rotates with an angular velocity of  $8.0 \text{ rad s}^{-1}$  about its short axis of symmetry as shown.

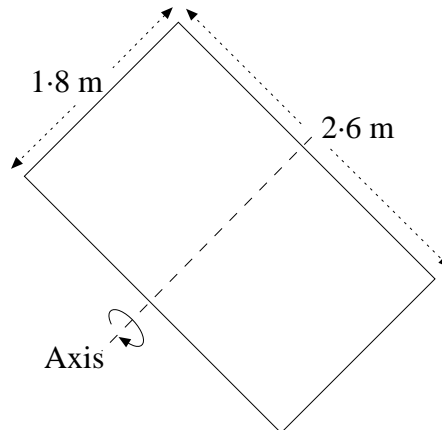

The moment of inertia about the short axis is  $25 \text{ kg m}^2$ .

Calculate the total kinetic energy of the sheet of metal.

- (g) A diver can increase her moment of inertia about an axis through her centre of gravity by a factor of  $3.8$  when changing from the tuck position to the straight position as shown below. 3

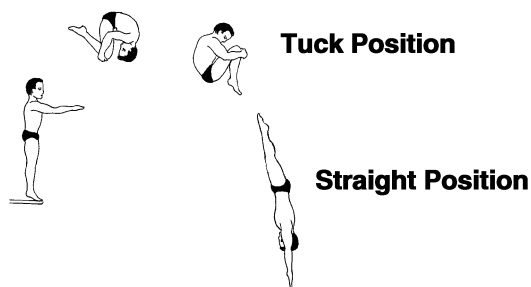

She makes one complete revolution in the tuck position in  $0.75$  seconds.

What is her angular velocity, in radians per second, when in the straight position?

- (h) With the aid of a diagram, explain what is meant by the term 'precession'. 3

**QUESTION 35. Physics in Technology** (25 marks)**Marks**

If you are attempting this elective, you must do TWO half-electives.

Answer each half-elective in a *separate* Elective Answer Book.

**A. Half-elective: Engineering Materials and Structures** ( $12\frac{1}{2}$  marks)

- (a) A cantilever,  $ABCD$ , is constructed of light, strong, separate members,  $AB$ ,  $BC$ ,  $CA$ , and  $BD$ , as shown in the diagram. It is used as part of a crane to lift a heavy load. The diagram is not to scale. **4**

Each joint is hinged. It is also hinged at the wall and supported by a rope attached to a point  $X$ ,  $5.07\text{ m}$  above the hinge. The angle between the rope and the wall is  $35^\circ$ .

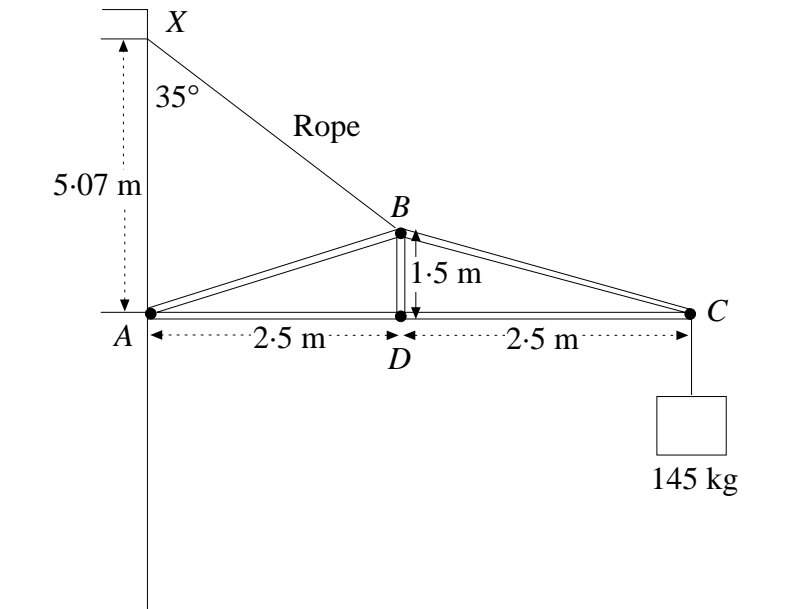

- (i) Sketch a vector diagram showing the directions of the forces acting at the point  $C$ . Label each force clearly.
- (ii) Calculate the tension in the rope  $XB$ .

## QUESTION 35. (Continued)

Marks

- (b) A block of metal is shaped as shown. The point  $X$  is the centre of the smaller end. The axis of the block passes through point  $X$  as shown. 2

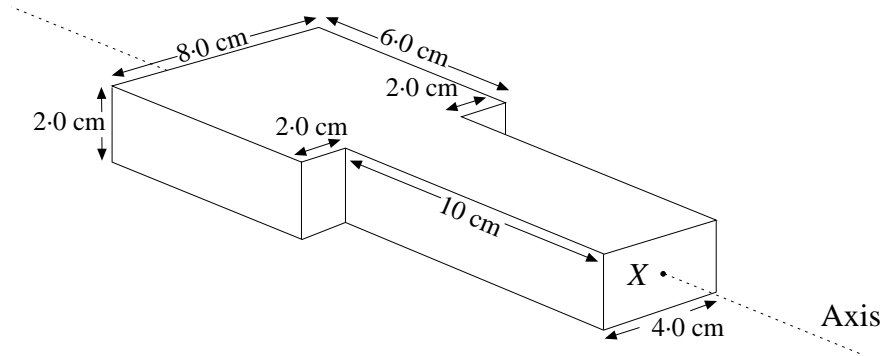

The centre of the mass of the block lies on the axis. Find the distance of the centre of mass from point  $X$ .

- (c) A wire cable is used to support a mass of 145 kg. 5½

Information about the cable is given in the following table.

<i>Property</i>	<i>Value</i>
Length	5.00 m
Diameter	1.50 cm
Young's modulus	$2.20 \times 10^{11} \text{ Nm}^{-2}$

Assume that the weight of the cable is negligible.

- (i) Calculate the stress in the cable.
  - (ii) Calculate the strain in the cable.
  - (iii) Calculate the extension, assuming that the elastic limit of the cable has not been reached.
  - (iv) The mass is now gradually increased until the cable breaks. Sketch a graph of the force on the cable versus the extension during this process.
- (d) A strut is to be designed with a given cross-sectional area and length. It must withstand a large compression force without buckling. Sketch the cross-section of the strut that would be expected to provide maximum resistance to buckling. 1

## QUESTION 35. (Continued)

Marks

Answer this half-elective in a *new* Elective Answer Book.

**B. Half-elective: Optical Instruments** ( $12\frac{1}{2}$  marks)

- (a) (i) Draw a clearly labelled diagram of a Cassegrain reflecting telescope, showing its main features. 4
- (ii) Describe ONE major difference between a Cassegrain and a Newtonian telescope.
- (iii) Why are the mirrors which are used in reflecting telescopes silvered on the front rather than on the back?
- (b) A refracting telescope uses lenses instead of mirrors. 3
- (i) Calculate the magnification of a refracting telescope which has an objective lens of focal length 60 cm and an eyepiece of focal length 2.5 cm.
- (ii) What is meant by 'chromatic aberration' in a lens?
- (iii) How can chromatic aberration be reduced in a refracting telescope?
- (c) A 2.0 cm object is positioned 4.0 cm to the left of a convex mirror as shown below.  $3\frac{1}{2}$

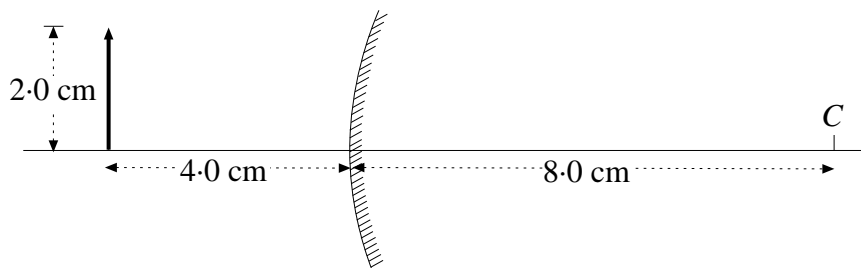

The centre of curvature of the mirror is 8.0 cm to the right of the mirror.

- (i) Carefully redraw the diagram in your Answer Book, and complete the ray diagram to show the position and size of the image formed.
- (ii) Fully describe the nature of the image formed by this mirror.
- (d) In prismatic binoculars, right-angle prisms are used to direct the light that enters the objective lens to the eyepiece. 2
- (i) Sketch one of these prisms, and show the path that one ray of light would take through it.
- (ii) What is ONE advantage of using prisms instead of mirrors in binoculars?

## QUESTION 35. (Continued)

Marks

Answer this half-elective in a *new* Elective Answer Book.

**C. Half-elective: Transformation of Energy** ( $12\frac{1}{2}$  marks)

- (a) In an experiment to determine the efficiency of a 240 V, 2000 W electric kettle, a student boiled water and recorded the following results. 4

Mass of water	1.2 kg
Initial temperature	25°C
Time taken to reach 100°C	3 minutes 30 seconds

- (i) Determine the amount of energy absorbed by the water.
- (ii) Determine the amount of electrical energy supplied by the kettle.
- (iii) Calculate the efficiency of the kettle.
- (iv) Account for the apparent loss of electrical energy.
- (b) A solar cell that tracks the sun produces an average of 45 W of electrical power per square metre of its surface area during a day. 2  $\frac{1}{2}$
- Assuming that the sun shines for twelve hours a day, how large an area would be required to supply 12 kWh per day?
- (c) A solar furnace concentrates energy from the sun to heat objects to temperatures in excess of 2000°C. 3
- (i) Describe how a solar furnace could be used to produce electricity.
- (ii) Name ONE major advantage of using a solar furnace for large-scale electricity production.

## QUESTION 35. (Continued)

**Marks**

- (d) (i) The fusion of two nuclei of deuterium ( ${}^2_1\text{H}$ ) to give one nucleus of helium ( ${}^3_2\text{He}$ ) may one day be used in nuclear power generation. The equation for this reaction is **3**

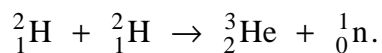

The mass of the deuterium nucleus is 2.01355 amu, while the mass of the helium nucleus is 3.01492 amu and the mass of a neutron is 1.00867 amu.

Determine the amount of energy released in each fusion reaction.

- (ii) At the present time, nuclear energy is produced commercially only by fission reactions.

Although more energy is produced in each fission reaction than in each fusion reaction, many people continue to consider fusion to be a better energy source for the future.

Give ONE reason why fusion might be a better source of energy than fission.

**QUESTION 36. Astronomy** (25 marks)**Marks**

- (a) (i) Draw a diagram to show how a distance of 1 parsec is defined. **6**
- (ii) Explain what is meant by the absolute magnitude of a star.
- (iii) A star has a colour index of +1.6. Explain what this tells us about the star.
- (iv) Light from stars reveals both emission spectra and absorption spectra. What information about a star is revealed by each type of spectrum?

- (b) The following table gives information about the star Achernar. **2**

<i>Property</i>	<i>Value</i>
Spectral type	B5
Apparent magnitude	+0.60
Parallax	0.049"

- (i) Calculate the absolute magnitude of Achernar.
- (ii) How far from the Earth is Achernar?
- (c) The star Delta Cephei is a Cepheid variable star whose apparent magnitude changes from 3.5 to 4.4 and back in about 5.5 days. **5**
- (i) Calculate the ratio,  $\frac{\text{greatest brightness}}{\text{least brightness}}$ , for Delta Cephei.
- (ii) Sketch a graph showing how the brightness of Delta Cephei changes over one cycle of 5.5 days.
- (iii) How are Cepheid variables used to measure their distance from the Earth?
- (d) An eclipsing binary consists of a large, hot star and a black dwarf with a period of twenty-five years. **2**

Sketch the light curve for this binary system over a seventy-five year period.

## QUESTION 36. (Continued)

Marks

- (e) (i) Draw and label the axes of a Hertzsprung–Russell diagram. 2
- (ii) Show, on the diagram, the position of the following stars:

<i>Star</i>	<i>Type of star</i>
Proxima Centauri	A red dwarf
Sirius A	An A0 main sequence star
Betelgeuse	A red super giant star

- (f) (i) What is the main difference between a star cluster and a constellation? 3
- (ii) What is ONE difference between an open cluster and a globular cluster?
- (iii) Why are star clusters useful in studying stellar evolution?
- (g) (i) Describe the process by which a star moves from the main sequence to become a red giant. 5
- (ii) What is the main property of a dust cloud which determines whether or not it will give rise to a future supernova?
- (iii) The carbon cycle (CNO cycle) is thought to be the source of energy for many large stars. The complete cycle is represented by the following set of nuclear reactions.

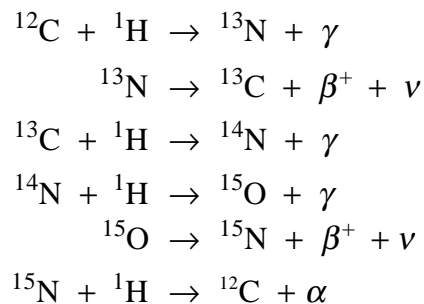

- List the product nuclei that remain after this cycle is completed.
- Apart from the production of energy, in what way is the CNO cycle similar to the proton–proton cycle in the Sun?



BLANK PAGE

BLANK PAGE

## PHYSICS DATA SHEET

*Values of several numerical constants*

Avogadro's constant, $N_A$	$6.022 \times 10^{23} \text{ mol}^{-1}$
Elementary charge, $e$	$1.602 \times 10^{-19} \text{ C}$
Faraday constant, $F$	$96\,490 \text{ C mol}^{-1}$
Gas constant, $R$	$8.314 \text{ J K}^{-1} \text{ mol}^{-1}$ $0.0821 \text{ L-atm K}^{-1} \text{ mol}^{-1}$
Mass of electron, $m_e$	$9.109 \times 10^{-31} \text{ kg}$
Mass of neutron, $m_n$	$1.675 \times 10^{-27} \text{ kg}$
Mass of proton, $m_p$	$1.673 \times 10^{-27} \text{ kg}$
Volume of 1 mole ideal gas at 101.3 kPa (1 atm) and at 0°C (273 K)	22.41 litre
at 25°C (298 K)	24.47 litre
Speed of sound in air	$340 \text{ m s}^{-1}$
Earth's gravitational acceleration, $g$	$9.8 \text{ m s}^{-2}$
Speed of light, $c$	$3.00 \times 10^8 \text{ m s}^{-1}$
Ampère's constant, $\left(\frac{\mu_0}{2\pi}\right)$	$2 \times 10^{-7} \text{ N s}^2 \text{ C}^{-2}$
Universal gravitation constant, $G$	$6.7 \times 10^{-11} \text{ N m}^2 \text{ kg}^{-2}$
Mass of Earth	$6.0 \times 10^{24} \text{ kg}$
Planck's constant, $h$	$6.626 \times 10^{-34} \text{ J s}$
Rydberg's constant, $R_H$	$1.097 \times 10^7 \text{ m}^{-1}$
Atomic mass unit, $u$	$1.661 \times 10^{-27} \text{ kg}$ $931.5 \text{ MeV}/c^2$
Density of water, $\rho$	$1.00 \times 10^3 \text{ kg m}^{-3}$
Specific heat capacity of water	$4.18 \times 10^3 \text{ J kg}^{-1} \text{ K}^{-1}$

# PERIODIC TABLE

1 H 1.008 Hydrogen
-----------------------------

2 He 4.003 Helium
----------------------------

### KEY

Atomic Number

79 Au 197.0 Gold
---------------------------

Symbol of element

Atomic Mass

Name of element

3 Li 6.941 Lithium	4 Be 9.012 Beryllium											5 B 10.81 Boron	6 C 12.01 Carbon	7 N 14.01 Nitrogen	8 O 16.00 Oxygen	9 F 19.00 Fluorine	10 Ne 20.18 Neon
11 Na 22.99 Sodium	12 Mg 24.31 Magnesium											13 Al 26.98 Aluminium	14 Si 28.09 Silicon	15 P 30.97 Phosphorus	16 S 32.07 Sulfur	17 Cl 35.45 Chlorine	18 Ar 39.95 Argon
19 K 39.10 Potassium	20 Ca 40.08 Calcium	21 Sc 44.96 Scandium	22 Ti 47.88 Titanium	23 V 50.94 Vanadium	24 Cr 52.00 Chromium	25 Mn 54.94 Manganese	26 Fe 55.85 Iron	27 Co 58.93 Cobalt	28 Ni 58.69 Nickel	29 Cu 63.55 Copper	30 Zn 65.39 Zinc	31 Ga 69.72 Gallium	32 Ge 72.59 Germanium	33 As 74.92 Arsenic	34 Se 78.96 Selenium	35 Br 79.90 Bromine	36 Kr 83.80 Krypton
37 Rb 85.47 Rubidium	38 Sr 87.62 Strontium	39 Y 88.91 Yttrium	40 Zr 91.22 Zirconium	41 Nb 92.91 Niobium	42 Mo 95.94 Molybdenum	43 Tc 98.91 Technetium	44 Ru 101.1 Ruthenium	45 Rh 102.9 Rhodium	46 Pd 106.4 Palladium	47 Ag 107.9 Silver	48 Cd 112.4 Cadmium	49 In 114.8 Indium	50 Sn 118.7 Tin	51 Sb 121.8 Antimony	52 Te 127.6 Tellurium	53 I 126.9 Iodine	54 Xe 131.3 Xenon
55 Cs 132.9 Cesium	56 Ba 137.3 Barium	57 La 138.9 Lanthanum	72 Hf 178.5 Hafnium	73 Ta 180.9 Tantalum	74 W 183.9 Tungsten	75 Re 186.2 Rhenium	76 Os 190.2 Osmium	77 Ir 192.2 Iridium	78 Pt 195.1 Platinum	79 Au 197.0 Gold	80 Hg 200.6 Mercury	81 Tl 204.4 Thallium	82 Pb 207.2 Lead	83 Bi 209.0 Bismuth	84 Po — Polonium	85 At — Astatine	86 Rn — Radon
87 Fr — Francium	88 Ra 226.0 Radium	89 Ac — Actinium	104	105	106												

58 Ce 140.1 Cerium	59 Pr 140.9 Praseodymium	60 Nd 144.2 Neodymium	61 Pm — Promethium	62 Sm 150.4 Samarium	63 Eu 152.0 Europium	64 Gd 157.3 Gadolinium	65 Tb 158.9 Terbium	66 Dy 162.5 Dysprosium	67 Ho 164.9 Holmium	68 Er 167.3 Erbium	69 Tm 168.9 Thulium	70 Yb 173.0 Ytterbium	71 Lu 175.0 Lutetium
90 Th 232.0 Thorium	91 Pa 231.0 Protactinium	92 U 238.0 Uranium	93 Np 237.0 Neptunium	94 Pu — Plutonium	95 Am — Americium	96 Cm — Curium	97 Bk — Berkelium	98 Cf — Californium	99 Es — Einsteinium	100 Fm — Fermium	101 Md — Mendelevium	102 No — Nobelium	103 Lr — Lawrencium

.....

This sheet should be REMOVED for your convenience.