



**B O A R D O F S T U D I E S**  
NEW SOUTH WALES

**2003**

**HIGHER SCHOOL CERTIFICATE  
EXAMINATION**

# Metal and Engineering

## General Instructions

- Reading time – 5 minutes
- Working time – 2 hours
- Write using black or blue pen
- Board-approved calculators may be used
- Write your Centre Number and Student Number at the top of page 9

**Total marks – 80**

**Section I** Pages 2–7

**15 marks**

- Attempt Questions 1–15
- Allow about 15 minutes for this section

**Section II** Pages 9–18

**35 marks**

- Attempt Questions 16–20
- Allow about 45 minutes for this section

**Section III** Pages 19–21

**30 marks**

- Attempt TWO questions from Questions 21–23
- Allow about 1 hour for this section

## Section I

15 marks

Attempt Questions 1–15

Allow about 15 minutes for this section

Use the multiple-choice answer sheet.

Select the alternative A, B, C or D that best answers the question. Fill in the response oval completely.

**Sample:**  $2 + 4 =$  (A) 2 (B) 6 (C) 8 (D) 9  
A  B  C  D

If you think you have made a mistake, put a cross through the incorrect answer and fill in the new answer.

A  B  C  D

If you change your mind and have crossed out what you consider to be the correct answer, then indicate the correct answer by writing the word **correct** and drawing an arrow as follows.

A  B  C  D   
*correct* ↙

---

1 Name the power tool shown below.

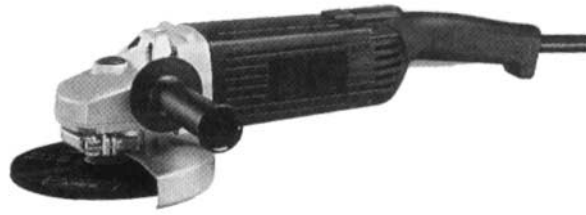

- (A) Angle grinder
- (B) Bench grinder
- (C) Cut-off grinder
- (D) Straight grinder

2 What tool should be used to cut a slot into a 1 mm thick mild steel sheet?

- (A) Grinder
- (B) Guillotine
- (C) Nibbler
- (D) Tin snips

3 What tool would be used to tighten the screw shown below?

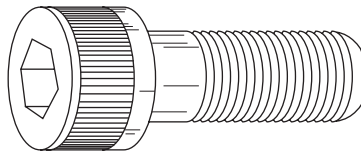

Reproduced with the permission of TAFE NSW, Manufacturing and Engineering Division.

- (A) Allen key
- (B) Screw key
- (C) Socket drive
- (D) Spline drive

4 A hand-held hacksaw is to be used to cut 2 mm thick mild steel sheet.

What hacksaw blade would be the most appropriate for this task?

- (A) 18 teeth per 25 mm (1 inch)
- (B) 24 teeth per 25 mm (1 inch)
- (C) 32 teeth per 25 mm (1 inch)
- (D) 48 teeth per 25 mm (1 inch)

5 Which of the following is the most appropriate tool to tighten a non-standard hexagonal nut?

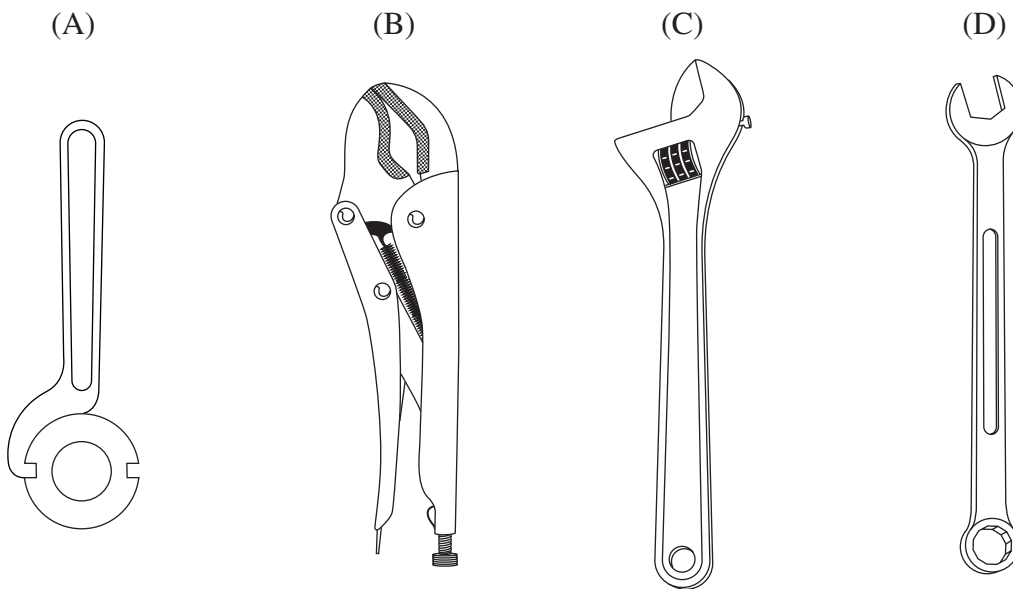

6 Name the measuring device shown.

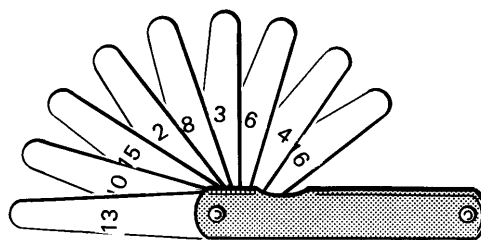

- (A) Thermometer
- (B) Feeler gauge
- (C) Caliper
- (D) Screw gauge

- 7 A client in a metal machine shop complains to the owner that there are waste bins blocking an emergency exit.

Who has responsibility for ensuring that the exit is clear?

- (A) The client
  - (B) The owner
  - (C) The WorkCover representative
  - (D) The Occupational Health and Safety officer
- 8 An employer's 'duty of care', within a workplace, applies to which of the following groups of people?
- (A) Employees
  - (B) Employees and contractors
  - (C) Employers and contractors
  - (D) Anybody entering the workplace
- 9 The owner of a metal fabrication workshop has installed exhaust fans to extract fumes from the welding bays.

What type of hazard will this action reduce?

- (A) Biological
  - (B) Chemical
  - (C) Mechanical
  - (D) Psychological
- 10 According to Occupational Health and Safety (OHS) legislation, which of the following complies with the requirements for an OHS workplace committee?
- (A) One union representative, one WorkCover representative and two employer association representatives
  - (B) One union representative, one WorkCover representative and two representatives from management
  - (C) Three elected employee representatives and four employer-appointed representatives
  - (D) Four elected employee representatives and three employer-appointed representatives

Refer to the following information to answer Questions 11–13.

A metal fabrication company manufactures grates for fireplaces using  $40 \times 10$  mm mild steel.

A drawing of the grate is shown.

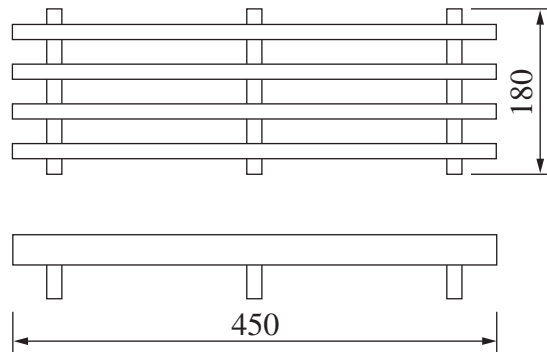

- 11** What is the minimum length of material required to manufacture a single grate?
- (A) 630 mm
  - (B) 1800 mm
  - (C) 2250 mm
  - (D) 2340 mm
- 12** It takes one person 90 seconds to cut the seven pieces of mild steel to length.
- How long would it take to cut the metal required for 12 grates?
- (A) 18 minutes
  - (B) 108 minutes
  - (C) 108 seconds
  - (D) 1800 seconds
- 13** A welder takes 90 seconds to weld the pieces of mild steel together to make one grate.
- What would be the total time required for three welders to assemble 36 grates?
- (A) 2700 seconds
  - (B) 3240 seconds
  - (C) 18 minutes
  - (D) 270 minutes

14 The false jaw shown below is to be made from mild steel.

What is the minimum length of material required?

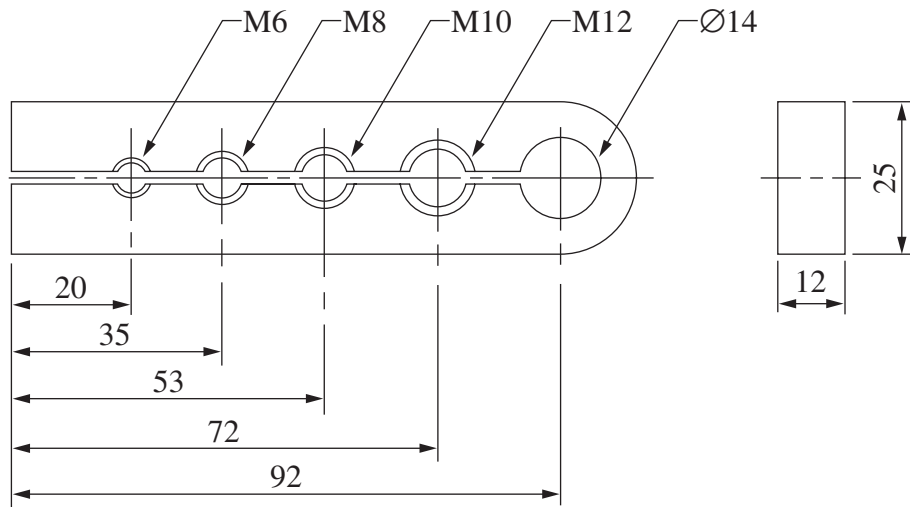

- (A) 92 mm
- (B) 99 mm
- (C) 105 mm
- (D) 117 mm

15 What is the special feature of the nut illustrated below?

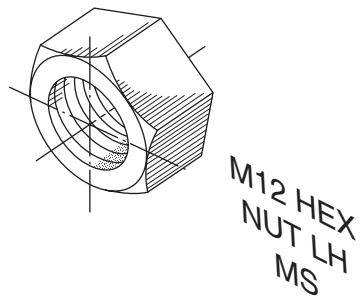

- (A) M12
- (B) MS
- (C) HEX
- (D) LH

BLANK PAGE



# Metal and Engineering

|  |  |  |  |  |
|--|--|--|--|--|
|  |  |  |  |  |
|--|--|--|--|--|

Centre Number

## Section II

|  |  |  |  |  |  |  |  |  |
|--|--|--|--|--|--|--|--|--|
|  |  |  |  |  |  |  |  |  |
|--|--|--|--|--|--|--|--|--|

Student Number

35 marks

Attempt Questions 16–20

Allow about 45 minutes for this section

Answer the questions in the spaces provided.

---

**Question 16** (7 marks)

**Please turn over**

**Question 16** (7 marks)

Figure 1 shows a graduated measuring device.

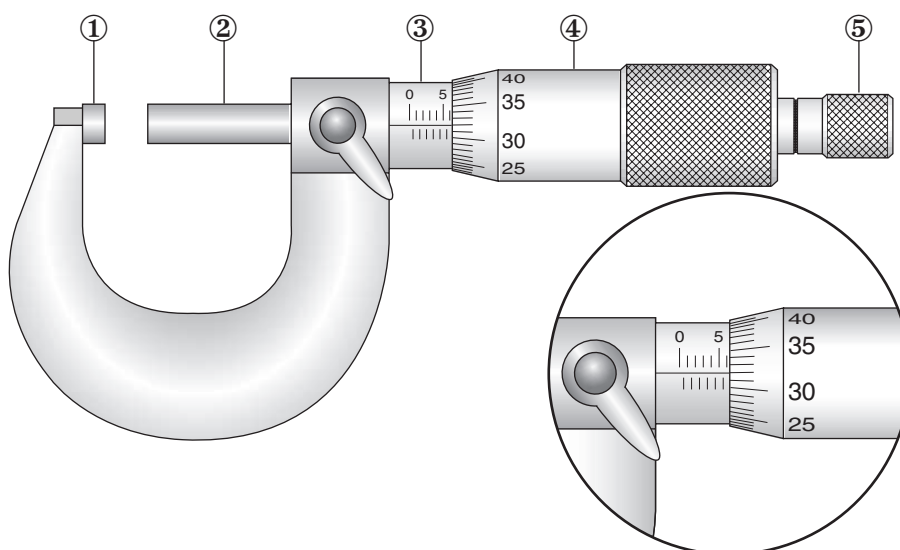

Figure 1

- (a) What is the name of the graduated measuring device shown in Figure 1? **1**  
 .....
- (b) To what degree of accuracy can this graduated measuring device measure? **1**  
 .....
- (c) What is the reading on the graduated measuring device shown in Figure 1? **2**  
 .....
- (d) Complete the table below by naming parts ①, ② and ③ as indicated on Figure 1. **3**

| <i>Item</i> | <i>Name</i> |
|-------------|-------------|
| ①           |             |
| ②           |             |
| ③           |             |
| ④           | Thimble     |
| ⑤           | Ratchet     |

Please detach pages 17 and 18 and refer to Drawing 2003–1, Sheet 1 of 2 on page 17 to answer Question 17.

**Question 17** (3 marks)

(a) What type of drawing is shown? **1**

.....

(b) How many items are shown? **1**

.....

(c) How many parts are required to assemble the trammel? **1**

.....

**Please turn over**

Refer to Drawing 2003–1, Sheet 2 of 2 on page 18 to answer Question 18.

**Question 18** (9 marks)

- (a) The scale on this drawing is shown as ‘NTS’. What does NTS mean? **1**  
.....
- (b) What drawing standard is used for this drawing? **1**  
.....  
.....
- (c) What type of drawing is shown? **1**  
.....
- (d) Refer to zone B1. The NUT, Item 3, has light lines at 45 degrees across it. What are these lines called? **1**  
.....

**Question 18 continues on page 13**

Question 18 (continued)

- (e) Refer to zone B6. The ADJUSTING NUT, Item 7, has a  $0.75 \times 45^\circ$  chamfer. **1**  
Indicate on Figure 2 where the dimension 0.75 is measured. Circle either option A or option B.

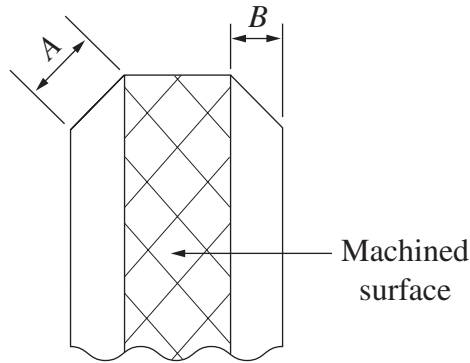

Figure 2

- (f) The ADJUSTING NUT, Item 7, has a machined surface on its outside diameter. **1**  
What is the purpose of this type of surface?

.....  
.....

- (g) The BEAM, Item 1, is drawn as two pieces. Why is it drawn this way? **3**

.....  
.....  
.....  
.....  
.....

**End of Question 18**

Refer to Drawing 2003–1, Sheet 2 of 2 on page 18 to answer Question 19.

**Question 19** (6 marks)

Refer to the ADJUSTING NUT, Item 7, and the ADJUSTING BLOCK, Item 8.

(a) Complete the tables below.

|     |  |               |          |
|-----|--|---------------|----------|
| (i) | The width of the ADJUSTING NUT, Item 7     | $4.7 \pm 0.1$ | <b>1</b> |
|     | Maximum width of the ADJUSTING NUT, Item 7 | 4.8           |          |
|     | Minimum width of the ADJUSTING NUT, Item 7 |               |          |

|      |  |               |          |
|------|--|---------------|----------|
| (ii) | The width of the slot in ADJUSTING BLOCK, Item 8     | $5.0 \pm 0.1$ | <b>2</b> |
|      | Maximum width of the slot in ADJUSTING BLOCK, Item 8 |               |          |
|      | Minimum width of the slot in ADJUSTING BLOCK, Item 8 |               |          |

(b) Calculate the maximum clearance between the ADJUSTING NUT, Item 7, and the slot in the ADJUSTING BLOCK, Item 8, when assembled. Show all working. **2**

.....

.....

.....

.....

(c) Name the precision measuring device that would be used to measure the clearance between the ADJUSTING NUT and the ADJUSTING BLOCK when assembled. **1**

.....

.....

Refer to Drawing 2003–1, Sheet 2 of 2 on page 18 to answer Question 20.

**Question 20** (10 marks)

- (a) The ADJUSTING NUT, Item 7, has an  $M3 \times 0.5$  thread. **3**

Calculate the drill size for this thread. Show all working.

.....  
.....  
.....

- (b) The ADJUSTING NUT, Item 7, has to screw onto the ADJUSTING SCREW, Item 9. Which item should be manufactured first? Justify your answer. **3**

.....  
.....  
.....  
.....  
.....

- (c) Outline the sequence of steps to produce the ADJUSTING SCREW, Item 9. **4**

.....  
.....  
.....  
.....  
.....  
.....  
.....  
.....  
.....  
.....  
.....  
.....  
.....  
.....  
.....  
.....  
.....  
.....  
.....  
.....  
.....

BLANK PAGE



Please detach this page and use Drawing 2003-1, Sheet 1 of 2 to answer Question 17.

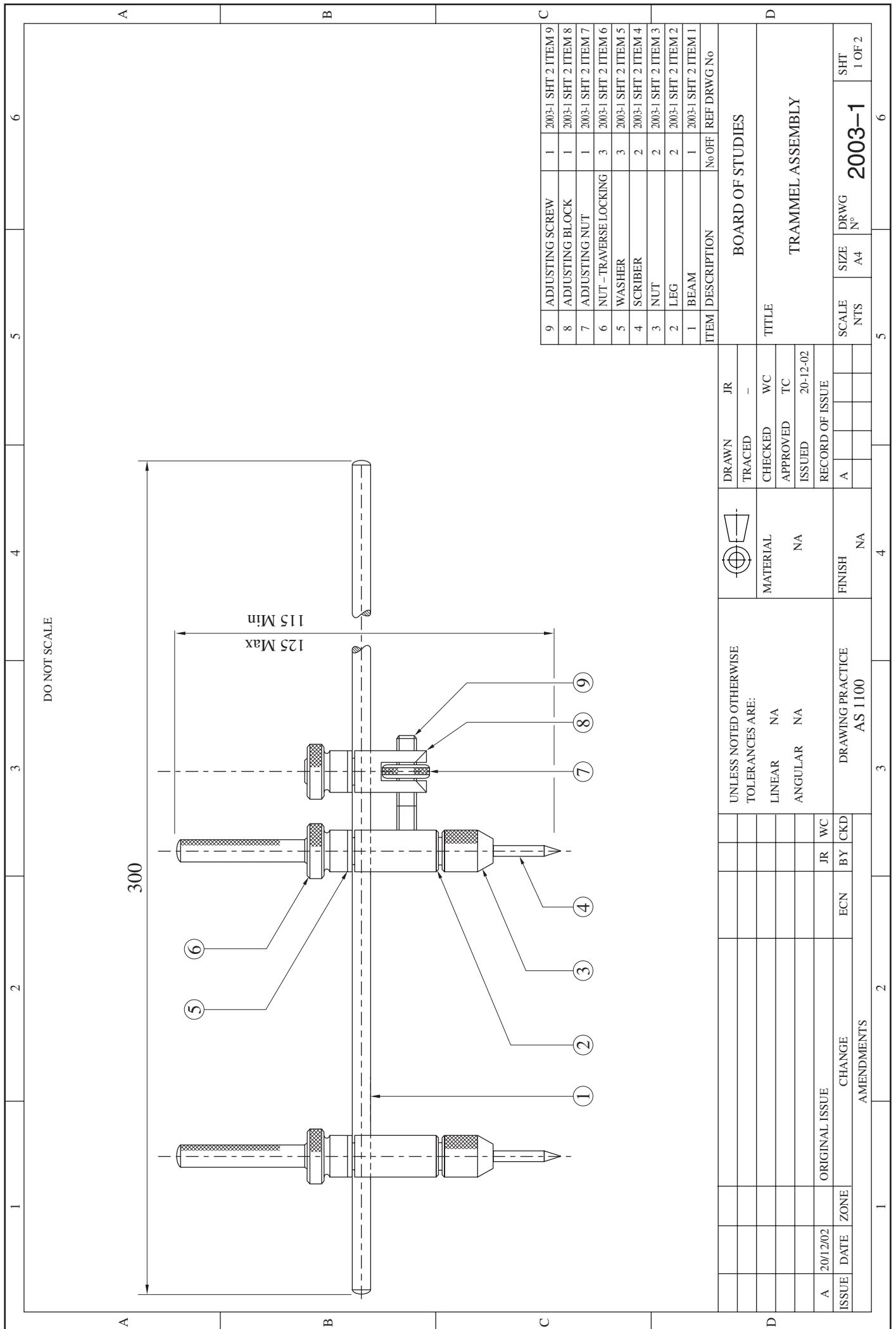

Please detach this page and use Drawing 2003-1, Sheet 2 of 2 to answer Questions 18, 19 and 20.

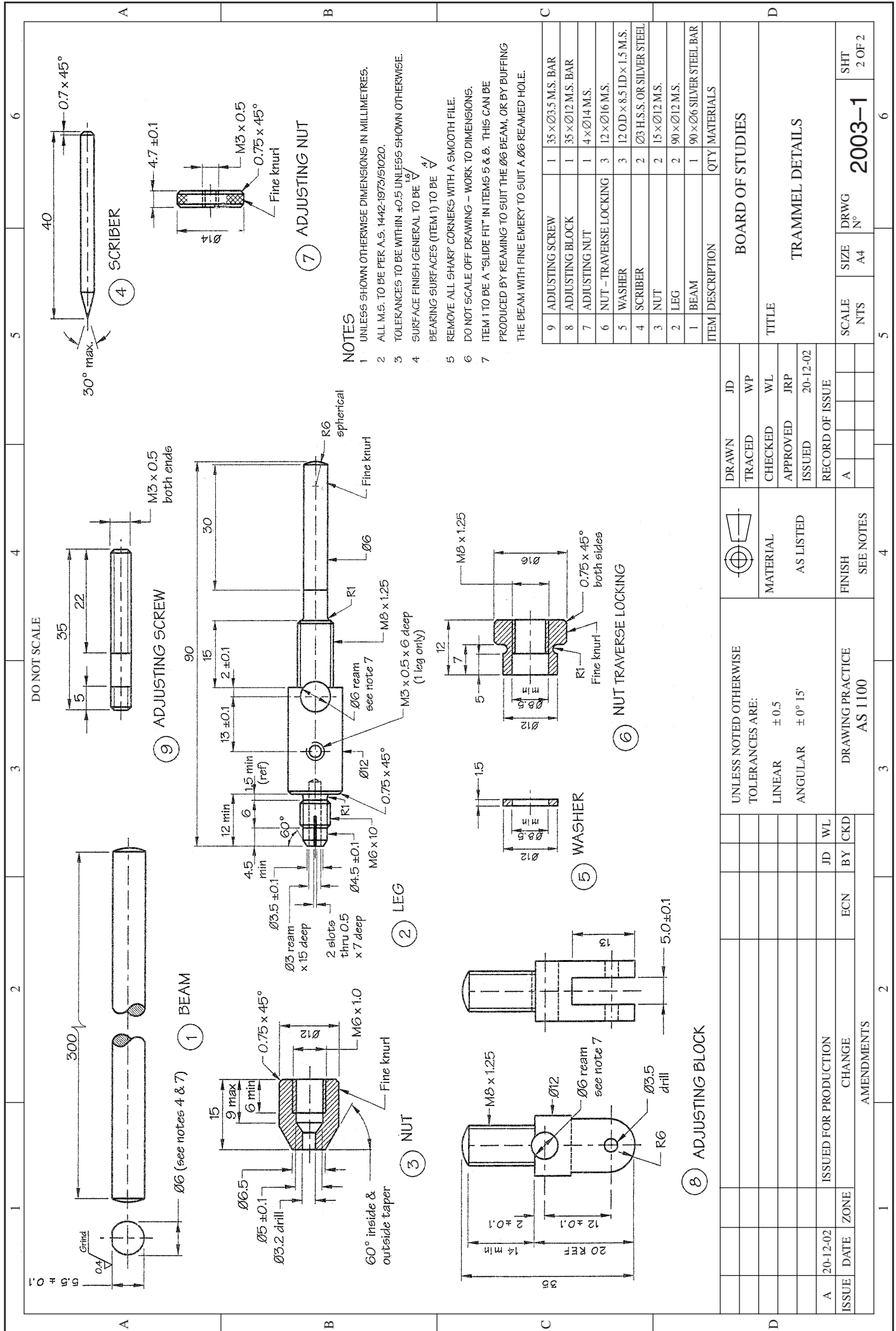

**NOTES**

- UNLESS SHOWN OTHERWISE DIMENSIONS IN MILLIMETRES.
- ALL M.S. TO BE PER A.S. 1442-1973/5/1020.
- TOLERANCES TO BE WITHIN ±0.5 UNLESS SHOWN OTHERWISE.
- SURFACE FINISH GENERAL TO BE  $\sqrt{1.6}$ .
- BEARING SURFACES (ITEM 1) TO BE  $\sqrt{4}$ .
- REMOVE ALL SHARP CORNERS WITH A SMOOTH FILE.
- DO NOT SCALE OFF DRAWING - WORK TO DIMENSIONS.
- ITEM 1 TO BE A "SLIDE FIT" IN ITEMS 5 & 8. THIS CAN BE PRODUCED BY REAMING TO SUIT THE Ø6 BEAM, OR BY BUFFING THE BEAM WITH FINE EMERY TO SUIT A Ø6 REAMED HOLE.

| ITEM | DESCRIPTION            | QTY | MATERIALS                     |
|------|------------------------|-----|-------------------------------|
| 9    | ADJUSTING SCREW        | 1   | 35 x Ø3.5 M.S. BAR            |
| 8    | ADJUSTING BLOCK        | 1   | 35 x Ø12 M.S. BAR             |
| 7    | ADJUSTING NUT          | 1   | 4 x Ø14 M.S.                  |
| 6    | NUT - TRAVERSE LOCKING | 3   | 12 x Ø16 M.S.                 |
| 5    | WASHER                 | 3   | 12 O.D. x 8.5 I.D. x 1.5 M.S. |
| 4    | SCRIBER                | 2   | Ø3 H.S.S. OR SILVER STEEL     |
| 3    | NUT                    | 2   | 15 x Ø12 M.S.                 |
| 2    | LEG                    | 2   | 90 x Ø6 SILVER STEEL BAR      |
| 1    | BEAM                   | 1   | 90 x Ø6 SILVER STEEL BAR      |

| BOARD OF STUDIES |       | TRAMMEL DETAILS |        |
|------------------|-------|-----------------|--------|
| TITLE            | SCALE | SIZE            | DRWG   |
|                  | NTS   | A4              | N°     |
|                  |       |                 | 2003-1 |
|                  |       |                 | SHT    |
|                  |       |                 | 2 OF 2 |

| UNLESS NOTED OTHERWISE TOLERANCES ARE: |          | DRAWING PRACTICE AS 1100 |           |
|--|----------|--------------------------|-----------|
| LINEAR                                 | ± 0.5    | FINISH                   | SEE NOTES |
| ANGULAR                                | ± 0° 15' |                          |           |
| MATERIAL AS LISTED                     |          | APPROVED                 | JRP       |
| AS LISTED                              |          | ISSUED                   | 20-12-02  |
| RECORD OF ISSUE                        |          |                          |           |
| A                                      | 20-12-02 | ISSUED FOR PRODUCTION    | JD        |
|  |          | CHANGE                   | BY        |
|  |          | AMENDMENTS               | CKD       |
|  |          | ECN                      | WL        |
|  |          | ZONE                     |           |
|  |          | DATE                     |           |

## Metal and Engineering

### Section III

**30 marks**

**Attempt TWO questions from Questions 21–23**

**Allow about 1 hour for this section**

Answer each question in a SEPARATE writing booklet. Extra writing booklets are available.

---

In your answers you will be assessed on how well you:

- demonstrate relevant knowledge and understanding
  - communicate ideas and information, using precise industry terminology and appropriate workplace examples
  - organise information in a well-reasoned and cohesive response
  - solve proposed issues or problems
- 

#### **Question 21** (15 marks)

An induction program for new employees in a metal and engineering workplace would include workplace standards for behaviour and personal presentation, communications and safety.

Analyse the benefits of an industry induction program.

#### **Question 22** (15 marks)

Occupational Health and Safety (OHS) legislation aims to maximise workplace safety.

Propose procedures an employer should implement to discuss workplace safety with employees.

**Please turn over**

---

In your answers you will be assessed on how well you:

- demonstrate relevant knowledge and understanding
  - communicate ideas and information, using precise industry terminology and appropriate workplace examples
  - organise information in a well-reasoned and cohesive response
  - solve proposed issues or problems
- 

**Question 23** (15 marks)

Refer to Drawing 2003–2 on page 21 to answer Question 23.

A ‘G CLAMP’ is to be manufactured. All items of the ‘G CLAMP’ have been machined except the CLAMP JAW, Item 1 (no drilled/tapped hole).

Plan a series of steps to complete the CLAMP JAW and the assembly of the CLAMP. Include ongoing and final checking procedures to ensure that the ‘G CLAMP’ operates correctly when assembled.

Use Drawing 2003-2 to answer Question 23.

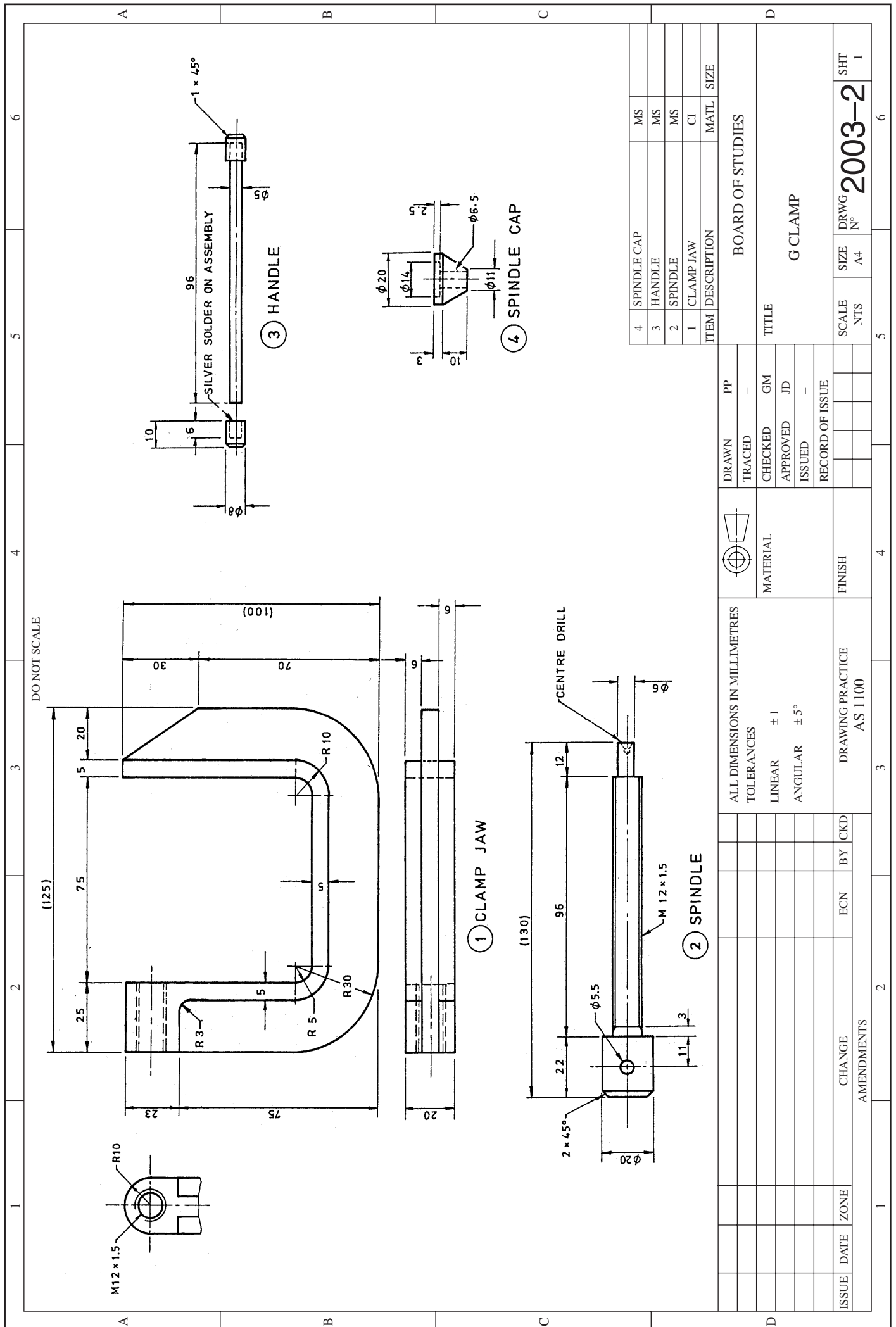

**End of paper**