



B O A R D O F S T U D I E S
NEW SOUTH WALES

2004

HIGHER SCHOOL CERTIFICATE
EXAMINATION

Information Processes and Technology

General Instructions

- Reading time – 5 minutes
- Working time – 3 hours
- Write using black or blue pen
- Draw diagrams using pencil

Total marks – 100

Section I Pages 2–12

20 marks

- Attempt Questions 1–20
- Allow about 40 minutes for this section

Section II Pages 13–16

40 marks

- Attempt Questions 21–24
- Allow about 1 hour and 10 minutes for this section

Section III Pages 17–20

40 marks

- Attempt TWO questions from Questions 25–28
- Allow about 1 hour and 10 minutes for this section

Section I

20 marks

Attempt Questions 1–20

Allow about 40 minutes for this section

Use the multiple-choice answer sheet.

Select the alternative A, B, C or D that best answers the question. Fill in the response oval completely.

Sample: $2 + 4 =$ (A) 2 (B) 6 (C) 8 (D) 9
A B C D

If you think you have made a mistake, put a cross through the incorrect answer and fill in the new answer.

A B C D

If you change your mind and have crossed out what you consider to be the correct answer, then indicate the correct answer by writing the word *correct* and drawing an arrow as follows.

A B C D
correct ↙

- 1 Which of the following is most relevant when writing an operation manual for a new information system?
- (A) Data flow diagram
 - (B) Technical feasibility
 - (C) Cost-benefit analysis
 - (D) Participants' background

- 2 The text below has been found in a file.

```
<title>Information Processes and Technology</title>
<p>Notes may be downloaded here
<a href="admin/IPTnotes.pdf"> IPT Notes </a> </p>
<p>&nbsp; </p>
<h3>Topics</h3>
```

Which of the following best describes the content of the file?

- (A) HTML code
 - (B) Programming code
 - (C) Rich text for a word processor
 - (D) Plain text for a word processor
- 3 A message is protected during transmission by applying an algorithm to the data. Another algorithm is applied to restore the original message after it is transmitted.

In order, what terms are given to these two processes?

- (A) Encoding and coding
- (B) Decryption and decoding
- (C) Decryption and encryption
- (D) Encryption and decryption

4 Which diagram represents the transmission of a digital signal?

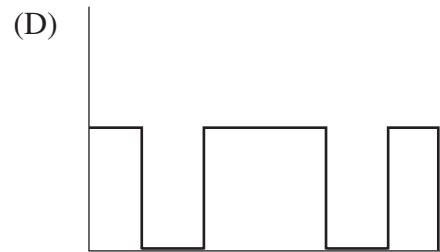
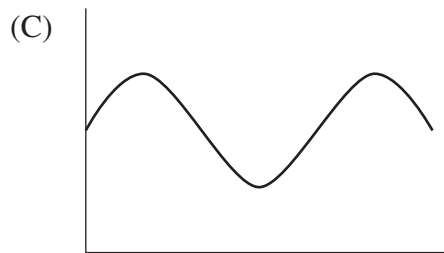
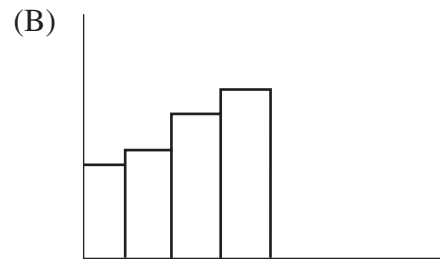
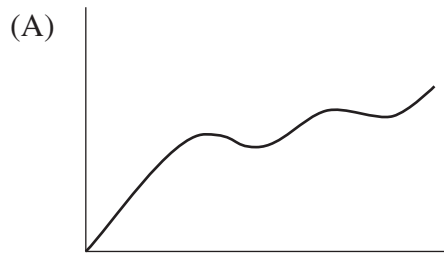



5 Which document typically assists in determining whether a project should proceed, based on an analysis of the benefits, costs and risks associated with the project?

- (A) Project plan
- (B) Feasibility study report
- (C) Project evaluation report
- (D) Asset management report

6 A bank customer makes a cash withdrawal using an automatic teller machine (ATM). What is the role of the customer in relation to the information system of the bank?

- (A) User only
- (B) Participant only
- (C) User and participant
- (D) User interface and participant

7 Use this information to answer Question 7.

Folder: INBOX				
	Date	From	Subject	Size
	20/11/2003	Rita Fox	Photos	640 Kb
	19/11/2003	Robert Haze	Committee meeting	1.6 Kb
	18/11/2003	Best Bargains	[SPAM***] Unbeatable offer . . .	1.2 Mb

What is the most likely reason [SPAM***] has been placed in the subject of the email from Best Bargains?

- (A) The email is the oldest.
- (B) The email contains a virus.
- (C) The email is considered to be too large.
- (D) The email is considered to be junk mail.

8 Jean investigates the use of a personal information system to produce party invitations. She is uncertain if she has the software on her computer to produce the invitations. She has only one week to complete the task.

What feasibilities apply to Jean's situation?

- (A) Economic and ethical
- (B) Technical and schedule
- (C) Operational and technical
- (D) Schedule and organisational

9 In contrast to older telephone technologies, new mobile-telephone technologies allow transmission of video and images in addition to voice. What is a feature of new mobile telephones that allows this capability?

- (A) They are smaller and more compact, allowing greater efficiency in transmission.
- (B) They have colour screens, providing a better interface for users for video and images.
- (C) They use a higher frequency, allowing transmission of more data which is needed for video and images.
- (D) Their networks place base-stations further apart, resulting in gains in transmission times, and hence transmission of more data.

Use this information to answer Questions 10–11.

A newsagency keeps product data in this database table.

Product

Product_ID	Product_Name	Price
1002	Disk case	8.99
1004	Mouse holder	12.50
1005	Mouse mat	6.58

After running a query, these data were extracted.

Product_Name
Disk case
Mouse mat

10 Which query below will generate these results?

- (A) SELECT Product_Name FROM Product WHERE Price > 9;
- (B) SELECT Product_Name FROM Product WHERE Price < 9;
- (C) SELECT Product_Name, Price FROM Product WHERE Price < 9;
- (D) SELECT Product_Name, Price FROM Product WHERE Price > 9;

11 The newsagency owner wishes to keep track of the large number of orders from customers. A customer may order the same product many times. The customer details are stored in a Customer table with Customer_ID as the primary key.

What is the most efficient way to organise the data and reduce data redundancy?

- (A) Store all data in the Product table or in the Customer table.
- (B) Create an Order table where Product_ID and Customer_ID are foreign keys.
- (C) Create an Order table where Product_ID and Customer_ID are primary keys.
- (D) Insert a Product_ID field into the Customer table and a Customer_ID field into the Product table.

12 The screen below displays a list of items retrieved using a web browser.

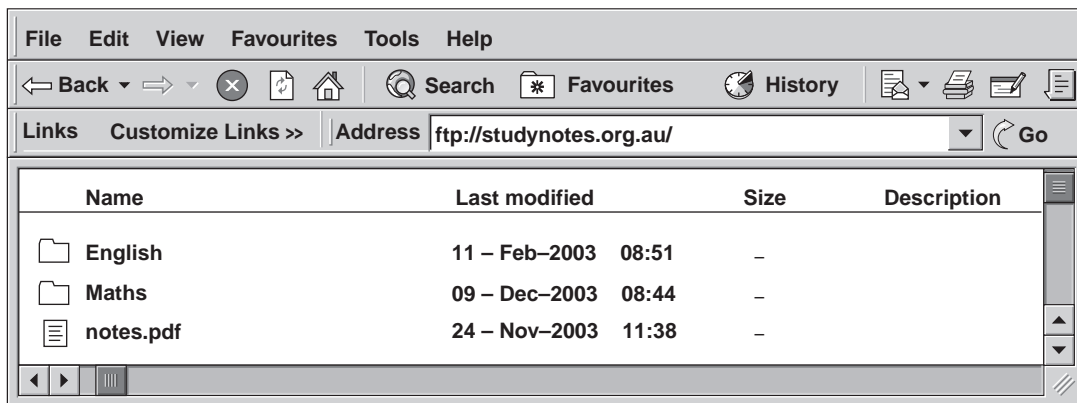

Which protocol has been used to retrieve the list of items?

- (A) File Transfer Protocol
- (B) Portable Document Format
- (C) Hypertext Transfer Protocol
- (D) Systems Network Architecture

13 Which of the following is NOT suitable for validating data?

- (A) Using a data mask to ensure that data entered has the correct format
- (B) Using features that check that data is in an acceptable range of values
- (C) Adding a data entry area on the screen to limit how much data users can see
- (D) Using pull-down menus for data entry to limit values that can be entered into the database

- 14 A fun park charges different entry fees for the categories of Child, Concession and Adult. This decision tree shows the criteria for the different categories.

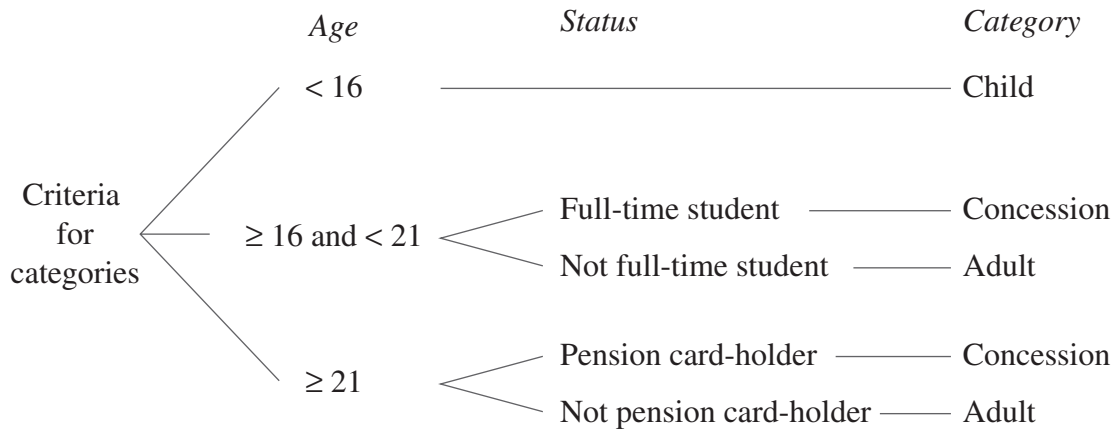

Use the information provided in the decision tree to determine the categories for these three people seeking entry.

- I** 55-year-old pension card-holder
- II** 21-year-old full-time student
- III** 15-year-old student

	I	II	III
(A)	Concession	Concession	Concession
(B)	Adult	Concession	Concession
(C)	Concession	Adult	Child
(D)	Adult	Adult	Child

15 Use this information to answer Question 15.

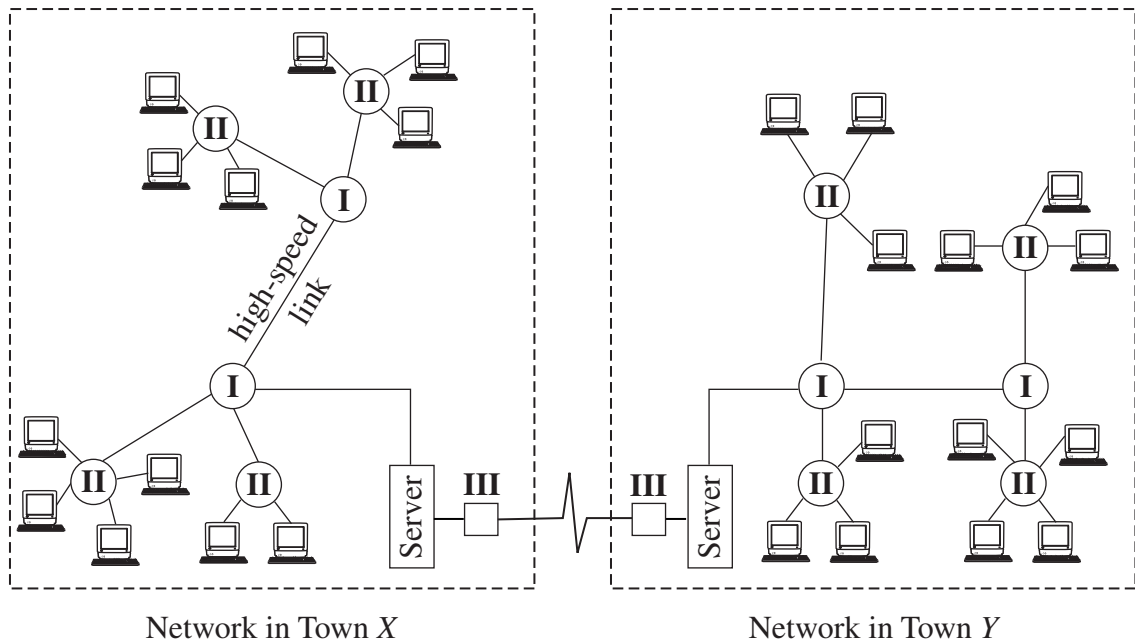

What devices should be placed at locations **I**, **II** and **III** to most effectively connect the two networks and the network components?

	I	II	III
(A)	switch	hub	router
(B)	switch	bridge	hub
(C)	hub	gateway	router
(D)	gateway	bridge	hub

- 16 An online bookstore's sales information system allows customers to search for books by entering an author's name. A list of books written by the author is then displayed. To purchase books, the customer needs only to indicate the desired books, and the amount payable will be displayed for the customer to pay by credit card.

The credit card details are validated with the relevant financial institution electronically. An email is generated for the customer and a transaction record is written to the sales transaction file.

Which of the system flowcharts below correctly represents the procedure for purchasing books?

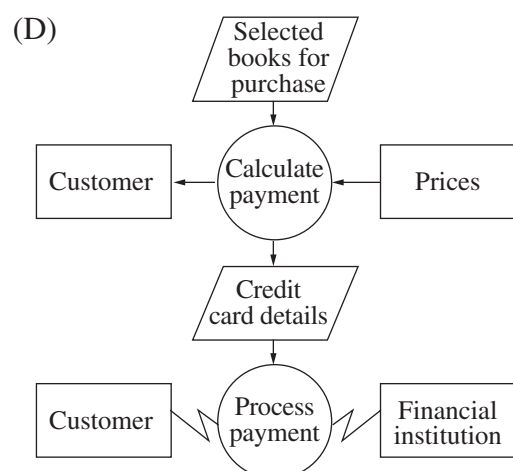
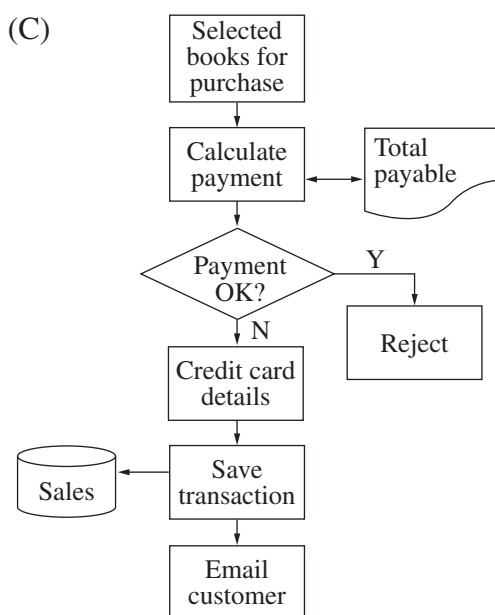
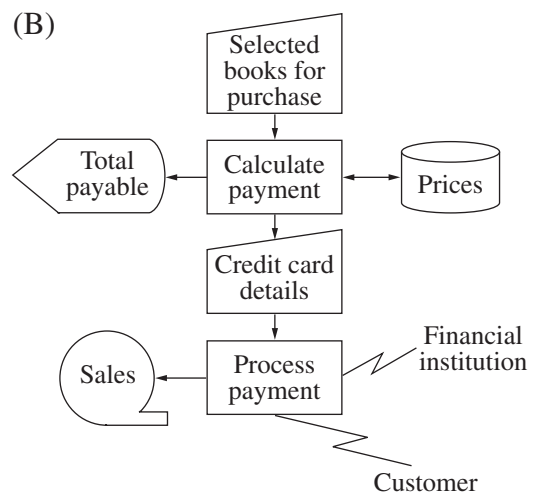
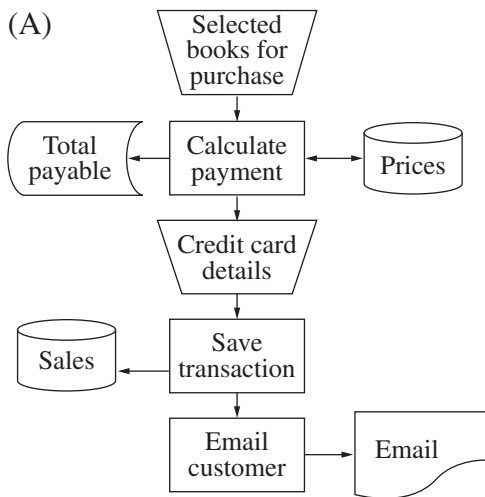

Use this information to answer Questions 17–18.

A database is being designed for a video store. At any one time, a video can only be borrowed by one customer but the customer may borrow more than one video at a time.

The diagram below describes some components already identified for the database. The Barcode field is a unique identification for each video cassette, and MovieID is a unique identification for each movie. For example, there may be many copies of the same movie in the video store. Copies of the movie will have different barcodes but the same MovieID.

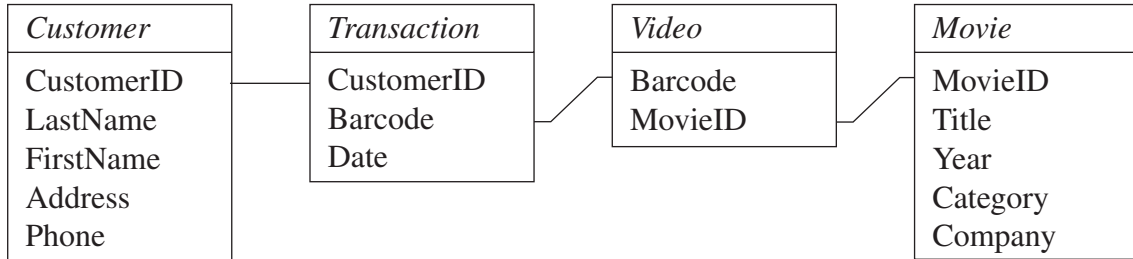

17 What are the relationships between the Customer and Transaction tables, the Transaction and Video tables, and the Video and Movie tables?

	<i>Customer–Transaction</i>	<i>Transaction–Video</i>	<i>Video–Movie</i>
(A)	many to one	many to one	one to many
(B)	many to one	one to many	one to many
(C)	one to many	one to many	many to one
(D)	one to many	many to one	many to one

18 The video store wishes to produce a report identifying the titles of the top-ten movies rented in the last month.

Which tables will need to be used?

- (A) *Transaction, Movie*
- (B) *Movie, Video, Customer*
- (C) *Movie, Video, Transaction*
- (D) *Customer, Transaction, Video, Movie*

Use this information to answer Questions 19–20.

A packet was transmitted containing three data bytes and a checksum. The last bit of each data byte is a parity bit. The checksum is calculated by adding up the number of ‘1’ bits in the data bytes.

During transmission, two of the three data bytes were corrupted. A ‘1’ bit was changed to a ‘0’ in one of them and a ‘0’ bit was changed to a ‘1’ bit in the other.

The diagram below shows the result of the transmission of the three bytes with the two errors.

10110001	11100010	11000100	00001011
First Byte	Second Byte	Third Byte	Checksum

19 Which error detection method(s) would indicate that the packet contained errors?

- (A) Parity checking but not checksum
- (B) Checksum but not parity checking
- (C) Both parity checking and checksum
- (D) Neither parity checking nor checksum

20 Which parity was used, and which two of the data bytes in the packet were corrupted during transmission?

	<i>Parity</i>	<i>Corrupted data bytes</i>
(A)	Even	first and second
(B)	Even	second and third
(C)	Odd	first and second
(D)	Odd	second and third

Section II

40 marks

Attempt Questions 21–24

Allow about 1 hour and 10 minutes for this section

Answer each question in a SEPARATE writing booklet. Extra writing booklets are available.

If you include diagrams in your answer, ensure that they are clearly labelled.

Marks

Question 21 (10 marks) Use a SEPARATE writing booklet.

A primary school is considering the introduction of a lunch-ordering information system. Students will be able to place their orders via a computer and their school accounts will be charged. Order details are stored in the Lunch-Orders table. A canteen worker will generate:

- printed orders for packing and delivery of lunches;
- receipts for the students; and
- a summary for the school administration department for charging to student accounts.

The Lunch-Orders table contains the following details:

<i>Field</i>	<i>Example</i>
Order Number	C612
Student Identification	0013 (which is linked to the Students table)
Date Ordered	12/05/2004
Food Choice Code	F015 (which is linked to the Food table)

- (a) Construct a data dictionary to describe the data to be stored in the Lunch-Orders table. **3**
- (b) Draw a dataflow diagram to describe the new information system, including the processes of: **3**
- ordering lunch
 - printing orders
 - packing and delivery.
- (c) Explain TWO ways a prototype may be used to aid the development of the new information system. **4**

Question 22 (9 marks) Use a SEPARATE writing booklet.

Two council libraries have different solutions to networking their computer resources. Both libraries provide access to different categories of users including members of the general public, librarians and council employees. Library *A* has a ring network with five computers and a shared printer. Library *B* has a bus network with six computers, two shared printers and an internet server.

- (a) For each library: **3**
- draw a diagram to represent the network topology;
 - identify an appropriate protocol for the network topology.

Clearly label Library *A* and Library *B* in your diagrams.

- (b) Describe ONE task for user management and ONE task for security management, performed by a network administrator at either of the libraries. **3**
- (c) People use library computer facilities to access the internet to collect information for research purposes. Discuss TWO issues that internet users need to consider for the responsible use of this information. **3**

Question 23 (12 marks) Use a SEPARATE writing booklet.

The organisers of an annual Fun Run propose to use information technology to calculate finishing times for all runners. The runners will have a timing device attached to their shoes before the race. Computerised timing mats will be at the start and finish lines to record accurately each runner's time. A list of the final results for all runners will only be available on the Fun Run's website.

- (a) Describe ONE social issue and ONE ethical issue related to the display of results on the website. **3**
- (b) Describe each of the following components in the context of the proposed information system, and explain how these components interact to achieve the goals of the information system: **5**
- purpose
 - participants
 - data/information
 - information technology
 - collecting.
- (c) Describe criteria that could be used to judge the success of the new information system and how to determine if the criteria have been met. **4**

Question 24 (9 marks) Use a SEPARATE writing booklet.

The diagram below shows the network communication links between a large department store, its suppliers, customers and employees.

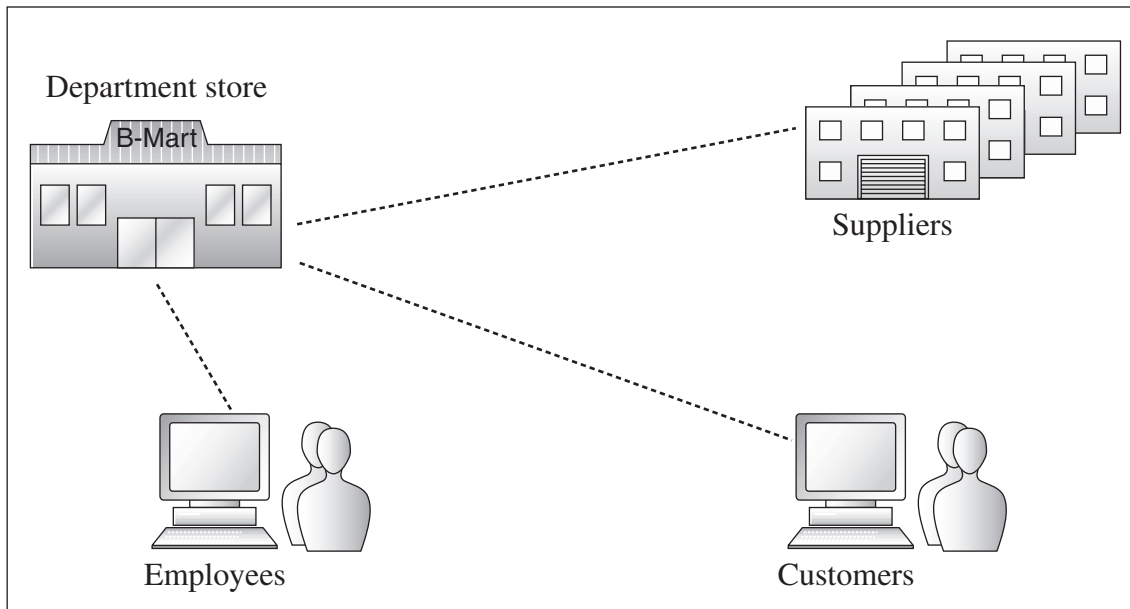

The department store sells a variety of products such as clothing, household items, toys, sports equipment and electronic products. Customers can purchase the products in the store or online. A database is used to record orders and stock levels.

The department store requires its suppliers to monitor the department store’s database using the network. Suppliers deliver goods when stock levels are low in the department store and update the database. Requests for payment from the suppliers are sent over communication links, and electronic payments are made by the department store.

The different parties (suppliers, employees of the store and customers) communicate with the department store via the internet and the store’s intranet.

- (a) Describe how the use of internet and intranet technology best supports communication between the different parties and the department store. **4**

- (b) Data in the department store’s stock database can be accessed and modified by the suppliers. Discuss issues that could arise regarding: **5**
 - accuracy of data
 - ownership and control of data.

Section III

40 marks

Attempt TWO questions from Questions 25–28

Allow about 1 hour and 10 minutes for this section

Answer each question in a SEPARATE writing booklet. Extra writing booklets are available.

If you include diagrams in your answer, ensure that they are clearly labelled.

	Marks
Question 25 — Transaction Processing Systems (20 marks) Use a SEPARATE writing booklet.	
(a) (i) Define <i>data integrity</i> and briefly describe ONE measure that may help to ensure data integrity.	3
(ii) Define <i>data warehouse</i> and describe its purpose.	3
Use the following information to answer parts (b)–(c).	
One of Australia’s largest organisations recently conducted the country’s biggest e-voting project, allowing its 2 million members to vote via the internet.	
Each voter was sent a personal identification number (PIN) by post. The voter logged onto a secure website with his/her membership number and PIN before the voting deadline. The e-voting system checked that the user had completed all voting details correctly according to voting rules. Once the vote was accepted, the voter’s details were ‘tagged’ to prevent multiple voting, and a confirmation was generated for the voter.	
(b) Describe the e-voting transaction processing system in terms of the information processes of: <ul style="list-style-type: none">• collecting;• storing;• processing the ‘tagging’ of voter details and counting of votes.	6
(c) (i) Outline backup procedures suitable for this e-voting transaction processing system so that no votes will be lost in the event of a system failure.	3
(ii) Analyse this e-voting transaction processing system to determine both its strengths and its weaknesses.	5

Question 26 — Decision Support Systems (20 marks)

Use a SEPARATE writing booklet.

- | | | | |
|-----|------|----------------------------------------------------------------------------------------|----------|
| (a) | (i) | Using an example, describe the term <i>unstructured situation</i> in decision support. | 3 |
| | (ii) | Define <i>what-if model</i> and give an example of where it is used. | 3 |

Use the following information to answer parts (b)–(c).

A company wants to develop a more systematic approach to hiring its employees. The approach will have two stages.

Stage 1

This stage consists of a decision support system (DSS). The DSS takes data supplied by a job applicant, and produces a score. The higher the score, the more suitable is the applicant.

The DSS is being developed as a spreadsheet. Only two factors are being considered in the spreadsheet. One factor is ‘travelling time’. If an applicant can travel to work within a specified time, the applicant scores 10 points, otherwise they score 0 points. The specified time should be given as data in the spreadsheet, and can be changed according to future circumstances.

The other factor is ‘experience’. Applicants score points depending on the number of years they have worked. The number of years is divided into three bands. The bands are not specified, but should be given as data in the spreadsheet. For example, the lower band might be 1–4 years of experience (scoring 10 points), the middle band might be 5–9 years of experience (scoring 20 points), and the third band might be 10 or more years of experience (scoring 50 points).

Stage 2

This stage of the hiring process involves the job applicant being interviewed. The interviewer takes the score calculated by the spreadsheet, and adds or subtracts points to reach a final score.

- | | | | |
|-----|--------------------------------------------------------------------------------------|-----------------------------------------------------------------------------------------------------------------------------------------------------------|----------|
| (b) | Design a spreadsheet template for the DSS, showing ALL relevant labels and formulae. | 6 | |
| (c) | (i) | Describe how an expert system could be used to perform the company’s hiring process. | 3 |
| | (ii) | Analyse the proposed hiring system, taking into account both the decision support system and the interview process to determine strengths and weaknesses. | 5 |

Question 27 — Automated Manufacturing Systems (20 marks)

Use a SEPARATE writing booklet.

- | | | | |
|-----|------|-------------------------------------------------------------------------------------------------------|----------|
| (a) | (i) | Define <i>CAD/CAM</i> and describe an example of its use in an automated manufacturing system. | 3 |
| | (ii) | Define the term <i>noise</i> and describe how it may be reduced in an automated manufacturing system. | 3 |

Use the following information to answer parts (b)–(c).

Aussie Electricals is a company that manufactures washing machines. Each washing machine consists of parts that need to be assembled to produce the final product. The company uses assembly line production in which some tasks, such as spray painting and packing, are performed by robotic arms, and other tasks, such as fitting panels and small parts and labelling, are performed by humans.

Some parts of the washing machines are produced by other companies. Aussie Electricals keeps a database on the quantity of each part so that re-ordering can be done before stocks run out. Information about production times, machine maintenance, faults in production and total number of washing machines produced over time is kept by the system.

- | | | | |
|-----|-------------------------------------------------------------------------------------------------------------------------------------------------------------------------|-------------------------------------------------------------------------------------------------------------------|----------|
| (b) | Explain how each of the following could be used in the automated manufacturing system at Aussie Electricals: | 6 | |
| | <ul style="list-style-type: none">• TWO types of sensors;• TWO types of actuators;• barcodes and barcode readers in inventory tracking. | | |
| (c) | (i) | Explain how over-damping and under-damping may occur in the automated manufacturing system at Aussie Electricals. | 3 |
| | (ii) | Analyse the automated manufacturing system at Aussie Electricals to determine its strengths and weaknesses. | 5 |

Please turn over

Question 28 — Multimedia Systems (20 marks)

Use a SEPARATE writing booklet.

- (a) (i) Define *bit depth* and describe how bit depth allows the representation of colour in multimedia systems. **3**
- (ii) Identify and contrast TWO methods of compression of image files. **3**

Use the following information to answer parts (b)–(c).

Smartville Local Council publishes a paper-based annual report at the end of each year and mails it to all ratepayers. It has been proposed that this annual report be replaced by a website that would display:

<i>Members of council</i>	Showing contact details and photographs of the mayor and three councillors
<i>A financial report</i>	Showing income and expenditure of the council
<i>Council services</i>	Including garbage disposal, interpreter and emergency maintenance
<i>Tourist attractions</i>	Displaying video clips of the two most popular destinations in the council area, High Park and Long River

- (b) Draw a storyboard for this proposed website. Label the major design elements for each webpage and indicate the relationships between the webpages. **6**
- (c) (i) Describe how the designers of this website would use this storyboard. **3**
- (ii) Analyse the proposed web-based solution to determine its strengths and weaknesses. **5**

End of paper