



STUDENT NUMBER

CENTRE NUMBER

HIGHER SCHOOL CERTIFICATE EXAMINATION

1997

INDUSTRIAL TECHNOLOGY

2 UNIT

SECTION III—WOOD

*Total time allowed for Sections I, II, and III—One hour and a half
(Plus 5 minutes reading time)*

DIRECTIONS TO CANDIDATES

- Write your Student Number and Centre Number at the top right-hand corner of this page.
- Where appropriate, show working for solutions neatly and clearly.
- You may use Board-approved drawing instruments and calculators.

Section III—Wood

- Attempt ALL questions.
- Answer questions in the spaces provided in this paper.

EXAMINER'S USE ONLY

| Question | | | |
|----------|--|--|--|
| 13 | | | |
| 14 | | | |
| 15 | | | |

QUESTION 13. (5 marks)

EXAMINER'S
USE ONLY



A barbecue trolley made from an Australian hardwood is shown in Figure 1. It is designed to accommodate a four-burner gas cooktop.

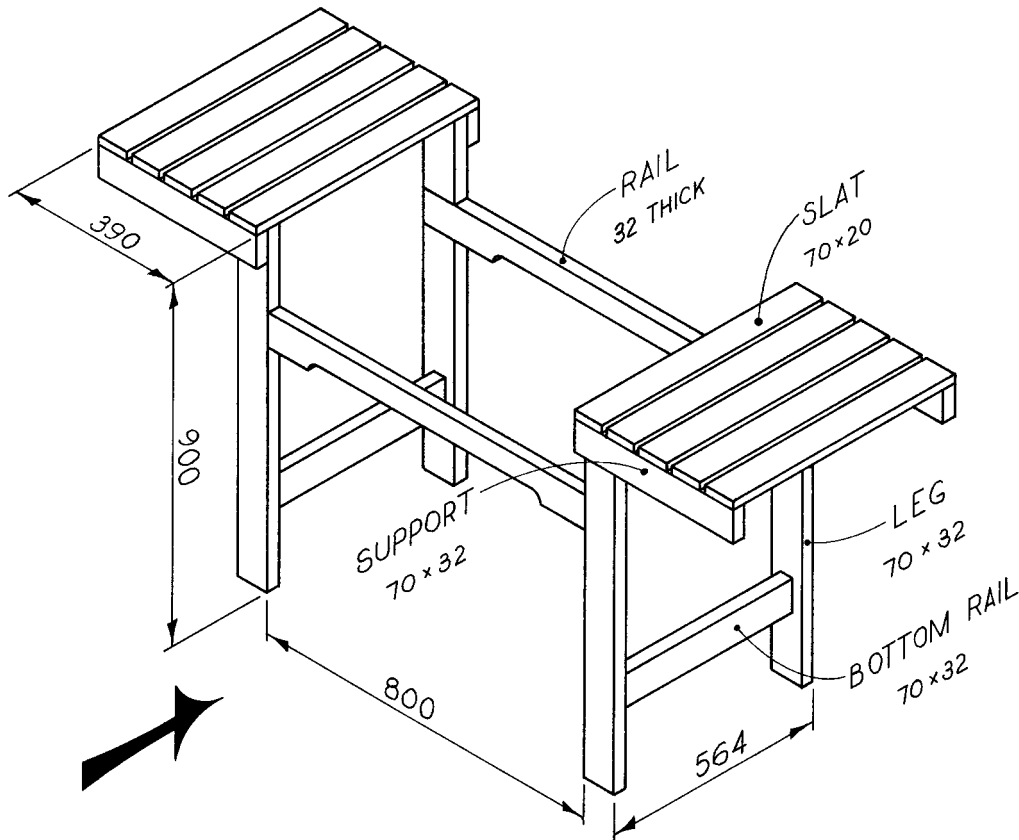

FIG. 1

(a) For the barbecue trolley to be successfully manufactured, careful planning must be undertaken.

(i) List TWO functional considerations when designing a barbecue trolley.

1.
2.

(ii) Timber is available in a standard range of cross-sectional sizes. Explain how this will impact on the design development of the barbecue trolley.

.....

QUESTION 13. (Continued)

EXAMINER'S
USE ONLY

- (b) Using the sizes given in Figure 1 and a scale of 1 : 10, complete the front and top views of the barbecue trolley commenced in Figure 2 below.

NOTE. DO NOT dimension the completed orthogonal drawing.
DO NOT show hidden detail.

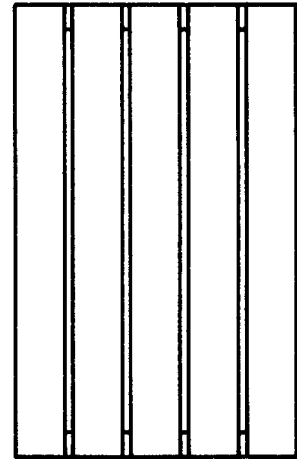

TOP VIEW

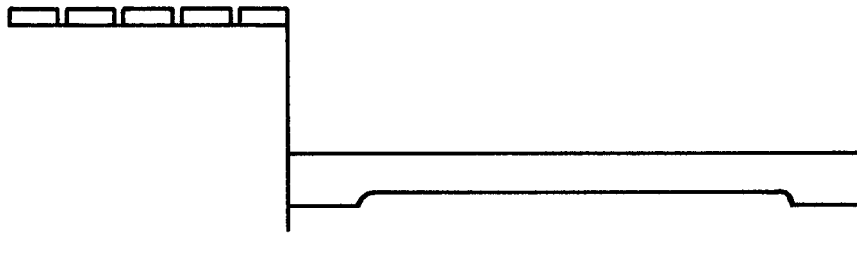

FRONT VIEW

SCALE 1 : 10

FIG. 2

Question 13 continues on page 4

QUESTION 13. (continued)

EXAMINER'S
USE ONLY

- (c) Complete the following cutting list and costing of the basic frame shown in Figure 1. No allowances should be made for waste. The cost of 70 × 32 DAR hardwood is \$6.50 per metre.

| <i>Part</i> | <i>L</i> | <i>W</i> | <i>T</i> | <i>Required</i> | <i>Cost</i> |
|-------------|----------|----------|----------|-----------------|-------------|
| Leg | | 70 | 32 | | |
| Rail | 800 | 70 | 32 | 2 | |
| Support | | 70 | 32 | | |

- (d) What information must be included on a timber order to purchase the required material?

.....

- (e) (i) Name TWO Australian hardwoods that would be suitable for the barbecue trolley.

1.
 2.

- (ii) Name the predominant large cells that are found in hardwoods.

.....

QUESTION 14. (5 marks)

EXAMINER'S
USE ONLY



- (a) A tee-halving joint, as used in the barbecue trolley, is shown in Figure 3 below.

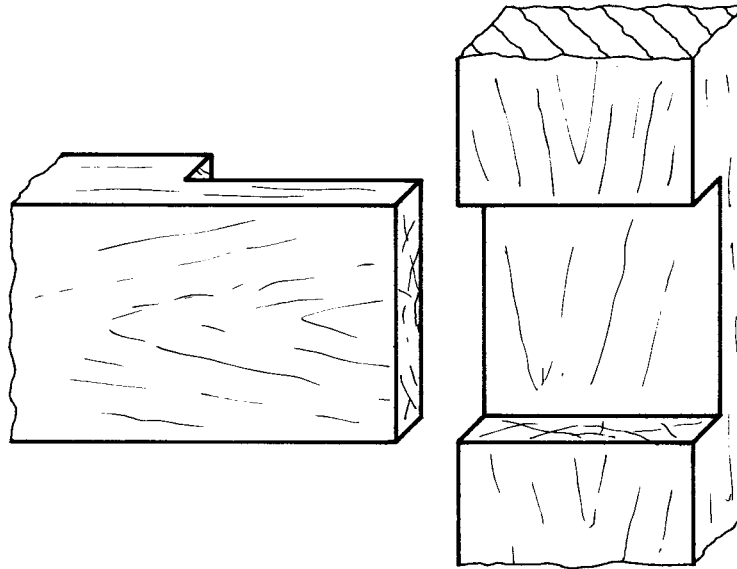

FIG. 3

- (i) List the tools required to produce this joint by hand.

.....
.....
.....
.....

- (ii) Name a machine tool that would be used in industry to produce the joint.

.....

- (iii) Explain why some machine production methods have an advantage over hand-tool methods.

.....
.....
.....
.....
.....

QUESTION 14. (Continued)

EXAMINER'S
USE ONLY

- (iv) Name a suitable adhesive for the assembly of the joint, and give a reason for your choice.

Adhesive

Reason for choice

.....
.....

- (b) Figure 4 shows a cross-section of a barbecue trolley leg.

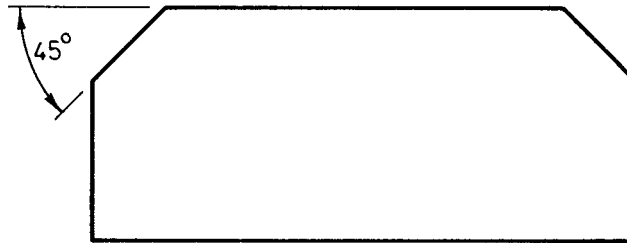

SCALE 1 : 1

FIG. 4

Name the edge treatment shown in Figure 4.

.....

QUESTION 14. (Continued)

EXAMINER'S
USE ONLY

(c) A hand plane may be used to produce the edge treatment shown in Figure 4.

(i) Explain the function of the following parts of a hand plane.

- 1. Cap iron
-
- 2. Lever cap
-

(ii) Describe the procedure to sharpen a plane edge that has become 'dull'.

.....

.....

.....

.....

(d) Figure 5 shows the cross-section of an alternative edge treatment for the barbecue trolley legs.

(i) Complete the sketch of the router cutter that would be used to produce this profile.

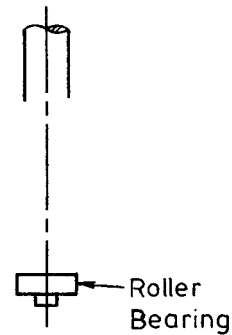
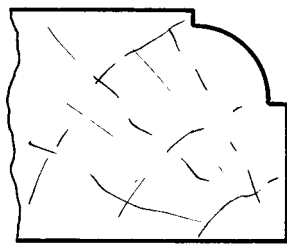

FIG. 5

(ii) Explain the role of the roller bearing on the router cutter.

.....

.....

.....

QUESTION 14. (Continued)

EXAMINER'S
USE ONLY

- (e) Figure 6 shows detail of attaching the slats to the barbecue frame shown in Figure 1.

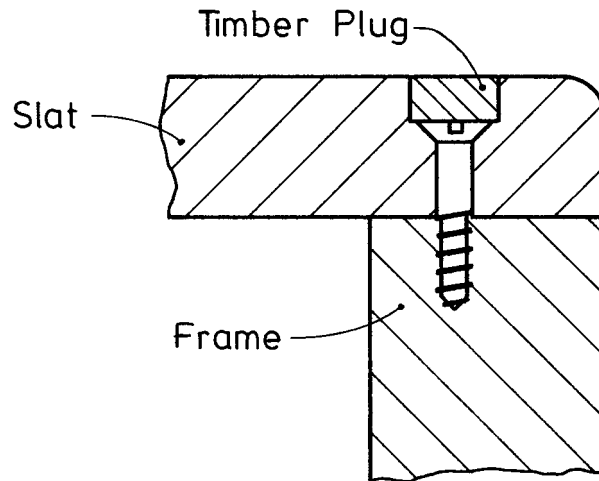

FIG. 6

- (i) What is the purpose of using a timber plug as shown in Figure 6?

.....
.....
.....

- (ii) Name the type of screw shown in Figure 6, and state a suitable size.

Screw type

Size

QUESTION 14. (Continued)

EXAMINER'S
USE ONLY

(f) Figures 7 and 8 show equipment commonly found in wood industry workshops.

(i) Name each machine tool, and describe its specific function in the production of the barbecue trolley shown in Figure 1.

Name

Function

.....
.....
.....
.....
.....

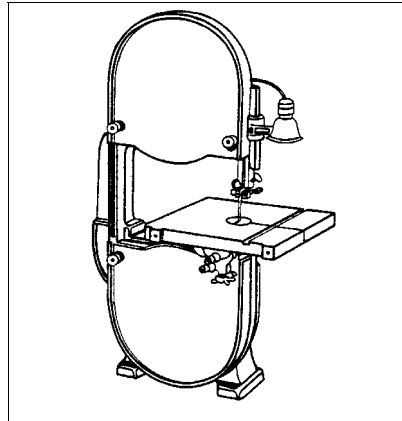

FIG. 7

Name

Function

.....
.....
.....
.....
.....

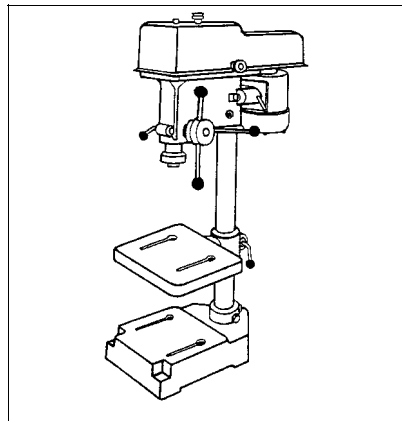

FIG. 8

'Step-by-step Woodwork Projects', GJ Englebrecht, Struik Publishers, 1995, p10.

(ii) Safety is an important issue to management and workers in industry. Using specific examples from Figures 7 and 8, discuss the importance of safety guards.

.....
.....
.....
.....
.....
.....

QUESTION 15. (5 marks)EXAMINER'S
USE ONLY

A manufacturer wishes to design a tray to accompany the barbecue. The tray will provide a permanent home for the range of six condiments (listed below) and will also have free space for carrying food from the kitchen to the barbecue area.

All condiments are in glass jars with sizes shown in Figure 9.

Condiments include

- | | |
|--------------------|-----------------|
| 1. Garlic salt | 4. Season All |
| 2. Steak seasoning | 5. Lemon pepper |
| 3. Mixed herbs | 6. Basil |

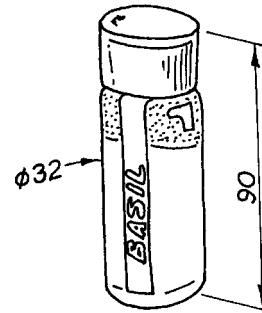

FIG. 9

- (a) Make a freehand sketch of a suitable tray. Various sections of Australian hardwood timber, and 4 mm thick matching plywood, are available.

Indicate:

- the method used to hold the condiments;
- the overall sizes of the tray;
- details of all joints used in construction.

QUESTION 15. (Continued)

EXAMINER'S
USE ONLY

- (ii) Explain a method of removing the arris from the inside edge after shaping.

.....
.....

- (d) If your tray design was found to be too heavy, list THREE options that you could use to help overcome this problem.

- (i)
- (ii)
- (iii)