

Past Paper

BioMedical Admissions Test

Time allowed: 30 minutes

SECTION 2 Scientific Knowledge and Applications

Instructions to Candidates

Please read this page carefully, but do not open the question paper until you are told that you may do so.

A separate answer sheet is provided for this section. Please check you have one. You also require a soft pencil and an eraser.

Please first write your name, date of birth, BioMedical Admissions Test candidate number and centre number in the spaces provided on the answer sheet. Please write very clearly.

Speed as well as accuracy is important in this section. **Work quickly, or you may not finish the paper.** There are no penalties for incorrect responses, only points for correct answers, so you should attempt all 27 questions. Unless otherwise stated, all questions are worth one mark.

Answer on the sheet provided. Many questions ask you to show your choice between options by shading a circle (or circles, if specified in the question). If questions ask you to write in words or numbers, be sure to write clearly in the spaces provided. If you make a mistake, erase thoroughly and try again.

Any rough work should be done on this question paper.

Calculators are NOT permitted.

Please wait to be told you may begin before turning this page.

This paper consists of 15 printed pages and 5 blank pages.

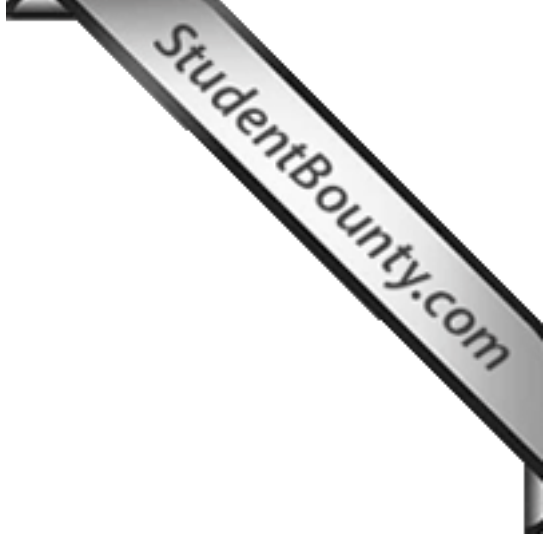

BLANK PAGE

- 1 The table shows the percentages of some substances measured in fluid taken from a human kidney.

substance	%
water	99
proteins	0
glucose	0.1
urea	0.03

Which letter on the diagram shows the most likely source of the fluid?

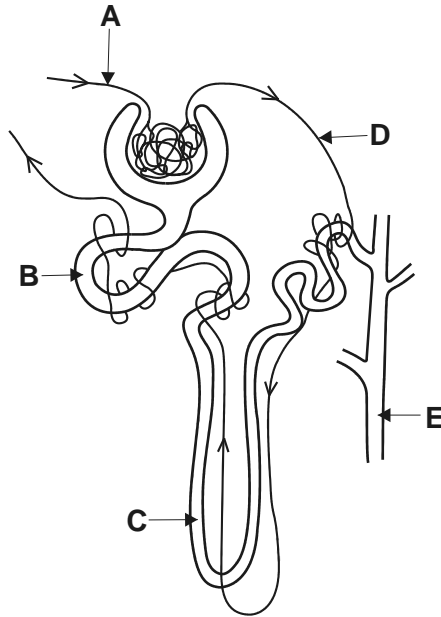

- 2 Element **x** is in the second period of the Periodic Table. An atom of element **y** has six more protons than an atom of element **x**.

Which statement must be correct?

- A** Elements **x** and **y** are in the same period of the table.
- B** Elements **x** and **y** have the same number of electrons in the first shell.
- C** Element **y** has six more electrons in its outer shell than does element **x**.
- D** The nucleon number of element **y** is six more than that of element **x**.

- 3 A detector of radioactivity shows background radiation to be 20 counts per minute with no radioactive sources nearby. A radioactive source which emits alpha particles and beta particles is brought very close to the detector and the detector reading increases to 280 counts per minute. A sheet of paper is then placed between the source and the detector, and the detector reading drops to 60 counts per minute.

How many counts per minute were caused by alpha particles and by beta particles from the source?

- 4 The equation connects the variables A , x , y , z , P and Q .

$$A = \frac{(x + y)^2 z}{P} Q$$

The following changes are made:

x and y are both increased by 50%

z is decreased by 20%

P is doubled and Q remains the same.

What is the resulting percentage change in A ?

- A 10% decrease
- B 10% increase
- C 2.5% increase
- D 2.5% decrease
- E 20% decrease
- F 20% increase

- 5 The three statements below are about exhaling.
- 1 The ribs swing down and inwards during exhaling.
 - 2 The diaphragm muscles contract during exhaling.
 - 3 The pressure in the lungs increases during exhaling.

Which statements are correct?

- A 1 only
 - B 2 only
 - C 3 only
 - D 1 and 2 only
 - E 1 and 3 only
 - F 2 and 3 only
- 6 The oscillation period, t , for a spiral spring (weight w , radius R made from wire length l , radius r with a modulus of rigidity n) with a weight W hanging from it is given by:

$$t = 2\pi \sqrt{\frac{2lR^2(W + w/3)}{n\pi r^4 g}}$$

If such a spring is used to measure the weight, W , of an object we need to rearrange the equation so W is the subject.

Which of the following is the correct rearrangement of the equation?

- A $W = \frac{nr^4 gt^2}{8\pi R^2} - \frac{w}{3}$
- B $W = \frac{n\sqrt{\pi} r^4 gt^2}{8lR^2} - \frac{w}{3}$
- C $W = \frac{3nr^4 gt^2}{8\pi R^2} - 3w$
- D $W = \frac{n\sqrt{\pi} r^4 gt^2}{8lR^2} - 3w$

- 7 A 100 % efficient transformer has 1500 turns on its primary coil. The input to the transformer is 250 V ac. The output current is 10 A and the output power is 0.5 kW.

What is the number of turns on the secondary coil?

- 8 An oxide of iron has the formula Fe_3O_4 and contains both Fe^{2+} and Fe^{3+} ions.

Which one of the following is the fraction of iron ions that are in the Fe^{2+} state?

- A $\frac{1}{4}$
 B $\frac{1}{3}$
 C $\frac{1}{2}$
 D $\frac{2}{3}$
 E $\frac{3}{4}$

- 9 Which row of the table shows the state of the heart valves when the heart pumps blood to the lungs?

	left side of heart		right side of heart	
	atrio-ventricular valve (cuspid)	semilunar valve	atrio-ventricular valve (cuspid)	semilunar valve
A	closed	closed	open	open
B	closed	open	closed	open
C	closed	open	open	closed
D	open	closed	closed	open
E	open	closed	open	closed
F	open	open	closed	closed

- 10 The reaction between lead(II) nitrate solution and potassium iodide solution is shown below:

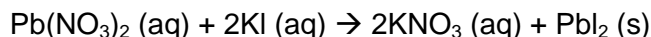

When the two solutions are mixed in a test tube the height of the lead(II) iodide precipitate formed can be measured.

Which combination of solutions would produce the greatest height of the precipitate?

	lead(II) nitrate solution		potassium iodide solution	
	volume/cm ³	concentration/ mol dm ⁻³	volume/cm ³	concentration/ mol dm ⁻³
A	5.0	2.0	10.0	2.0
B	2.5	5.0	2.5	5.0
C	7.5	3.0	5.0	5.0
D	5.0	4.0	7.5	5.0

- 11 Below are four statements about thermal (heat) energy.

- 1 A substance can lose heat energy without its temperature falling.
- 2 Heat energy can pass through a vacuum.
- 3 Steam at 100°C has more heat energy than the same mass of boiling water at 100°C
- 4 When a container of water is cooled near the top, a convection current is set up in the water.

Which statements are true?

- A** 1, 2 and 3
- B** 2, 3 and 4
- C** 1, 2 and 4
- D** 1, 3 and 4
- E** all of the statements

- 12 The box and whisker plot shows some information about members of a health club using a walking machine. It shows the number of steps that a group of 30 members did in a period of 10 minutes.

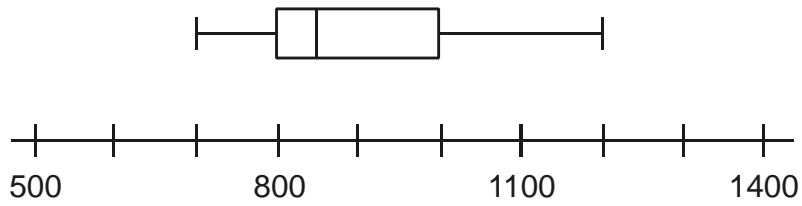

Use this information to find the probability that when 3 of these 30 members are chosen at random, they will all have taken between 850 and 1000 steps.

- A $\frac{3}{4}$
- B $\frac{150}{500}$
- C $\frac{1}{8}$
- D $\frac{3}{30}$
- E $\frac{1}{64}$

- 13 The diagram shows the bones and leg muscles of a person standing on their toes. The bones and muscles are acting as a lever system.

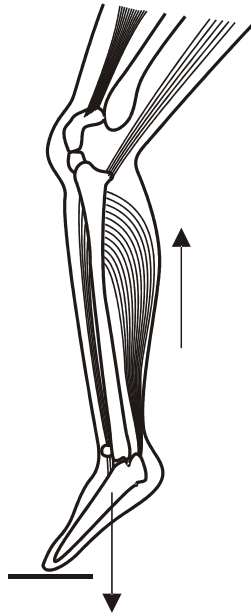

Which of the following is the correct description of this lever system?

- A The fulcrum is between the effort and the load.
 - B The load is being exerted by the calf muscle.
 - C The load is between the fulcrum and the effort.
 - D The effort is exerted by the muscles in the foot.
 - E The effort is between the load and the fulcrum.
- 14 Which of the following reactions between a Group 1 element and a Group 7 element would be the most exothermic?
- A caesium and fluorine
 - B lithium and iodine
 - C potassium and bromine
 - D sodium and chlorine

- 15 Which diagram shows how a ray of white light is refracted by an air bubble in water, and gives the correct relative positions of the red and violet light formed by dispersion?

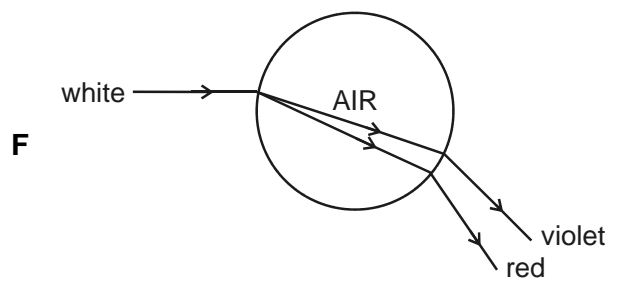
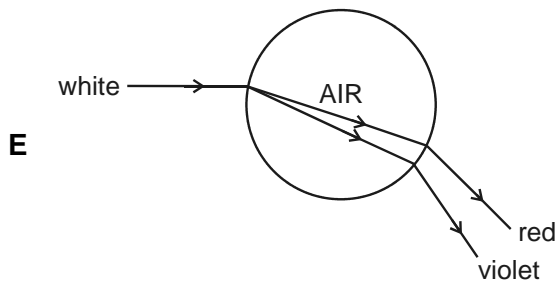
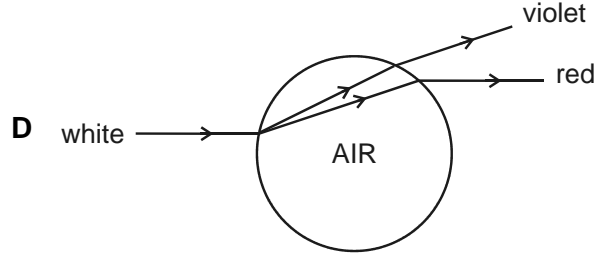
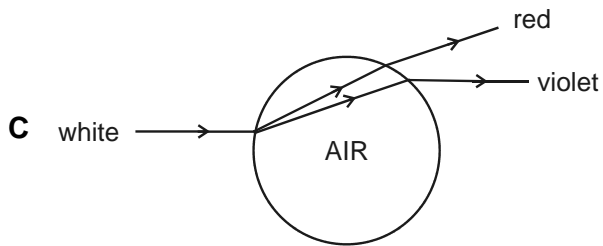
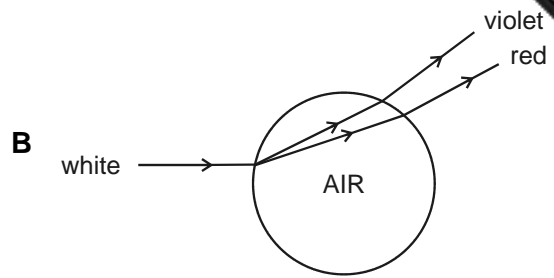
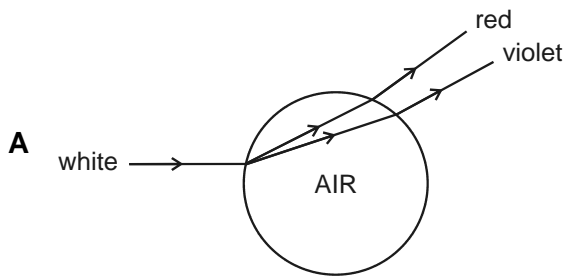

- 16 The two inequalities given below define an area on a graph.

$$y \geq x^2 + 3$$

$$x \geq 1/y$$

Which one of the following points lies within the area defined?

- A** (-1, -6)
- B** (2, -1)
- C** (1, 6)
- D** (2, 2)

- 17 The below diagram shows a family tree of a condition known as nail patella syndrome (NPS).

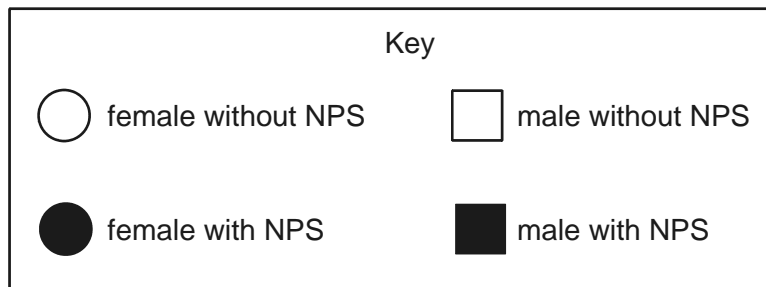
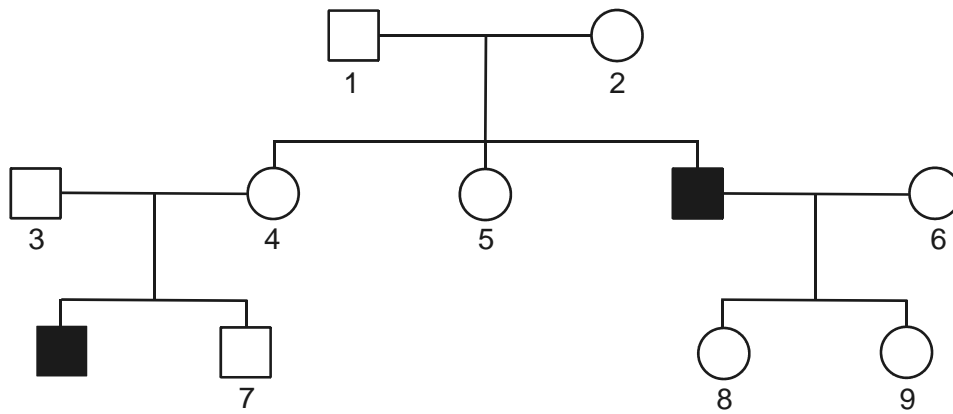

Which of the following pairs of individuals **must** be heterozygous for NPS?

- A 1 and 5
- B 2 and 6
- C 3 and 7
- D 4 and 8
- E 5 and 9
- F 6 and 7

- 18 What volume of steam would be produced from an ice cube of mass 6.00 g if it were heated until it all evaporated?

(A_r values: H = 1; O = 16)

(Take molar volume at room temperature and pressure = 24 dm³)

- A 240 cm³
 B 1800 cm³
 C 4800 cm³
 D 8000 cm³

- 19 A heavy uniform bar is in equilibrium in the arrangement shown.

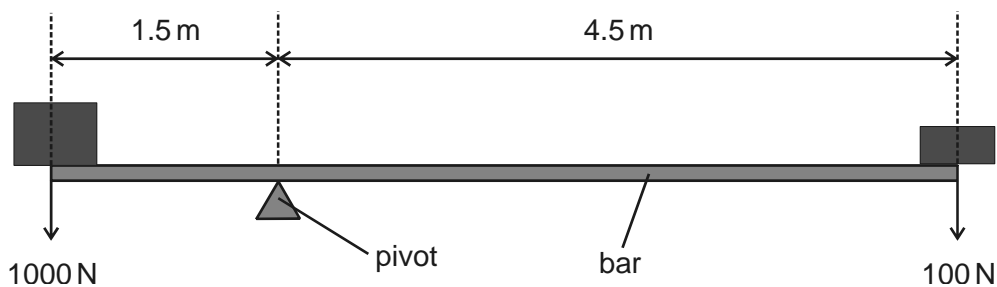

What is the weight of the bar? (Give your answer to the nearest Newton.)

- 20 The longest side of a right angled triangle is $6 + \sqrt{5}$ units.
 One of the shorter sides is $3 + 2\sqrt{5}$ units.

What is the length of the third side?

- A $2\sqrt{3}$
 B $\sqrt{70 + 24\sqrt{5}}$
 C 12
 D $3 - \sqrt{5}$
 E $14 + 7.5\sqrt{5}$

- 21 A patient with leukaemia is being treated with chemotherapy and radiotherapy. The patient is found to have a low blood platelet count and a high percentage of the white blood cells are abnormal.

Which row of the table shows this patient's symptoms?

	disease resistance	blood clotting	oxygen transport
A	low	low	low
B	high	low	high
C	low	normal	low
D	high	normal	normal
E	low	low	normal
F	high	normal	high

- 22 Some statements about ammonia are given below.

- 1 Its formula is NH_3 .
- 2 The pH of its solution in water is less than 7.
- 3 It has a molecular structure.
- 4 It turns damp blue litmus paper red.
- 5 It is a liquid at room temperature.
- 6 It is covalently bonded.

Which are correct statements about ammonia?

- A 1, 2 and 3
- B 2, 4 and 5
- C 4, 5 and 6
- D 1, 3 and 6
- E 1, 3 and 5
- F 2, 3 and 4

23 An artery has a length x mm and blood flows steadily through it at V ml per second.

If, on average, a given red blood cell takes T seconds to travel the length of the artery, what is the cross-sectional area of the artery in mm^2 ?

A $\frac{VT}{x} \times 10^{-6}$

B $\frac{Vx}{T} \times 10^{-6}$

C $\frac{VT}{x}$

D $\frac{Vx}{T}$

E $\frac{VT}{x} \times 10^3$

F $\frac{Vx}{T} \times 10^3$

- 24 The solid shown below consists of a cylinder topped by a hemisphere of the same radius.

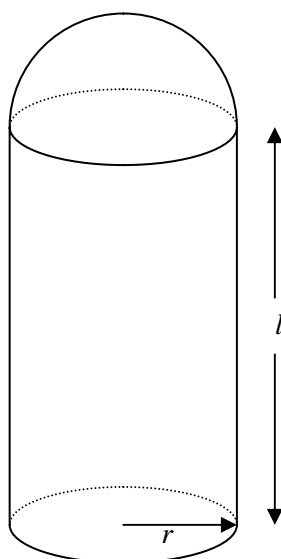

Which one of the following correctly gives the volume of this solid?

- A $\frac{\pi r^2}{3}(2r + 3l)$
- B $\frac{\pi r^2}{3}(4r + 3l)$
- C $\frac{\pi r^3}{3}(2 + 3l)$
- D $\frac{\pi r^2}{3}(2r + l)$

- 25 A mixture of equal parts of hexane (bp 68 °C) and heptane (bp 98 °C) is distilled using a fractionating column.

The temperature of the liquid in the flask and the temperature at the top of the fractionating column are measured.

Which one of the following shows the likely temperatures when the first drops of distillate are collected?

	temperature in flask/°C	temperature at top of column/°C
A	83	68
B	98	68
C	83	83
D	98	83

- 26 Which row of the table shows the roles of the female sex hormones in controlling the menstrual cycle?

	causes thickening of lining of uterus	maintains lining of uterus	causes break down of lining of uterus
A	fall in oestrogen concentration	low oestrogen concentration	rise in progesterone concentration
B	fall in progesterone concentration	low progesterone concentration	rise in oestrogen concentration
C	rise in oestrogen concentration	high progesterone concentration	fall in progesterone concentration
D	rise in progesterone concentration	high oestrogen concentration	fall in progesterone concentration
E	rise in oestrogen concentration	low progesterone concentration	rise in progesterone concentration
F	fall in progesterone concentration	high progesterone concentration	fall in oestrogen concentration

- 27 The position of cobalt in the periodic table is as follows:

55 25 Mn	56 26 Fe	59 27 Co	59 28 Ni	63.5 29 Cu
----------------	----------------	----------------	----------------	------------------

Cobalt 60 is a radioactive isotope that decays with the emission of beta and gamma radiation. A beam of radiation from a cobalt 60 source is directed towards a malignant tumour in a patient's abdomen.

Which of the following is/are correct when cobalt 60 is used in this way?

- 1 The cobalt (${}_{27}\text{Co}$) is being converted into nickel (${}_{28}\text{Ni}$) as it decays.
 - 2 The tumour is attacked by the gamma radiation.
 - 3 The radiation attacks only the malignant cells.
- A 1 only
- B 2 only
- C 3 only
- D 1 and 2
- E 2 and 3
- F 1 and 3

END OF SECTION 2

BLANK PAGE

BLANK PAGE

BLANK PAGE

BLANK PAGE