

BioMedical Admissions Test

Specimen Paper 30 minutes

SECTION 2 Scientific Knowledge and Applications

Instructions to Candidates

Please read this page carefully, but do not open the question paper until you are told that you may do so.

A separate answer sheet is provided for this section. Please check you have one. You also require a soft pencil and an eraser.

Please first write your name, date of birth, BioMedical Admissions Test candidate number and centre number in the spaces provided on the answer sheet. Please write very clearly.

Speed as well as accuracy is important in this section. **Work quickly, or you may not finish the paper.** There are no penalties for incorrect responses, only points for correct answers, so you should attempt all 27 questions. Unless otherwise stated, all questions are worth one mark.

Answer on the sheet provided. Many questions ask you to show your choice between options by shading a circle (or circles, if specified in the question). If questions ask you to write in words or numbers, be sure to write clearly in the spaces provided. If you make a mistake, erase thoroughly and try again.

Any rough work should be done on this question paper.

Calculators are NOT permitted.

Please wait to be told you may begin before turning this page.

This paper consists of 11 printed pages and 1 blank page.

BLANK PAGE

- 1 The table below shows the proportions of undigested and digested carbohydrates, fats and proteins in three regions of the digestive system.

type of nutrient	mouth	stomach	small intestine
1			
2			
3			

Key
 undigested food
 digested food

Which row of the table below correctly identifies the types of nutrient 1, 2 and 3?

	1	2	3
A	protein	fat	starch
B	starch	protein	fat
C	protein	starch	fat
D	fat	protein	starch
E	starch	fat	protein
F	fat	starch	protein

- 2 Solve the equation to find the value of x .

$$\frac{x+5}{2} - \frac{2x-1}{3} = 4$$

- 3 A resistor of resistance $1.5\text{ k}\Omega$ has a voltage of 30 V applied across it. What is the current through it? (Give your answer in amperes.)
- 4 The pH of arterial blood is 7.4. Which one of the following is the likely pH of venous blood?
- A 4.35
 B 7.35
 C 7.45
 D 10.45

- 5 The diagram shows the leg muscles of an athlete leaving the starting blocks for a race.

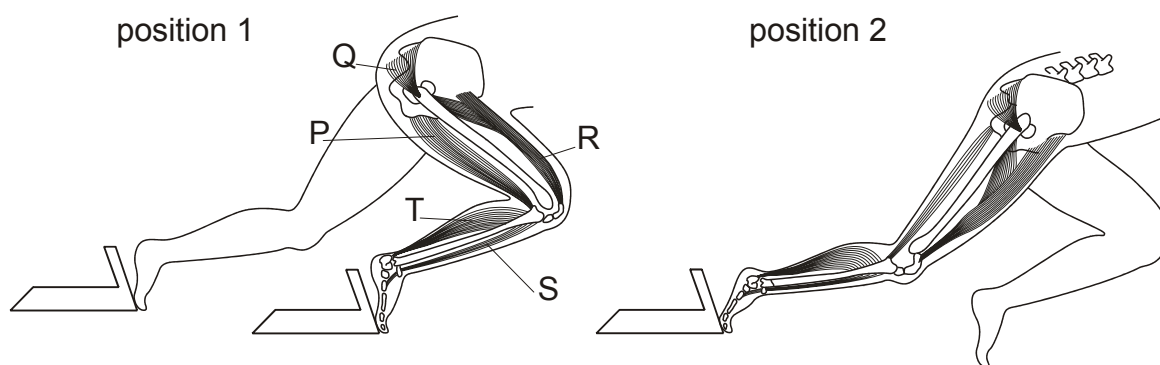

Which muscles contract and which relax to bring about the change from position 1 to position 2?

	muscles that contract	muscles that relax
A	P, Q, R	S, T
B	T, P	Q, R, S
C	Q, R, T	P, S
D	R, S	P, Q, T
E	Q, R, S	P, T

- 6 A bullet of mass 10 g travels at a speed of 200 m/s. It strikes a bullet-proof vest and is brought to rest in 1×10^{-4} s. Calculate the average force exerted on the bullet by the vest.
- 7 Vitamin C, $C_6H_8O_6$, is manufactured starting from glucose, $C_6H_{12}O_6$. The conversion of glucose to vitamin C involves which one of the following?
- A oxidation
 - B reduction
 - C hydration
 - D dehydration

- 8 The graph shows the volume of a subject's lungs measured over a period of 40 seconds.

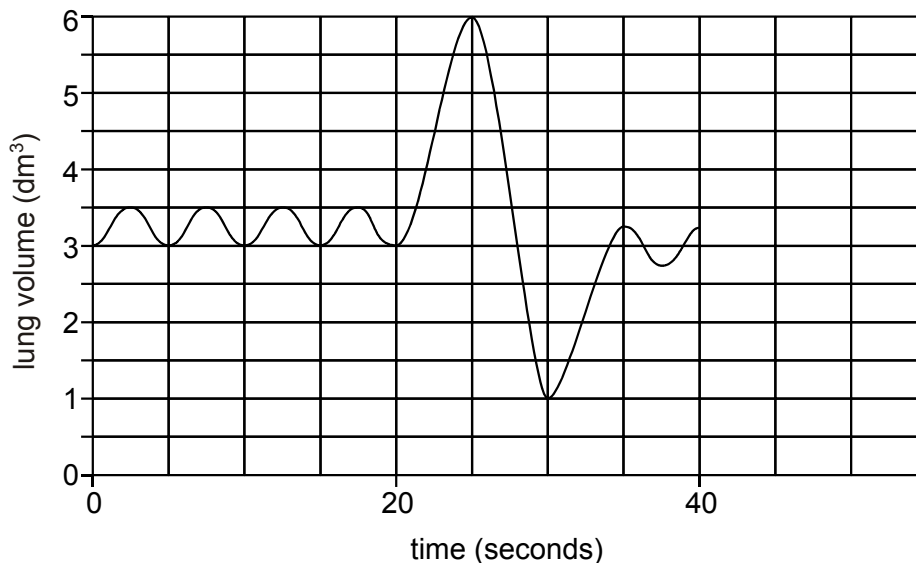

Determine the total volume of air **breathed in** during the 40 seconds (give your answer to the nearest 0.25 dm^3).

- 9 Calculate

$$\frac{3.246 \times 10^6 + 3.246 \times 10^4}{1.623 \times 10^{11}}$$

Give your answer as an **ordinary number**, correct to 3 significant figures.

- 10 The list shows parts of the nervous system that might be involved in bringing about salivation when a hungry person sees food.

- 1 brain
- 2 motor neurone
- 3 relay neurone
- 4 salivary gland
- 5 sensory neurone
- 6 spinal chord
- 7 retina

Which of the following shows the pathway of an impulse to bring about salivation?

- A $7 \rightarrow 5 \rightarrow 1 \rightarrow 4 \rightarrow 3$
- B $7 \rightarrow 2 \rightarrow 4 \rightarrow 6 \rightarrow 1$
- C $1 \rightarrow 2 \rightarrow 4 \rightarrow 7 \rightarrow 5$
- D $7 \rightarrow 5 \rightarrow 1 \rightarrow 2 \rightarrow 4$
- E $1 \rightarrow 2 \rightarrow 3 \rightarrow 6 \rightarrow 7$
- F $5 \rightarrow 6 \rightarrow 1 \rightarrow 2 \rightarrow 4$

- 11 In this circuit, the bulbs are identical. A_1 to A_4 are ammeters, and V_1 and V_2 are voltmeters.

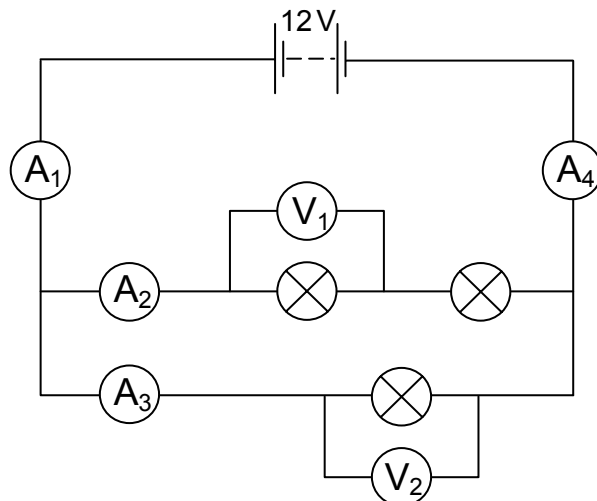

Indicate, on the answer sheet, whether each of the statements (i to v) below is **true** or **false** for the circuit shown.

- i Voltmeter V_1 reads 6 volts.
 - ii Voltmeter V_2 reads 12 volts.
 - iii Ammeter A_2 shows a higher reading than A_3 .
 - iv The reading on A_4 is less than the reading on A_1 .
 - v The reading on A_4 is the sum of the readings on A_2 and A_3 .
- 12 The diagram shows a quadrant of a circle, centre O, radius 20 cm. The chord AB has been drawn.

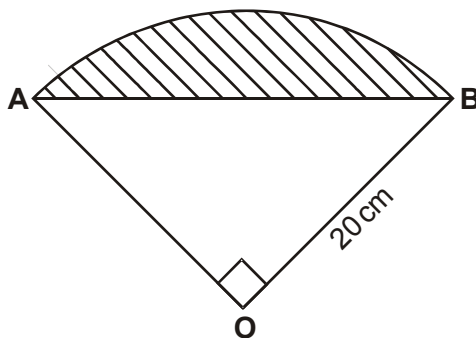

What fraction of the quadrant is shaded?

- A $\frac{\pi - 1}{\pi}$ B $\frac{2}{\pi}$ C $\frac{\pi - 2}{\pi}$ D $\frac{2 - \pi}{\pi}$

- 13 The family tree below shows monohybrid inheritance for a certain disease. The dominant allele is represented by **R** and the recessive allele by **r**.

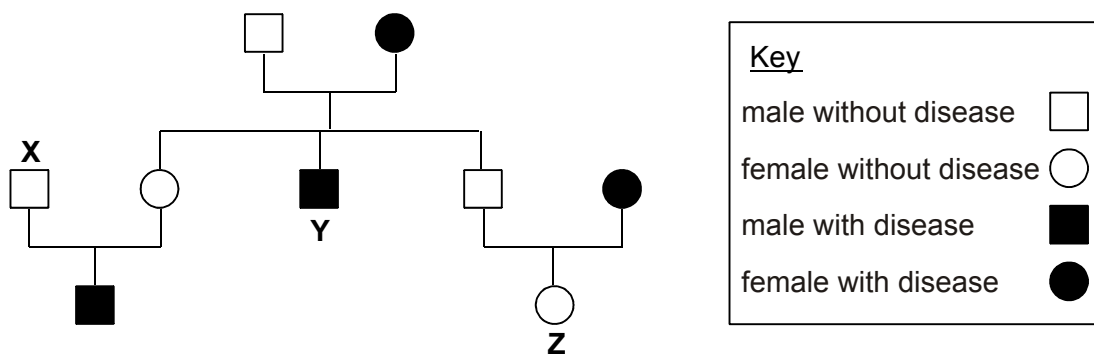

Which one of the choices below represents the genotype of individuals **X**, **Y** and **Z**?

- | | <u>Male X</u> | <u>Male Y</u> | <u>Female Z</u> |
|----------|---------------|---------------|-----------------|
| A | rr | RR | rr |
| B | rr | Rr | Rr |
| C | Rr | RR | Rr |
| D | Rr | rr | Rr |
| E | RR | rr | RR |
- 14 On complete thermal decomposition in air a sample of an unknown hydrocarbon yielded 18 g of water, 44 g of carbon dioxide and no other products. (Relative atomic masses: H = 1; C = 12; O = 16.)

Which **one** of the following might be the formula of the hydrocarbon?

- A** CH₄
B C₂H₄
C C₂H₆
D C₄H₁₀
E C₆H₁₄
- 15 A regular solid block weighs 150 N and has the dimensions shown.

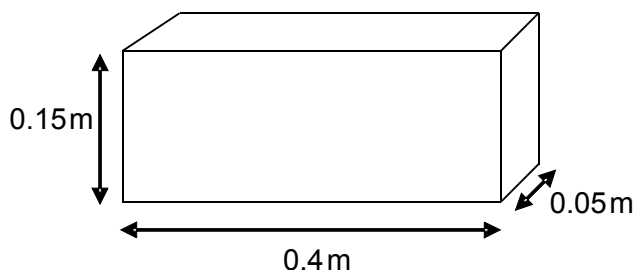

If the block can stand on any of its faces, what is the largest pressure that the weight of the block could exert on the ground?

- 16 A parachutist falls from an aircraft and reaches a terminal velocity. After a while he opens his parachute and reaches a new (lower) terminal velocity.

Which graph shows how the air resistance (drag) force acting on him varies with time during the fall?

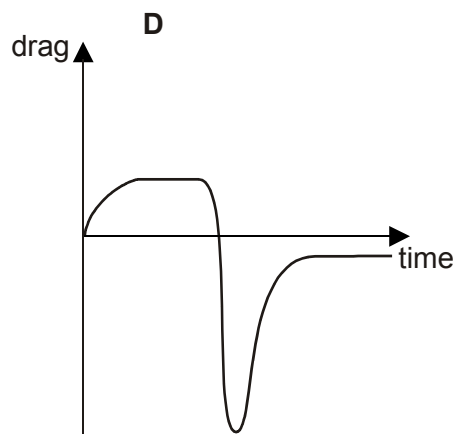
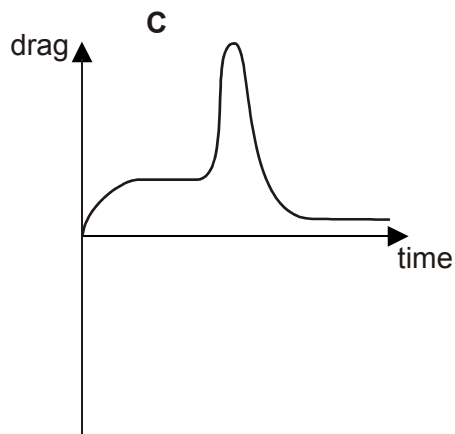
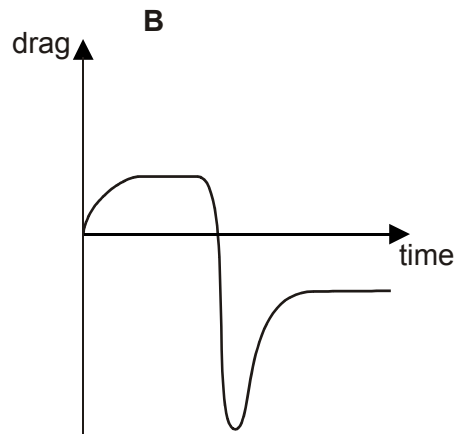
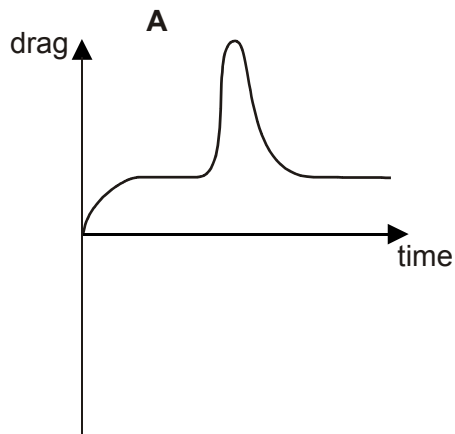

- 17 Rearrange $\sqrt{\frac{2}{x}} + 1 = y - 3$ to make x the subject.

A $x = \frac{2}{(y-4)(y-2)}$

B $x = \frac{y-4}{2}$

C $x = \frac{(y-3)^2}{2}$

D $x = \frac{2}{(y+4)(y+2)}$

- 18 The diagram represents a simplification of the human blood circulatory system supplying certain main organs.

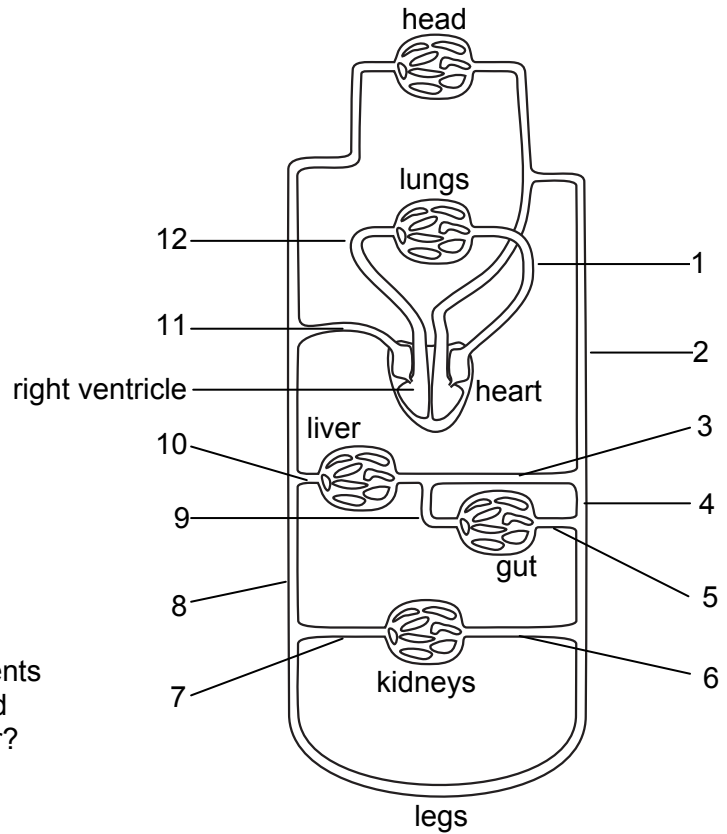

Which **one** of the following represents a path that might be taken by blood passing from the kidney to the liver?

- A 6 – 4 – 3
 B 6 – 5 – 9
 C 7 – 8 – 10
 D 7 – 8 – 11 – 12 – 1 – 2 – 3
 E 6 – 4 – 2 – 1 – 12 – 11 – 10
- 19 What values of **a**, **b** and **c** are needed to balance the equation?



- 20 A man lifts a 20kg mass through a distance of 0.5m in 2s. The acceleration of free fall is 10m/s^2 .
 What average power does he develop?

- A 5W
 B 20W
 C 50W
 D 200W

21 Many industrial processes use a catalyst to increase the rate of reaction. What advantage does the use of a catalyst have?

- A It gives a purer product.
- B It increases the maximum achievable yield.
- C It makes the reaction exothermic.
- D It saves on the energy costs.

22 The apparatus is set up as below:

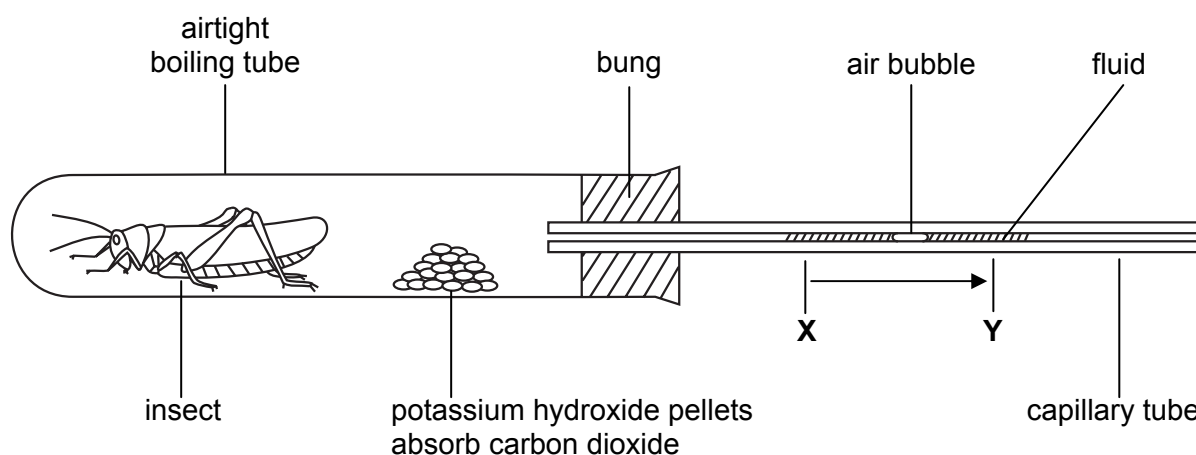

What would cause the air bubble to move from X to Y?

- A a very active insect absorbing more oxygen than it releases carbon dioxide
 - B an inactive insect evolving the same volume of carbon dioxide as oxygen absorbed
 - C a dead insect and an increase in atmospheric air pressure
 - D a dead insect and an increase in air temperature
 - E a poorly active insect absorbing less oxygen than it releases carbon dioxide
- 23 Two hydrocarbons found in crude oil are decane, $C_{10}H_{22}$, and octadecane, $C_{18}H_{38}$. Which one of the following properties of octadecane, compared to the equivalent property in decane, is correct?
- A It has a lower boiling point.
 - B It catches fire less easily.
 - C It is more volatile.
 - D It is less viscous.

- 24 A charger unit for a mobile phone contains a transformer. In use the primary coil of the transformer is connected to the mains supply and the secondary coil provides a low voltage output. If the transformer were to be re-designed to produce half the voltage output, which one of the following could achieve this?

- A fewer turns on the primary coil
- B fewer turns on the secondary coil
- C thinner wire for the primary coil
- D thinner wire for the secondary coil

- 25 AB is parallel to CD. (The diagram is not drawn to scale.)

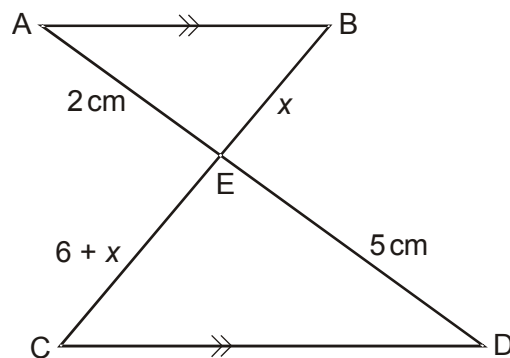

Find the length of BE.

- 26 The diagram shows the menstrual (oestrus) cycle for a human female who is not pregnant.

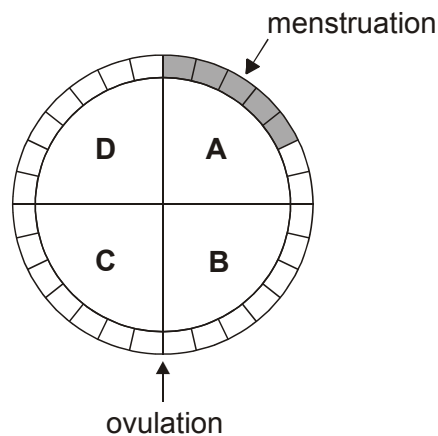

During which period, **A**, **B**, **C** or **D**, will the concentration of oestrogen reach its highest level?

- 27** The average human adult draws in 0.5dm^3 in a single breath. Assuming 80% of air is nitrogen, N_2 , and that 24dm^3 of air contains 6×10^{23} molecules, calculate the number of nitrogen atoms taken in by a single breath.
- A** 3×10^{23}
 - B** 3×10^{22}
 - C** 2×10^{22}
 - D** 1×10^{22}
 - E** 5×10^{21}

END OF SECTION 2