

4500/12

BioMedical Admissions TestWednesday 7th November 2012

30 minutes

*
2
8
5
8
8
1
0
8
9
9
SECTION 2 Scientific Knowledge and Applications*Instructions to Candidates**

Please read this page carefully, but do not open the question paper until you are told that you may do so.

A separate answer sheet is provided for this section. Please check you have one. You also require a soft pencil and an eraser.

Please complete the answer sheet with your:

- BMAT candidate number
- centre number
- date of birth
- name

Speed as well as accuracy is important in this section. **Work quickly, or you may not finish the paper.** There are no penalties for incorrect responses, only points for correct answers, so you should attempt all 27 questions. All questions are worth one mark.

Answer on the sheet provided. Most questions ask you to show your choice between options by shading a circle. If questions ask you to write in words or numbers, be sure to write clearly in the spaces provided. If you make a mistake, erase thoroughly and try again.

Any rough work should be done on this question paper.

Calculators are NOT permitted.

Please wait to be told you may begin before turning this page.

This paper consists of 21 printed pages and 3 blank pages.

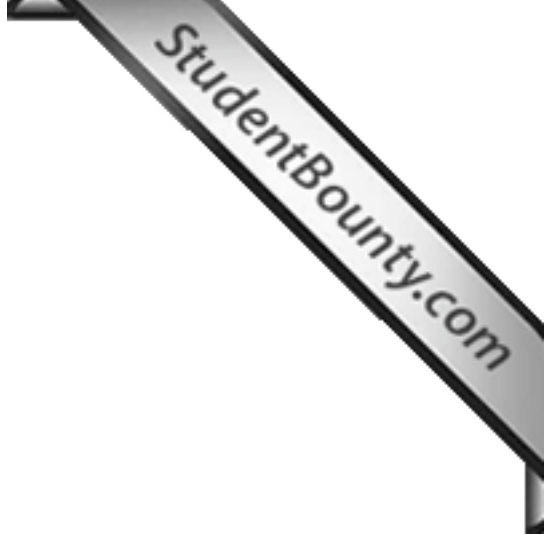

BLANK PAGE

1 Which of the following could result in a homeostatic response?

- 1 A rise in an internal condition.
- 2 A reduction in an internal condition.
- 3 A rise in an external condition.
- 4 A reduction in an external condition.

- A 1 and 2 only
- B 1 and 3 only
- C 2 and 4 only
- D 3 and 4 only
- E 1, 2 and 3 only
- F 1, 2, 3 and 4

2 2.74g of 1-bromobutane is reacted with excess aqueous sodium hydroxide to produce 1.11g of butan-1-ol according to the equation below.

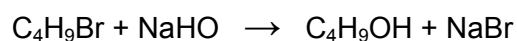

What is the percentage yield of butan-1-ol?

(A_r : H = 1; C = 12; O = 16; Na = 23; Br = 80)

- A 26%
- B 40%
- C 54%
- D 75%

- 3 Nuclide ${}^N_R X$ is an unstable isotope which decays in two stages into nuclide Z as shown

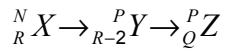

What are the values of P and Q?

	P	Q
A	N - 4	R + 1
B	N - 4	R - 1
C	N - 4	R - 2
D	N	R - 1
E	N	R - 2
F	N	R - 4

- 4 The design in the diagram is formed from four circles which all touch at the top of the diagram (the diagram is not to scale).

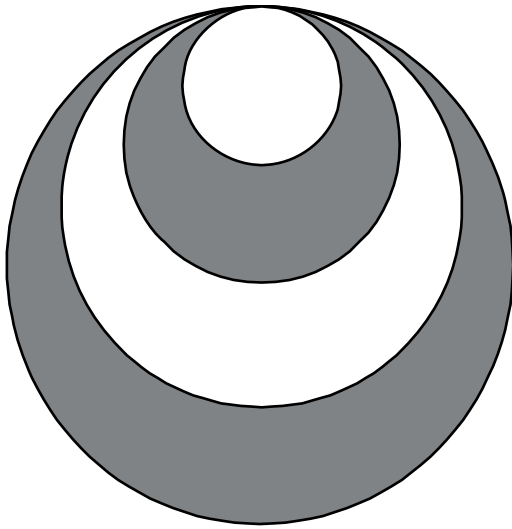

The diameter of the smallest circle is d , the second is $2d$, the third is $3d$ and the largest is $4d$.

Find an expression for the area of the shading in the design.

- A $\frac{5}{2}\pi d^2$
- B $4\pi d^2$
- C $\frac{1}{4}\pi d^2$
- D $10\pi d^2$
- E $\frac{3}{2}\pi d^2$

5 The diagrams below show part of the breathing apparatus of a human.

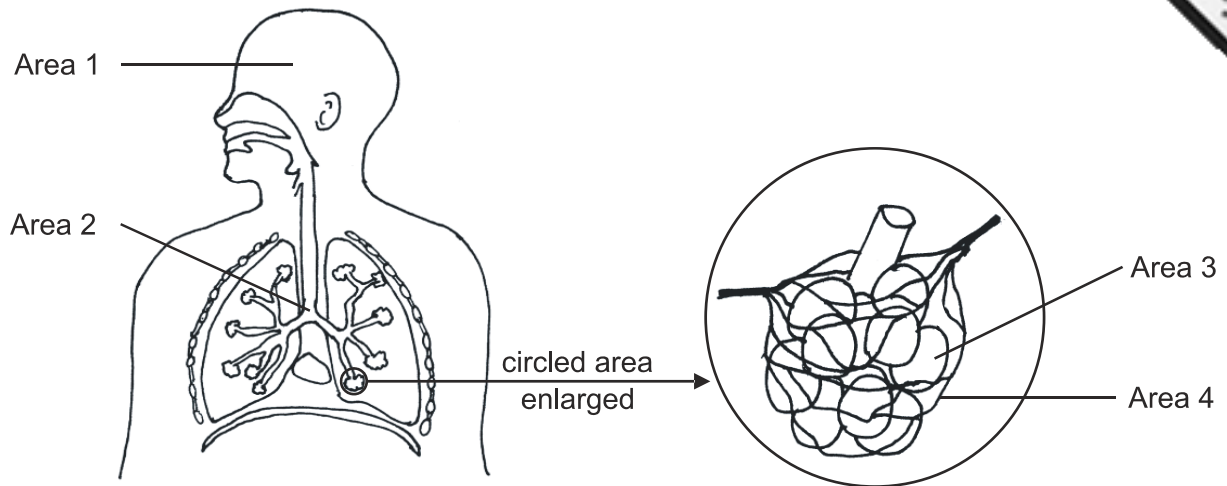

Which row of the table correctly identifies the locations affected by two chemicals found in cigarettes and by two diseases associated with smoking?

	Location affected			
	1	2	3	4
A	Carbon monoxide	Bronchitis	Nicotine	Emphysema
B	Nicotine	Bronchitis	Emphysema	Carbon monoxide
C	Carbon monoxide	Nicotine	Bronchitis	Emphysema
D	Nicotine	Emphysema	Bronchitis	Carbon monoxide
E	Bronchitis	Carbon monoxide	Emphysema	Nicotine
F	Bronchitis	Emphysema	Carbon monoxide	Nicotine

- 6 The diagram represents the molecule lecithin, a chemical that is added to chocolate drinks to prevent the oils separating out from water.

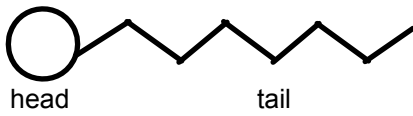

Which row of the table below correctly identifies the characteristics of the molecule?

	Head	Tail
A	hydrophobic	hydrophobic
B	hydrophobic	hydrophilic
C	hydrophilic	hydrophobic
D	hydrophilic	hydrophilic
E	neither hydrophobic nor hydrophilic	hydrophilic
F	hydrophilic	neither hydrophobic nor hydrophilic

- 7 Students investigate a radioactive source. They place a detector close to a radioactive source and take 5 readings over 5 minutes. They then place a thin sheet of paper between the detector and the source, and again observe the counts over 5 minutes. Lastly they replace the paper sheet with an aluminium one and observe the counts over 5 minutes. Their results are shown below:

	Nothing	Paper	Aluminium
Reading 1	100	101	30
Reading 2	98	102	31
Reading 3	99	96	28
Reading 4	103	101	33
Reading 5	101	103	27

What type(s) of radiation is being given off by the source?

- A** α only
- B** β only
- C** γ only
- D** α and β
- E** α and γ
- F** β and γ

- 8 A formula which connects the 'going', G , with the 'rise', R , of stairs in a staircase is below.

$$G = 5 + \sqrt{7(9 - R)^2 + 9}$$

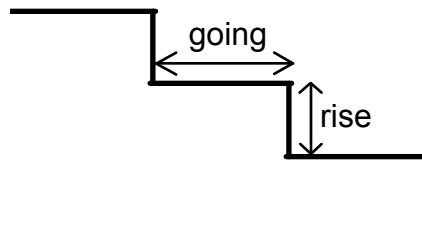

Rearrange the formula to give R in terms of G .

A $R = 9 - \sqrt{\frac{(G-5)^2 + 9}{7}}$

B $R = 9 - \frac{G-8}{\sqrt{7}}$

C $R = 9 + \sqrt{\frac{(G-5)^2 - 9}{7}}$

D $R = 9 + \frac{G-8}{\sqrt{7}}$

E $R = 9 - \sqrt{\frac{(G-5)^2 - 9}{7}}$

- 9 In one type of neurological disease, neurons are unable to detect a certain stimulus which would normally cause pain. In a patient with this disease, which of the following would be true?
- 1 The patient would not show a reflex action to the stimulus.
 - 2 The patient would be able to take appropriate action if they could also see the application of the stimulus.
 - 3 The patient would be able to sense pain but would not be able to respond to it.
 - 4 The patient would be able to sense pain but would not be able to communicate this to the brain.
- A** 1 and 2 only
- B** 1 and 3 only
- C** 1 and 4 only
- D** all of the statements

- 10 Inorganic builders are put into detergents to act as a buffer, i.e. to keep the pH close to 10. Sodium tripolyphosphate is a major one used. The equation for its formation is shown below.

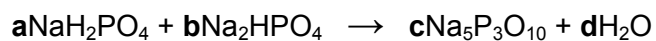

What are the values of **a**, **b**, **c** and **d**?

- A 3, 1, 1, 3
- B 6, 2, 2, 7
- C 2, 4, 2, 2
- D 1, 2, 1, 2
- E 2, 2, 1, 2

- 11 The diagrams show, not to scale, three different situations in which a force F acts. Also, in each case is a distance d .

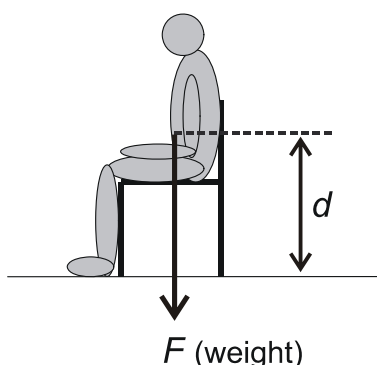

Diagram 1:
Person sitting on a chair

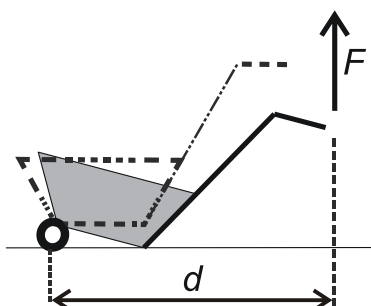

Diagram 2:
Wheelbarrow being lifted

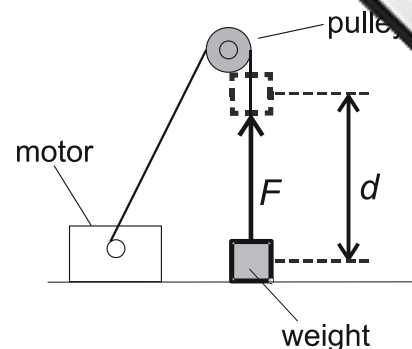

Diagram 3:
Weight being lifted by a motor

Which line in the table shows whether or not work is being done by force F in each situation and, if so, whether the work done is equal to $F \times d$?

	Work being done by force F ?	Work done = $F \times d$?
A	only in diagrams 1 and 2	only in diagram 1
B	only in diagrams 1 and 2	only in diagram 2
C	only in diagrams 2 and 3	only in diagram 2
D	only in diagrams 2 and 3	only in diagram 3
E	in diagrams 1, 2 and 3	only in diagrams 1 and 2
F	in diagrams 1, 2 and 3	only in diagrams 2 and 3
G	only in diagrams 1 and 3	only in diagram 1
H	only in diagrams 1 and 3	only in diagram 3

12 Evaluate:

$$\sqrt[3]{\frac{2 \times 10^5}{(5 \times 10^{-3})^2}} - \sqrt{(4 \times 10^3) - (4 \times 10^2)}$$

- A -6.2
- B $160 - 20\sqrt{5}$
- C 140
- D $240 - 20\sqrt{5}$
- E 1940

- 13 The left diagram shows a plate containing a jelly with one species of bacterium evenly through it. Placed on the jelly are three discs called P, Q and R. They have been treated as shown in the key.

The right diagram shows the plate 48 hours later.

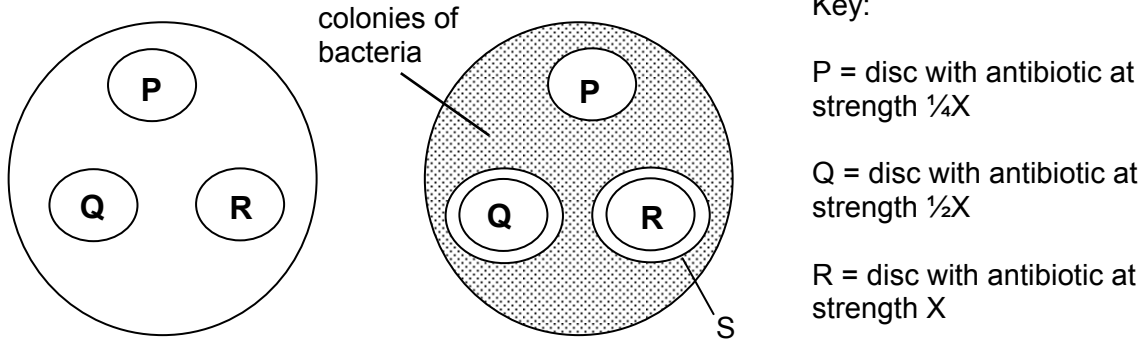

Which of the following is/are possible explanations for the result?

- 1 Antibiotic at strengths X and $\frac{1}{2}X$ are equally as effective.
 - 2 Bacterial resistance to this antibiotic occurs at all three strengths.
 - 3 S may represent the maximum distance the antibiotic has diffused out of the disc.
- A 1 only
- B 2 only
- C 3 only
- D 1 and 2 only
- E 1 and 3 only
- F 2 and 3 only
- G 1, 2 and 3
- H none of these

- 14 Azurite is a mineral made up of a mixture of CuCO_3 and $\text{Cu}(\text{OH})_2$.

Which one of the following is a possible formula of azurite?

- A $\text{Cu}_3\text{CH}_4\text{O}_4$
 B $\text{Cu}_3\text{CH}_4\text{O}_5$
 C $\text{Cu}_3\text{CH}_4\text{O}_6$
 D $\text{Cu}_3\text{C}_2\text{H}_2\text{O}_6$
 E $\text{Cu}_3\text{C}_2\text{H}_2\text{O}_7$
 F $\text{Cu}_3\text{C}_2\text{H}_2\text{O}_8$

- 15 The microwaves generated in a microwave oven travel through air at a speed of $3.0 \times 10^8 \text{ m/s}$, with a wavelength of 12cm. They pass through plastic food containers, but at a reduced speed of $2.0 \times 10^8 \text{ m/s}$.

What are the wavelength and frequency of these microwaves as they pass through a plastic food container?

	Wavelength (cm)	Frequency (Hz)
A	8	1.7×10^9
B	8	2.5×10^9
C	8	3.8×10^9
D	12	1.7×10^9
E	12	3.8×10^9
F	18	1.7×10^9
G	18	2.5×10^9
H	18	3.8×10^9

16 In the triangle ABC shown below (not to scale):

$$\tan A = \frac{1}{6} \text{ and } \tan B = \frac{2}{3}$$

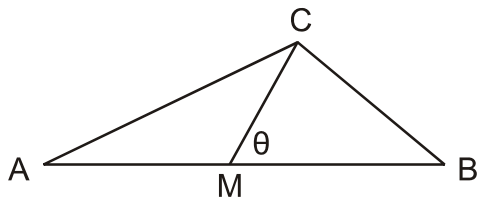

M is the midpoint of AB.

What is the value of $\tan \theta$

- A $\frac{1}{9}$
- B $\frac{5}{12}$
- C $\frac{4}{9}$
- D $\frac{1}{2}$
- E $\frac{5}{6}$

- 17 Consumption of alcohol leads to an increase in dilute urine production by reducing the the hormone ADH.

Which of the following are correct statements about alcohol and/or ADH?

- 1 ADH travels in the bloodstream.
- 2 There is a positive correlation between the level of ADH and the production of dilute urine.
- 3 Increased ADH leads to increased formation of dilute urine.
- 4 A reduced level of ADH could lead to dehydration.

- A 1 and 2 only
- B 1 and 3 only
- C 1 and 4 only
- D 2 and 3 only
- E 2 and 4 only
- F 3 and 4 only

- 18 Vanadium is a metal that lies just above zinc in the reactivity series.

Which one of the following could **not** be used to obtain the metal from its ore?

- A electrolysis of the molten chloride
- B heating of the chloride with metallic sodium
- C heating the oxide with metallic aluminium
- D treating a solution of vanadium sulfate with metallic iron
- E treating a solution of vanadium chloride with metallic magnesium

- 19 The circuit shows three lamps and two ammeters in a circuit.

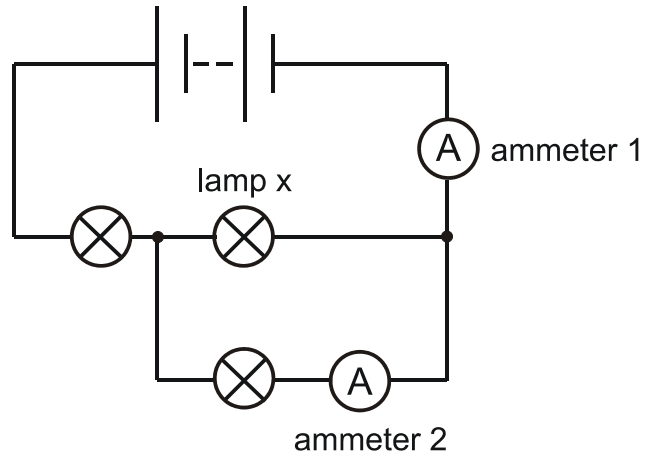

Lamp X 'blows' (the filament breaks).

What happens to the reading on each ammeter, and to the total resistance of the circuit?

	Reading on ammeter 1	Reading on ammeter 2	Total resistance of circuit
A	decreases	decreases	decreases
B	decreases	decreases	increases
C	decreases	increases	decreases
D	decreases	increases	increases
E	increases	decreases	decreases
F	increases	decreases	increases
G	increases	increases	decreases
H	increases	increases	increases

- 20 In a fairground game there are two bags, each of which contains 4 coloured balls. The first bag contains 2 red balls, 2 yellow balls and 1 blue ball. The second bag contains a total of 4 red balls, 3 yellow balls and 1 blue ball. The player chooses one of the bags and removes two balls without replacing them. If the two balls are the same colour then the player wins. The player is equally likely to choose either bag and the balls are arranged to give the smallest possible probability for the player to win.

What is the probability that the player wins?

- A $1/6$
- B $1/4$
- C $9/24$
- D $1/2$
- E $3/4$

- 21 In a monohybrid genetic cross a ratio of phenotypes of 3:0 rather than the usual 3:1 ratio was seen. This could be due to:

- 1 offspring with both dominant alleles not surviving.
- 2 only a small number of offspring being produced.
- 3 chance.

- A 1 only
- B 2 only
- C 1 and 2 only
- D 2 and 3 only
- E 1, 2 and 3

- 22 Tritium, symbol T, is hydrogen with a mass number of 3. It is radioactive and undergoes β decay.

Which of the following could be the only product(s) after a quantity of HTO undergoes decay?

- 1 HeOH
 - 2 H₂O, O₂ and He
 - 3 H₂O, H₂ and He
-
- A 1 only
 - B 2 only
 - C 3 only
 - D 1 and 2 only
 - E 1 and 3 only
 - F 2 and 3 only

- 23 A cyclist and a bike have a combined mass of 100kg. The cyclist free-wheels (rolls without pedalling) at a constant speed of 0.8m/s down a 1 in 10 slope (this means that the cyclist descends 1.0m for each 10m travelled along the road, as shown in the diagram.)

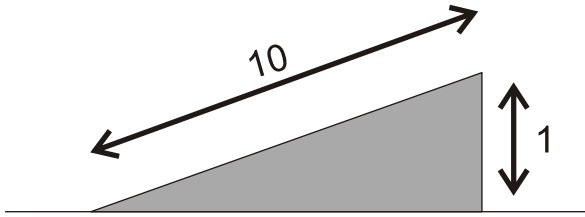

Calculate the loss in gravitational potential energy as he loses 100m in vertical height and hence calculate the total resistive force on the cyclist.
[g = 10N/kg]

	Loss in gravitational potential energy (J)	Resistive force (N)
A	3200	3.2
B	3200	$32/\sqrt{99}$
C	3200	$32/\sqrt{100}$
D	100 000	100
E	100 000	$1000/\sqrt{99}$
F	100 000	$1000/\sqrt{101}$

- 24 The new sign for a local business contains two different sections. One of the sections will be produced from wood, while the other will be metal. Metal is three times as expensive as wood. The cost of metal needed for each sign is proportional to the diameter of the sign, while the cost of wood needed is proportional to the square of the diameter. If the diameter of the sign is doubled, then the total cost of the materials will be tripled.

What percentage (to the nearest 1%) of the sign is metal?

- A 25%
- B 33%
- C 50%
- D 67%
- E 75%

- 25 What is the minimum number of people shown in the family pedigree who **must** be heterozygous for the two situations described in the table in the absence of any new m

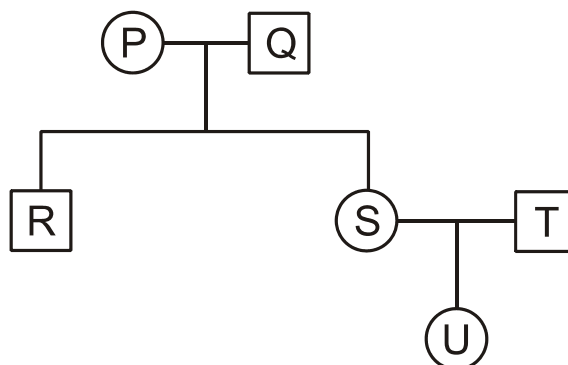

	Only U shows a recessive condition	Only R and U show a recessive condition
A	1	1
B	1	2
C	2	3
D	2	4
E	3	4
F	3	5
G	4	5

- 26 A mixture of $C_2H_4(g)$ and $H_2(g)$ is placed in a sealed container. Some finely divided nickel is added as a catalyst to the mixture. The temperature rises to $150^\circ C$ and the two gases slowly react to give $C_2H_6(g)$.

Which row of the table correctly identifies how the pressure changes after the nickel is added?

	Initially	During the course of the reaction
A	stays the same	stays the same
B	stays the same	decreases
C	stays the same	increases
D	increases	stays the same
E	increases	decreases
F	increases	increases

- 27 A sound wave is produced by a loudspeaker cone, which creates pulses of pressure by moving back and forth between two points X and Y as shown in the diagram.

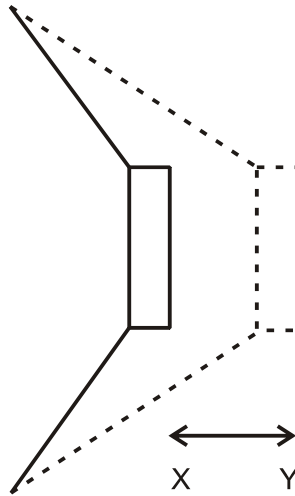

The distance between points X and Y is 5.0mm and the loudspeaker produces pulses of pressure every 0.2 milliseconds.

The following statements about the sound wave produced are made:

- P** It has a speed of 25m/s
- Q** It has an amplitude of 5.0mm
- R** It has a wavelength of 5.5mm
- S** It has a fundamental frequency of 5.0kHz

Which of these statements can be correctly deduced from the information given?

- A** P only
- B** P and Q only
- C** P and R only
- D** P, R and S only
- E** Q and S only
- F** R and S only
- G** S only

BLANK PAGE

BLANK PAGE