

BioMedical Admissions Test**4500/12**

Wednesday 3 November 2010

Morning

30 minutes

SECTION 2 Scientific Knowledge and Applications**Instructions to Candidates**

Please read this page carefully, but do not open the question paper until you are told that you may do so.

A separate answer sheet is provided for this section. Please check you have one. You also require a soft pencil and an eraser.

Please complete the answer sheet with your BMAT candidate number, centre number, date of birth and name.

Speed as well as accuracy is important in this section. **Work quickly, or you may not finish the paper.** There are no penalties for incorrect responses, only points for correct answers, so you should attempt all 27 questions. All questions are worth one mark.

Answer on the sheet provided. Most questions ask you to show your choice between options by shading a circle. If questions ask you to write in words or numbers, be sure to write clearly in the spaces provided. If you make a mistake, erase thoroughly and try again.

Any rough work should be done on this question paper.

Dictionaries and calculators may NOT be used.

Please wait to be told you may begin before turning this page.

This paper consists of 21 printed pages and 3 blank pages.

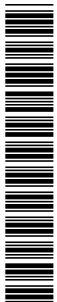

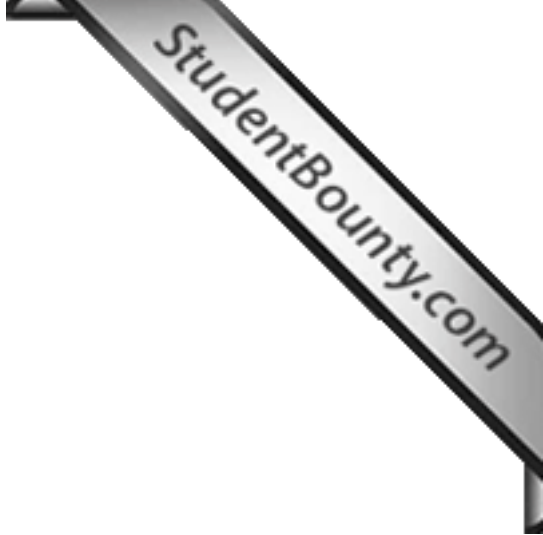

BLANK PAGE

- 1 Which row of the table correctly describes what happens when body temperature rises in a human?

	temperature change detected by	arterioles (small arteries)	hair erector muscles	capillaries in the skin
A	cerebral cortex	dilate	relax	move nearer skin surface
B	cerebral cortex	constrict	contract	move away from skin surface
C	cerebral cortex	dilate	contract	do not move
D	hypothalamus	constrict	relax	move away from skin surface
E	hypothalamus	dilate	relax	do not move
F	hypothalamus	constrict	contract	move nearer skin surface

- 2 A compound of iodine and oxygen contains 63.5g of iodine and 20.0g of oxygen.

Which of the following would be its formula?

(A_r : I = 127; O = 16)

- A** IO
- B** IO₂
- C** I₂O
- D** I₂O₃
- E** I₂O₅
- F** I₅O₂

- 3 In a laboratory experiment, protactinium-234 undergoes radioactive decay by β -emission to form uranium-234.

The table below describes how the mass of uranium-234 present in the sample varies with time from the start of the experiment:

time / min	mass of u-234 / mg
0.0	0.0
1.2	8.0
2.4	12.0
3.6	14.0
4.8	15.0
6.0	15.5
7.2	15.7
8.4	15.9
9.6	15.9
10.8	16.0
12.0	16.0

Using the information in the table, approximately what is the half-life of protactinium-234?

- A 1.2 minutes
- B 2.4 minutes
- C 6.0 minutes
- D 9.6 minutes
- E 10.8 minutes
- F 12.0 minutes
- 4 I have two containers with different capacities. Initially, the larger one is full of water and the smaller one is empty. I pour water from the larger container into the smaller container until they contain the same volume of water. The volume of water in the large container is now p times its capacity and the volume of water in the small container is q times its capacity.

Which one of the following statements about p and q must be true?

- A $p + q = 1$ (but p and q are not necessarily both 0.5)
- B $p = 0.5$ and $q = 0.5$
- C $p = 0.5$ and $q > 0.5$
- D $p > 0.5$ and $q = 0.5$
- E $p > 0.5$ and $q > 0.5$

5 The following statements are about hormone levels and their effect:

- 1 Increasing levels of insulin cause an increase in blood glucose levels.
- 2 Increasing levels of oestrogen increases the thickness of the inner lining of the uterus.
- 3 Increasing levels of adrenaline increases the heart rate.

Which of the statements are true?

- A 1 and 2
- B 1 and 3
- C 2 and 3
- D all of the above
- E none of the above

6 Carbon, in the form of coke, is used to reduce iron oxide in a blast furnace. The three stages are shown below:

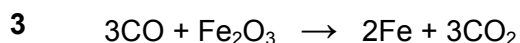
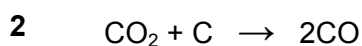
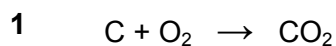

If 12g of carbon is used in stage 2 and all the carbon monoxide produced is used in stage 3, what mass of carbon dioxide is produced in stage 3?

(A_r : C = 12; O = 16)

- A 17.8g
- B 35.6g
- C 44g
- D 88g
- E 132g

- 7 The depth of water in a particular tidal harbour varies with time as shown in the graph.

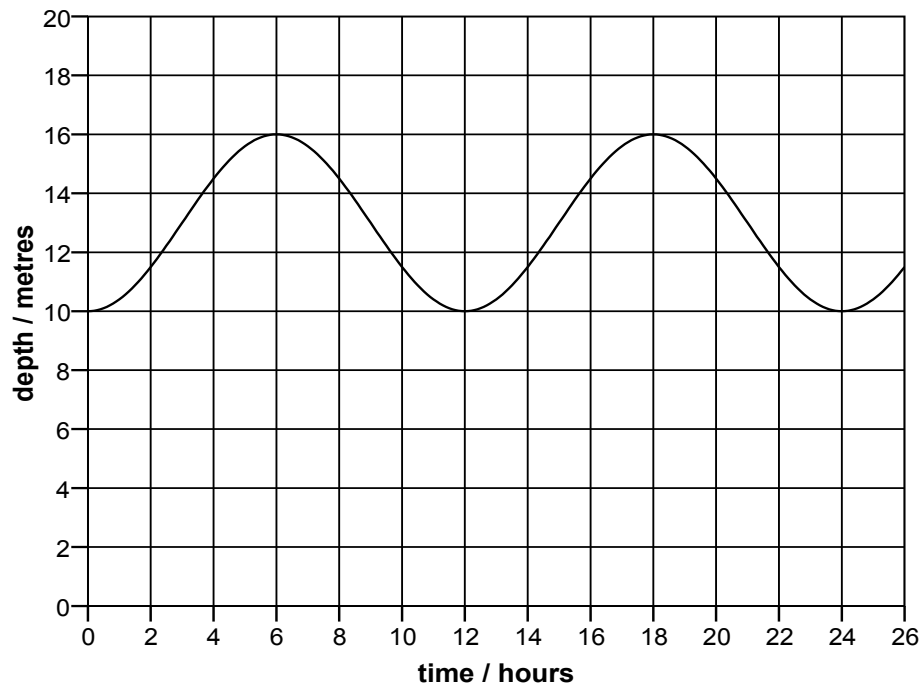

If the variation in depth caused by the effect of the tide is considered as a wave, what are the amplitude and frequency of this wave?

	amplitude / metres	frequency / hertz
A	3	$1/(12 \times 3600)$
B	3	$3600/12$
C	6	$1/(24 \times 3600)$
D	6	$3600/24$
E	8	$1/(12 \times 3600)$
F	8	$3600/12$
G	16	$1/(24 \times 3600)$
H	16	$3600/24$

- 8 A children's game is played on a square grid starting in the centre. Players spin two spinners to decide how to move their counters. The first spinner decides the direction (Left, Right, Up, Down) and the second spinner decides the distance (1, 2, 3 or 4 squares).

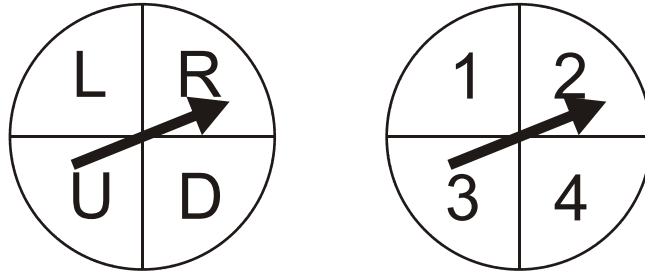

What are the chances that, after two moves, a player is exactly back where they started?

- A $1/256$
- B $1/64$
- C $1/16$
- D $1/8$
- E $1/4$
- 9 Which one of the following correctly completes the statement:
- During the process of evolution, natural selection will favour individuals with...
- A an advantageous gene pool.
- B an advantageous allele.
- C a high reproductive capacity.
- D a wide geographic distribution.
- E a narrow geographic distribution.

10 Which two of the following are produced by the complete combustion of fuels?

1 CH₄

2 CO

3 CO₂

4 H₂O

5 He

6 NH₃

A 1 and 3

B 2 and 4

C 2 and 6

D 3 and 4

E 3 and 6

F 4 and 5

- 11 When radioactive isotopes decay, they sometimes have to go through a succession of disintegrations to reach a stable isotope. These are called decay chains, and involve the successive emission of numerous α and/or β particles.

One such isotope is radon-219 (${}^{219}_{86}\text{Rn}$), which goes through a chain in which three α particles and two β particles are emitted before reaching a stable isotope.

What are the atomic and mass numbers of the resulting stable isotope?

	atomic number	mass number
A	80	207
B	80	211
C	82	207
D	82	215
E	85	211
F	85	219
G	86	215
H	86	219

- 12 The mean time for running a race by a group of 20 people was 54 seconds. The times for a second group of people were added and the value of the mean went up to 56 seconds.

Which formula represents the relationship between the number of people in the second group, P , and the mean time of the second group, T ?

A $P = \frac{40}{T - 54}$

B $P = \frac{1080}{T - 54}$

C $P = \frac{40}{T - 56}$

D $P = \frac{1080}{T - 56}$

E $P = \frac{1120}{T} - 20$

- 13 Signals are transmitted from one neuron to the next neuron, by molecules. These statements are about this process:
- 1 Transmitter molecules are formed in the receptors.
 - 2 The signal is transmitted across the synapse by osmosis.
 - 3 Transmitter molecules are released once the signal has been transmitted across the synapse.
 - 4 The release of transmitter molecules is triggered by an impulse.
 - 5 The signal is transmitted across the synapse by diffusion.

Which of the above statements are correct?

- A 1 and 2
- B 1 and 3
- C 1 and 5
- D 2 and 4
- E 3 and 4
- F 4 and 5

14 Which of the following ionic equations are correct?

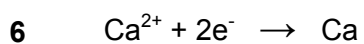
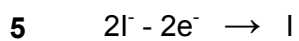
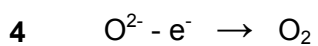
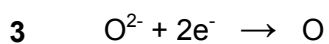
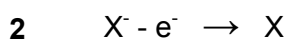
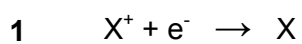

A 1, 2 and 6

B 1, 3 and 5

C 1, 4 and 5

D 2, 3 and 6

E 2, 4 and 5

F 3, 4 and 6

- 15 The circuit shows five identical filament bulbs designed to work at 12V connected in a circuit with two switches. Switch P is initially open and switch Q is initially closed.

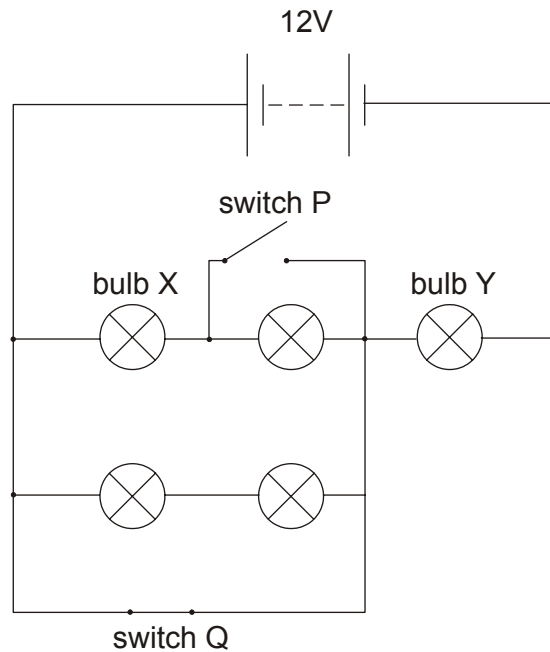

Switch P is then closed and switch Q is opened.

Compared with their brightness before these changes were made, how has the brightness of bulbs X and Y changed?

	bulb X	bulb Y
A	brighter	brighter
B	brighter	dimmer
C	dimmer	brighter
D	dimmer	dimmer
E	unchanged	brighter
F	brighter	unchanged

- 16 A shape is formed by drawing a triangle ABC inside the triangle ADE. BC is parallel to DE.

$$AB = 4\text{cm} \quad BC = x\text{cm} \quad DE = x + 3\text{cm} \quad DB = x - 4\text{cm}$$

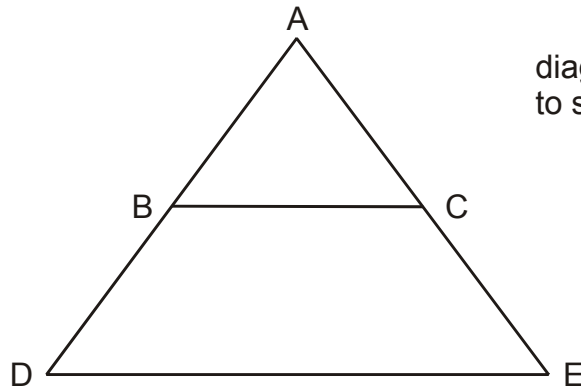
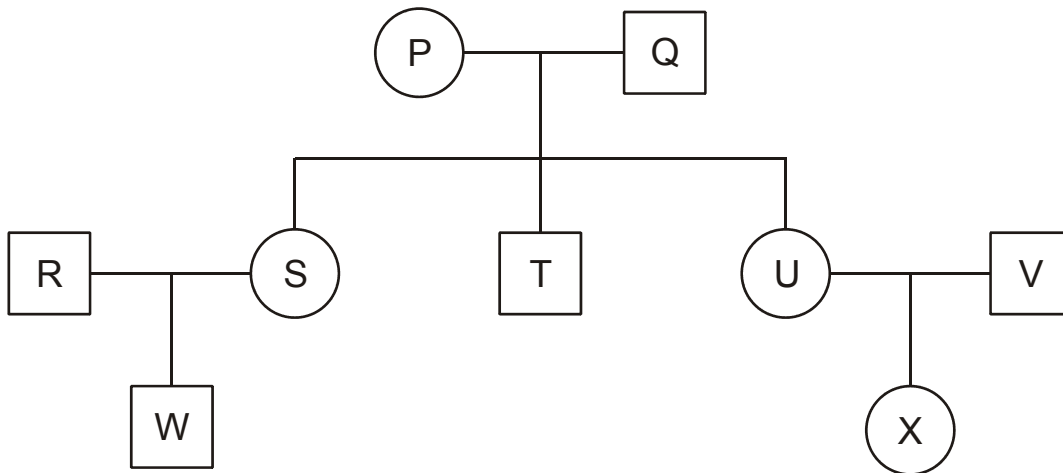

diagram not
to scale

Calculate the length of DE.

- A 5cm
- B 7cm
- C 9cm
- D $4 + 2\sqrt{7}$ cm
- E $7 + 2\sqrt{7}$ cm

- 17 In the family tree shown below, both P and Q are carriers of a recessive allele which causes a condition. Only individuals R and X have the condition.



What is the percentage likelihood of S, T and U each being a carrier?

	Percentage likelihood of being a carrier		
	S	T	U
A	25	25	50
B	25	25	100
C	25	50	100
D	50	50	50
E	50	50	100
F	100	50	50
G	100	100	50

18 Magnesium hydrogen phosphate contains the following ions: Mg^{2+} , H^+ and PO_4^{3-} .

Which one of the following is a possible formula for magnesium hydrogen phosphate?

- A $\text{Mg}(\text{HPO}_4)_2$
- B $\text{Mg}(\text{H}_2\text{PO}_4)_2$
- C MgH_3PO_4
- D $\text{Mg}(\text{H}_3\text{PO}_4)_2$
- E Mg_2HPO_4
- F $\text{Mg}_2\text{H}_2\text{PO}_4$

- 19 The diagrams below show velocity-time or distance-time graphs for 4 different objects and S.

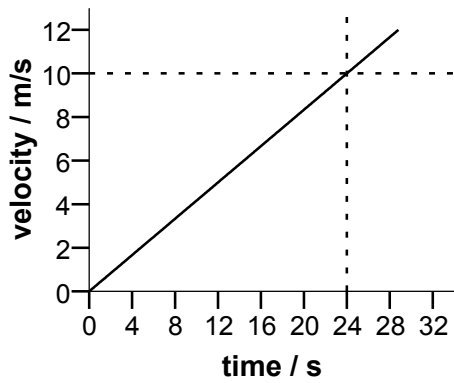

P

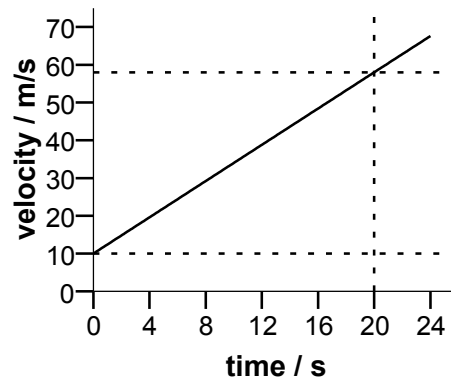

Q

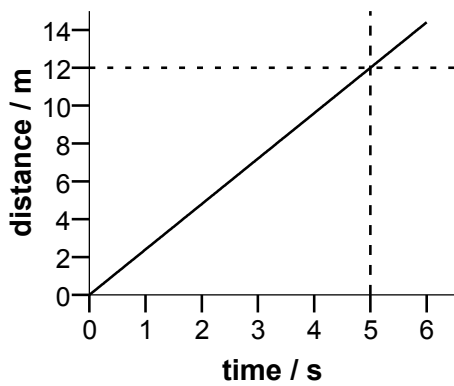

R

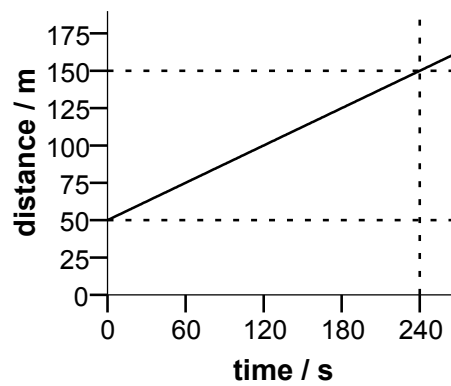

S

Which graph(s) show an object accelerating at 2.4m/s^2 ?

- A P only
- B Q only
- C R only
- D S only
- E P and Q
- F Q and R
- G P and S

- 20 The total surface area of a cylinder is numerically the same as its volume. The radius of the cylinder is r cm, the height is h cm.

Express h in terms of r .

A $h = \frac{2r}{r-2}$

B $h = \frac{2r}{r+2}$

C $h = r + 2$

D $h = r - 2$

E $h = 2r(r-2)$

- 21 The following statements are about nuclear division by meiosis and mitosis.

- 1 In animals meiosis only occurs in the reproductive organs.
- 2 Mitosis can result in the formation of clones.
- 3 Meiosis results in two nuclei.
- 4 Mitosis results in four nuclei.
- 5 Meiosis does not occur during asexual reproduction.

Which of these statements are true?

A 1, 2 and 3

B 1, 2 and 5

C 1, 3 and 4

D 2, 4 and 5

E 3, 4 and 5

- 22 A student prepared nitrobenzene by the following reaction.

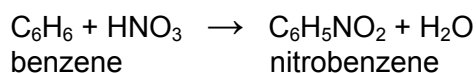

Starting with 3.9g of benzene, the student obtained 3.69g of nitrobenzene.

What is the percentage yield?

(A_r : H = 1; C = 12; N = 14; O = 16)

- A** 11%
- B** 53%
- C** 60%
- D** 95%
- 23 In an ornamental fountain, water is squirted vertically upwards through a nozzle by a pump. 5kg of water pass through the nozzle each second, and the water reaches a height of 5m after leaving the nozzle.

What is the power of the pump (assuming 100% efficiency), and at what speed does the water leave the nozzle?

(Take g to be 10N/kg)

	power of pump / W	speed of water / m/s
A	5	5
B	5	50
C	25	10
D	25	100
E	50	5
F	50	50
G	250	10
H	250	100

- 24 A design is set up by joining the points which are one third of the way along the sides of a square. This forms a second square as shown.

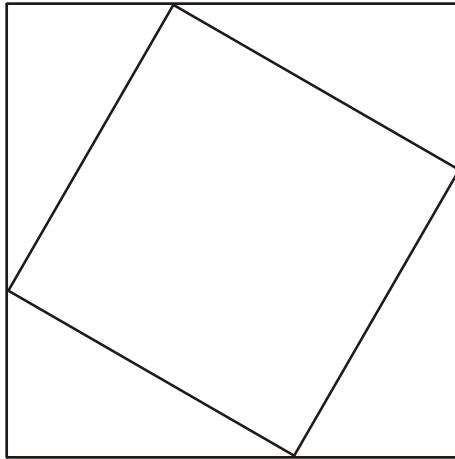

This process is repeated.

Calculate the area of the fourth square as a fraction of the original square.

- A $\frac{1}{27}$
- B $\frac{5\sqrt{5}}{81}$
- C $\frac{125}{729}$
- D $\frac{25}{81}$
- E $\frac{5\sqrt{5}}{27}$

- 25** The hormonal and nervous systems are often compared because of their similar roles in the body.

Which of the following statements about the two systems are true?

- 1** The nervous system relies only on electrical impulses to work.
 - 2** Both the hormonal and nervous systems activate target structures.
 - 3** The fastest responses in the body are produced by the nervous system.
 - 4** Only the hormonal system relies on the activity of chemicals.
 - 5** Parts of the hormonal system may be controlled by the central nervous system.
-
- A** 1, 2 and 3
 - B** 1, 2 and 4
 - C** 1, 2 and 5
 - D** 2, 3 and 4
 - E** 2, 3 and 5
 - F** 3, 4 and 5

21

26 Cyclohexene, C_6H_{10} , is drawn as:

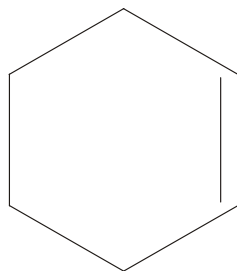

Apply this information for the steroid-type structure shown below to find the total number of carbon atoms in the molecule.

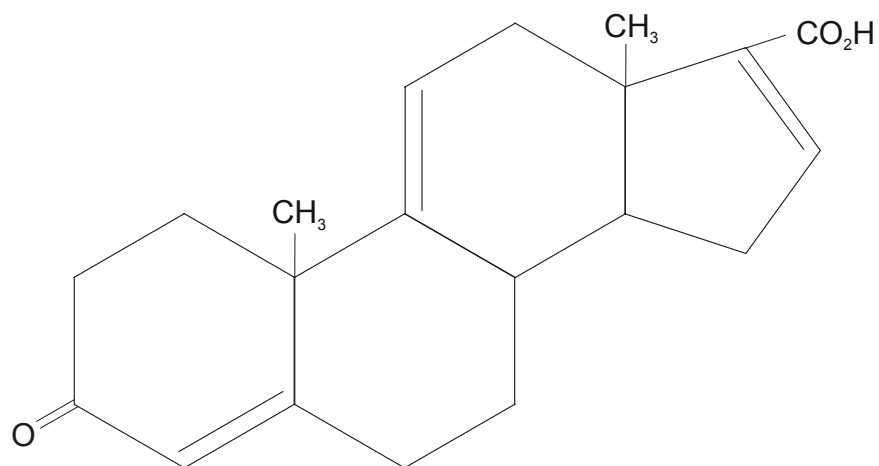

- A 17
- B 20
- C 21
- D 22
- E 26
- F 27

- 27 A car of mass 800kg moves up an incline of 1 in 20 (1 in 20 means for every 20m along the incline the car gains 1m in height) at a constant speed of 20m/s. The frictional force opposing the motion is 500N.

How much work has been done by the engine after the car has moved 50m?

- A 20kJ
- B 25kJ
- C 27kJ
- D 45kJ
- E 65kJ
- F 160kJ

END OF TEST

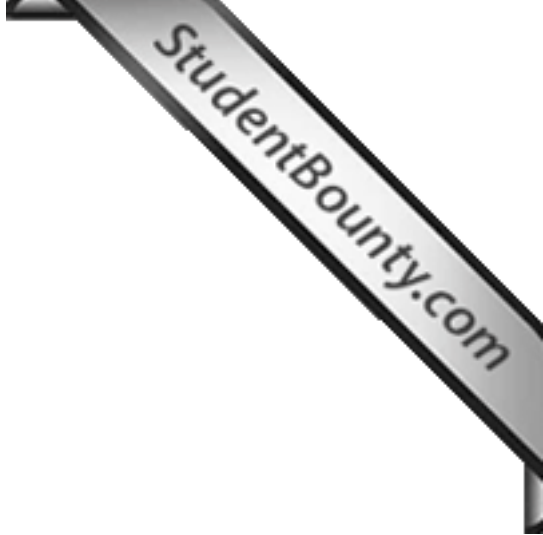

BLANK PAGE

BLANK PAGE

Disclaimer

The opinions expressed in this paper are not to be taken as the opinions of the University of Cambridge Local Examinations Syndicate (UCLES) or any of its subsidiaries.

Permission to reproduce items where third-party owned material protected by copyright is included has been sought and cleared where possible. Every reasonable effort has been made to trace copyright holders, but if any items requiring clearance have unwittingly been included, UCLES will be pleased to make amends at the earliest possible opportunity.