

AGA KHAN UNIVERSITY EXAMINATION BOARD

HIGHER SECONDARY SCHOOL CERTIFICATE

CLASS XII EXAMINATION

MAY 2012

Physics Paper II

Time allowed: 2 hours 20 minutes Marks 55

INSTRUCTIONS

Please read the following instructions carefully.

1. Check your name and school information. Sign that it is correct.

**I agree that this is my name and school.
Candidate's signature**

2. RUBRIC. There are THIRTEEN questions. Answer ALL THIRTEEN questions. Questions 11, 12 & 13 each offers TWO choices. Attempt any ONE choice from each.
3. When answering the questions:

Read each question carefully.
Use a black pencil for diagrams. DO NOT use coloured pencils.
DO NOT use staples, paper clips, glue, correcting fluid or ink erasers.
Complete your answer in the allocated space only. DO NOT write outside the answer box.
4. The marks for the questions are shown in brackets ().
5. You may use a scientific calculator if you wish.

Q.1. (Total 3 Marks)

The diagram represents a parallel plate capacitor with a dielectric inserted between its plates.

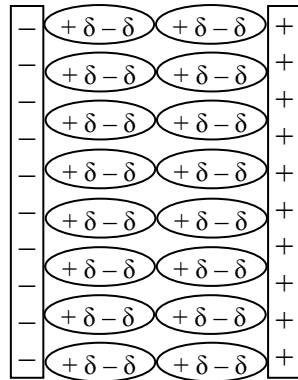

Define electric dipole. How can molecules of dielectric get polarized?

Q.2.

(Total 4 Marks)

The given diagram shows a source of emf ϵ of internal resistance r , connected to an external resistor of resistance R .

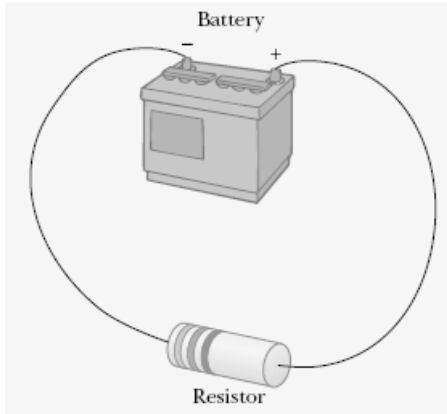

Show that the power P delivered to the load resistance R is $P = \frac{\epsilon^2 R}{(R + r)^2}$.

PLEASE TURN OVER THE PAGE

Q.3.

(Total 5 Marks)

Derive an equation for a force on a moving charge in a uniform magnetic field.

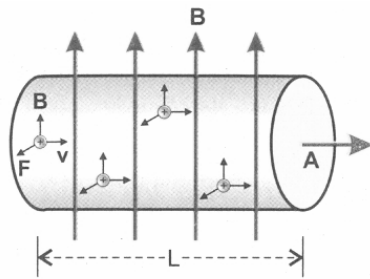

Q.4.

(Total 5 Marks)

Identify the given phenomenon and explain how we can get its mathematical formula.

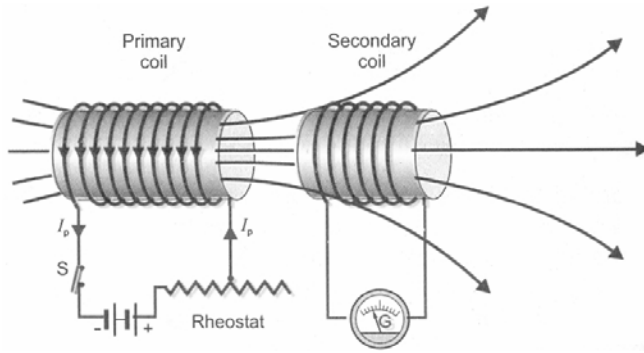

PLEASE TURN OVER THE PAGE

Q.5.

(Total 5 Marks)

Describe the construction, principle, working and any TWO advantages of a three phase A.C supply.

Q.6.

(Total 3 Marks)

Define the following solids:

i. Crystalline

ii. Amorphous

iii. Polymeric

PLEASE TURN OVER THE PAGE

Q.7.

(Total 3 Marks)

What is an analogue system? Give TWO examples of it.

Q.8.

(Total 3 Marks)

Determine the speed of a proton if its mass becomes three times of its real mass which is $1.67 \times 10^{-27} \text{ kg}$.

PLEASE TURN OVER THE PAGE

Q.9.

(Total 4 Marks)

The diagram represents a hydrogen atom emitting a photon of light during its transition from level 2 to level 1.

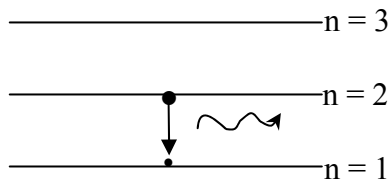

Calculate the wavelength and frequency of the emitted photon, where

$$c = 3 \times 10^8 \text{ m/s}, R_H = 1.09 \times 10^7 \text{ m}^{-1}.$$

Q.10.

(Total 5 Marks)

$^{238}_{92}\text{U}$ decays by emitting the following particles in series before reaching a stable form.

$\alpha, \beta, \beta, \alpha, \alpha, \alpha, \alpha, \alpha, \beta, \beta, \alpha, \beta, \beta, \alpha$

Find the atomic and mass number of the final nucleus.

Q.11.

(Total 5 Marks)

EITHER

a. The diagram represents a combination of capacitors.

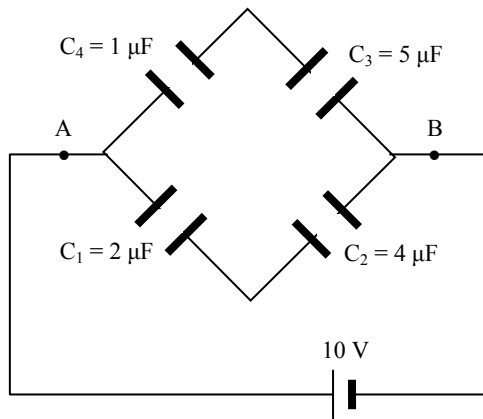

Calculate the effective capacitance between terminals A and B.

OR

b. Define Gaussian surface. Assume a spherical Gaussian surface surrounding a point charge q . Explain what happens to the total flux through the surface if:

- i. the charge is doubled;
- ii. the radius of the sphere is tripled;
- iii. the surface is changed to a cylinder;
- iv. the charge is moved to another location inside the surface.

Q.12.

(Total 5 Marks)

EITHER

a. The given diagram represents a magnet moving in and out of the coil at a constant speed without stopping.

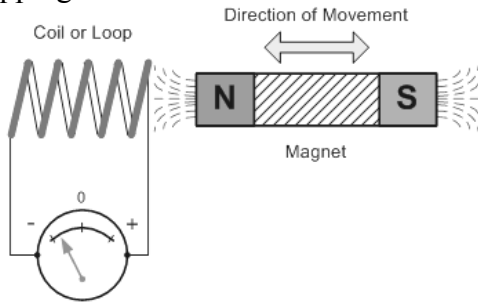

Discuss the phenomenon which comes into effect and state the law which governs it. Name any TWO devices which work on this phenomenon.

OR

b. Describe any FIVE differences between alternating and direct current generators.

Q.13.

(Total 5 Marks)

EITHER

- a. "Relativity teaches us the connection between the different descriptions of one and the same reality." (**Albert Einstein**)

Describe the special theory of relativity and explain its TWO postulates.

OR

- b. The photocell is one of the most important modern technological advancements allowing for a whole range of new technologies to be created.

Define photocells. Describe any THREE uses of photocells.

Please use this page for rough work

Please use this page for rough work