



Rewarding Learning

ADVANCED SUBSIDIARY (AS)
General Certificate of Education
2013

Technology and Design

Assessment Unit AS 1

assessing

Product Design and
Systems and Control

[AV111]



TUESDAY 4 JUNE, MORNING

TIME

2 hours.

INSTRUCTIONS TO CANDIDATES

Write your Centre Number and Candidate Number on the Answer Booklet provided and on the A3 pro forma answer page.

Answer **all eight** questions in Section A, and both questions in Section B **or** Section C **or** Section D.

An A3 pro forma is provided for Questions **12(b)(iv)** and **(v)**, **13(b)(i)** and **(ii)** and **14(d)(i)** and **(ii)**. At the conclusion of the examination, attach the A3 pro forma answer page securely to the Answer Booklet with the treasury tag supplied.

You are provided with an insert for use with Questions **7(ii)**, **13** and **14**.

Do **not** write your answer on this insert.

INFORMATION FOR CANDIDATES

The total mark for this paper is 80, including a maximum of 4 marks for quality of written communication.

Marks for quality of written communication will be awarded for Questions **7(ii)**, **9(b)(iii)**, **10(d)(ii)**, **11(a)(vi)**, **12(b)(vi)**, **13(a)(v)** and **14(c)**.

Figures in brackets printed down the right-hand side of pages indicate the marks awarded to each question or part question.

All questions do not carry equal weighting.



Section A

Product Design and Practice

Answer **all** questions in this section.

You are advised to spend approximately **1 hour** on this section.

- 1 Briefly explain what is meant by each of the following terms:
- Strength
 - Durability
 - Brittleness
 - Plasticity
- [4]
- 2 Plastic coating is one of a number of finishing processes used on metal products intended for outdoor use.
- (i) Briefly outline **two** main purposes of finishes which are used on metal products intended for outdoor use. [2]
- (ii) Briefly explain the process of plastic coating. [2]
- 3 (i) Briefly explain the difference between thermoplastic and thermosetting plastics. [2]
- (ii) Give **two** main reasons, other than cost and availability, why nylon is used for gearwheels. [2]
- (iii) Give **two** main reasons, other than cost and availability, why ABS is used for children's toys. [2]
- 4 Manhole covers can be manufactured by the process of sand casting.
- (i) Give **one** main reason why sand casting is a suitable process for the manufacture of this product. [1]
- (ii) With the aid of an annotated sketch describe the sand casting process. [4]

- 5 A report by a company manufacturing gym exercising equipment made reference to the following terms:
- Factor of safety
 - Statistical testing methods
 - British Standards
- (i) Briefly explain what is meant by the term factor of safety. [2]
- (ii) Give **one** main reason why the company would want to use statistical testing methods. [1]
- (iii) Give **one** main reason why the company would want to have their products comply with British Standards. [1]
- 6 (i) State what is meant by the term CIM. [1]
- (ii) Explain how CIM is used during the manufacturing stage of a product or component. [2]
- (iii) Explain how CIM is used during the assembly stage of a product. [2]
- 7 (i) Explain the difference between aesthetics and ergonomics. [2]
- (ii) With reference to the photograph on the insert of the suitcase, **Fig. 7**, outline how the designer has used form, texture and colour to create aesthetic appeal. [3]
- Quality of written communication [2]
- 8 By focusing on the 3Rs when creating sustainable products, designers can ensure that the impact on the environment is minimised.
- (i) Explain what is meant by the term sustainability when creating products. [2]
- (ii) With reference to products of your choice explain how each of the 3Rs are used to ensure that the impact on the environment is minimised. [3]

Section B

Electronic and Microelectronic Control Systems

Answer both questions in this section **or** both questions in Section C **or** both questions in Section D.

You are advised to spend approximately **1 hour** on this section.

- 9 (a) The circuit shown in **Fig. 9(a)** allows a capacitor to charge up through a resistor.

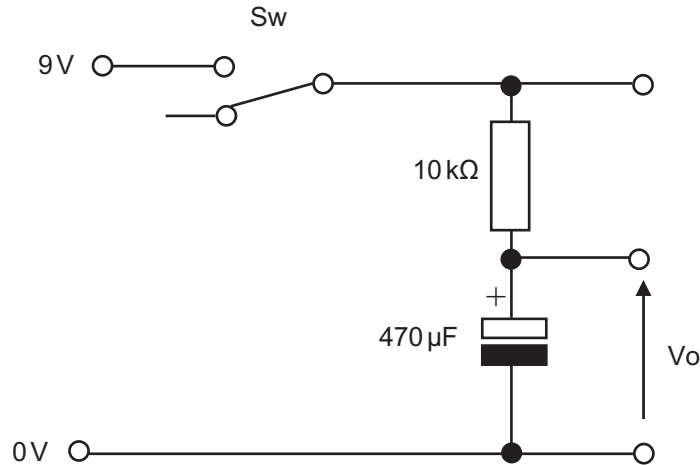

Fig. 9(a)

- (i) State the formula for time constant for the circuit shown in **Fig. 9(a)** and then calculate the time constant. [2]
- (ii) Sketch and label a graph showing the voltage V_o against time when **Sw** in **Fig. 9(a)** is switched to allow the initially discharged capacitor to fully charge. Indicate the time constant on the graph. [2]
- (iii) Explain with the aid of an annotated circuit diagram how the circuit shown in **Fig. 9(a)** could be modified (utilising the unused pole of the switch **Sw**) to enable the capacitor to discharge in approximately twice the time it takes to charge. [3]

(b) The circuit shown in **Fig. 9(b)** shows a transistor based circuit which utilises the resistor and capacitor from **Fig. 9(a)** in conjunction with a relay to control a motor.

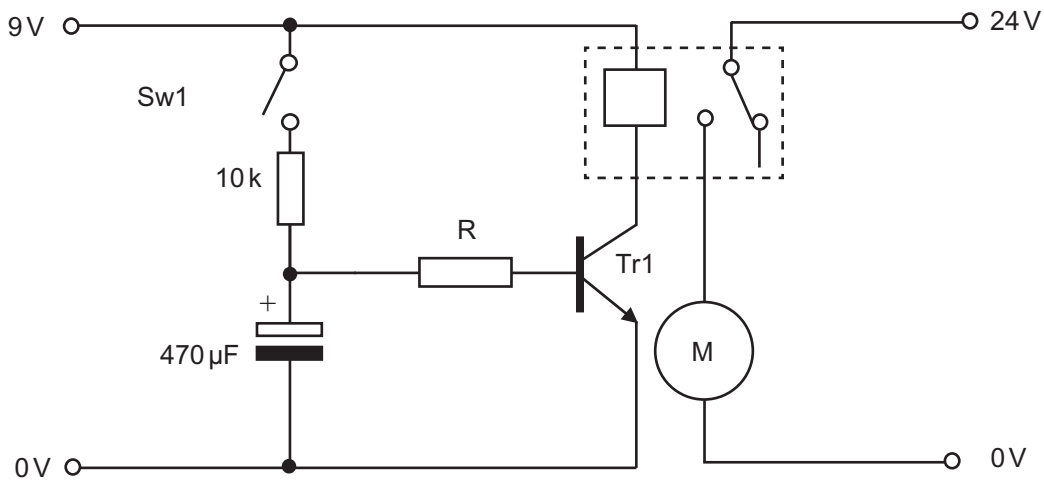

Fig. 9(b)

- (i) Calculate the minimum gain of the transistor Tr1 in **Fig. 9(b)** if the base current is 5 mA and the resistance of the relay coil is 20 ohms. [3]
- (ii) The circuit shown in **Fig. 9(b)** requires an additional component to ensure circuit protection. With the aid of a diagram show how this could be achieved labelling the additional component. [2]
- (iii) Explain the operation of the circuit shown in **Fig. 9(b)**. [3]
 Quality of written communication [1]
- (iv) The relay in **Fig. 9(b)** is to be replaced with a double pole double throw (DPDT) relay in order to achieve a latching action. With the aid of an annotated circuit diagram explain how a DPDT relay can be used to latch the motor. [4]

10 Fig. 10(a) shows a logic circuit which uses switches as inputs and has 2 outputs. The circuit forms part of a supermarket call system where the till operator can “call” for assistance by pressing a switch. The system can be “cleared” by pressing a second switch.

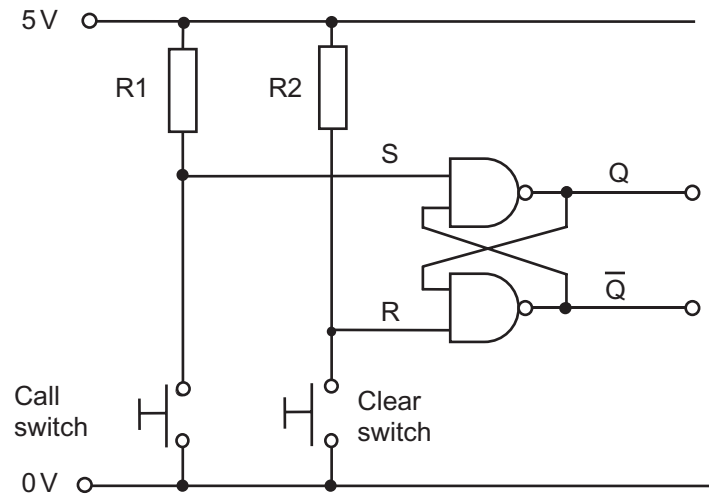

Fig. 10(a)

(a) (i) Name the arrangement of gates shown in Fig. 10(a). [1]

(ii) Draw the truth table for a 2 input NAND gate. [2]

(iii) State if the resistors R1 and R2 in the circuit shown in Fig. 10(a) are pull up or pull down resistors and briefly justify your answer. [2]

(b) The table shown in Fig. 10(b) shows a typical sequence of operation for the circuit shown in Fig. 10(a).

Step	Call switch Pressed?	Clear switch Pressed?	S logic state	R logic state	Q logic state	\bar{Q} logic state
1	no	no	1	1	0	1
2	yes	no				
3	no	no				
4	no	yes				

Fig. 10(b)

In your answer book state all of the missing logic states for steps 2, 3 and 4 in the table shown in Fig. 10(b). [3]

- (c) A flashing LED circuit will act as the “call” signal in the supermarket. The LED is to be controlled by a circuit based on a 555 timer. The 555 timer circuit is shown in **Fig. 10(c)**.

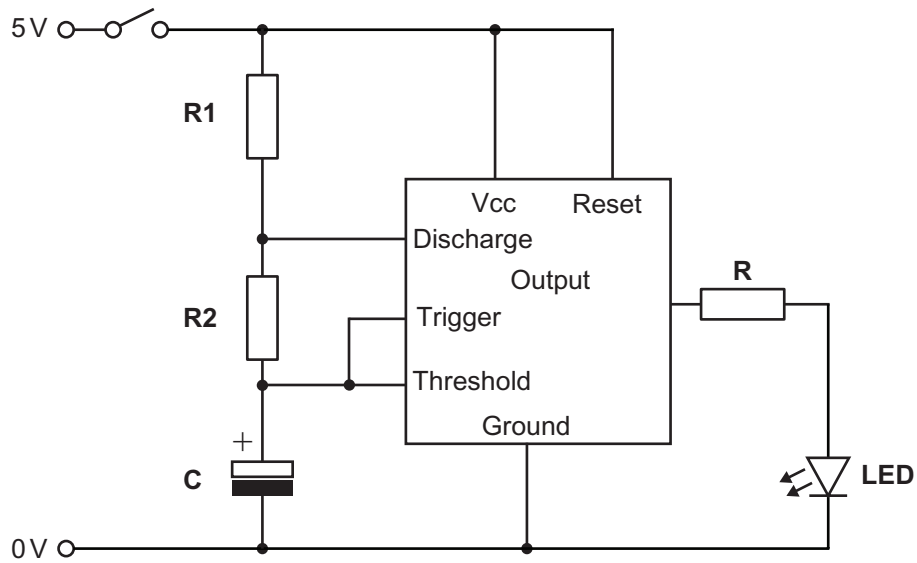

Fig. 10(c)

- (i) State **one** advantage of using a hard wired system such as a 555 timer over a PIC based system to control a flashing LED. [1]
- (ii) Sketch the output waveform for an astable timer with a **mark/space** ratio of 1:1. Label your sketch, indicating the **mark, space** and **period** on the waveform. [3]
- (d) An LED is to be connected to the 555 timer along with a protective resistor (R) as shown in **Fig. 10(c)**. The LED is designed to work at a forward voltage of 1.8 volts and a current of 15 mA.
- (i) Calculate the value of R required to allow the LED to function safely. (Assume the output voltage from the 555 timer is 5V). [2]
- (ii) Choose a practical value for R from the E12 preferred value series 10, 12, 15, 18, 22, 27, 33, 39, 47, 56, 68, 82, and justify your choice. [2]
- Quality of written communication [1]
- (iii) Given that the output frequency f of the astable timer shown in **Fig. 10(c)** is given by the equation $f = 1.44/(R1+2R2)C$, calculate the value for C (assume $R1 = 3.9\text{k}\Omega$ and $R2 = 34\text{k}\Omega$) required to make the LED flash on and off 2 times per second. [3]

Section C

Mechanical and Pneumatic Control Systems

Answer both questions in this section **or** both questions in Section B **or** both questions in Section D.

You are advised to spend approximately **1 hour** on this section.

11 Fig. 11 shows part of a mechanical system.

- (a) (i) Looking in the direction of arrow **Z**, state the direction of rotation at **E** if **A** rotates in an anticlockwise direction. [1]
- (ii) Calculate the velocity ratio between **A** and **Wormwheel F**. [3]
- (iii) Calculate the difference in output speeds between **D** and **E** if the motor rotates at 500 rev/min. [3]
- (iv) Calculate the output speed at **Shaft X** if the motor rotates at 500 rev/min. [3]
- (v) **Wormwheel F** is to be replaced with one of an alternative size. Calculate the size of wormwheel required to produce an output speed at **Shaft X** of 50 rev/min if the motor rotates at 500 rev/min. [3]
- (vi) Describe **two** main safety issues associated with the mechanical system shown in **Fig. 11**. Your answer should make reference to procedures which could minimise any hazards outlined. [2]
- Quality of written communication [1]
- (b) (i) **Shaft X** is to be used to operate an eccentric cam which will be connected to a roller follower. Using an annotated sketch draw this cam and follower arrangement. [3]
- (ii) Briefly describe the term stroke length when applied to cams and followers. [1]

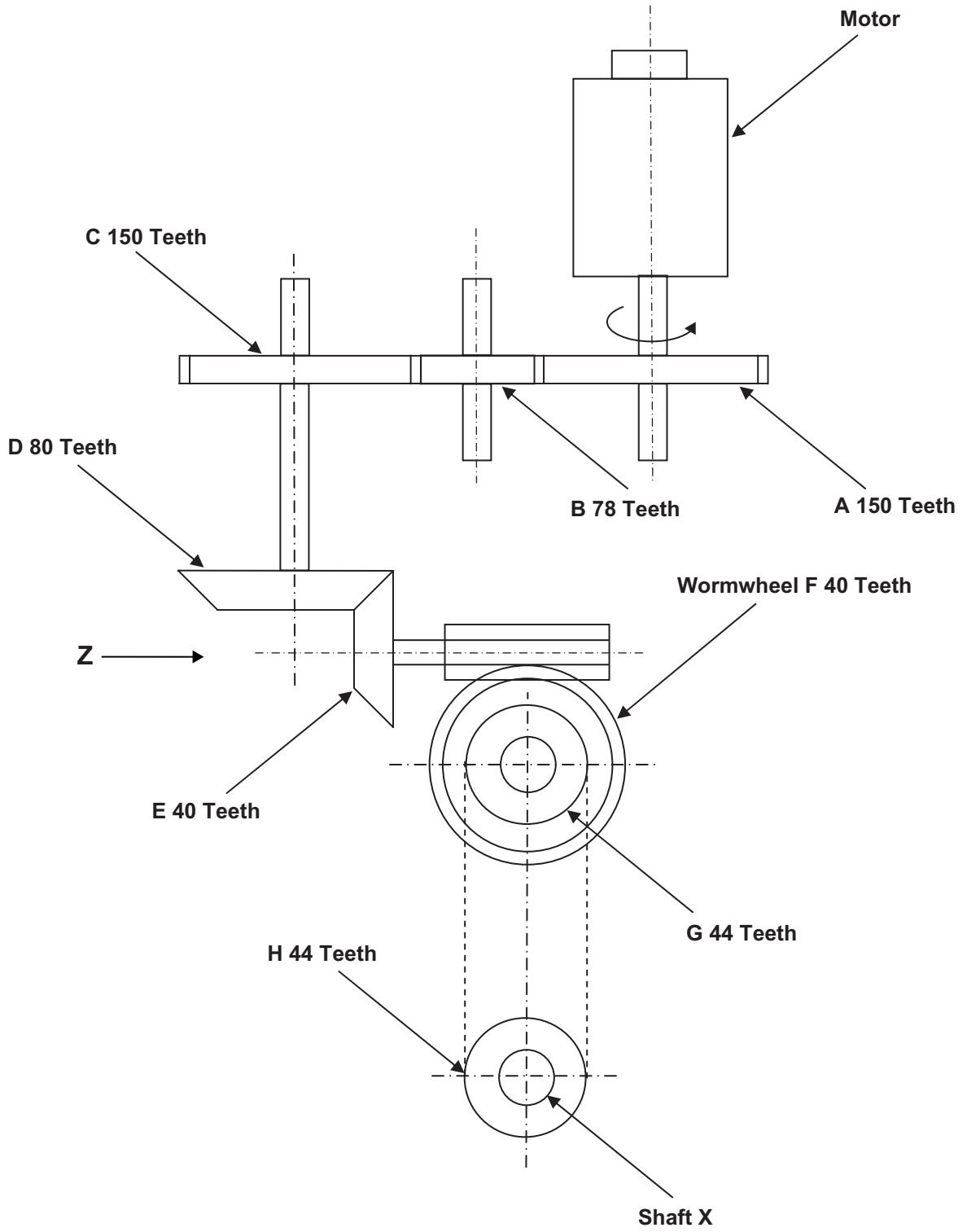

Fig. 11

- 12 (a)** Briefly describe the use of filter and lubricator units in a typical compressor installation. [2]
- (b) Fig. 12** shows an incomplete pneumatic system which is to be used to move boxes from **Conveyor belt X** to **Conveyor belt Y**.
- (i)** Name the activation method at **A**. [1]
- (ii)** Name the activation method at **B**. [1]
- (iii)** Name the activation method at **C**. [1]
- (iv)** On the pro forma provided (answer numbers **12(b)(iv)** and **(v)**) develop the circuit to enable a combined activation at **A and B and C and D** to signal the five port valve to outstroke the double acting cylinder. Please note that **D** is expected to use a solenoid activation method which is to be signalled when the microswitch is pressed by a box. [5]
- (v)** On the pro forma provided (answer numbers **12(b)(iv)** and **(v)**) modify the circuit to add a safety feature which will cut off the main air supply to the five port valve if required. Add any necessary components with a suitable activation method to enable the main air supply to be switched on or off. [3]
- (vi)** Describe how the double acting cylinder shown on **Fig. 12** instrokes automatically following an outstroke. Your explanation should include reference to the names of the components used and the flow of air. [3]
- Quality of written communication [1]
- (vii)** The double acting cylinder when supplied with an air pressure of 0.5 N/mm^2 , produces a force of 90 N during the outstroke and a force of 64.88 N during the instroke. Calculate the piston rod radius. Please assume $\pi = 3.14$. [3]

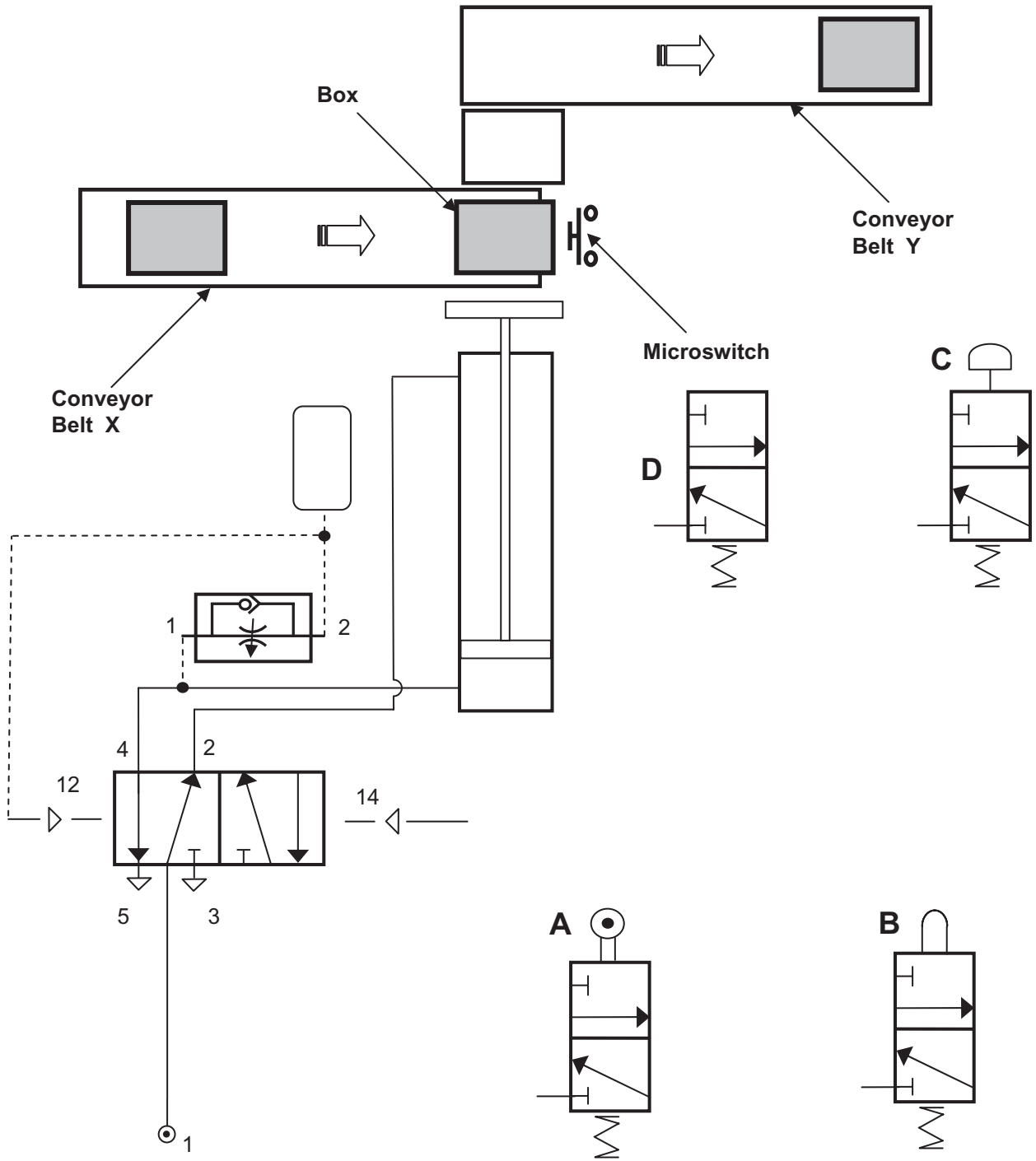

Fig. 12

Section D

Product Design

Answer **both** questions in this section **or** both questions in Section B **or** both questions in Section C.

You are advised to spend approximately **1 hour** on this section.

13 (a) With reference to **Fig. 13** on the insert sheet;

(i) Outline **two** specifically different target audiences that this product has been designed for. [2]

(ii) For the product shown in **Fig. 13** briefly outline **two** different ways in which the designer has taken into consideration the safety of the user. [2]

(iii) The high chair shown in **Fig. 13** is to be packaged using a bio-degradable plastic.

Briefly outline **one** main characteristic associated with bio-degradable plastic which makes it suitable for packaging. [1]

(iv) With reference to **Fig. 13** briefly outline **two** different aspects in support of the view that this is a low cost product. [2]

(v) For the product shown in **Fig. 13** outline **two** different ways in which the designer has incorporated ergonomics in order to make the product more suitable for the user. [2]

Quality of written communication [1]

(vi) For future developments the designer is considering manufacturing the moulded seat of the highchair in **Fig. 13** from thermoplastic elastomers.

Briefly outline **two** main characteristics of thermoplastic elastomers which would make them suitable for the seat of the highchair. [2]

(b) With the aid of detailed annotated sketches, using the blank A3 pro forma answer page (answer numbers **13(b)(i)** and **(ii)**), complete each of the following:

(i) a suitable design that will enable the user to extend the length of each of the legs. [4]

(ii) a suitable means of ensuring that when the legs are extended the high chair maintains stability. [4]

14 Fig. 14(a), (b), (c) and (d) on the insert page show photographs of a pump and spray bottle designed to be used by a gardener when applying insecticides and pesticides to a range of plants and shrubs.

(a) When designing this product designers engaged with the client by creating a design brief and specification and by using formative and summative evaluation techniques.

(i) Briefly explain the difference between a design brief and a design specification. [2]

(ii) Distinguish between formative and summative evaluation techniques. [2]

(b) Before the product was to be manufactured designers made a number of recommendations. One was to consider registering the design and a second was to produce a leaflet explaining to customers how to disassemble the product which would be subject to copyright.

(i) Outline **two** main characteristics associated with a registered design. [2]

(ii) Outline **two** main characteristics associated with a copyright. [2]

(c) In order to determine the suitability of the materials for the product chemical insecticides and pesticides were used during testing. When using such chemicals the company carrying out the tests needed to comply with the COSHH regulations.

Outline **three** main characteristics associated with the COSHH regulations. [3]

Quality of written communication [1]

(d) On the blank A3 pro forma answer page (answer numbers **14(d)(i)** and **(ii)**) use detailed annotated sketches to produce **one** possible solution for each of the following:

(i) An appropriate design of a pictogram for the spray bottle that will inform the user to hold the handle to rotate the bottle anticlockwise in order to remove it for refilling. **(Fig. 14(a))**. [4]

(ii) Sketches of a suitable design of a safety catch that can be quickly engaged/disengaged to prevent the trigger being pressed accidentally and releasing harmful chemicals. **(Fig. 14(c))**. [4]

THIS IS THE END OF THE QUESTION PAPER

Permission to reproduce all copyright material has been applied for.
In some cases, efforts to contact copyright holders may have been unsuccessful and CCEA
will be happy to rectify any omissions of acknowledgement in future if notified.



Rewarding Learning

**ADVANCED SUBSIDIARY (AS)
General Certificate of Education
2013**

Technology and Design

Assessment Unit AS 1

assessing

**Product Design and
Systems and Control**

[AV111]



TUESDAY 4 JUNE, MORNING

INSERT

(for use with Questions 7(ii), 13 and 14)

(for use with Question 7(ii))

Do not write your answers on this insert



Fig. 7

Photos: R Farmer, Principal Examiner, CCEA

GCE Advanced Subsidiary (AS) Technology and Design
Assessment Unit AS 1 Summer 2013

(for use with Question 13)

Do not write your answers on this insert



Fig. 13

Photos: R Farmer, Principal Examiner, CCEA

GCE Advanced Subsidiary (AS) Technology and Design
Assessment Unit AS 1 Summer 2013

(for use with Question 14)

Do not write your answers on this insert

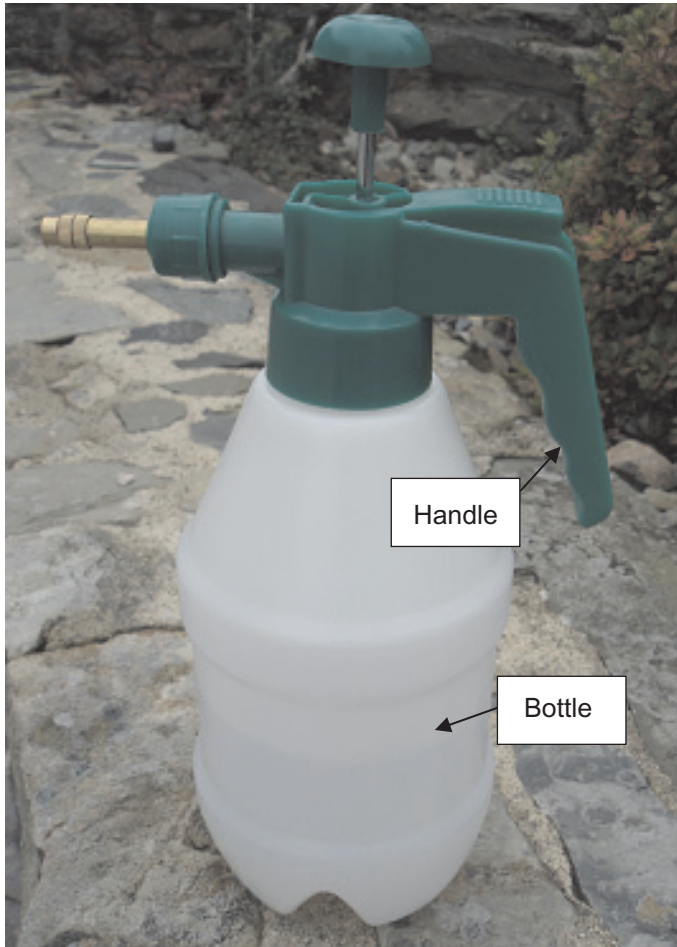

Fig. 14(a)

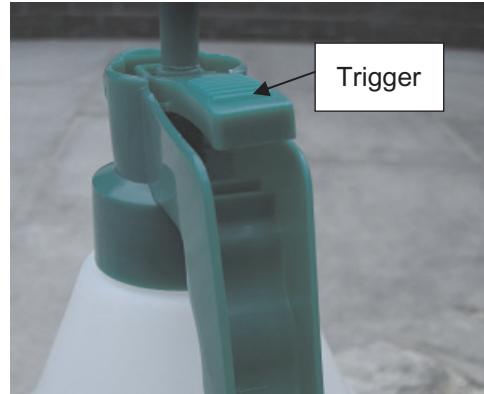

Fig. 14(c)



Fig. 14(d)



Fig. 14(b)

Photos: R Farmer, Principal Examiner, CCEA

Fig. 14

Question No. 13(b)(i) and (ii)

ADVANCED SUBSIDIARY (AS) TECHNOLOGY AND DESIGN
Assessment Unit AS 1 Unit 1
2013

Centre Number

71	
----	--

Candidate Number

--

**Pro forma answer page
(answer numbers 13(b)(i) and (ii))**

Question No. 14(d)(i) and (ii)

ADVANCED SUBSIDIARY (AS) TECHNOLOGY AND DESIGN
Assessment Unit AS 1 Unit 1
2013

Centre Number

71

Candidate Number

**Pro forma answer page
(answer numbers 14(d)(i) and (ii))**