



Rewarding Learning

ADVANCED SUBSIDIARY (AS)
General Certificate of Education
2012

Technology and Design

Assessment Unit AS 1

assessing

Product Design and
Systems and Control

[AV111]



WEDNESDAY 13 JUNE, AFTERNOON

TIME

2 hours.

INSTRUCTIONS TO CANDIDATES

Write your Centre Number and Candidate Number on the Answer Booklet provided and on the A3 pro forma answer page provided.

Answer **all eight** questions in Section A, and both questions in Section B **or** Section C **or** Section D.

A3 pro forma answer pages are provided for Questions **11(a)(iii)** and **12b(i), (ii)** and **(iii)** in Section C, and for Questions **13(b)(i)** and **(ii)** and **14(d)** in Section D.

You are provided with an insert for use with Question 13 and an insert for use with Question 14. At the conclusion of the examination, attach the A3 pro forma answer pages securely to the Answer Booklet with the treasury tag supplied.

INFORMATION FOR CANDIDATES

The total mark for this paper is 80, including a maximum of 4 marks for quality of written communication.

Marks for quality of written communication will be awarded for questions **8, 9(b)(ii), 10(a)(v), 11(b)(v), 12(c), 13(a)(iv)** and **14(c)**.

Figures in brackets printed down the right-hand side of pages indicate the marks awarded to each question or part question.

Questions do not all carry equal weighting.



Section A

Product Design and Practice

Answer **all** questions in this section.

You are advised to spend approximately **1 hour** on this section.

- 1** When selecting a material for an outdoor product, designers need to consider the cost of materials and the available common forms and sizes of material.
- (i)** Give **two** main reasons why the designer has to consider the cost of materials when selecting a material for an outdoor product. [2]
 - (ii)** Give **two** main reasons why the designer would use common forms and sizes of material for outdoor products. [2]
- 2** The specific properties and characteristics of oak and ash make them suitable for a wide range of products.
- (i)** State **one** specific application for the use of oak and briefly outline **one** main property which makes this wood suitable for your chosen application. [2]
 - (ii)** State **one** specific application for the use of ash and briefly outline **one** main property which makes this wood suitable for your chosen application. [2]
 - (iii)** Stains or oils may be used on oak or ash as a finish. Briefly explain the main purpose of stains and the main purpose of oils. [2]
- 3** Injection moulding is a process which may be used to manufacture cases for hairdryers, vacuum cleaners and computer monitors.
- (i)** Give **two** main reasons why the injection moulding process may be used to manufacture these cases. [2]
 - (ii)** With the aid of an annotated sketch describe the injection moulding process. [4]

- 4 Knock down fittings and riveting are often used to join materials.
- (i) With the aid of annotated sketches explain how knock down fittings are used to join materials. [3]
 - (ii) With the aid of annotated sketches explain how rivets are used to join materials. [3]
- 5 Virtual imaging and rapid prototyping may be used in the design of products.
- (i) Outline **two** main characteristics associated with virtual imaging. [2]
 - (ii) Outline **two** main characteristics associated with rapid prototyping. [2]
- 6 Manufacturers of soft drinks bottles use statistical testing methods, Quality Control (QC) and Quality Assurance (QA) procedures in an effort to drive improvement.
- (i) Explain how the manufacturer of the soft drinks bottles would use statistical testing methods. [2]
 - (ii) Explain the difference between QA and QC procedures. [2]

7 Anthropometrics and ergonomics help determine the shape and profile of many products.



© iStockphoto / Thinkstock

Fig. 7

(i) With reference to **Fig. 7** explain how anthropometric data may have been used in the design of the product. [2]

(ii) Select **two** aspects of the toothbrush in **Fig. 7** and explain how the designer may have incorporated ergonomics. [2]

8 Scientific advances and cultural changes can have an influence on the design of products such as a television.

(i) With reference to any suitable product, outline **one** main scientific advancement and explain what influence this has had on its design. [2]

(ii) With reference to any suitable product, outline **one** main culture change and explain what influence this has had on its design. [2]

Quality of written communication [2]

BLANK PAGE
(Questions continue overleaf)

Section B

Electronic and Microelectronic Control Systems

Answer both questions in this section **or** both questions in Section C **or** both questions in Section D.

You are advised to spend approximately **1 hour** on this section.

- 9 (a) A circuit consisting of a reed switch and resistor is shown in **Fig. 9(a)**.

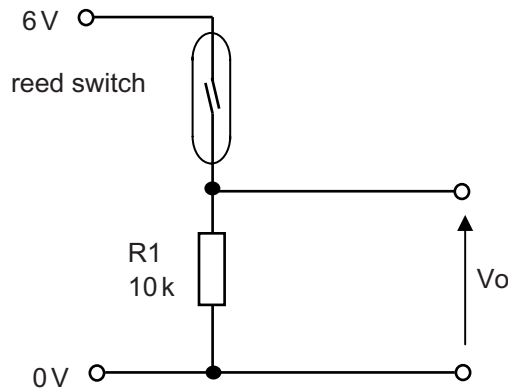

Fig. 9(a)

- (i) Describe the operation of a reed switch. [2]
- (ii) The resistor **R1** in the circuit shown in **Fig. 9(a)** is a pull down resistor. With reference to the voltage **V_o** , briefly explain the purpose of the pull down resistor. [2]

(b) Fig. 9(b) shows a circuit that utilises reed switches to detect if the emergency doors in a building have been opened.

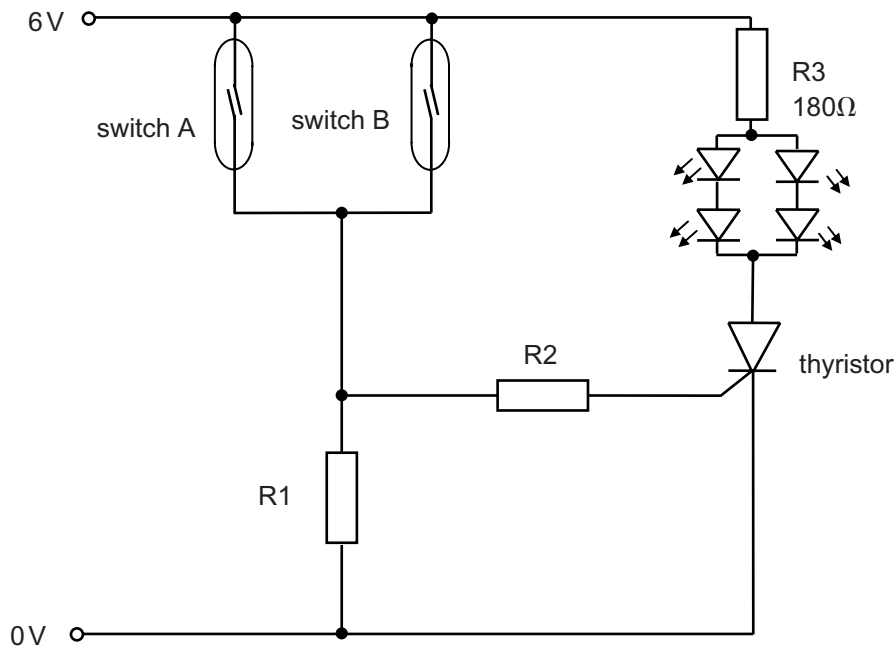

Fig. 9(b)

(i) State the type of logic control achieved by the arrangement of reed switches in Fig. 9(b). [1]

(ii) Describe the operation of the circuit shown in Fig. 9(b). [3]

Quality of written communication [1]

(iii) Explain with the aid of a labelled diagram how the circuit shown in Fig. 9(b) could be modified to incorporate a reset feature. [3]

(iv) Calculate the power dissipated in mW by the resistor R3 in Fig. 9(b) if the LEDs shown are each designed to operate at a forward voltage of 1.8V and a current of 10mA. Then select a resistor with the most appropriate rating from the following: 0.125W, 0.25W, 0.5W and 1W. [3]

(c) An alternative circuit for the emergency door detector shown in Fig. 9(b) could be constructed using an SR flip flop with input switches and pull up resistors.

Design an SR flip flop based circuit (using NAND gates) to perform the same function as the circuit in Fig. 9(b). Show how the reed switches could be connected and label any additional switches. [5]

10 (a) Fig. 10(a) shows a prototype op amp based circuit for a system to keep newly hatched chicks warm. The system controls a 12 volt bulb that will produce sufficient heat to maintain room temperature.

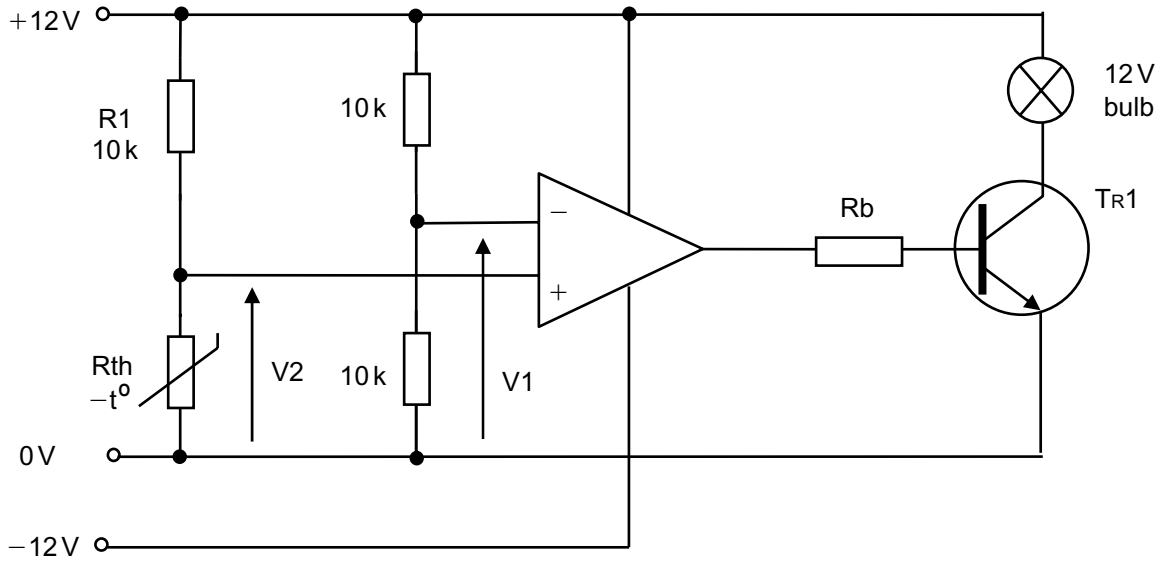

Fig. 10(a)

- (i) State whether the comparator based circuit shown in Fig. 10(a) is an open loop or closed loop control system and briefly justify your answer. [2]
 - (ii) The component R_{th} has a negative temperature coefficient. With the aid of a labelled graph explain what is meant by the term negative temperature coefficient. [3]
 - (iii) Calculate the voltage V_1 in the circuit shown in Fig. 10(a) and calculate the voltage V_2 when the resistance of the thermistor R_{th} is $4.2k\Omega$ at 15°C . [3]
 - (iv) If the transistor TR_1 in Fig. 10(a) has a current gain (h_{FE}) of 60 and a V_{be} of 0.6V , calculate the required value of R_b that will allow the bulb to operate with a current of 120mA . Assume that the output voltage of the op amp matches the supply voltage. [3]
 - (v) With reference to V_1 and V_2 describe the operation of the circuit shown in Fig. 10(a) under both hot and cold conditions. [3]
- Quality of written communication [1]

(b) A modification has been suggested for the circuit shown in Fig. 10(a) where the transistor and 12 volt bulb are to be replaced with a 24 volt heater and suitable driving circuitry.

With the aid of an annotated circuit diagram, show how this modification could be achieved.

[5]

Section C

Mechanical and Pneumatic Control Systems

Answer both questions in this section **or** both questions in Section B **or** both questions in Section D.

You are advised to spend approximately **1 hour** on this section.

- 11 (a) Fig. 11(a)** shows an incomplete sawing system powered by a motor **M**. The motor **M** turns shaft **K** and the **cutting blade** is intended to move forwards and backwards in a straight path.
- (i) State the types of motion at **Shaft K** and the **cutting blade**. [2]
- (ii) During testing when the sawing system is fully functional it is recorded as having a mechanical advantage of 4 and a velocity ratio of 5. Calculate the efficiency of the sawing system. [2]
- (iii) On the pro forma provided (answer number **11(a)(iii)**) name and draw a suitable mechanism to allow the **cutting blade** to move forwards and backwards as **Shaft K** rotates. [3]

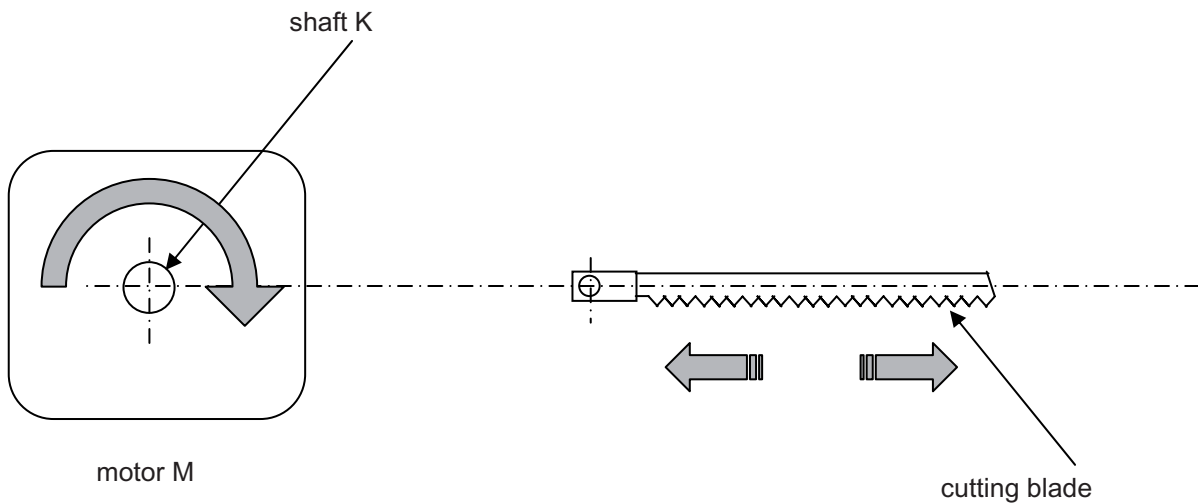

Fig. 11(a)

(b) **Fig. 11(b)** opposite shows another incomplete mechanical system powered by motor **N**. The rack moves when the motor **N** rotates.

(i) State the direction of rotation at **F** if **X** rotates in a clockwise rotation. [1]

(ii) Calculate the output speed of pulley **X** if the motor **N** rotates at 440 rev/min. [3]

(iii) Calculate the velocity ratio between pulley **A** and gear **E**. [3]

(iv) Calculate the linear movement of the rack if gear **E** makes **four** rotations. Assume a 180 degree rotation of the pinion gear moves the rack 148mm. [3]

(v) Describe **two** safety procedures which should be used when working with mechanical systems. [2]

Quality of written communication [1]

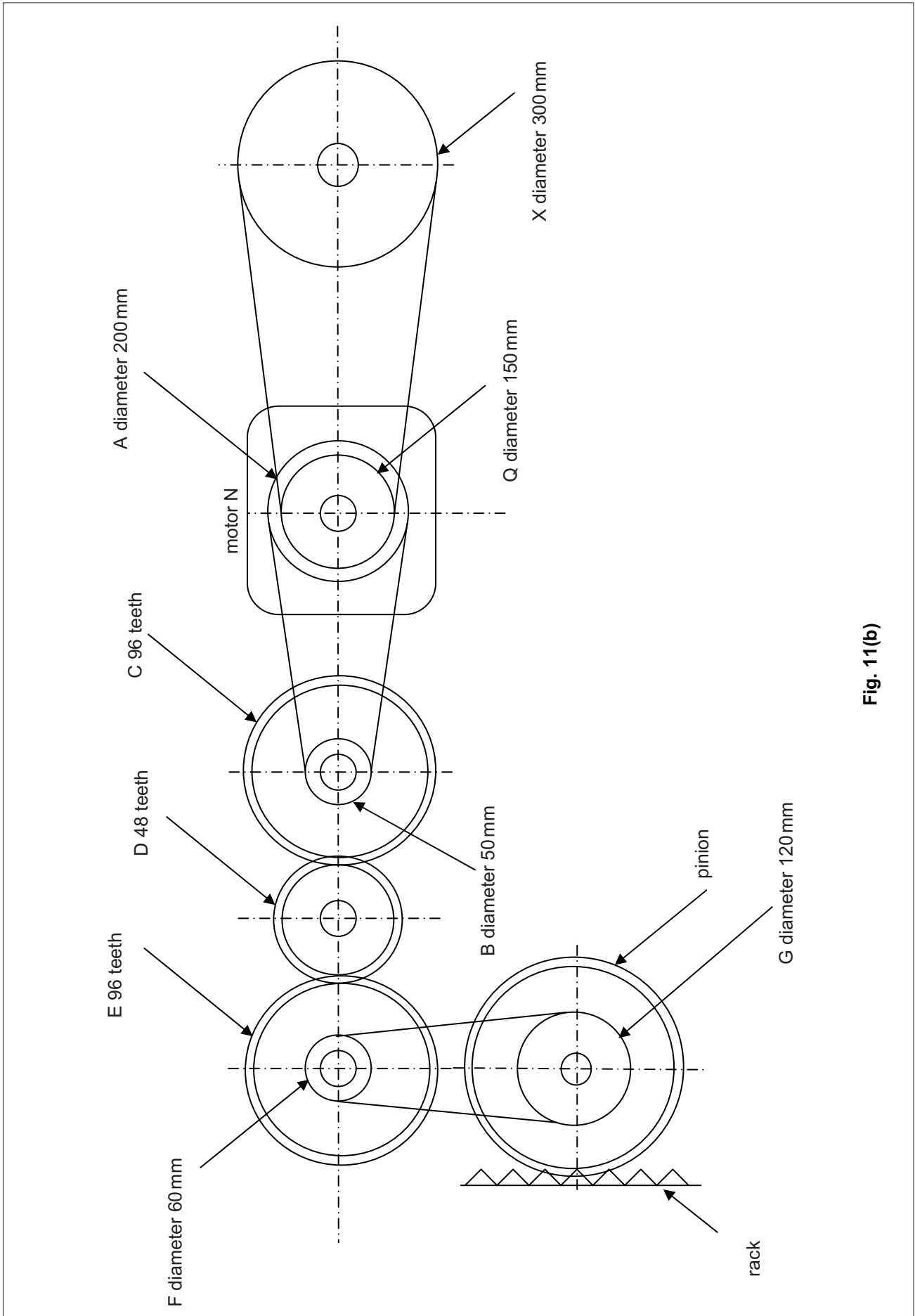

Fig. 11(b)

12 Fig. 12 shows part of an incomplete pneumatic circuit.

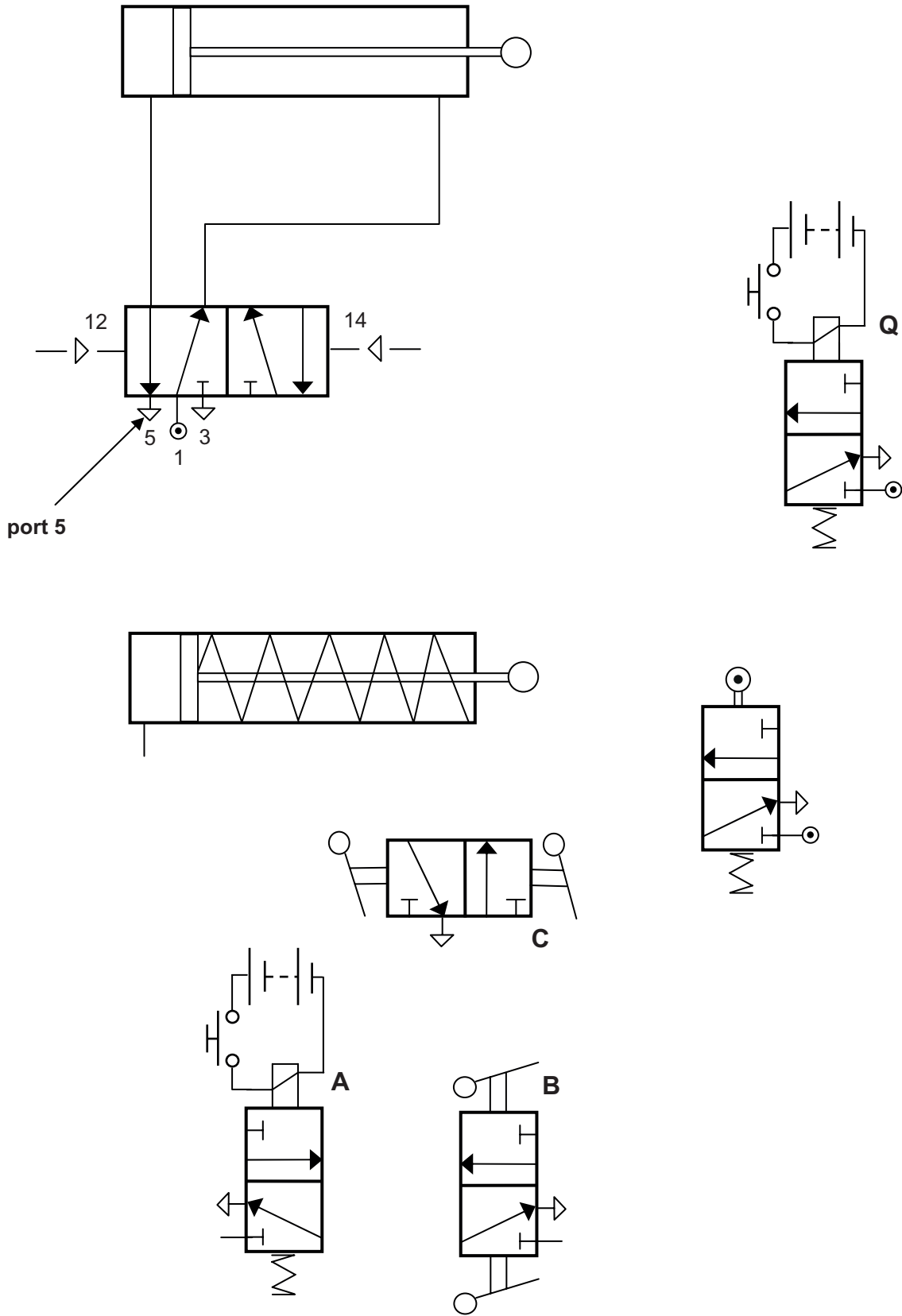

Fig. 12

- (a) (i) Name the activation method at **A**. [1]
- (ii) State the purpose of the symbol shown on **port 5** on the double acting cylinder. [1]
- (iii) Name the activation method at **B**. [1]
- (b) (i) On the pro forma provided (answer numbers **12(b)(i)**, **(ii)** and **(iii)**), complete the circuit to enable the double acting cylinder to instroke following an outstroke from the single acting cylinder. [3]
- (ii) On the pro forma provided (answer numbers **12(b)(i)**, **(ii)** and **(iii)**), complete the circuit to enable the single acting cylinder to outstroke once **A**, **B** and **C** have been activated. [4]
- (iii) On the pro forma provided (answer numbers **12(b)(i)**, **(ii)** and **(iii)**), complete the circuit to enable the double acting cylinder to outstroke following an instroke from the single acting cylinder or **Q** being activated. [4]
- (c) Describe a main safety issue and procedure used for Pneumatic control systems. [2]
- Quality of written communication [1]
- (d) A single acting cylinder is required to produce a force during the outstroke of 212 N using an air pressure of 0.4 N/mm^2 . Select one of the following single acting cylinders which could best meet the requirement:
- Cylinder L – piston radius 6 mm
 Cylinder M – piston radius 9 mm
 Cylinder O – piston radius 13 mm
 Cylinder P – piston radius 15 mm
 Cylinder Q – piston radius 17 mm
 Please assume $\pi = 3.14$ [3]

Section D

Product Design

Answer both questions in this section **or** both questions in Section B **or** both questions in Section C.

You are advised to spend approximately **1 hour** on this section.

- 13 (a)** With reference to **Fig. 13(a), (b), (c)** and **(d)** on the insert sheet;
- (i)** Briefly outline **three** specific functional criteria that a designer would need to include in the design specification for this product. [3]
 - (ii)** Briefly outline **three** main criteria that would influence the selection of the material to be used for the tubular shaft of the dustpan (**Fig. 13(b)**). [3]
 - (iii)** Briefly outline **three** main reasons why folded boxboard is the material used for the packaging of the dustpan and broom (**Fig. 13(a)**). [3]
 - (iv)** Under the Intellectual Property Rights (IPR) for the product the designer registered the design. Outline **two** characteristics associated with registered designs. [2]
- Quality of written communication [1]
- (b)** With the aid of detailed annotated sketches, using the blank A3 pro forma answer page (answer numbers **13(b)(i)** and **(ii)**), suggest for each of the following:
- (i)** An appropriate handle for the broom which will be more ergonomically suited to the user whilst minimising the use of material (**Fig. 13(d)**). [4]
 - (ii)** An appropriate end for the tubular shaft which would enable the user to quickly remove the brush head and replace it with other attachments (**Fig. 13(c)**). [4]

14 Fig. 14 on the insert page, shows a photograph of an electric shaver designed for a mature male target audience.

(a) The electric shaver could be produced in model form using a laser cutter and a range of workshop processes such as drilling, cutting, filing and polishing.

(i) With the use of an annotated sketch describe the process of laser cutting. [3]

(ii) The table below shows an incomplete five stage risk assessment for the vertical pillar drill, used when drilling plastic, wood or metal. Briefly outline the appropriate content for stages 2, 3, 4 and 5 in the answer booklet.

Do not write your answers on the table below.

Stage	Vertical pillar drill
1. Hazard identified	When drilling the potential hazard of rotating or spinning material
2. Who is at risk and how?	
3. Precautions	
4. Record findings	
5. Review your assessment	

[4]

(b) For promotional purposes it is planned to manufacture a number of large scale models of the electric razor using carbon fibre reinforced plastic (CFRP).

Briefly outline **two** main characteristics associated with carbon fibre reinforced plastic (CFRP) which make it suitable for production of such models. [2]

(c) To assist in the planning for manufacture of the electric shaver shown in **Fig. 14** a Gantt chart is to be used. Explain **two** main characteristics associated with a Gantt chart. [2]

Quality of written communication [1]

- (d) As a designer you have been asked to consider the problem of re-designing the casing of the electric shaver shown in **Fig. 14** for a target audience of males of all ages who may be frequent travellers. On the blank A3 pro forma answer page (answer number **14(d)**) provide a response for each of the following:
- An annotated sketch showing how the aesthetics of the electric shaver could be changed to make it more appealing for a target audience of all ages. [3]
 - Outline **three** main requirements of an electric shaver that could be used by a frequent traveller. [3]
 - Suggest a suitable specific material and manufacturing process for the casing. [2]

THIS IS THE END OF THE QUESTION PAPER

Permission to reproduce all copyright material has been applied for.
In some cases, efforts to contact copyright holders may have been unsuccessful and CCEA
will be happy to rectify any omissions of acknowledgement in future if notified.

71	
----	--

--

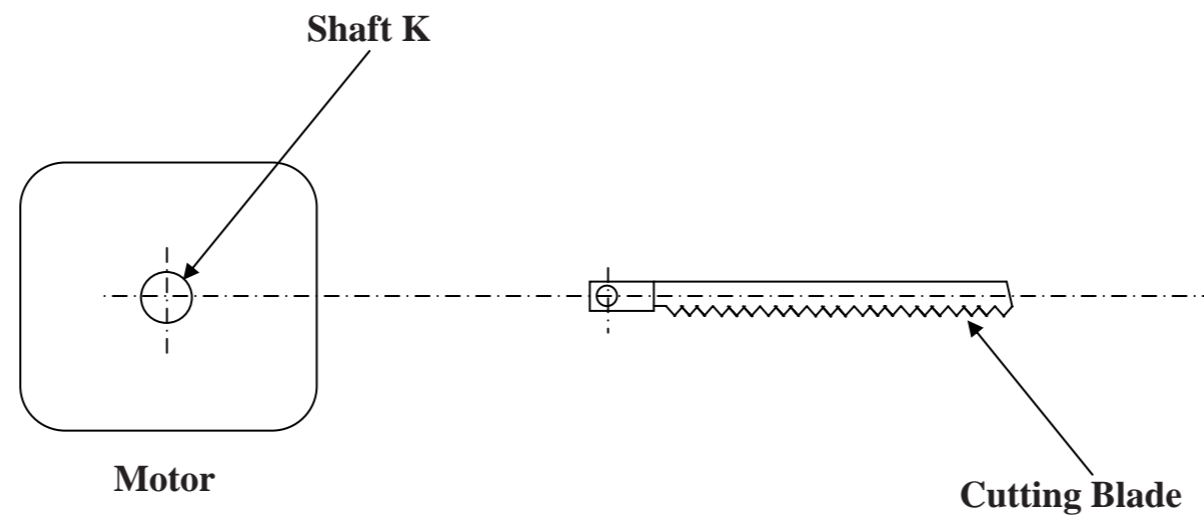

Pro forma answer page
(answer number 11(a)(iii))

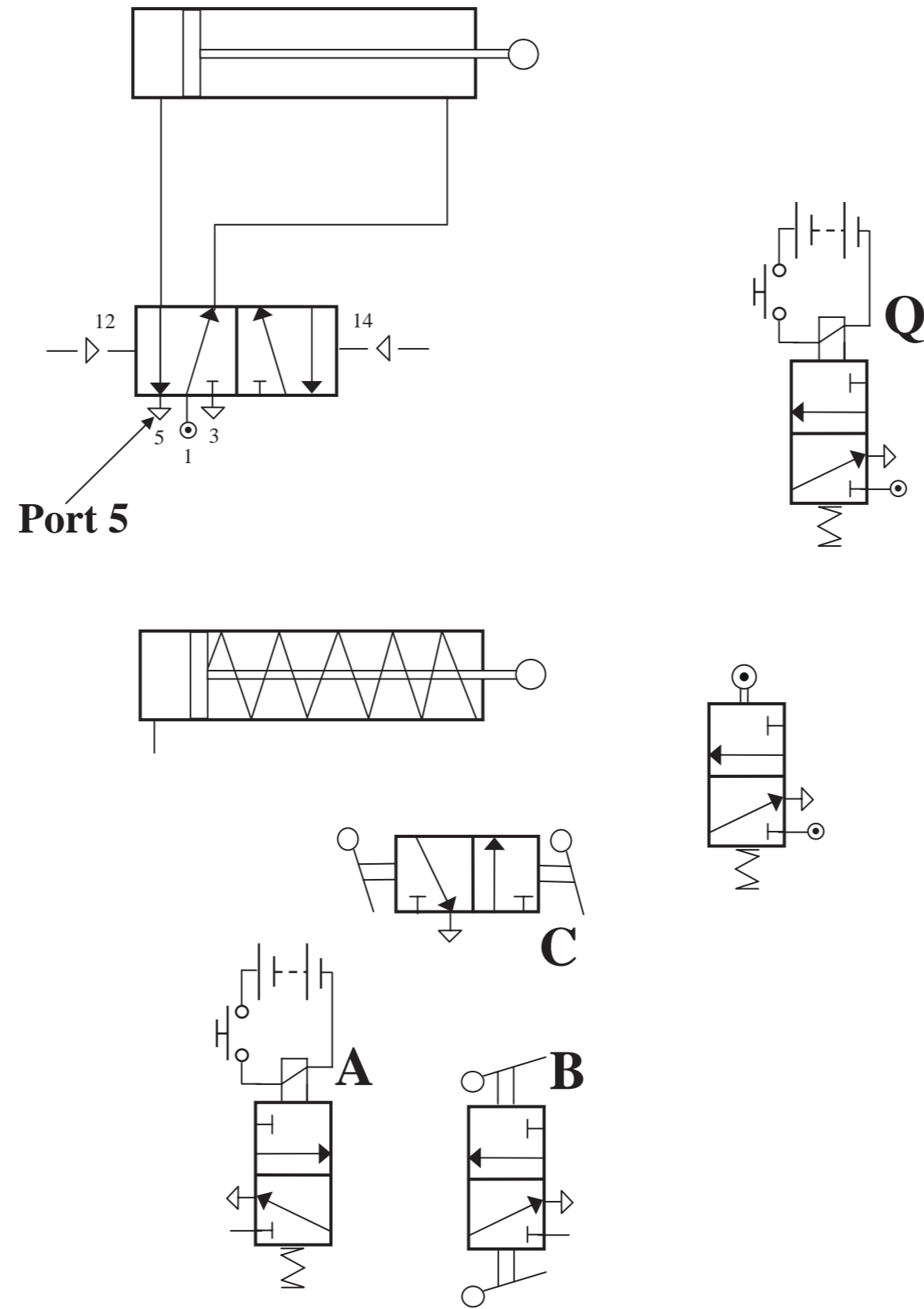

Pro forma answer page
 (answer numbers 12(b)(i), (ii) and (iii))

Question No. 13(b)(i) and (ii)

ADVANCED SUBSIDIARY (AS) TECHNOLOGY AND DESIGN
Assessment Unit AS 1 Unit 1
2012

Centre Number

71

Candidate Number

**Pro forma answer page
(answer numbers 13(b)(i) and (ii))**

Question No. 14(d)

ADVANCED SUBSIDIARY (AS) TECHNOLOGY AND DESIGN
Assessment Unit AS 1 Unit 1
2012

Centre Number

71

Candidate Number

**Pro forma answer page
(answer number 14(d))**

**GCE Advanced Subsidiary (AS) Technology and Design
Assessment Unit AS 1 Summer 2012**

(for use with Question 14)

Do not write your answers on this insert



Fig. 14



GCE Advanced Subsidiary (AS) Technology and Design
Assessment Unit AS 1 Summer 2012

(for use with Question 13)

Do not write your answers on this insert

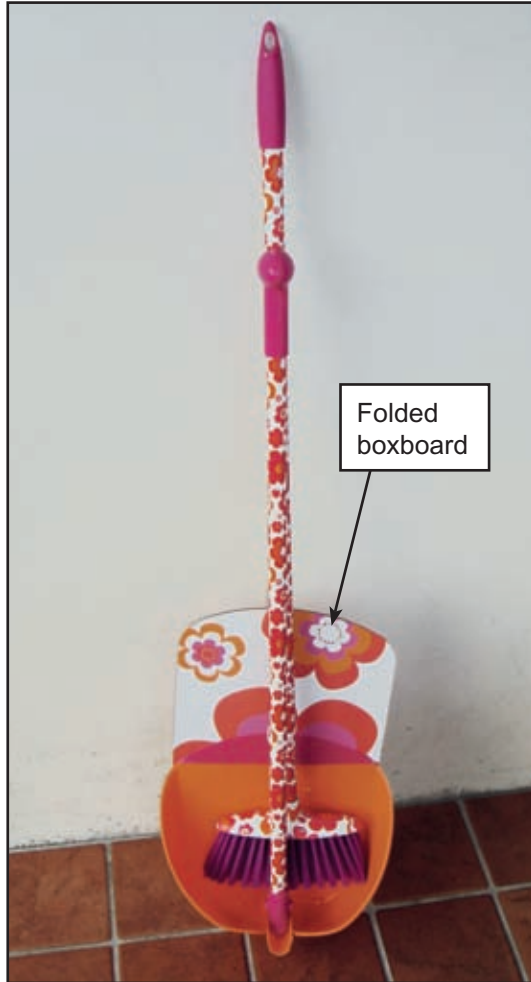

Fig. 13(a)



Fig. 13(b)

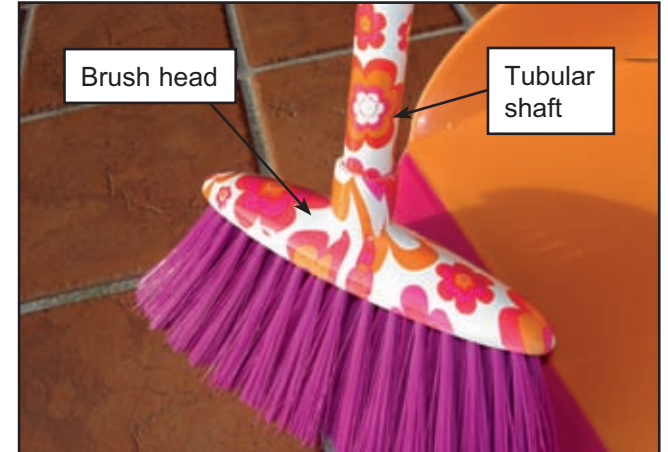

Fig. 13(c)

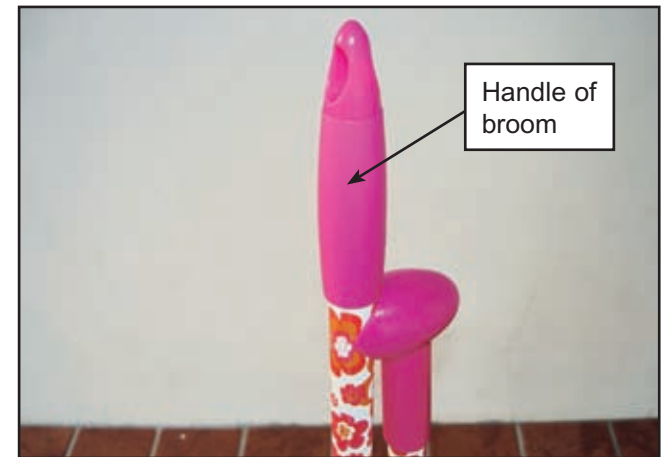

Fig. 13(d)



