



ADVANCED
General Certificate of Education
2011

Technology and Design

Assessment Unit A2 1

assessing

Systems and Control

[AV211]



WEDNESDAY 18 MAY, AFTERNOON

TIME

2 hours.

INSTRUCTIONS TO CANDIDATES

Write your Centre Number and Candidate Number on the Answer Booklet provided and on the A3 pro forma answer pages provided.

Answer **either** the **two** questions in Section A **or** the **two** questions in Section B.

Answers to questions **1(d)(iii)**, **2(d)**, **3(d)(i) and (ii)**, **4(c)(iii)** and **4(d)** should be made on the A3 pro forma answer pages provided.

At the conclusion of the examination, attach the A3 pro forma answer pages securely to the Answer Booklet with the treasury tag supplied.

INFORMATION FOR CANDIDATES

The total mark for this paper is 80, including a maximum of 4 marks for quality of written communication.

Marks for quality of written communication will be awarded for questions **1(e)** and **3(c)**.

Figures in brackets printed down the right-hand side of pages indicate the marks awarded to each question or part question.



Answer **either** the **two** questions in Section A **or** the **two** questions in Section B.

Section A

Electronic/Microelectronic Systems

1 A prototype design for a display system for an exhibition gallery is shown in **Fig. 1(a)**.

A number of columns, each with 3 faces, are rotated simultaneously by a stepper motor and belt drive. Each time the columns are rotated through 120° one of the 3 different faces will appear. One complete rotation of the stepper motor pulley will cause one complete rotation of the columns.

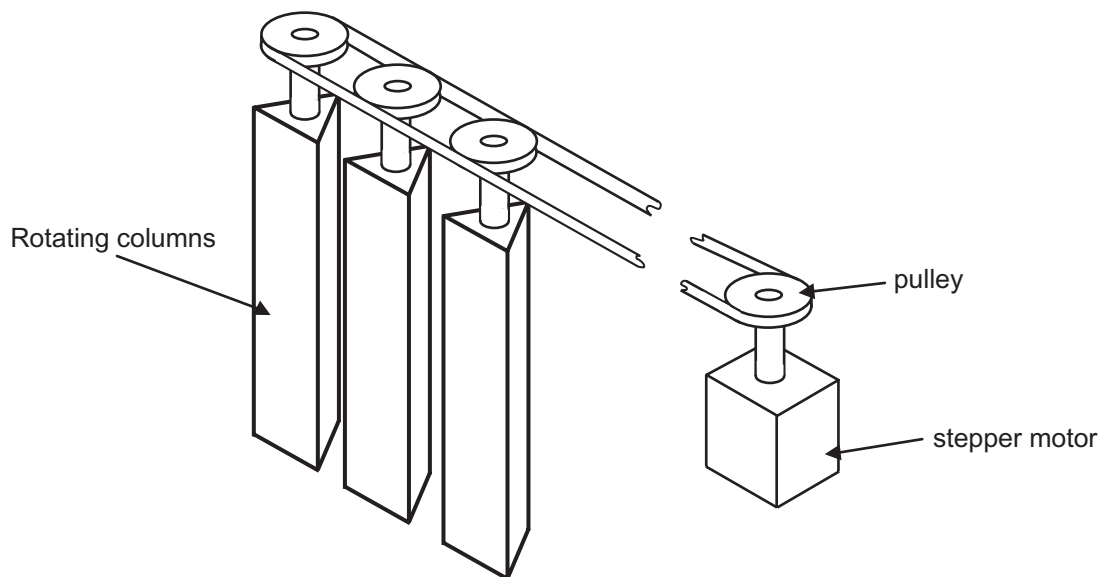

Fig. 1(a)

- (a) (i) The stepper motor shown in **Fig. 1(a)** has a step angle of 7.5° . Determine the number of steps required to rotate the motor by 120° . [1]
- (ii) Suggest **two** main reasons, other than cost why a stepper motor would be chosen over a DC motor for the system shown in **Fig. 1(a)**. [2]

(b) Part of the driver circuit for the stepper motor in Fig. 1(a) is shown in Fig. 1(b).

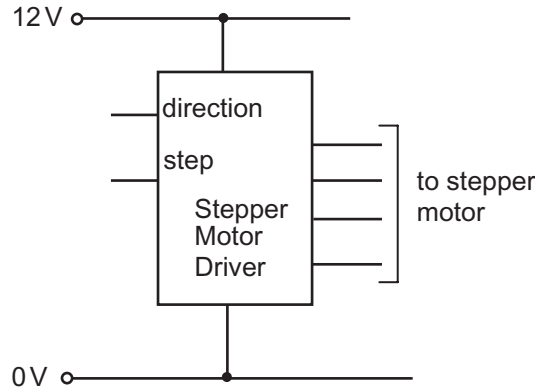

Fig. 1(b)

- (i) Explain the function of the **step** and **direction** pins on the stepper motor driver shown in Fig. 1(b). [2]
- (ii) Calculate the repetition rate of the step input if the stepper motor in Fig. 1(a) is required to rotate through 120° in 2 seconds. [2]

(c) Part of a circuit for a sensor to detect passing objects is shown in Fig. 1(c).

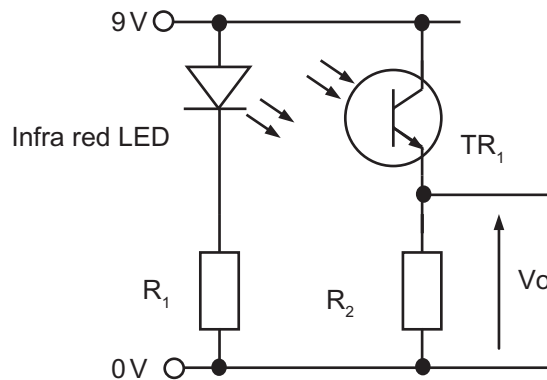

Fig. 1(c)

- (i) Name the component TR_1 shown in Fig. 1(c). [1]
- (ii) Give **one** reason why infra red light is used in conjunction with TR_1 shown in Fig. 1(c). [2]
- (iii) Explain with the aid of a labelled graph how the voltage V_o in Fig. 1(c) typically changes with time when a solid object passes between the LED and TR_1 . [2]

- (d) A systems diagram for a proposed PIC based system to operate the display shown in Fig. 1(a) is shown in Fig. 1(d). The circuit from Fig. 1(c) is to be utilised as a sensor to detect people entering the exhibition gallery in single file, via a corridor.

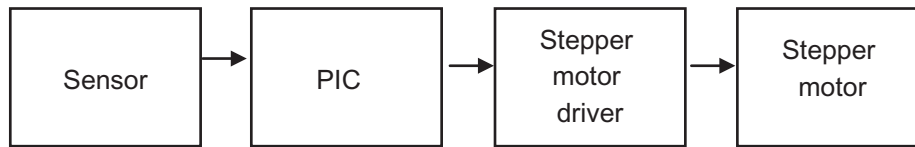

Fig. 1(d)

- (i) State if the system shown in Fig. 1(d) is open loop or closed loop and justify your answer. [4]
- (ii) It has been suggested that the sensor shown in Fig. 1(d) could be used as the input for a system to count and display the number of people entering the gallery which must not exceed 550. Draw an annotated block diagram based on a number of BCD counters, display drivers and seven segment displays to achieve this. Your answer should include an alarm that will sound when the maximum number of 550 is reached. [5]
- (iii) On the blank pro forma provided (answer number 1(d)(iii)) draw a complete annotated PIC based circuit diagram (and associated flowchart program) to produce a viable design based on the systems diagram shown in Fig. 1(d) that will fulfil the following points:
- Each time a person is detected entering the gallery, the display columns are to be rotated by 120° in 2 seconds before waiting for 5 seconds. This sequence should be repeated for one complete rotation of the columns. [4]
 - As a power saving measure the power supply to the stepper motor is to be disconnected if no people are detected entering the gallery. [6]
- (e) PICs are available with either digital inputs only or with mixed digital and analogue inputs. Explain the meaning of the terms digital and analogue when referring to PIC inputs. Choose a specific practical example of an electronic system that would benefit from using a PIC with mixed inputs. Justify your choice making reference to the specific features required of both types of input. [5]

Quality of written communication [4]

2 The diagram shown in **Fig. 2(a)** represents a system to prioritise the movement of forklift trucks in a busy warehouse. The simple traffic light units each contain two lights, a green light for go and a red light for stop. The sensors A, B and C which are embedded in the floor each produce a logic 1 when a forklift truck is detected above them, the traffic lights for the X and Y directions respond to the following conditions.

Green light on X when:

- No forklifts present
- Forklifts present at A, B and C
- Forklifts present at C and also at A or B
- Forklift present only at C

Green light on Y when:

- Forklifts present at A or B but no forklifts at C
- Forklifts present at both A and B but no forklifts at C

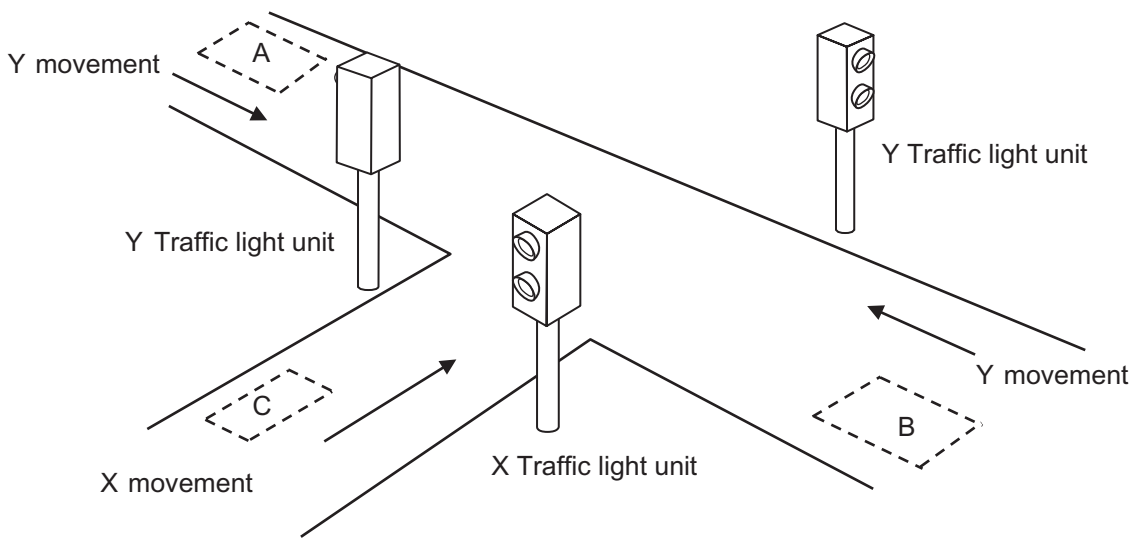

Fig. 2(a)

- (a) (i) With the aid of a diagram, describe a suitable sensor that could be used to detect the presence of the forklifts at A, B and C. [2]
- (ii) Draw a truth table to show all the logic combinations for A, B and C and the corresponding logic for the X green light and Y green light. [3]
- (iii) Minimise the logic expression for X and Y using Karnaugh maps. [4]
- (iv) Draw a logic circuit that would control the green and red lights on **both** X and Y traffic light units. [4]

- (b) A prototype system has been designed to monitor the distribution of the loads being carried on the steel forks of the forklift trucks. Each fork has 2 strain gauges aligned and attached to it as shown in **Fig. 2(b)**. When the load is lifted it is proposed that the truck operator will be able to check the distribution of weight between the right and left forks by looking at 2 bar graph displays which will be mounted in the cab unit.

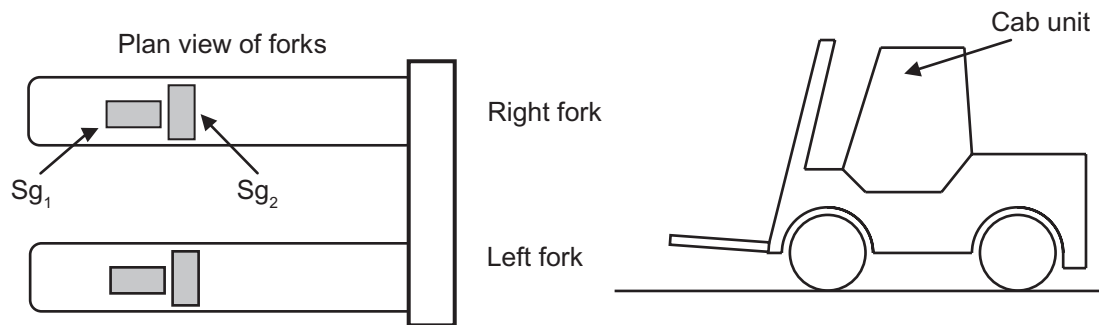

Fig. 2(b)

- (i) Describe the physical property associated with strain gauges which enable them to be used to measure strain. [2]
- (ii) With the aid of a diagram, describe the structure of a typical strain gauge. [2]
- (iii) State why changes in temperature can cause an error when using a strain gauge and explain how the arrangement of the gauges on each fork in **Fig. 2(b)** minimises such errors. [3]

- (c) The strain gauges on the right fork shown in **Fig. 2(b)** are connected as part of a circuit as shown in **Fig. 2(c)**, where R_{g_1} and R_{g_2} represent the resistances of gauges S_{g_1} and S_{g_2} respectively. (A similar arrangement is used for the strain gauges on the left fork.) The resistance values of R_{g_1} and R_{g_2} are each 120.0Ω when the sensors are unstrained. The resistance values of R_{g_1} and R_{g_2} are 119.6Ω and 120.8Ω respectively when the fork is holding the maximum load. Resistors R_2 and R_3 both have a value of 120Ω .

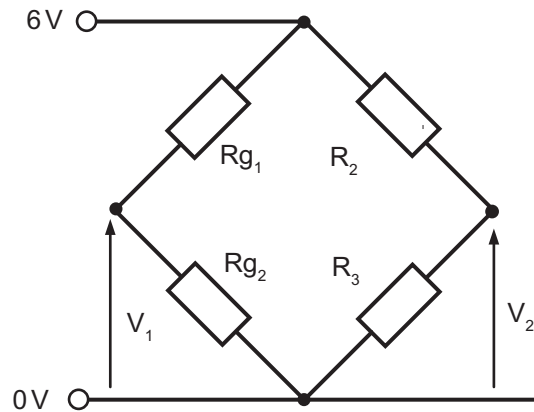

Fig. 2(c)

- (i) State the name of the circuit arrangement shown in **Fig. 2(c)**. [1]
- (ii) Calculate the voltages V_1 and V_2 in **Fig. 2(c)** when the maximum load is applied to a fork. [3]
- (iii) The circuit shown in **Fig. 2(c)** is to be connected to a differential amplifier having an output voltage of $2.25V$ where $V_o = (R_F/R_1)(V_2 - V_1)$. Draw the differential amplifier choosing suitable values for the feedback resistors R_F and R_1 to achieve the gain required and show how the amplifier would be connected to the circuit in **Fig. 2(c)**. [6]

- (d) The output from the amplifier circuit described in question 2(c)(iii) is to be used to drive a cab mounted LED bar graph display for the right fork with a similar circuit for the left fork. The bar graph displays are shown in Fig. 2(d) where all bars on the displays illuminate green except the top 3 bars which illuminate red to indicate that the forks are being overloaded.

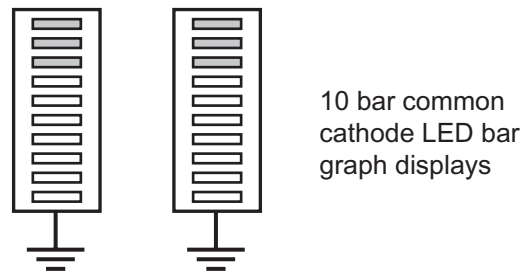

Fig. 2(d)

On the blank pro forma provided (answer number 2(d)) use annotated circuit diagrams to produce viable designs for each of the following points:

- Design a circuit based on bar graph display drivers that will operate the bar graph displays shown in Fig. 2(d) for both the left and right forks using the output from the respective differential amplifiers. [4]
- Design a circuit that will switch on a buzzer if either of the bar graph displays shown in Fig. 2(d) in the forklift cab unit indicate maximum overloading on the respective fork (i.e. when the 10th segment of either display is illuminated). The buzzer should turn on and off at 0.25 second intervals until the load on the appropriate fork is reduced or rebalanced. (The loading on each fork must be checked at least 2 times per second.) [6]

Answer **either** the **two** questions in Section A **or** the **two** questions in Section B.

Section B

Mechanical and Pneumatic Control systems

- 3 **Fig. 3(a)** shows a diagram of an off-road quad bike. Behind the guards and casing the clutch, cam, linkages, chain and sprocket, gears, couplings and shafts combine to provide an exciting product.

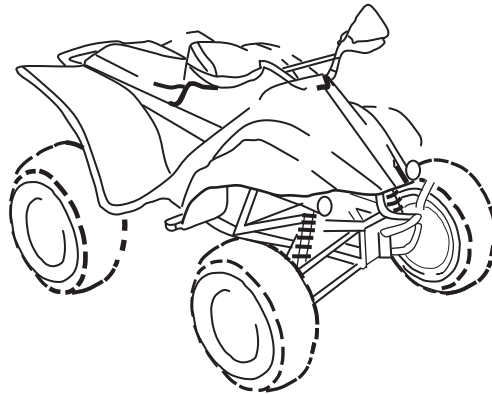

Fig. 3(a)

- (a) (i) Briefly describe the main difference between static and dynamic friction in relation to force. [2]

Fig. 3(b) shows a prototype gearing arrangement that could be used to provide the appropriate reduction from the drive shaft of the quad through the speedometer cable to the distance display.

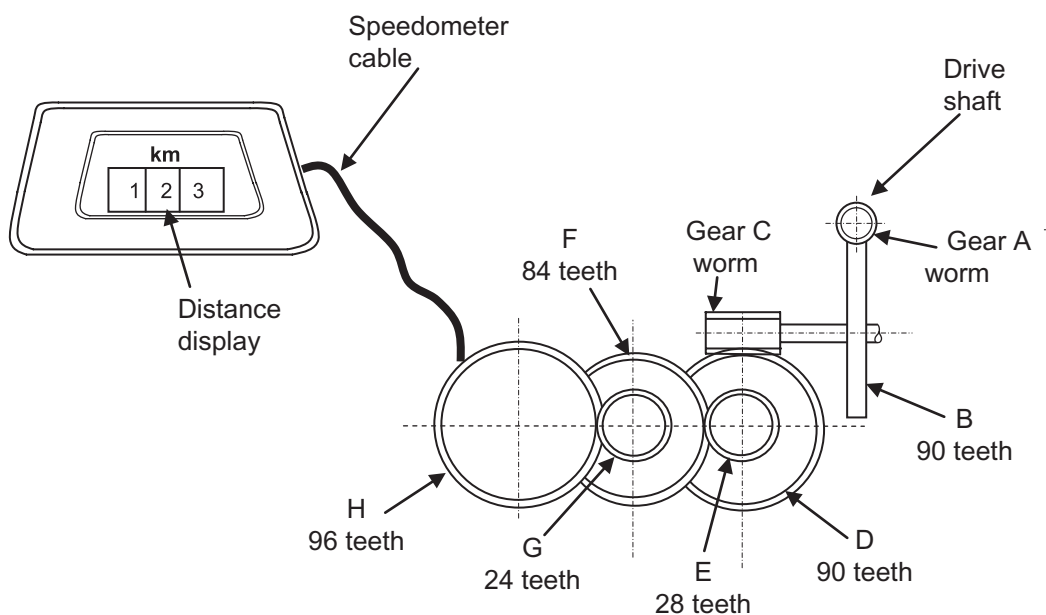

Fig. 3(b)

(ii) Calculate the velocity ratio from gear **A** to gear **H**. [2]

(iii) Calculate the input torque from the shaft containing gear **A** if the output torque on the shaft containing the worm **H** is 486 Nm. [3]

(b) Using an annotated sketch draw a centrifugal clutch which could be used to transmit rotation through to the rear wheels of the quad. [4]

(c) The wheel assembly of the quad uses a bearing as shown in **Fig. 3(c)** below. Discuss the merits of using each of the following bearings; plain, roller element or thrust. Select an appropriate bearing for the wheel and justify your choice. [5]

Quality of written communication [4]

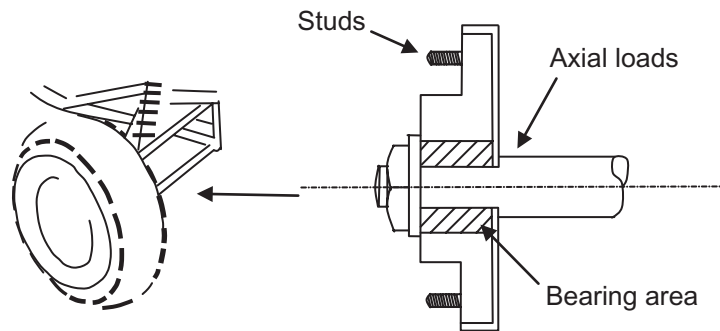

Fig. 3(c)

(d) Cams are used in quad engines to open and close valves which control the flow of fuel and air into the combustion chamber.

(i) The profile of the cam is determined by a performance/displacement diagram. On the pro forma provided (answer number **3(d)(i)**) complete the performance/displacement diagram which would accurately produce the following motion:

- 0–180 degrees rise 40 mm with simple harmonic motion
- 180–270 degrees rise 20 mm with uniform velocity
- 270–360 degrees fall 60 mm with uniform acceleration and retardation

[5]

(ii) Fig. 3(d)(ii) below shows a new performance/displacement diagram.

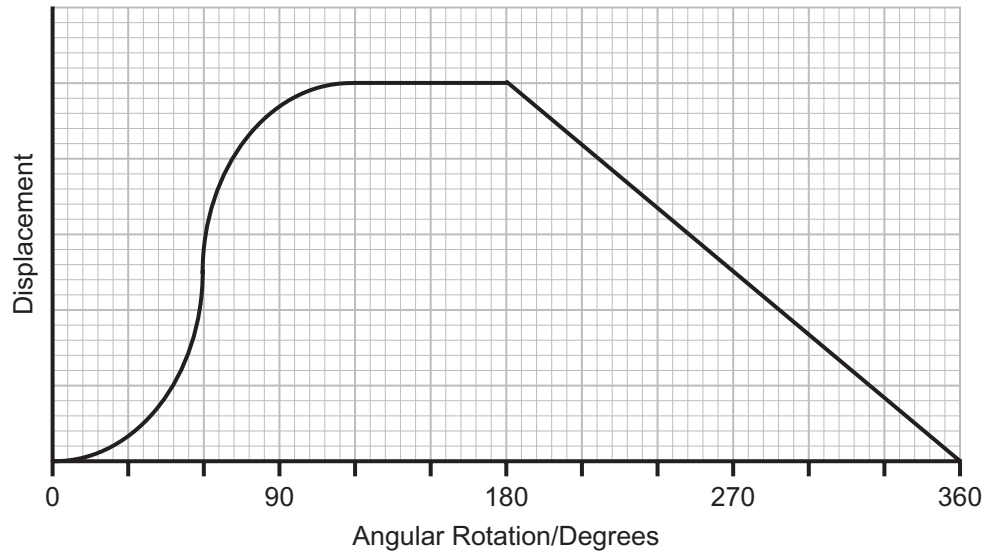

Fig. 3(d)(ii)

On the pro forma provided (answer number **3(d)(ii)**) using an appropriate drawing technique, construct a cam profile which would accurately follow the performance/displacement diagram. The line of stroke of the follower is in line with the centre of the cam. The follower is a point follower and the cam rotates in an anti-clockwise rotation. [5]

(e) **Fig. 3(e)(i)** and **(ii)** shows two improvements required for the quad. In **Fig. 3(e)(i)** the operator needs to tension the straps in order to secure the quad on a trailer during transit and in **Fig. 3(e)(ii)** problems developed as shaft B which is driven by shaft A was unable to make slight axial movements to accommodate changing conditions.

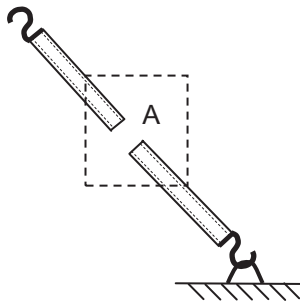

Fig. 3(e)(i)

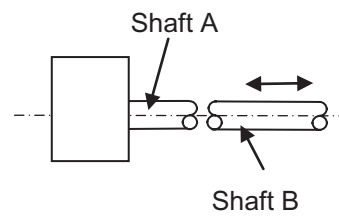

Fig. 3(e)(ii)

In your answer booklet design, draw and annotate a mechanical system which would achieve each of the following requirements:

- A means of allowing the operator to increase or decrease the tension on the straps at A in order to secure the quad firmly on a trailer. [5]
- A means of providing a positive drive through the two shafts A and B while allowing shaft B to have small axial movements (show how your design is attached to the shafts). [5]

4 Vacuum pumps and vacuum lifting cups are used in many pneumatic industrial circuits.

(a) Briefly explain the main function of a vacuum pump and a vacuum lifting cup. [2]

(b) Fig. 4(a) below shows a circuit using a 5/3 valve (valve C) to control the movement of a double acting cylinder.

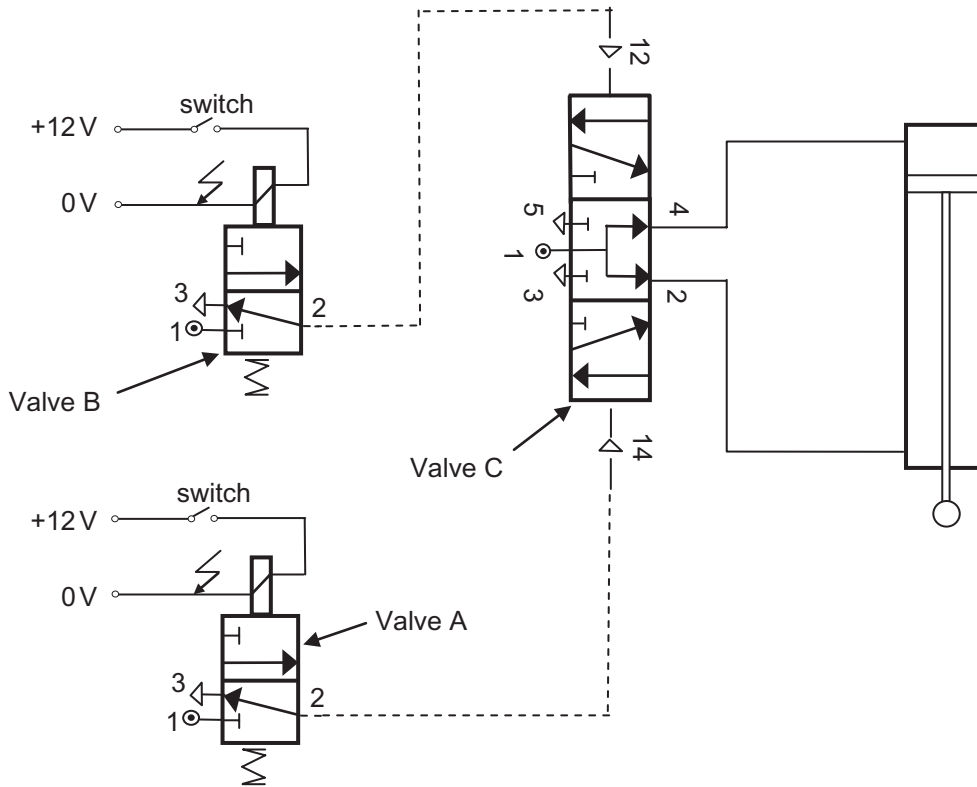

Fig. 4(a)

Explain how the circuit in Fig. 4(a) operates starting from when the switch is pressed to operate valve A. (Your answer should include a detailed explanation of the operation of valve C.) [5]

(c) **Fig. 4(b)** shows a pneumatic based work station used to cut lengths of tubular piping.

(i) The double acting cylinder A has a stroke length of 150 mm and is calculated to exert a force during the outstroke of 600 N. Calculate the work done on the outstroke if the 600 N force loses 20% through inefficiency. [2]

(ii) The double acting cylinders B1 and B2 operate with an air pressure of 0.4 N/mm^2 with each producing a force of 1004.8 N during the outstroke. It is intended to replace B1 and B2 with one large double acting cylinder. Calculate the piston radius of this replacement double acting cylinder which will operate at the same air pressure and produce the same force. Assume $\pi = 3.14$. [3]

(iii) The pneumatic based work station shown in **Fig. 4(b)** (refer to the pro forma answer number **4(c)(iii)** for the pneumatic circuit) is operated from the control panel with the following sequence:

- The START 3PV is operated and one side of the 5PV (valve Z) is selected by the operator. This will work in conjunction with valve X to provide air to Cylinder A to enable it to reciprocate and feed the pipe along the table. When the pipe makes contact with valve X this first sequence will stop.
- The operator then selects the other side of the 5PV (valve Z) and the sequence begins with Cylinder B1 and B2 outstroking to clamp the pipe.
- Cylinder C then outstrokes **slowly** to lower the blade and cut through the tubular pipe.
- Cylinder C instrokes **slowly** then sends a signal to make Cylinder D instroke which tilts the table to allow the cut pipe to slide down into the storage bin.
- Cylinder B1 and B2 instroke to release the pipe before Cylinder D outstrokes to return the table to the closed position to complete the sequence.

On the pro forma provided (answer number **4(c)(iii)**) draw a suitable sequential pneumatic circuit to achieve the desired sequence outlined above. [18]

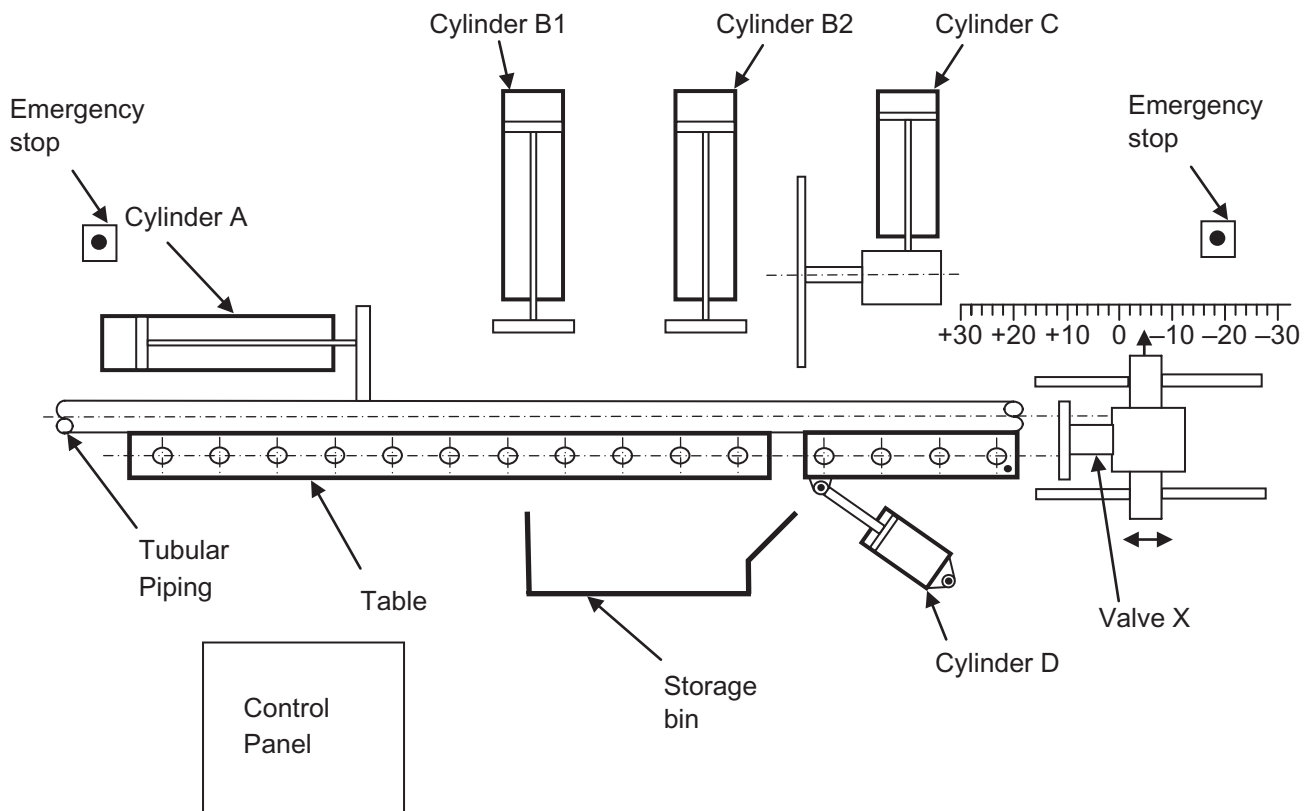

Fig. 4(b)

(d) On the pro forma provided (answer number 4(d)) design and draw:

- a pneumatic system which will stop the air supply to the 5PV controlling cylinder C if either of the emergency stop buttons are pressed during the operation. A manual reset will allow the air supply to return to the 5PV.
- a quick release mechanical system which will allow the operator to quickly release, move and re-position valve X along the guide in order to change the length at which the pipe will be cut.

[10]

THIS IS THE END OF THE QUESTION PAPER

Permission to reproduce all copyright material has been applied for.
In some cases, efforts to contact copyright holders may have been unsuccessful and CCEA
will be happy to rectify any omissions of acknowledgement in future if notified.

Question No. 1(d)(iii)

**ADVANCED LEVEL TECHNOLOGY AND DESIGN
Assessment Unit A2 1
2011**

Centre Number

71	
----	--

Candidate Number

--

**Pro forma answer page
(answer number 1(d)(iii))**

Question No. 2(d)

ADVANCED LEVEL TECHNOLOGY AND DESIGN
Assessment Unit A2 1
2011

Centre Number

71	
----	--

Candidate Number

--

Pro forma answer page
(answer number 2(d))

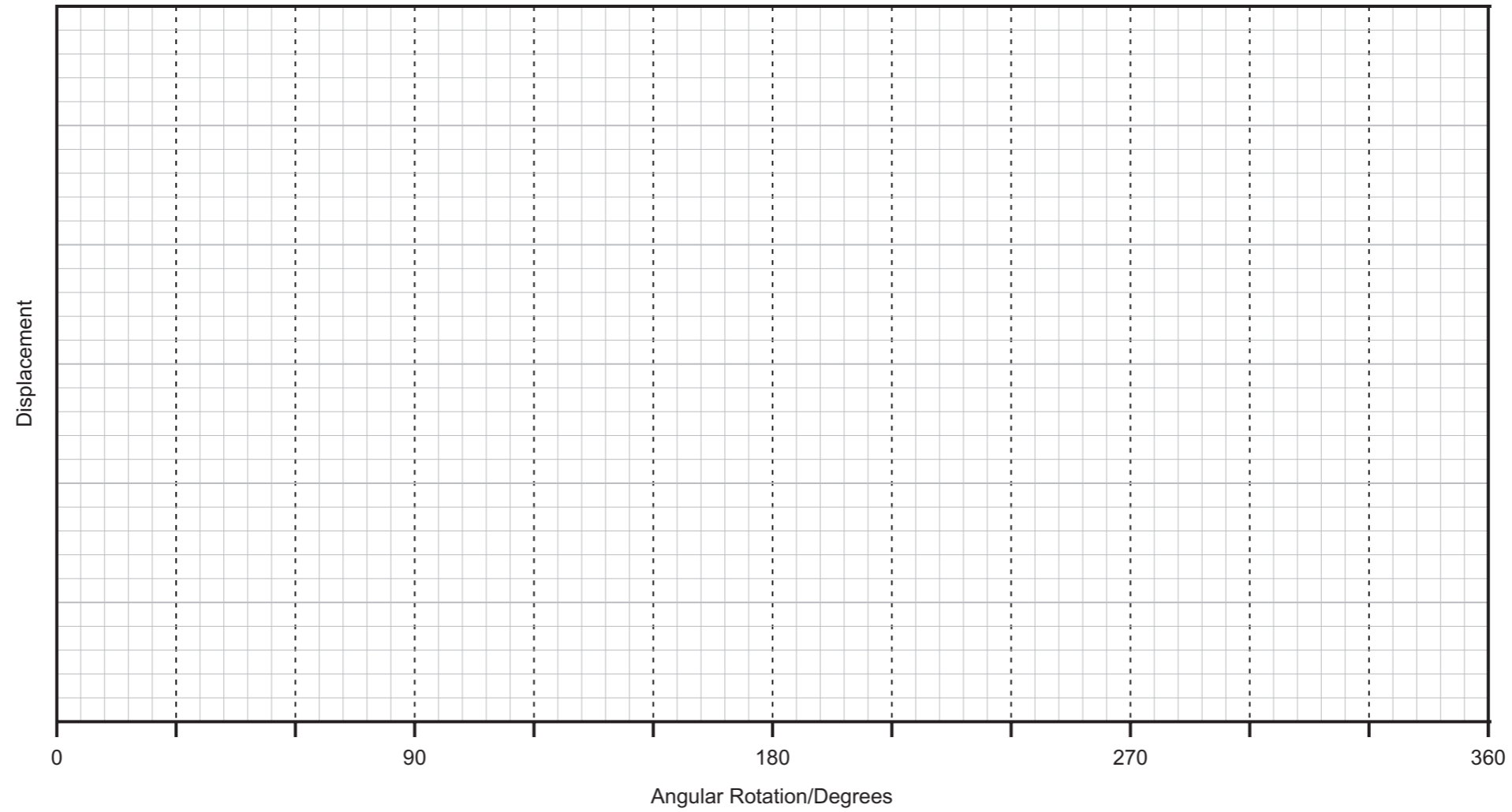

**Pro forma answer page
(answer number 3(d)(i))**

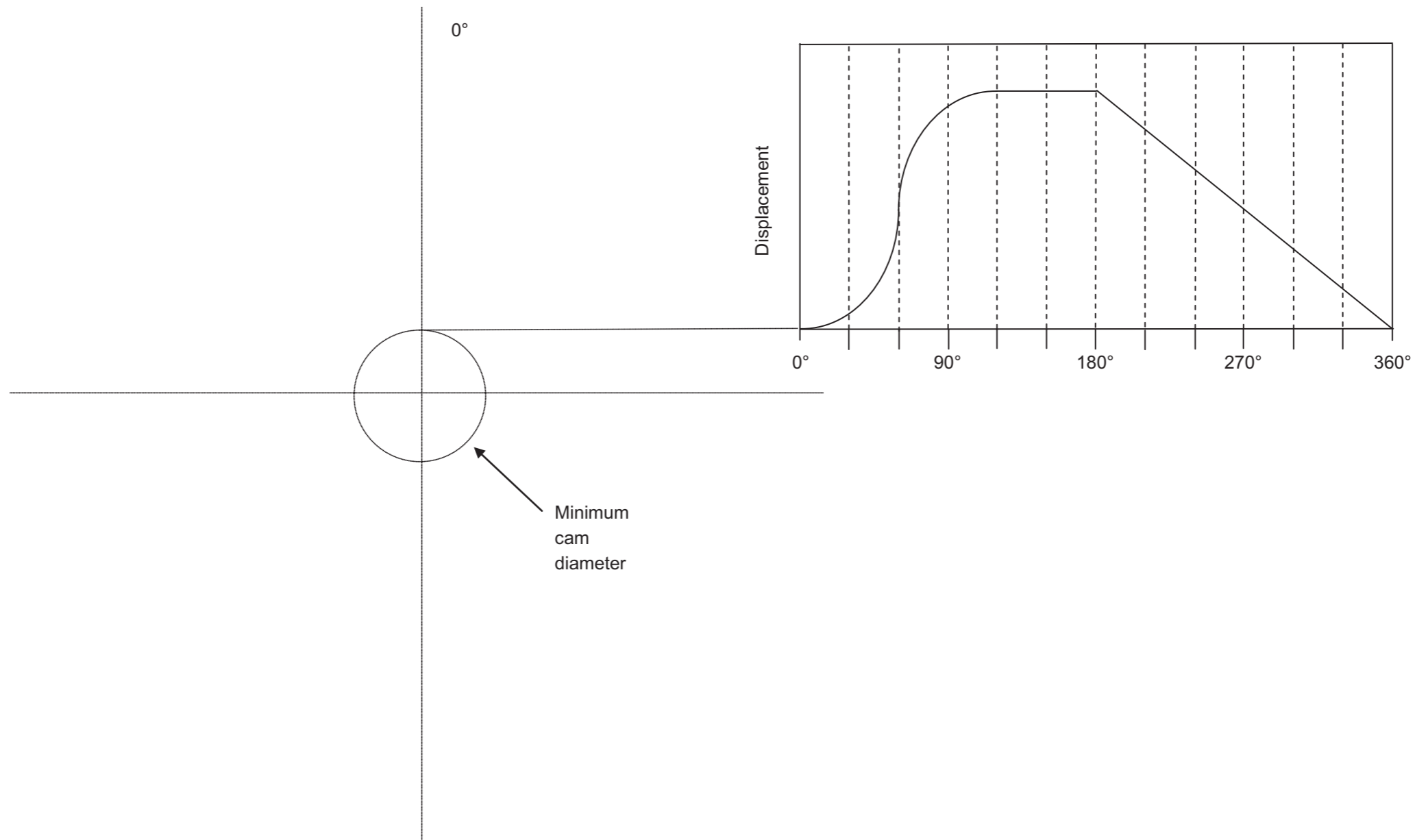

Pro forma answer page
(answer number 3(d)(ii))

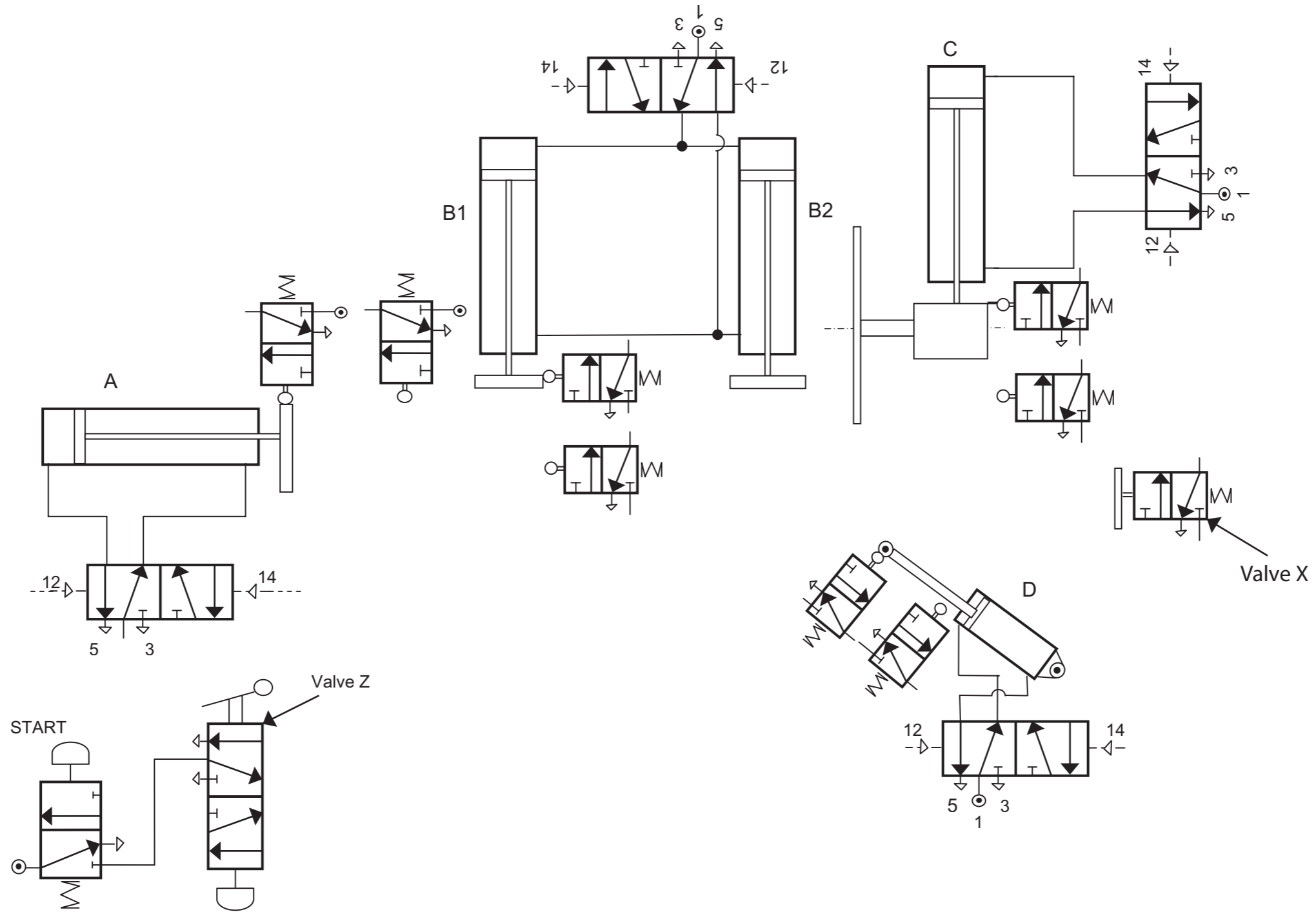

Pro forma answer page
 (answer number 4(c)(iii))

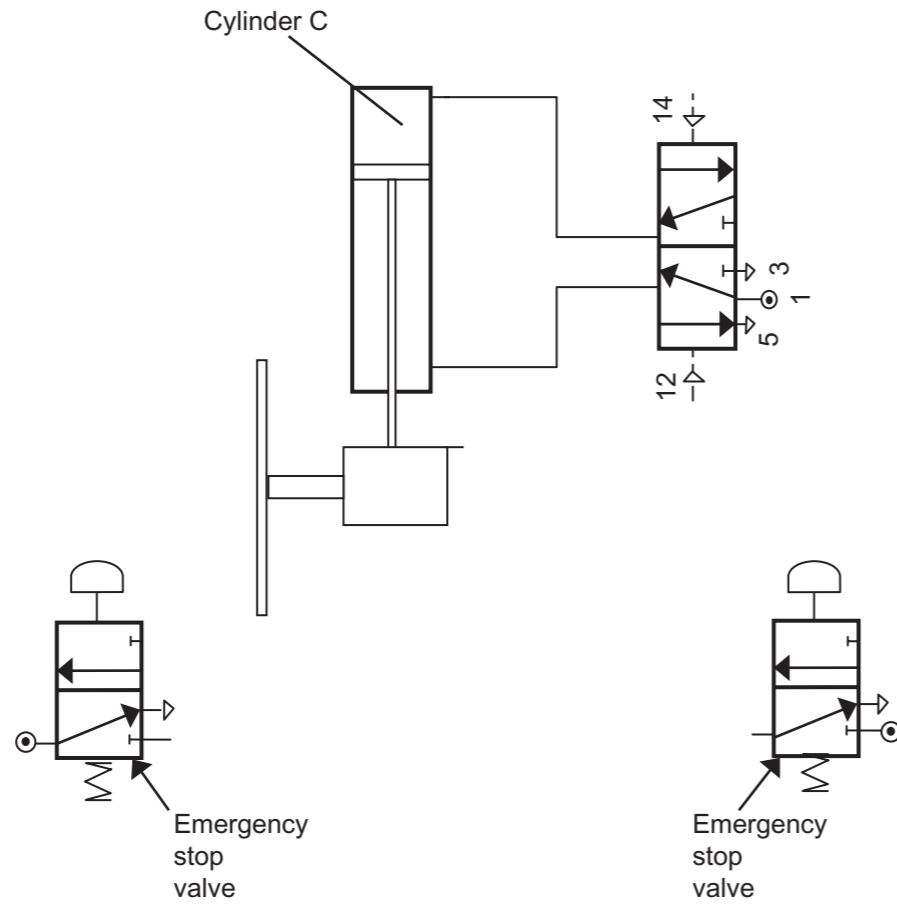

Bullet point 1

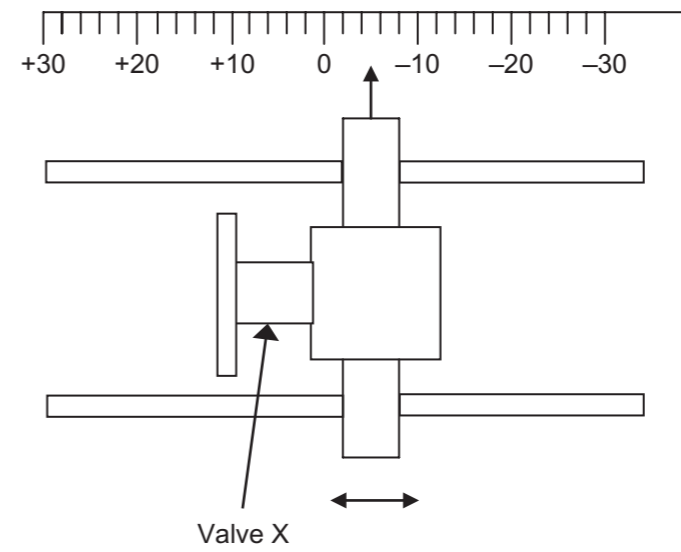

Bullet point 2

Pro forma answer page
 (answer number 4(d))