



Rewarding Learning

ADVANCED
General Certificate of Education
January 2011

Technology and Design

Assessment Unit A2 1

assessing

Systems and Control

[AV211]



WEDNESDAY 26 JANUARY, MORNING

TIME

2 hours.

INSTRUCTIONS TO CANDIDATES

Write your Centre Number and Candidate Number on the Answer Booklet provided and on the A3 pro forma answer pages provided.

Answer **either** the two questions in Section A **or** the two questions in Section B.

Answers to Questions **1(c)(iii)**, **4(c)** and **4(d)** should be made on the A3 pro forma answer pages provided.

At the conclusion of the examination, attach the A3 pro forma answer pages securely to the Answer Booklet with the treasury tag supplied.

INFORMATION FOR CANDIDATES

The total mark for this paper is 80, including a maximum of 4 marks for quality of written communication.

Marks for quality of written communication will be awarded for Questions **1(c)(ii)** and **3(e)**.

Figures in brackets printed down the right-hand side of the pages indicate the marks awarded to each question or part question.



Section A

Electronic/Microelectronic Systems

Answer both questions in this Section **or** both questions in Section B.

- 1 (a) A system to measure wind speed is shown in **Fig. 1(a)**. The system uses a turbine driven shaft which has a disc fixed to it. The rotating disc has a slot which is to be detected using a phototransistor. During tests it was found that the disc rotated at 10 revolutions per second when the wind speed was 20 kph.

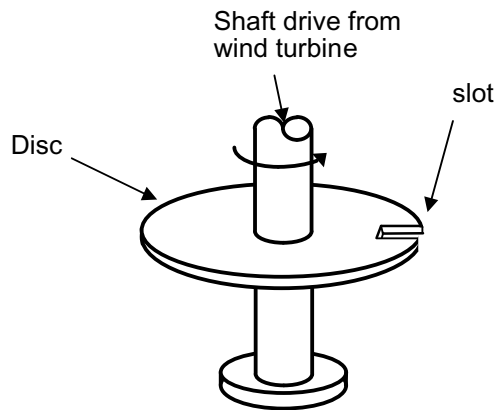

Fig. 1(a)

- (i) Draw the circuit symbol for a phototransistor. [1]
- (ii) Using a sketch show how a phototransistor in conjunction with additional components could be arranged to detect the slot each time the disc rotates. [3]
- (iii) Sketch a suitable alternative method of detecting each revolution of the disc and justify your choice. [3]

(b) A proposed circuit design for the wind speed indicator is shown in **Fig. 1(b)** where the pulses from the phototransistor are counted for a period of 10 seconds and the wind speed is indicated for 10 seconds by LED 7 segment displays.

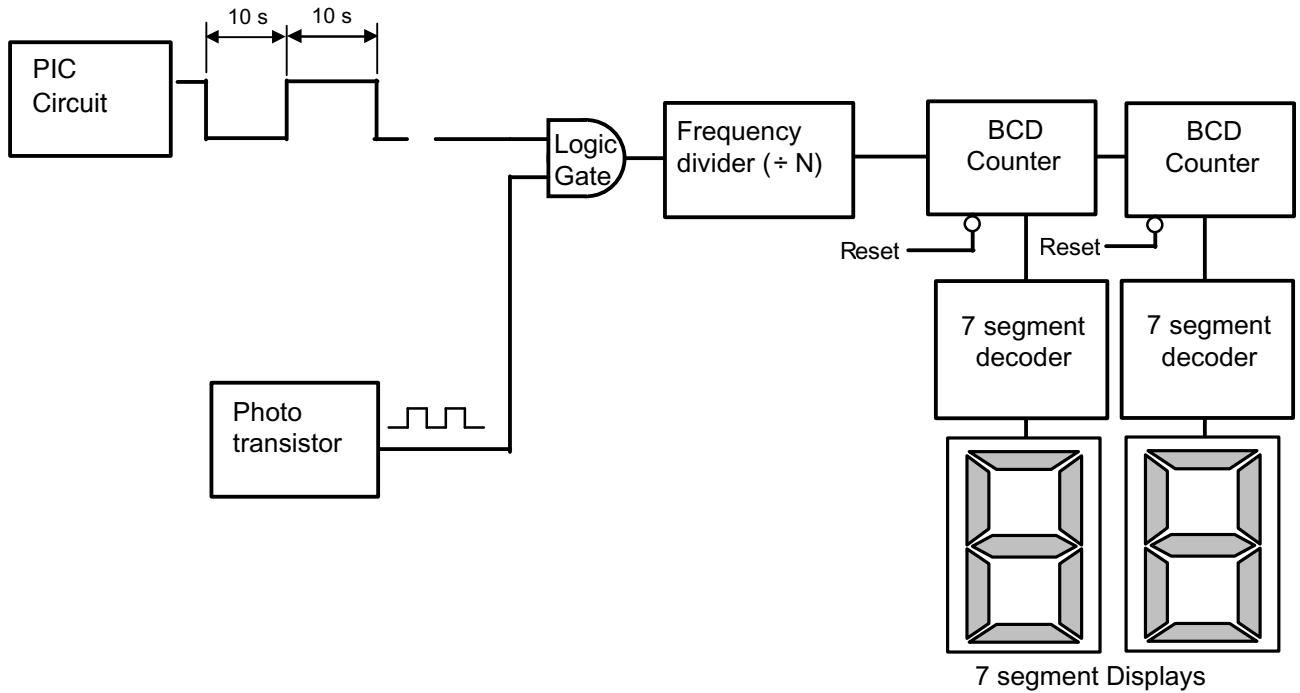

Fig. 1(b)

- (i) Explain the purpose of the logic gate in **Fig. 1(b)**. [2]
- (ii) Draw a suitable PIC flow chart that could be used to produce the required output for the PIC circuit shown in **Fig. 1(b)**. [3]
- (iii) Determine the number of pulses generated in the 10 second time period for a wind speed of 10 kph and then determine the factor this number must be divided by to display the wind speed in kph. [4]
- (c) (i) Design a frequency divider circuit based on the binary counter shown in **Fig. 1(c)** that fulfils the requirements of (b)(iii). Assume that Qa is the Least Significant Bit (LSB). [5]

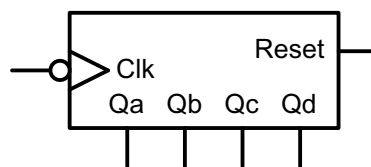

Fig. 1(c)

- (ii) LCD displays can be used as an alternative to LED type displays. Compare **two** features of each type of display. Suggest two examples, one where an LCD display is preferred to an LED display and one where an LED display is preferred to an LCD display. Justify the particular choice in each case. [5]

QWC [4]

- (iii) Two modifications have been suggested for the wind speed circuit shown in **Fig. 1(b)**. Using electronic circuit diagrams on the blank pro forma provided (**answer number 1(c)(iii)**), show how the following design modifications could be made.

- After one complete cycle of the timing circuit the BCD counters have to be reset before the next measurement of wind speed has to be displayed. [4]
- It was discovered that pulses from the phototransistor were not accurate digital pulses with a 'clean' logic 1 and logic 0 voltage level. Design a circuit that will be triggered by the phototransistor to produce a digital pulse of a time period of 10ms, which can be used to increment the counter each time the slot in the rotating disc is detected. [6]

- 2 An industrial printing process used to apply a reflective coating to metal panels is shown in **Fig. 2(a)**. The process consists of an eight stage sequence controlled by an output from a 3 bit binary counter with outputs A, B and C, where A is the least significant bit. A signal is required to control a 24VDC motor at stages 3, 4, 6 and 7 where a high output from the logic circuit shown in **Fig. 2(a)** will activate and release the pressure plate.

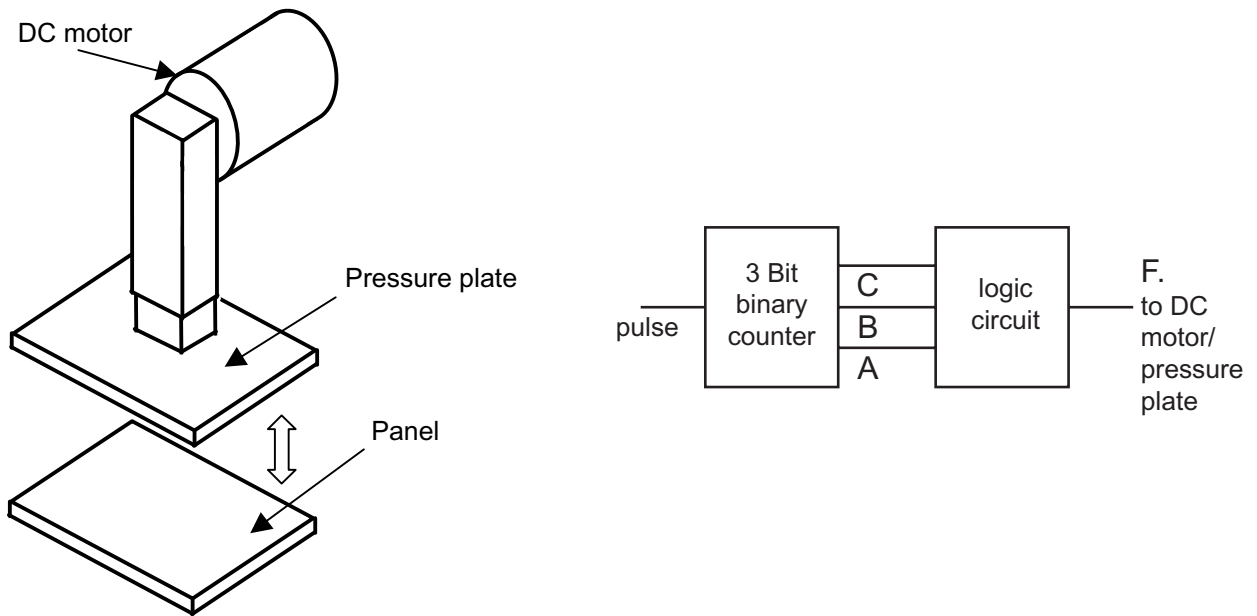

Fig. 2(a)

- (a) (i) Draw a truth table for the logic circuit that controls the pressure plate assuming that the output of the logic circuit is F. [4]
- (ii) Using a Karnaugh Map, deduce a minimised expression for the output F. [4]
- (iii) Draw a logic circuit that would produce the required output F. [2]
- (iv) Describe 2 advantages other than cost of using a DC motor in preference to a stepper motor for the application shown in **Fig. 2(a)**. [4]

(b) After the 8 stage printing process has been completed, the panels in **Fig. 2(a)** are to be tested to determine the quality of the printed reflective coating. **Fig. 2(b)** shows a prototype design. It consists of a housed light source directed at the test panel and an LDR in a housing to detect the reflected light. **Fig. 2(b)** also shows how the LDR is arranged in a voltage divider circuit.

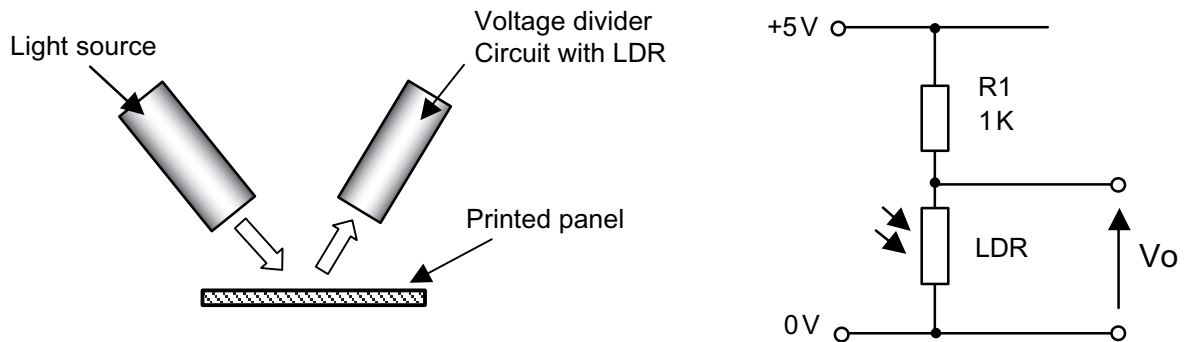

Fig. 2(b)

- (i) A light dependent resistor (LDR) can be used as the basis for a sensor to measure the reflected light. State the main physical property of the LDR that makes it useful for this application. [1]
- (ii) The resistance of the LDR shown in **Fig. 2(b)** can vary from $80\ \Omega$ to $8\ \text{k}\Omega$. Calculate the corresponding values for V_o . [2]
- (iii) Calculate the total power dissipated by the voltage divider shown in **Fig. 2(b)** if the resistance of the LDR is $80\ \Omega$. [2]

- (c) (i) When testing the reflective coatings on the finished panels, it was found that the output from the Voltage divider V_o in **Fig. 2(b)** was 2.49 volts when the reflective coating was excellent and 2.5 volts if the coating was unsatisfactory.

The voltage V_o is to be displayed using a 5V voltmeter as shown in **Fig. 2(c)**. A maximum reading on the voltmeter should represent an excellent reflective coating and 0V should represent an unsatisfactory reflective coating. The voltage divider in **Fig. 2(b)** is incorporated into a wheatstone bridge arrangement as shown in **Fig. 2(c)**. An amplification system is therefore required. Determine the required gain of the amplifier system. [3]

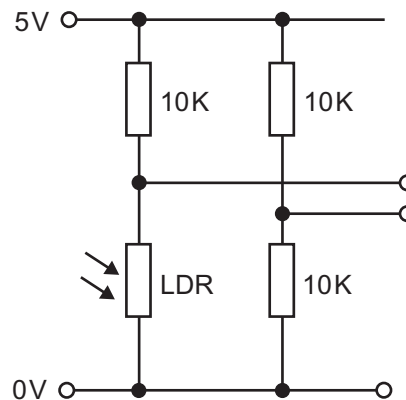
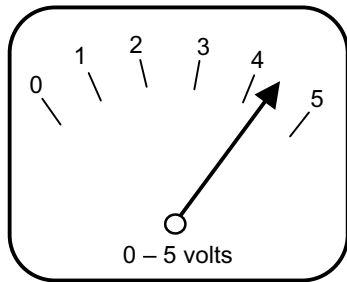

Fig. 2(c)

- (ii) Design an amplification system based on op-amps that will have the required gain from (c)(i) given that the gains of inverting and difference amplifiers are given by $-R_f/R_1$ and $R_f/R_1(V_2 - V_1)$ respectively where resistor R_f is the feedback resistor in each case, and V_2 and V_1 are the input voltages to the differential amplifier. [6]
- (iii) The testing system shown in **Fig. 2(b)** and associated amplifier and meter from (c)(i) and (c)(ii) can be analysed and represented as block diagram showing the input, control and output sub systems. Draw the complete block diagram and state if the system is on/off or continuous. [2]
- (d) The motor driven pressure plate in **Fig. 2(b)** is controlled by a logic signal where a logic 1 will cause the 24VDC motor to switch on for 2 seconds to apply pressure to the panel before reversing for 2 seconds to retract the plate. The area around the pressure plate is guarded by 2 microswitch activated safety guards. Design a suitable PIC based circuit and flow chart program to achieve the following;
- Drive the 24VDC motor to make the pressure plate activate and retract when it receives a logic 1 from logic control circuit [3]
 - Prevent the DC motor from operating if either of the safety guards are opened. [2]
 - Ensure the motor remains off when the plate has fully retracted. [2]
 - Sound a 12V buzzer and illuminate a 12V bulb if either of the safety guards have been opened. [3]

Assume that the PIC and logic circuits operate at 5 volts.

BLANK PAGE

Section B

Mechanical and Pneumatic Control systems

Answer both questions in this Section **or** both questions in Section A.

- 3 (a) Using an annotated sketch briefly explain what is meant by the term pitch point as associated with gears. [2]

- (b) Fig. 3(a) shows a prototype test rig used to investigate the suitability of different gear train combinations for a gearbox and the amount of abrasion taken place with carbon fibre pads used on disc and drum brakes. On the right hand side a disc brake system is positioned in the housing and on the left side a drum brake system.

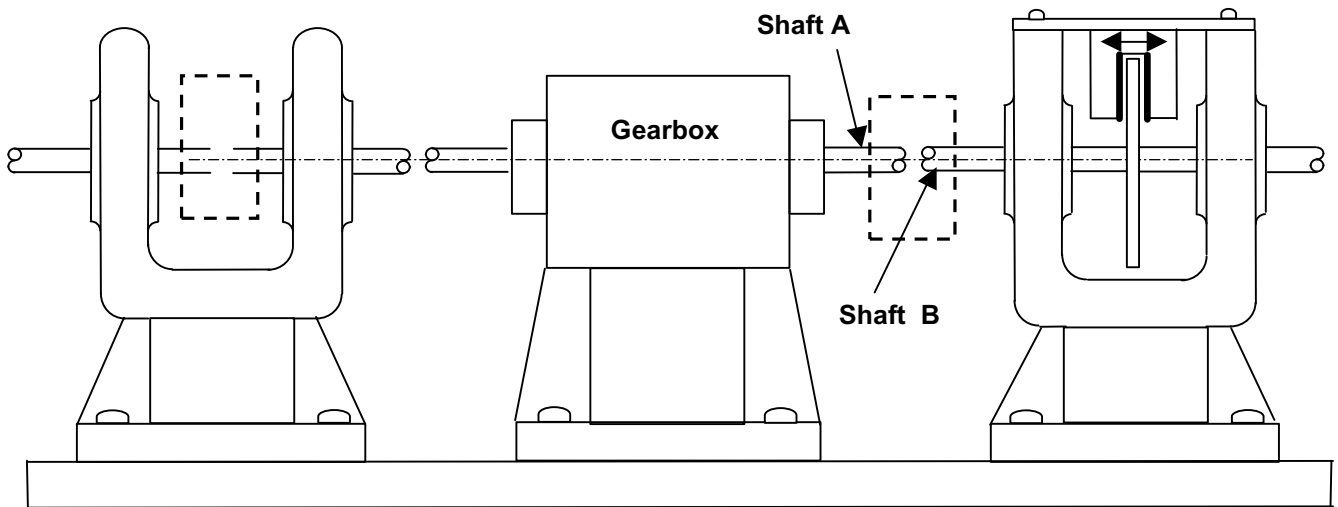

Fig. 3(a)

- (i) Using an annotated sketch name and draw a suitable coupling which will transmit rotary motion between the two aligned shafts, **A** and **B**. Show how the coupling is attached to the shafts. [4]
- (ii) Using an annotated sketch outline the main features of a drum brake. [4]

(c) **Fig. 3(b)** below shows a compound gear train to be used for initial testing in the gearbox.

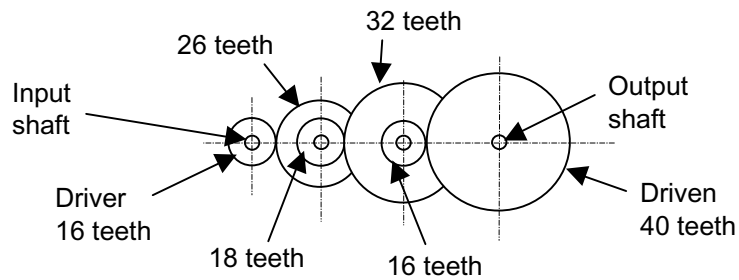

Fig. 3(b)

(i) Calculate the output torque for the compound gear train shown in **Fig. 3(b)** if the input torque is 180 N m. [3]

(ii) Assuming no power loss due to friction, calculate the power from the output shaft if it rotates at 240 rev/min (rpm). [3]

(d) **Fig. 3(c)** below shows a half sectioned view of the shaft and housing which supports the brake system. In order to reduce friction a modification to the design of the housing needs to be made to accommodate a bearing with a rolling element.

Using an annotated sketch draw a roller bearing to support the shaft and brake system as shown. Your annotated sketch should include suitable changes to the housing to accommodate and secure the bearing while making provision for lubrication. [5]

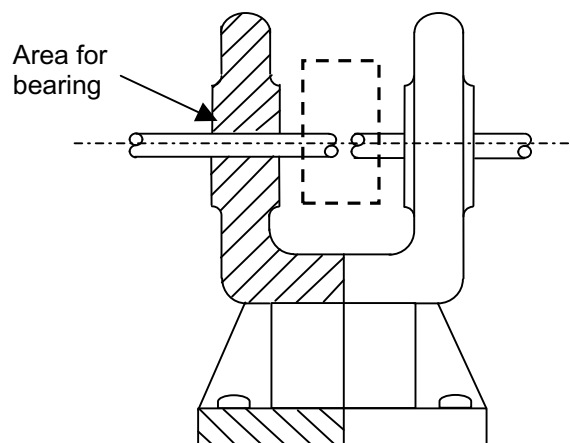

Fig. 3(c)

(e) **Fig. 3(d)** below shows two views of the casing for the gearbox. This casing can be disassembled by removing the 8 bolts and the side plate along the line X-X in order to insert shafts and gears. Describe and justify the choice of a suitable seal and housing for the following:

- Side plate to the main gearbox housing
- Output shafts to the main gearbox housing

[5]

QWC [4]

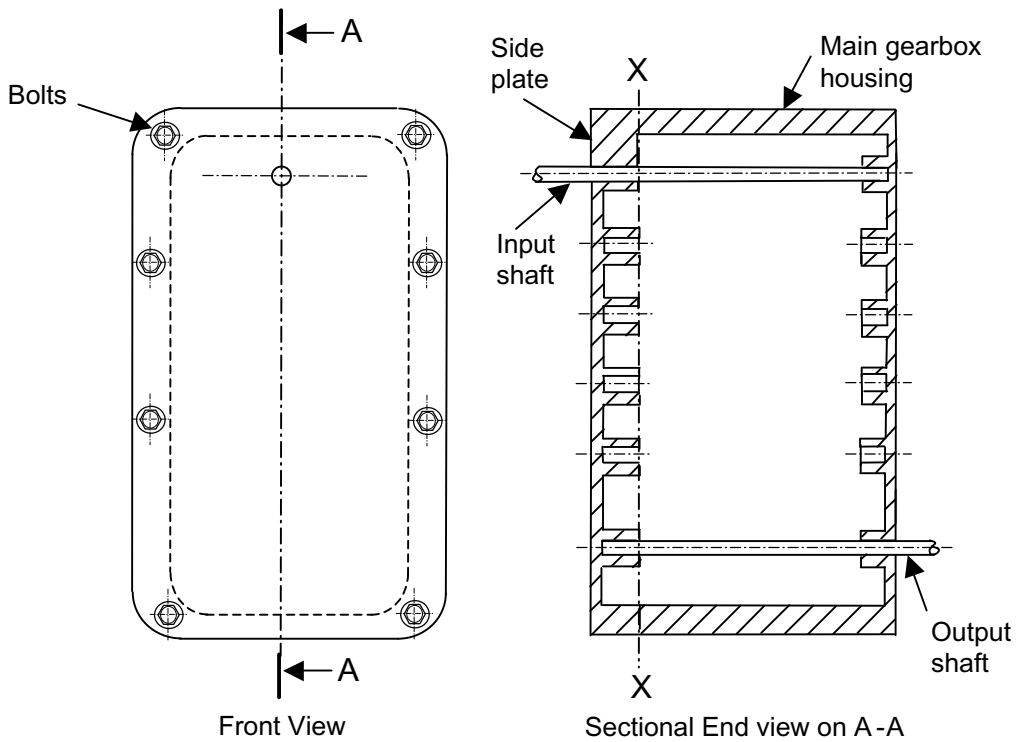

Fig. 3(d)

(f) **Fig. 3(e)** shows a sectional view of the gearbox that will be used to drive the test rig shown in **Fig. 3(a)**. If the input shaft rotates at 7,680 rpm:

- using the gearbox in **Fig. 3(e)** calculate and select gears with teeth between 20 and 100 that will provide an output speed of 240 rpm. **(State clearly the number of teeth for each of the gears on shafts A, B, C, D and E.)** [6]
- Then with the minimum number of additional gears to the gearbox show how you would increase the output speed by one third. **(State clearly the output speed and the number of teeth for each additional gear used.)** [4]

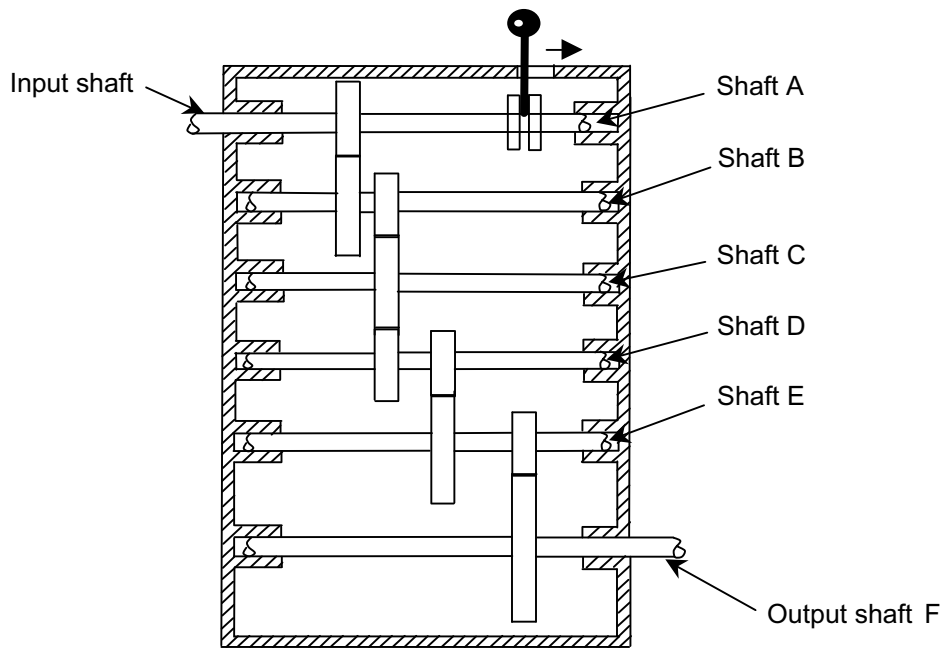

Fig. 3(e)

4 (a) Open and closed loop systems are used in pneumatic circuits.

Briefly distinguish between open and closed loop systems.

[2]

(b) Fig. 4(a) below shows a circuit used to control the movement of a double acting cylinder for stamping boxes.

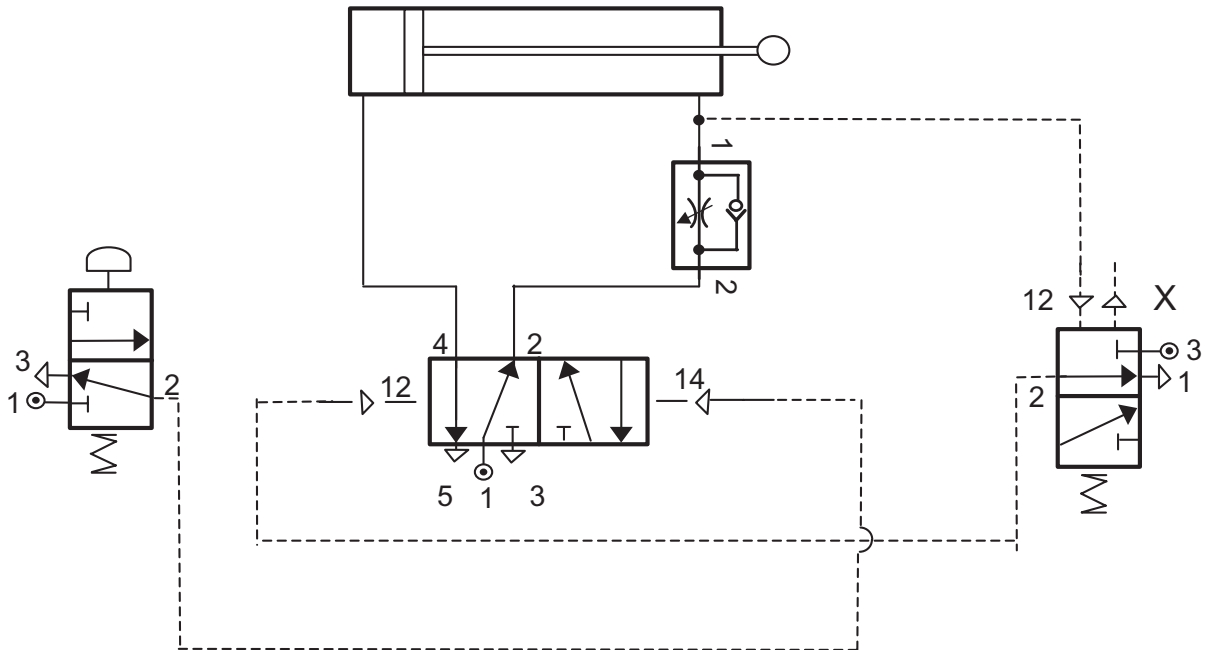

Fig. 4(a)

(i) Explain how the circuit in Fig. 4(a) operates starting from when the push button 3PV is pressed. (Your answer should include a detailed explanation of the operation of component X.)

[4]

(ii) In order to determine a suitable compressor the air consumption for the double acting cylinder in Fig. 4(b) is to be calculated. Using the data below calculate the air consumption for the cylinder in litres per minute.

Diameter (D) = 80 mm
 Piston rod diameter (d) = 10 mm
 Stroke (S) = 150 mm
 Gauge pressure = 4 bar
 Cylinder cycles = 20 per minute
 Atmospheric pressure = 1 bar
 Please assume $\pi = 3.14$.

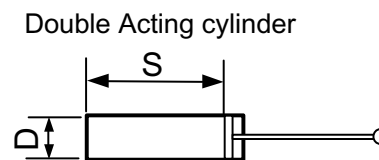

Fig. 4 (b)

[6]

(c) Fig. 4(c) shows a pneumatic based work station used to manufacture batches of acrylic moulds. The sequence is as follows:

- An acrylic sheet is manually positioned by the operator and the guard lowered to a closed position.
- On the control panel the operator must press two valves at the same time to start the sequence. This sequence cannot begin unless the guard is closed.
- Cylinder A1 and A2 go negative to clamp the acrylic.
- Cylinder B goes positive slowly, has a time delay in order to heat the acrylic before going negative.
- Cylinder C goes positive forcing the acrylic to take the profile of the mould.
- When the acrylic fully covers the two air ducts cylinder C will go negative.
- Cylinder A1 and A2 go positive to release the clamp and allow the acrylic to be removed.
- An emergency stop button is included. When pressed it will stop all movement of valves and cylinders.

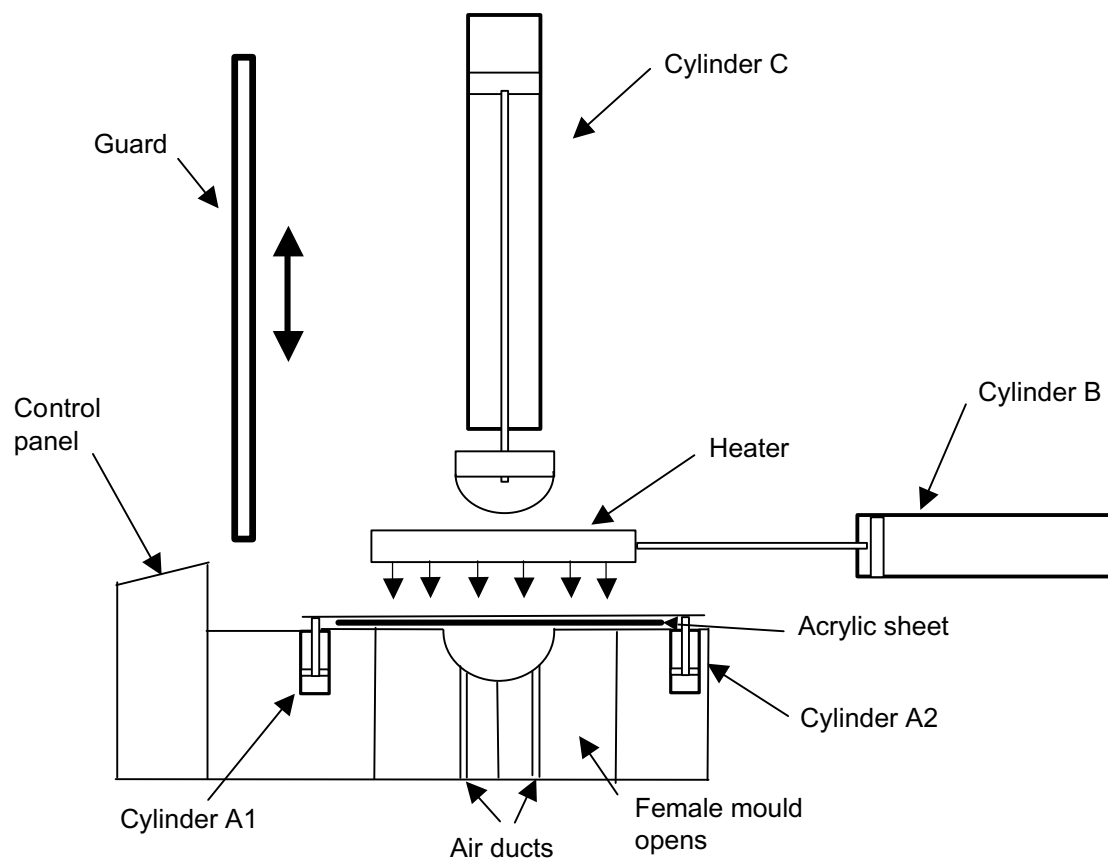

Fig. 4(c)

On the pro forma provided (**answer number 4(c)**) draw a suitable sequential pneumatic circuit to achieve the desired sequence outlined above.

[18]

(d) On the pro forma provided (**answer number 4(d)**) design and draw a pneumatic system which will:

- Return cylinder C to the negative position if the guard is accidentally lifted at any stage of the operation. [5]

- Use the minimum number of pneumatic components to release the newly formed acrylic mould by momentarily opening the female mould after A1 and A2 go positive. [5]

Permission to reproduce all copyright material has been applied for.
In some cases, efforts to contact copyright holders may have been unsuccessful and CCEA
will be happy to rectify any omissions of acknowledgement in future if notified.