



Rewarding Learning

ADVANCED
General Certificate of Education
January 2010

Technology and Design

Assessment Unit A2 1

assessing

Systems and Control

[AV211]



WEDNESDAY 27 JANUARY, MORNING

TIME

2 hours

INSTRUCTIONS TO CANDIDATES

Write your Centre Number and Candidate Number on the Answer Booklet provided and on the A3 pro forma answer pages provided.

Answer **EITHER** the two questions in Section A **OR** the two questions in Section B.

Answers to Questions **1(c)**, **3(b)(iv)**, **4(a)(ii)**, **4(b)** and **4(c)** should be made on the A3 pro forma answer pages provided.

At the conclusion of the examination, attach the A3 pro forma answer pages securely to the Answer Booklet with the treasury tag supplied.

INFORMATION FOR CANDIDATES

The total mark for this paper is 80, including a maximum of 4 marks for quality of written communication.

Marks for quality of written communication will be awarded for questions **1(b)(iv)** and **3(a)(iii)**. Figures in brackets printed down the right-hand side of the pages indicate the marks awarded to each question or part question.

Section A

Electronic/Microelectronic Systems

Answer **both** questions in this section.

- 1 (a) A system to indicate the level of grain in a storage tank is shown in **Fig. 1(a)**. The grain in the tank is detected by three sensors S1, S2, and S3. Each sensor outputs a logic '1' when the grain pushes against it. An LED 7-segment display is then used to indicate the level. The display and corresponding grain levels are shown in the table in **Fig. 1(a)**.

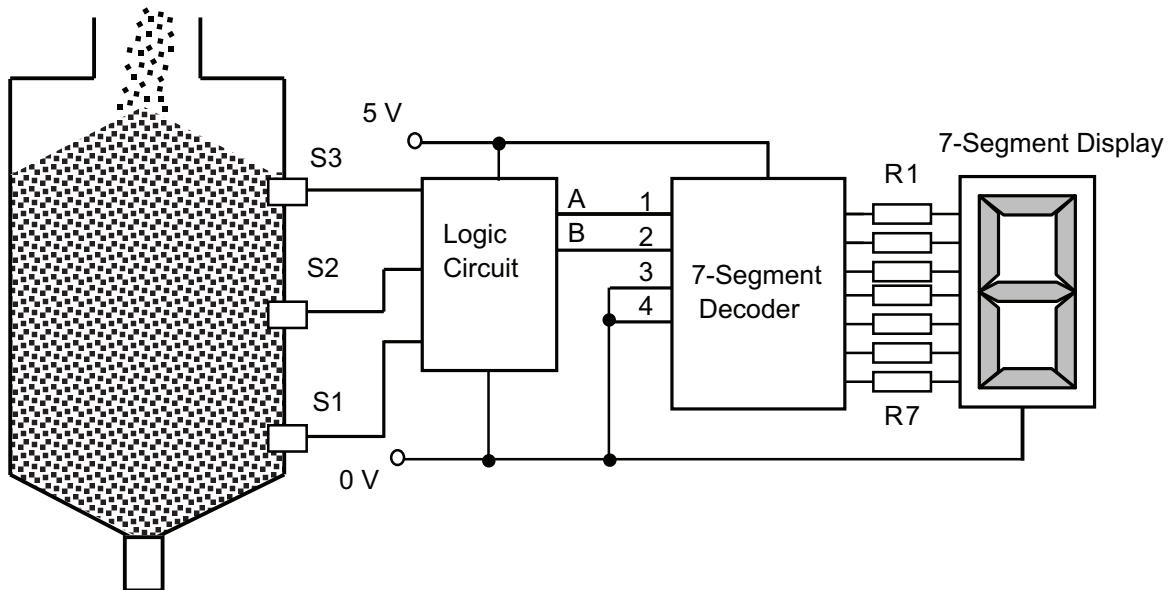

Grain level	Display
below S1	0
between S1 and S2	1
between S2 and S3	2
above S3	3

Fig. 1(a)

- (i) Briefly explain the purpose of the resistors R1–R7 in the circuit shown in **Fig. 1(a)**. [1]
- (ii) Seven-segment displays are available as common anode or common cathode types. Explain the difference between these displays and identify the specific type shown in **Fig. 1(a)**. [2]

- (iii) Construct a truth table showing the logic signals from the sensors and the corresponding outputs A and B from the logic circuit shown in **Fig. 1(a)**. [3]
- (iv) Deduce logic expressions for A and B. [4]
- (v) Implement these expressions with appropriate logic gates. [2]
- (vi) Explain why the inputs 3 and 4 to the decoder are connected as shown in **Fig. 1(a)**. [2]

- (b) The system shown in **Fig. 1(a)** is to be altered to incorporate a weighing mechanism. This mechanism uses a strain gauge which is to be attached to the bottom of the tank. The proposed circuit for this is shown in **Fig. 1(b)**. A digital voltmeter, connected to the output from this circuit, will then display a number which will represent the approximate weight of the grain.

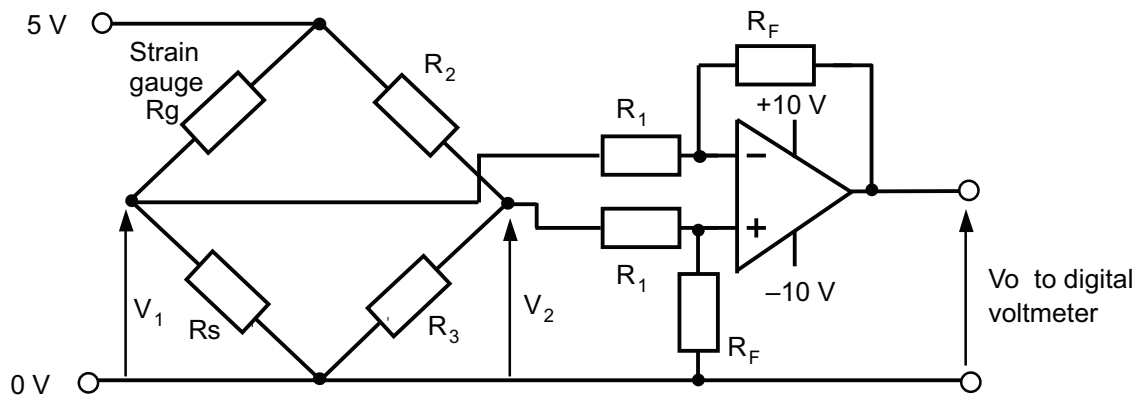

Fig. 1(b)

- (i) With the aid of an annotated sketch, explain the structure of a typical strain gauge. Clearly label the passive and active axes. [2]
- (ii) The strain gauge resistance is 120.0Ω when not strained. Find the value of voltage V_1 when the resistance of the gauge is increased by 1% due to strain where $R_s = R_2 = R_3 = 120.0\Omega$. [2]
- (iii) The Op amp in **Fig. 1(b)** is connected as a difference amplifier having an output voltage, $V_o = (R_F/R_1)(V_2 - V_1)$. The output voltage V_o is to range from 0V to +0.2V as the gauge resistance is increased by 1%.

Determine,

- the gain of the difference amplifier to provide the required output [1]
 - suitable values for R_F and R_1 , where the resistor values should be at least $10\text{ k}\Omega$ [2]
- (iv) Before the circuit shown in **Fig. 1(b)** could be used commercially, the safety of the system must be considered. Identify the main safety issues associated with the use of electronic and microelectronic systems and justify the procedures used to ensure such systems are safe. [5]

Quality of written communication [4]

- (c) The sensors S1, S2 and S3 on the grain storage tank pressure in **Fig. 1(a)** could incorporate a microswitch.
- (i) On the blank pro forma provided (answer number **1(c)**), design a sensor which could be used for S1, S2 or S3 based on a microswitch. Indicate how the grain would activate the sensor and how the sensor could be attached to the tank. [4]
- (ii) The circuit shown in **Fig. 1(a)** is to be modified so that the 7-segment display flashes off and on when the level of grain in the tank reaches S3. On the blank pro forma provided (answer number **1(c)**), design a circuit to achieve this. [6]

- 2 (a) A sliding type variable resistor with a $10\text{k}\Omega$ linear resistance is arranged as shown in Fig. 2(a). The voltage V_o is measured between the sliding wiper at terminal C and terminal B. The wiper can move a total distance of 60 mm from A to B.
- (i) Sketch a graph of how the voltage V_o varies as the wiper is moved from terminal A to terminal B in Fig. 2(a). [3]
- (ii) Calculate V_o when the wiper is in the position shown in Fig. 2(a). [3]

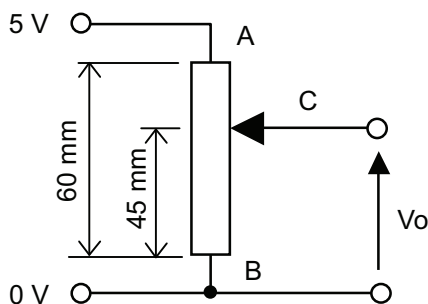

Fig. 2(a)

- (b) Fig. 2(b) shows part of a production line where components are heated by an oven as they move on a conveyor belt. The PIC circuit also shown in Fig. 2(b) is to be used to maintain the temperature in the oven, which utilises a high voltage heater, the required temperature being set by the variable resistor R_v .

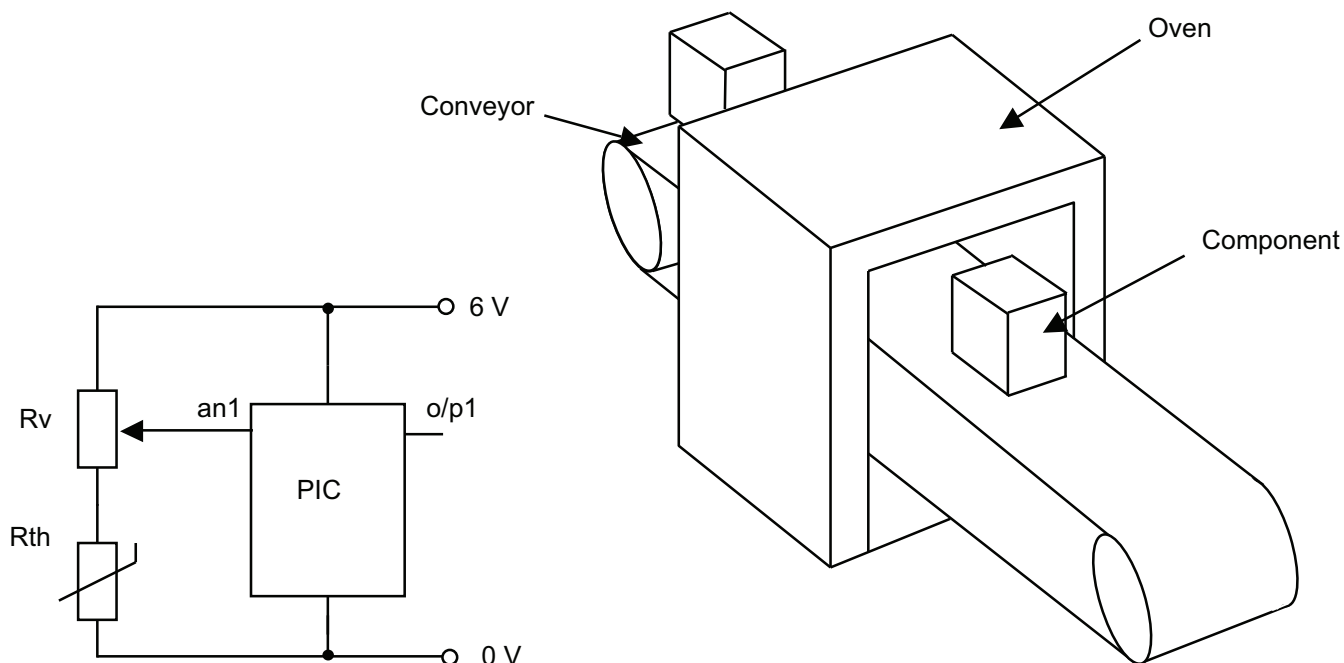

Fig. 2(b)

- (i) With reference to a PIC, explain the terms digital output and analogue input. [5]

The voltage range of the analogue port (an1) in **Fig. 2(b)** is from 0V to 6V with corresponding digital values ranging from 0 to 255. When the voltage at an1 is greater than 1.2 volts, the heater should be switched on. When the voltage at an1 is less than 0.8 volts the heater should be switched off.

(ii) Determine the digital values at an1 which correspond to 0.8 volts and 1.2 volts. [4]

(iii) Using the digital values from (b)(ii), write a flow chart program which will continuously check the input an1 and control the heater which is connected to output o/p1. [8]

(c) The conveyor system shown in **Fig. 2(b)** is to be driven by a 12V stepper motor and must move a fixed distance before stopping for the component to be heated in the oven. A disc with a hole is attached to the conveyor shaft as shown in **Fig. 2(c)**. This disc, in conjunction with a phototransistor, is to be used to determine the distance moved by the conveyor.

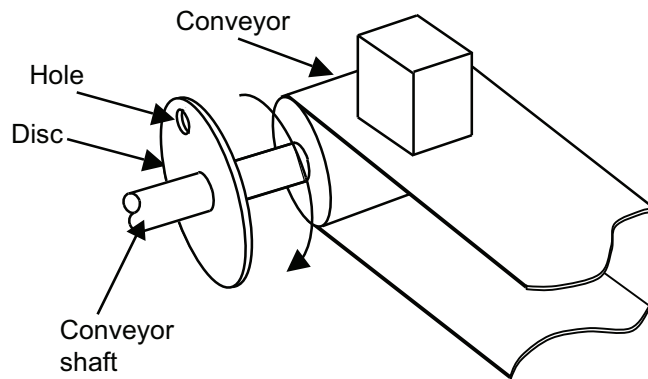

Fig. 2(c)

(i) Explain, with the aid of a sketch, the principle of operation of a phototransistor. [4]

(ii) The conveyor shown in **Fig. 2(c)** is required to move a distance of 60mm at a uniform speed in a period of five seconds where one pulse to the stepper motor driver causes the conveyor to move by 0.2mm. An astable timer is used to provide the input pulses to the stepper motor driver. Determine the required frequency of the astable timer. [3]

(iii) When the conveyor in **Fig. 2(c)** moves by 80cm, the disc will rotate four times. A PIC is to be used to count the number of rotations and stop the stepper motor after the fourth rotation for 15 seconds for the component to be heated. Design a circuit that will drive and control the stepper motor. Your answer should include an appropriate flowchart program. Assume the phototransistor arrangement at the disc provides a 5 volt pulse each time the disc rotates. [10]

BLANK PAGE

Section B

Mechanical and Pneumatic Control Systems

Answer **both** questions in this section.

- 3 (a) **Fig. 3(a)** shows a linkage which forms part of a prototype manual compactor for recycled waste. A force F is applied as shown which enables the compactor plate to press on the waste.

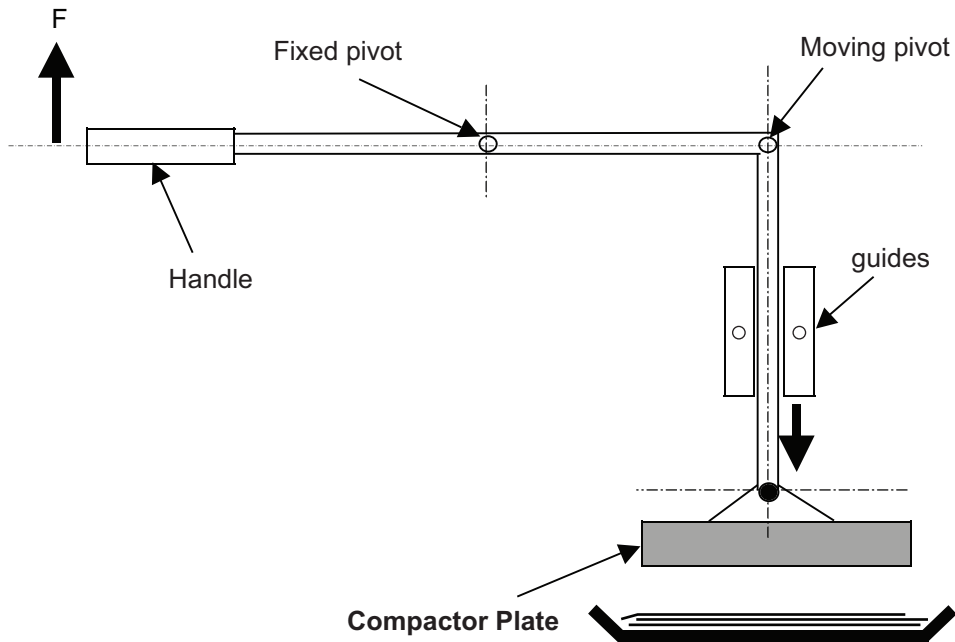

Fig. 3(a)

- (i) Explain **one** way in which the mechanical advantage of the compactor could be increased and justify your answer. [1]
- (ii) The compacted waste is stored in heavy bags for future transportation to a recycling plant. Design and draw a pulley block lifting system with a mechanical advantage of 6 to assist with the lifting of heavy bags. [3]
- (iii) Draw, describe and justify the use of a mechanism which could be used to prevent the pulley based lifting system from slipping backwards. [5]

Quality of written communication [4]

(b) Fig. 3(b) shows part of a prototype industrial waste compactor. The waste falls down from the hopper and is crushed between the compacting wheels.

(i) Calculate the overall velocity ratio between **A** and **N**. [6]

(ii) Using an annotated sketch, draw a sliding coupling arrangement at **Z** which would enable the motor to be detached easily for maintenance. [5]

(iii) Calculate the speed of the compacting wheel if **E** rotates at 800 rev/min. [6]

(iv) During testing, waste occasionally jams in the hopper and it needs to be manually shaken to release it. On the blank pro forma provided (answer number **3(b)(iv)**), design and draw a mechanical system to shake the hopper from side to side, 60 times each minute. This should have a total movement from side to side of 100 mm. Then design and draw a different mechanical system to move the hopper up and down 40 times each minute. Each time the hopper moves upwards, it should reach a height of 20 mm. [10]

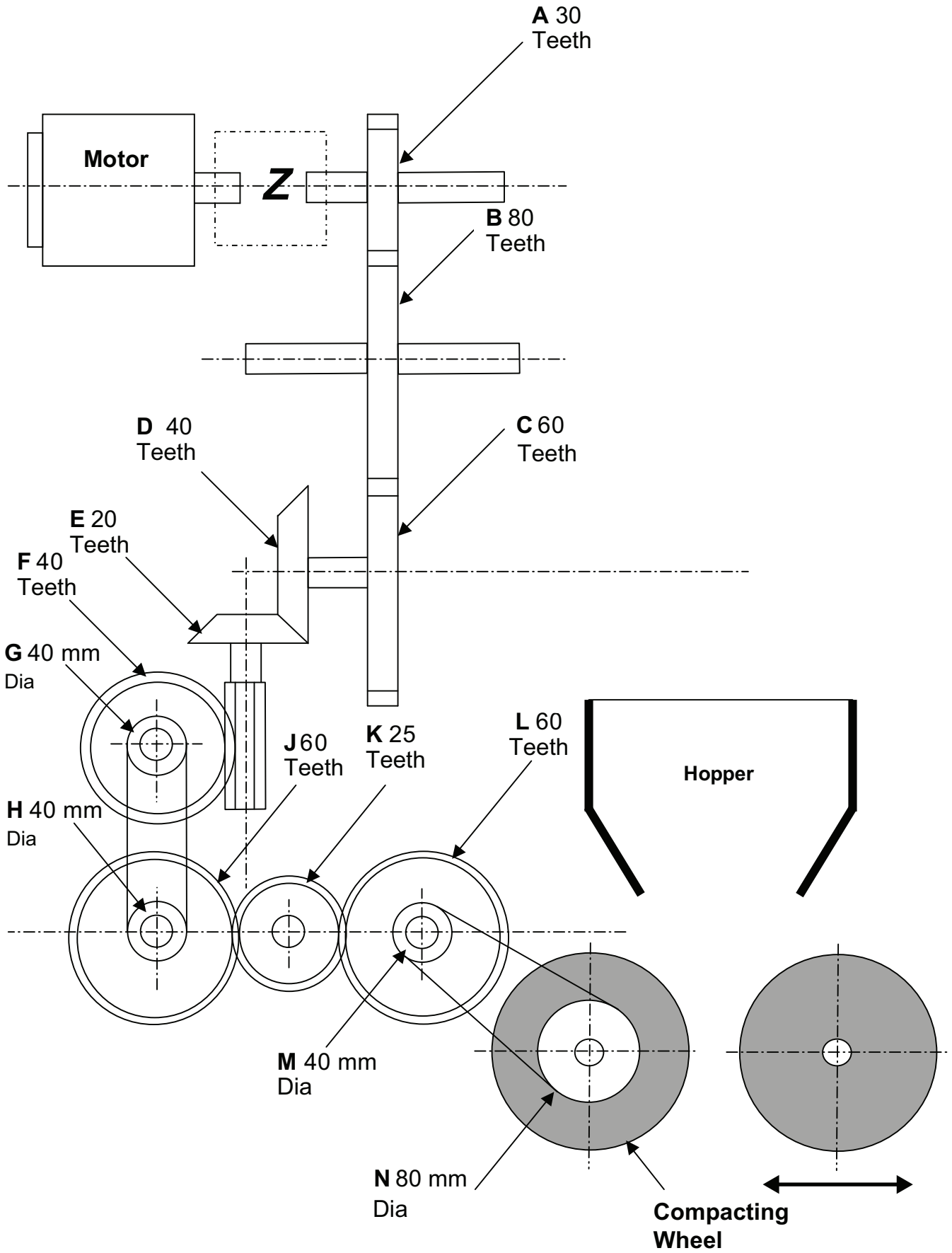

Fig. 3(b)

4 (a) (i) Explain what is meant by the term interlocking when applied to pneumatic systems. [2]

(ii) Fig. 4(a) shows part of a production line which moves small metal blocks from base 1 to base 2.

The following sequence begins when the start switch is activated:

- Cylinder A outstrokes, pushing cylinder B over base 1.
- Cylinder B outstrokes and the electromagnet secures the metal block.
- Cylinder B instrokes.
- Cylinder A instrokes to move cylinder B over the hopper.
- Cylinder C outstrokes to secure block Y.
- Cylinder D outstrokes to move block X to base 2.
- Cylinder D instrokes.
- Cylinder C instrokes.

On the pro forma provided (answer number **4(a)(ii)**), draw a suitable interlocking/cascade sequential pneumatic circuit to achieve the desired sequence. [16]

(iii) Cylinder A has a stroke length of 110 mm and produces a force during the outstroke of 600 N. Assuming an efficiency of 95%, calculate the total work done on the outstroke. [4]

(b) On the blank pro forma provided (answer number **4(b)**), design and draw a pneumatic system which will prevent the sequence in **4(a)(ii)** from starting if either of the following conditions occurs:

- Base 1 does not have a block to be lifted.
- The hopper is full and cannot accommodate a further block. [8]

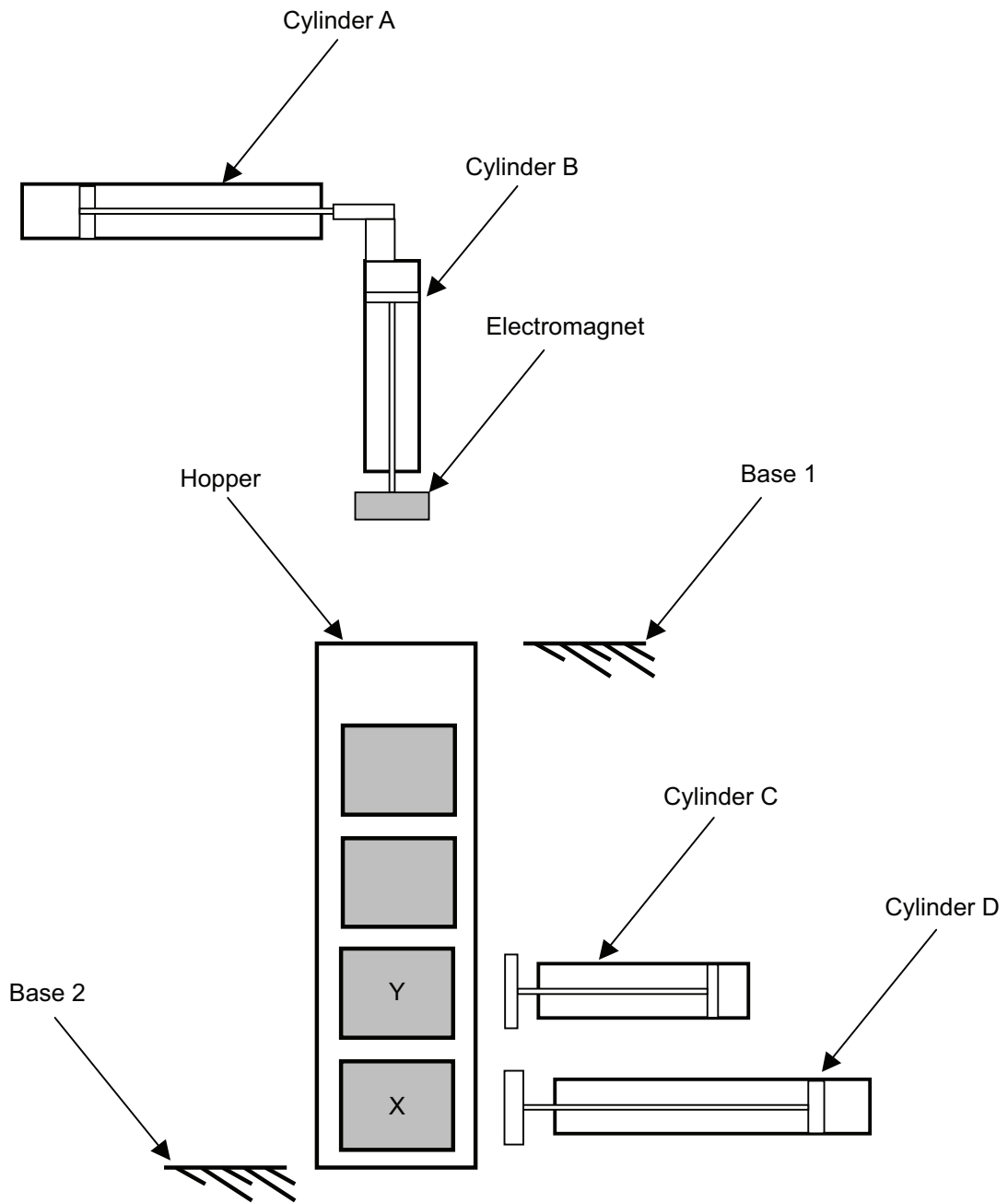

Fig. 4(a)

(c) Fig. 4(b) shows an incomplete pneumatic circuit at another stage in the production line, incorporating a double acting cylinder controlled by five port valve X. On the pro forma provided (answer number 4(c)), complete the circuit to enable the double acting cylinder to instroke with or without speed control when required. [10]

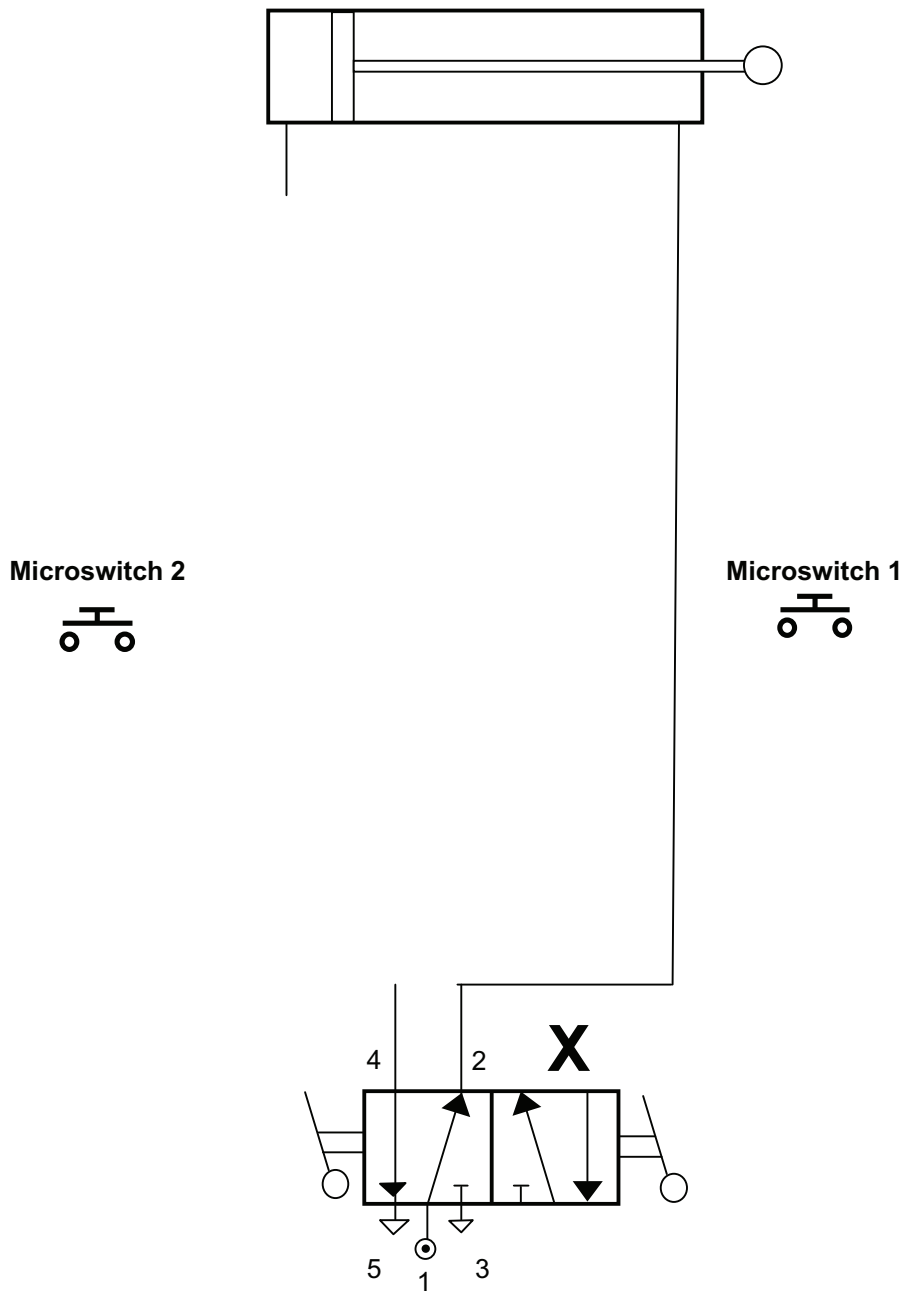

Fig. 4(b)

THIS IS THE END OF THE QUESTION PAPER

Permission to reproduce all copyright material has been applied for.
In some cases, efforts to contact copyright holders may have been unsuccessful and CCEA
will be happy to rectify any omissions of acknowledgement in future if notified.

Question No. 1(c)

ADVANCED LEVEL TECHNOLOGY AND DESIGN
Assessment Unit A2 1
January 2010

Centre Number

71

Candidate Number

**Pro forma answer page
(answer number 1(c))**

Question No. 3(b)(iv)

ADVANCED LEVEL TECHNOLOGY AND DESIGN
Assessment Unit A2 1
January 2010

Centre Number

71

Candidate Number

Pro forma answer page
(answer number 3(b)(iv))

Centre Number
 71

Candidate Number

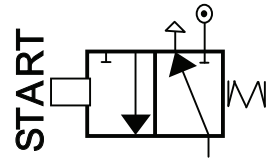
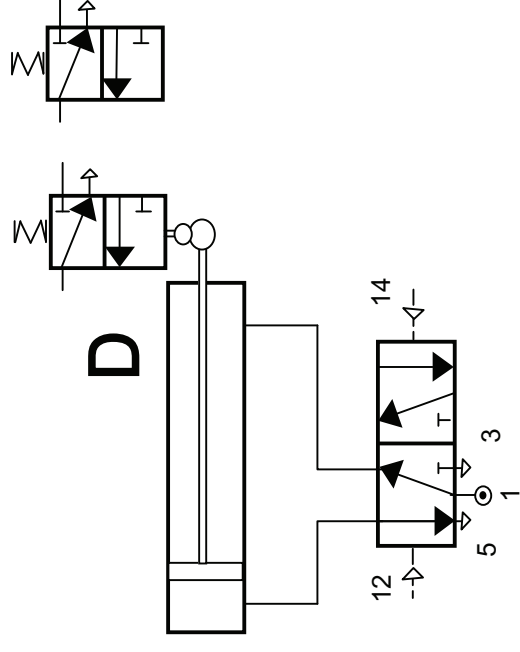
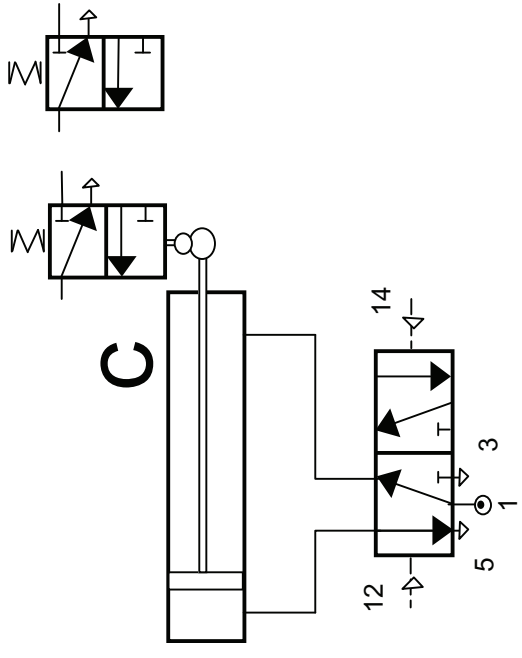
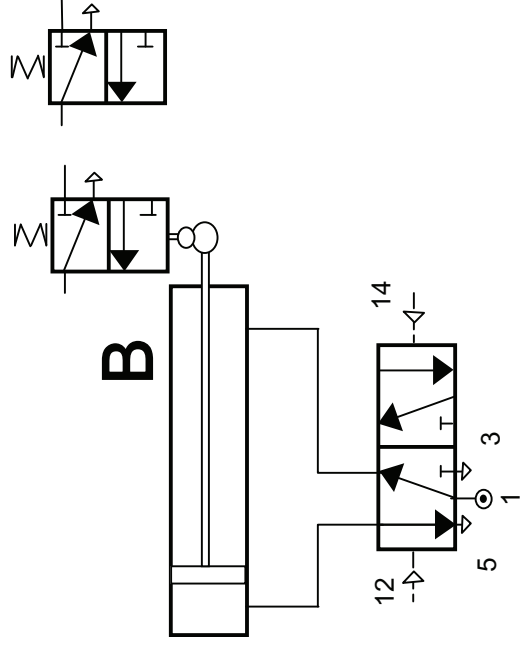
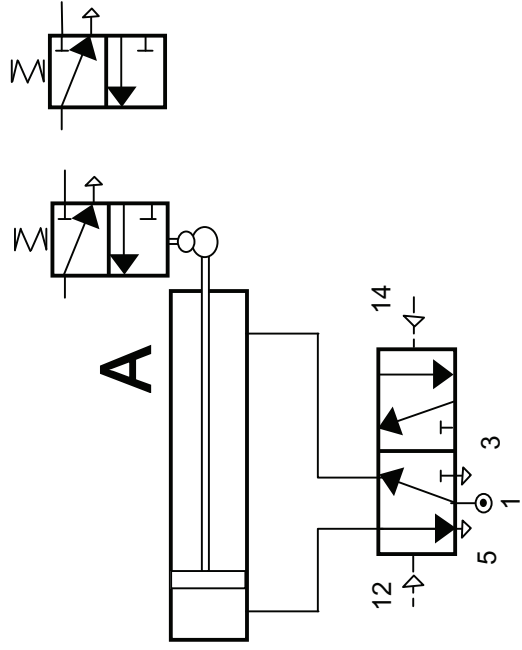

Pro forma answer page
 (answer number 4(a)(ii))

Question No. 4(b)

ADVANCED LEVEL TECHNOLOGY AND DESIGN
Assessment Unit A2 1
January 2010

Centre Number

71

Candidate Number

Pro forma answer page
(answer number 4(b))

71

--

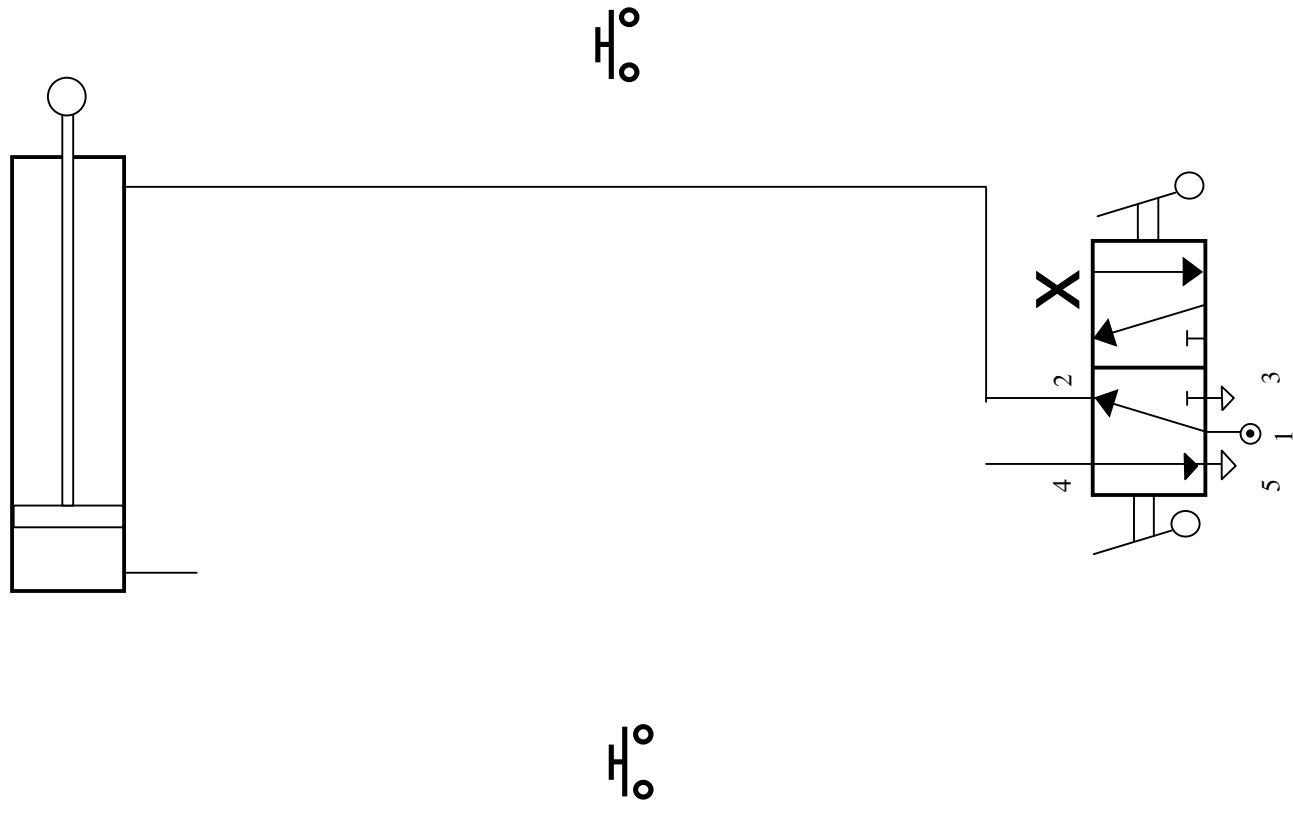

**Pro forma answer page
(answer number 4(c))**