



**ADVANCED GCE**  
**PHYSICS B (ADVANCING PHYSICS)**  
Advances in Physics

**2865/01**

**Tuesday 16 June 2009**

**ADVANCE NOTICE ARTICLE**

**May be opened and given to candidates upon receipt.**



**INSTRUCTIONS TO CANDIDATES**

- Take the article away and read it through carefully. Spend some time looking up any technical terms or phrases you do not understand. You are **not** required to research further the particular topic described in the article.
- For the examination on 16 June 2009 you will be given a fresh copy of this article, together with a question paper. You will not be able to take your original copy into the examination with you.
- The values of standard physical constants will be given in the *Advancing Physics* Data, Formulae and Relationships Booklet. Any additional data required are given in the appropriate question.

**INFORMATION FOR CANDIDATES**

- Questions in Section A of Paper 2865/01, Advances in Physics, will refer to this *Advance Notice* article, and may give additional data related to it.
- Section A will be worth about 60 marks.
- Section B will consist of two questions. These will **not** be based on the *Advance Notice* article. Section B will be worth about 30 marks.
- There will be 4 marks for quality of written communication (QWC) assessed over the whole paper.
- This document consists of **8** pages. Any blank pages are indicated.

## X-rays – Seeing The Invisible

### The assassination of President Garfield

On July 2nd, 1881, the newly-elected US President James Garfield was shot at by an assassin (Fig.1), and one of the bullets remained lodged in his abdomen.



**Fig. 1**

5 Over the next few weeks doctors tried a number of means of locating the buried bullet. They tried to find the bullet by pushing metal rods, and even unsterile fingers, into the bullet's entry wound, and in doing so undoubtedly caused most of the injuries that led to the President's eventual death 11 weeks later.

10 One ingenious attempt to locate the bullet was tried by Alexander Graham Bell, the inventor of the telephone. He set up a circuit which produced short electrical pulses in a primary coil. A secondary coil was connected to a telephone earpiece, where a buzz could be heard. The loudness of the buzz increased when there was metal nearby.

15 Bell tested his apparatus by detecting bullets held in his mouth or under his armpit, and also used his detector to find bullets fired into slabs of meat. Unfortunately, the faint signal he was able to detect near the dying President proved to be due to the metal springs in the mattress on the President's bed. As metal bed-springs were then a new invention, it is understandable that Bell had not allowed for them. The true location of the bullet was not discovered until the post mortem examination. Ironically it proved to be in a position that would not have killed the President, if only the doctors had left it well alone.

## 20 Röntgen's discovery of X-rays

Bell was unsuccessful at his attempt to see inside the human body without cutting into it, but that aim was achieved in 1895, when Wilhelm Röntgen discovered X-rays. While observing the patterns of light emitted in highly evacuated tubes by the effect of high voltages, he noticed an effect on nearby fluorescent paper shielded from the tube by black card. He deduced correctly that an invisible radiation created in the tube was producing the fluorescence. He showed that these rays could affect photographic plates encased within black paper, and could also penetrate soft tissues of the body, as in his celebrated X-ray photograph of his wife's hand (Fig. 2).



Fig. 2

Some of the medical applications of Röntgen's discovery were quickly appreciated, as X-rays were used to locate splinters of glass or metal embedded in the bodies of patients. In the First World War, Marie Curie pioneered the use of X-rays in the French army to locate bullets, saving many lives in the process. Even soft tissues absorb some X-rays, as Fig. 2 shows, so X-rays were soon used to diagnose abnormalities within the soft tissues of the body, such as cancers, or the scar tissue produced by tuberculosis. By introducing into the body materials which strongly absorb X-rays, such as compounds of barium or iodine, it is possible to obtain X-ray pictures of the digestive tract, or of the circulatory system, for example.

### The nature of X-rays

But what are these X-rays? After their discovery in 1895, two other discoveries followed rapidly: of radioactivity, by Henri Becquerel in 1896, and of the electron, by J J Thomson, in 1897. These were all mysterious invisible radiations, and it was some time before the nature of all three was clarified.

It was suspected that X-rays were electromagnetic radiation of short wavelength, and this was eventually demonstrated elegantly by researchers following a suggestion from Max von Laue. In the early years of the 20th Century, there was considerable debate between Ludwig Boltzmann and his opponents, principally Ernst Mach, as to whether it was possible to prove that atoms existed – the sceptical Mach famously asked, about atoms, 'Have you seen one?'

Von Laue realised that, if crystals did consist of regular arrays of atoms, then they should act like diffraction gratings when illuminated with radiation of wavelength similar to the spacing between the rows of atoms. A diffraction grating, consisting of a regular array of slits, produces a pattern of spots in a straight line when a narrow beam of light of a single wavelength passes through it. Two such gratings, placed at right angles to each other and superimposed, form a square lattice, and the diffraction pattern produced by this will be a square grid of spots (Fig. 3).

50

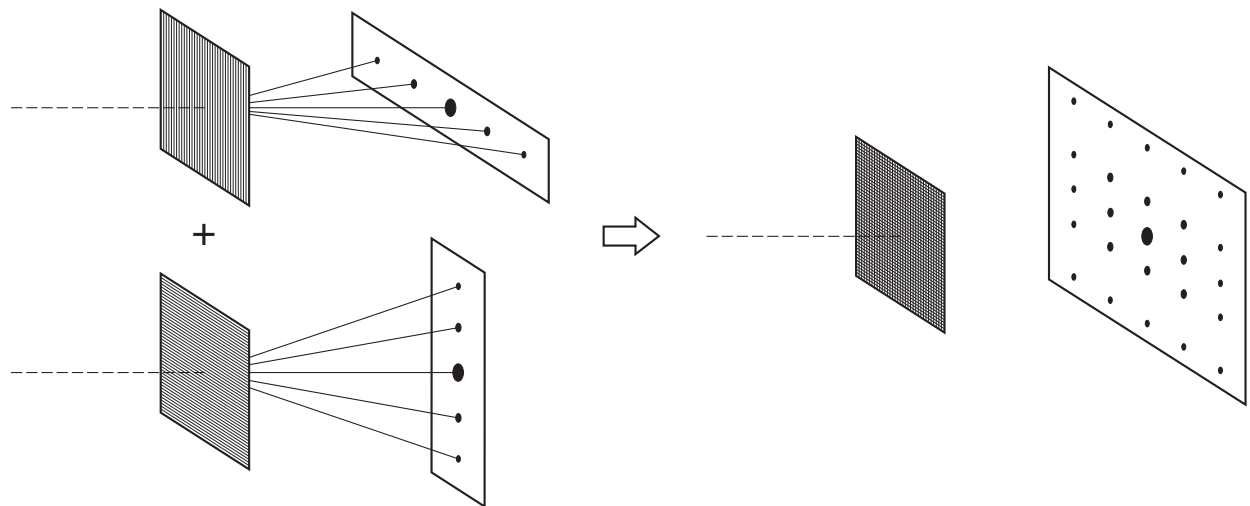

Fig. 3

Although crystals are more complex, a regular lattice of atoms should produce a diffraction pattern of spots when waves of appropriate wavelength are incident on them. This was confirmed in 1912 by Friedrich and Knipping, who passed a narrow beam of X-rays through a crystal and obtained a regular pattern of dots on a photographic plate placed on the far side of the crystal (Fig. 4).

55

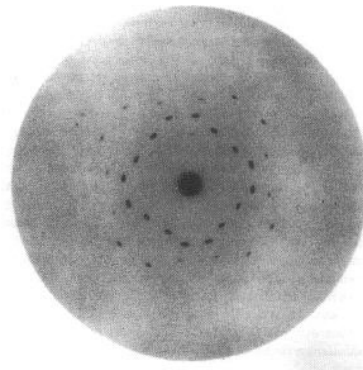

Fig. 4

This was not only the answer to Mach's question about whether atoms could be seen, but also the birth of X-ray crystallography, which enabled scientists to deduce the structure of crystalline materials. This led to a number of Nobel prizes, including those awarded to Dorothy Hodgkin for finding the structure of vitamin B-12, and to Watson and Crick for the structure of DNA; the experimental X-ray work used by Crick and Watson was done by Rosalind Franklin, but her tragically early death meant that she was not eligible for the Nobel Prize herself.

60

## The production of X-rays

65 Röntgen produced X-rays by firing high-energy electrons at the anode of the discharge tubes he was experimenting with. The decelerating electrons lose energy, which is emitted as X-rays of a range of wavelengths down to a minimum value, dependent on the electron energies used. When the electrons have enough energy to dislodge inner electrons in the atoms they hit, large intensities of certain well-defined wavelengths of X-rays are produced. Research into these 'characteristic X-rays' produced from a wide range of anode materials, by Henry Moseley in 1914, led to the establishment of the modern form of the Periodic Table. In modern X-ray tubes, the electrons are emitted from heated cathodes and collide into metals of high mass number, such as tungsten, embedded in the anode. The conversion to X-rays is only about 1% efficient, so the anode becomes very hot, even though the current is only a few milliamps. It has to be cooled to remove the heat produced when the electrons collide with the atoms of the target (Fig. 5).

70

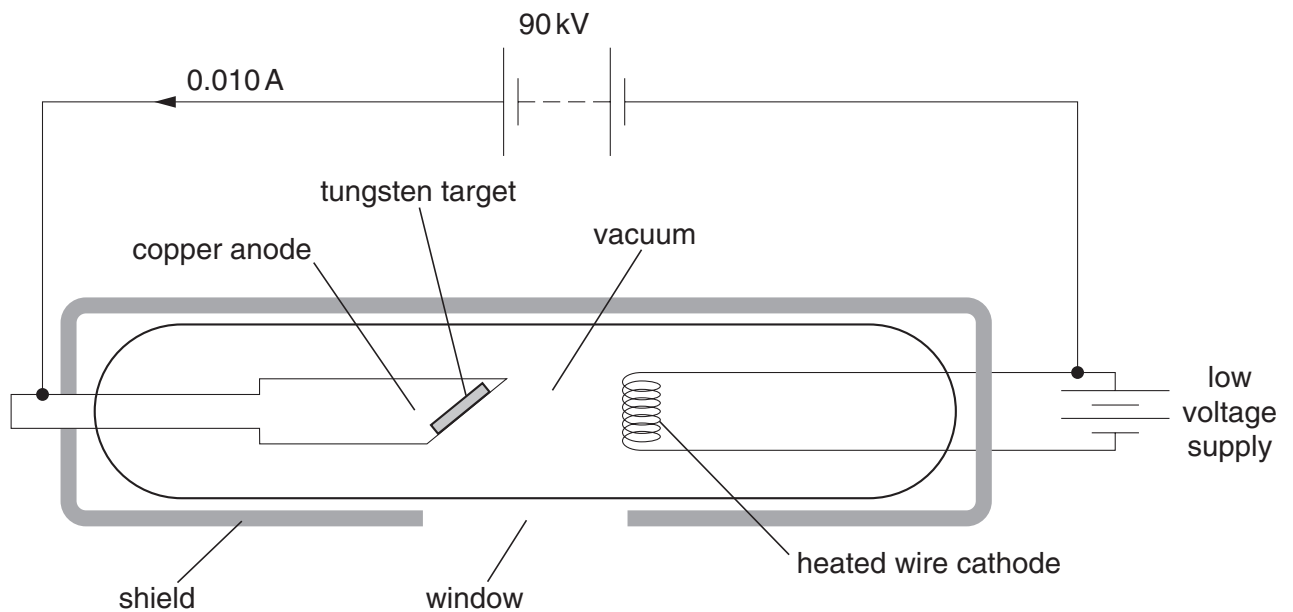

**Fig. 5 – a modern X-ray tube**

## X-rays and risk

- 75 In the early decades of the 20th Century, workers with X-rays had substantial damage to their bodies, often leading to premature death. The American inventor Thomas Edison abandoned his researches into X-rays when one of his technicians, who used to test his X-ray tubes with his hands, developed cancers which killed him. It took some time for the dangers to be generally recognised, and as late as the 1960s it was still common for children to have their feet X-rayed to check whether shoes fitted correctly. Fig. 6 shows such a machine, where the child would put his or her feet into the slot at the bottom, immediately above the X-ray tube, which was shielded by about 1 mm of aluminium. Toward the top of the machine, the X-rays struck a fluorescent plate, which absorbed some of the X-ray photons and emitted visible ones. The child, the parent and the shoe fitter could see the image through the three viewing tubes at the top.
- 80
- 85 Understandably, these machines are no longer used in shoe shops.

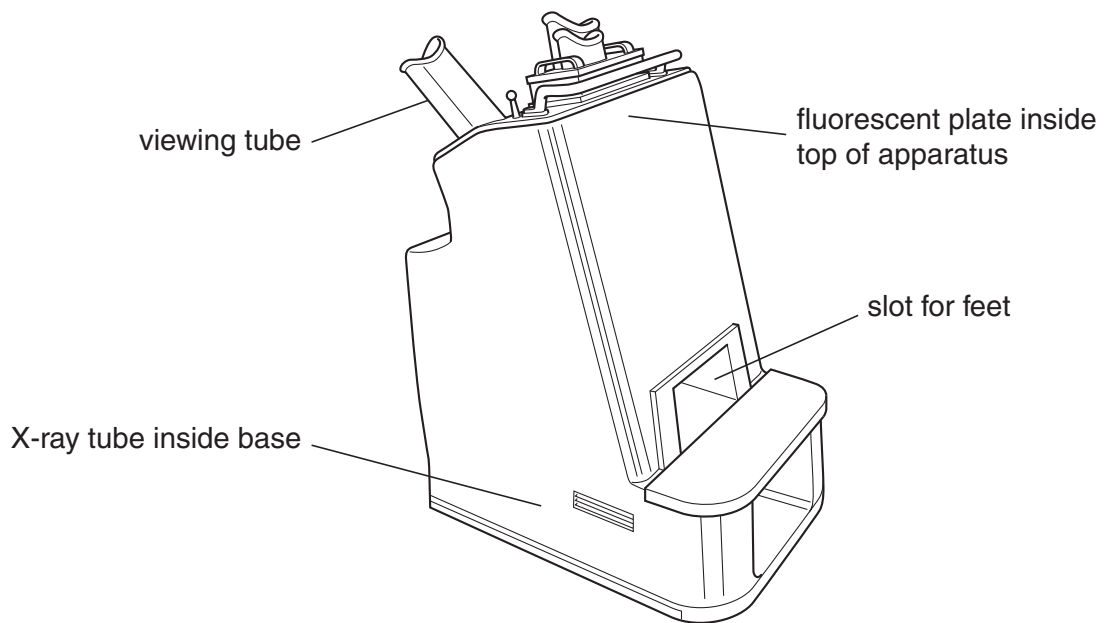

**Fig. 6**

## Modern medical X-rays

- The resolution of photographic plates is better than current digital systems. However, for speed, and to make computer storage and manipulation possible, digital methods are increasingly used. Detection may involve the absorption of the X-rays by a scintillating material, which emits visible photons which can then be recorded digitally, as with any visible picture. Alternatively, the detector may be a CCD semiconductor device like those found in digital cameras, with the addition of a scintillating material. Because these materials convert a higher fraction of the X-ray photons to visible photons than the fraction absorbed by standard photographic film, they allow images to be obtained with smaller doses to the patient.
- 90
- 95 Trained radiographers can see a lot of detail in a standard X-ray photograph, but it has limitations. The image is a shadow picture of the absorption of X-rays by the internal organs of the body, so you cannot tell if one organ lies under or over another. Whether the patient is X-rayed facing towards or away from the detector, essentially the same information is obtained. Turning the patient through 90°, however, gives a different view, and this is frequently done to locate a position
- 100 accurately within the body.

In the 1970s, computerised tomography (CT) scanners were developed to extend this principle of obtaining information from many 'views' through the body. 'Tomography' means 'drawing slices', and the images produced do appear as slices through the body.

A CT scanner (Fig. 7) has the X-ray tube and the detector opposite to each other in a large doughnut shape, with the patient in the middle (Fig. 7).

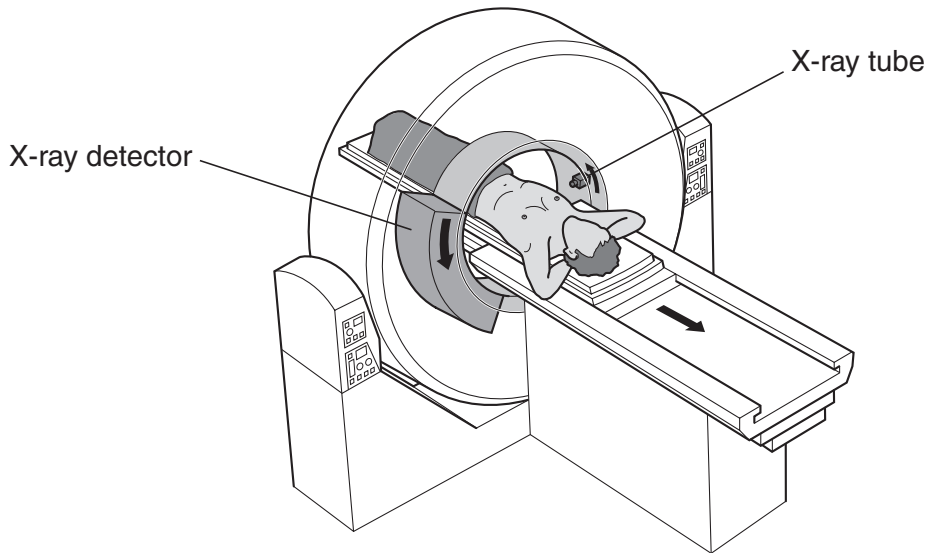

**Fig. 7**

The X-ray tube and detector move around the patient, recording the different absorptions of X-rays from every angle. This information is then processed by computer to give a map of X-ray intensities across a 'slice' of the patient, and is able to discriminate quite small differences between the tissues.

110 During the scan, the patient moves through the scanner in the direction shown by the arrow on Fig. 7. Although the patient is exposed to X-rays for a longer time, much more information is obtained than in an ordinary flat X-ray. The process allows the computer to collect more information about the region of the patient of interest, and this can then be processed to present 'slices' through the body (Fig. 8).

115 Magnetic Resonance Imaging (MRI) scans are similar in result to CT scans. The patient lies inside a large solenoid producing a strong magnetic field, and a varying radio signal stimulates resonant signals from nuclei of odd nucleon number. In the body, these nuclei are effectively those of hydrogen. The resulting MRI scan shows differences in the concentration of hydrogen nuclei in different tissues (Fig. 9). Both CT and MRI images can be enhanced digitally to show  
120 features of interest more clearly.



CT scan of the brain

**Fig. 8**

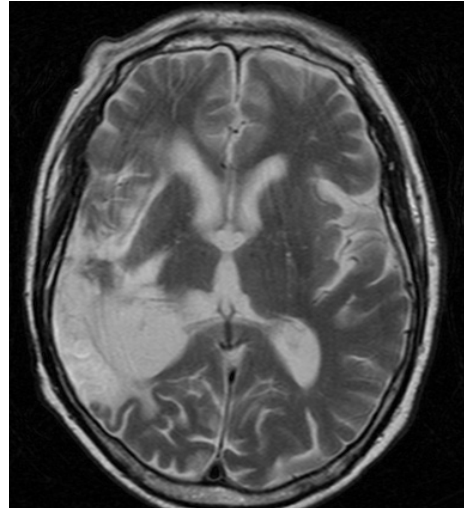

MRI scan of the brain

**Fig. 9**

With the development of MRI, it seems as if remote sensing within the human body has come full circle. It started with magnetism in Bell's attempt to locate the bullet in President Garfield. Now Magnetic Resonance Imaging competes with CT scans, to give similar results, as can be seen from Figs. 8 and 9. However, both methods have advantages in different circumstances:  
125 CT scans are better where bone is being investigated, but MRI gives more detail in soft tissues. An MRI scan does not use ionising radiation, so there are no medical risks to the patients, apart from those with heart pacemakers or metal implants. However, the MRI scanner is noisy, and the patient has to lie still within a long solenoid for up to 45 minutes, which many people find extremely uncomfortable. MRI scanners are also much more expensive than CT scanners, so  
130 hospitals need to consider carefully how their resources are best spent.

**END OF ARTICLE**

**Copyright Information**

OCR is committed to seeking permission to reproduce all third-party content that it uses in its assessment materials. OCR has attempted to identify and contact all copyright holders whose work is used in this paper. To avoid the issue of disclosure of answer-related information to candidates, all copyright acknowledgements are reproduced in the OCR Copyright Acknowledgements Booklet. This is produced for each series of examinations, is given to all schools that receive assessment material and is freely available to download from our public website ([www.ocr.org.uk](http://www.ocr.org.uk)) after the live examination series.

If OCR has unwittingly failed to correctly acknowledge or clear any third-party content in this assessment material, OCR will be happy to correct its mistake at the earliest possible opportunity.

For queries or further information please contact the Copyright Team, First Floor, 9 Hills Road, Cambridge CB2 1PB.

OCR is part of the Cambridge Assessment Group; Cambridge Assessment is the brand name of University of Cambridge Local Examinations Syndicate (UCLES), which is itself a department of the University of Cambridge.