



**ADVANCED SUBSIDIARY GCE
PHYSICS B (ADVANCING PHYSICS)**
Physics in Action

G491

Candidates answer on the question paper

OCR Supplied Materials:

- Data, Formulae and Relationships Booklet

Other Materials Required:

- Electronic calculator
- Ruler (cm/mm)

**Tuesday 13 January 2009
Afternoon**

Duration: 1 hour

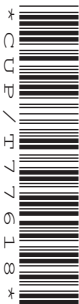

Candidate Forename		Candidate Surname	
--------------------	--	-------------------	--

Centre Number							Candidate Number				
---------------	--	--	--	--	--	--	------------------	--	--	--	--

INSTRUCTIONS TO CANDIDATES

- Write your name clearly in capital letters, your Centre Number and Candidate Number in the boxes above.
- Use black ink. Pencil may be used for graphs and diagrams only.
- Read each question carefully and make sure that you know what you have to do before starting your answer.
- Answer **all** the questions.
- Do **not** write in the bar codes.
- Write your answer to each question in the space provided, however additional paper may be used if necessary.

INFORMATION FOR CANDIDATES

- The number of marks is given in brackets [] at the end of each question or part question.
- The total number of marks for this paper is **60**.
- You are advised to spend about 20 minutes on Section A and 40 minutes on Section B.
- The values of standard physical constants are given in the Data, Formulae and Relationships Booklet. Any additional data required are given in the appropriate question.
- Where you see this icon you will be awarded marks for the quality of written communication in your answer. This means, for example, you should
 - ensure that text is legible and that spelling, punctuation and grammar are accurate so that meaning is clear;
 - organise information clearly and coherently, using specialist vocabulary when appropriate.
- This document consists of **20** pages. Any blank pages are indicated.

FOR EXAMINER'S USE		
Section	Max.	Mark
A	19	
B	41	
TOTAL	60	

Answer **all** the questions.

Section A

1 Here is a list of units.

$C s^{-1}$ $J C^{-1}$ $J s^{-1}$ $V A^{-1}$ $V A$

Choose the correct unit for

(a) electric current

(b) potential difference

[2]

2 The diagram below is an image of Saturn's moon Iapetus.

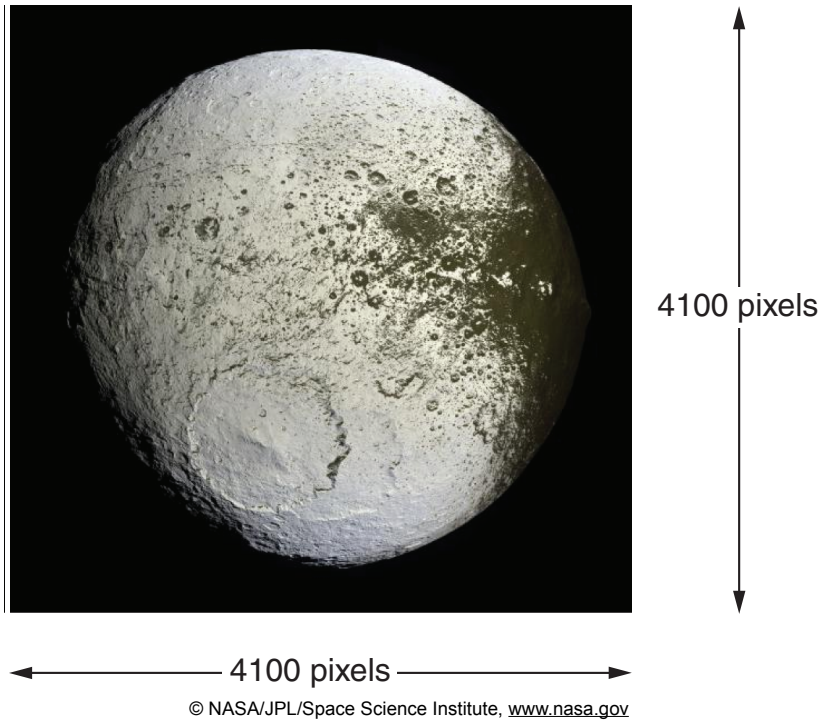

The resolution of the image is 400 m pixel^{-1} . The image above is $4100\text{ pixels} \times 4100\text{ pixels}$. Estimate the diameter of Iapetus in kilometres.

diameter = km [2]

3

3 The three sound signals on the left, all shown to the same scale, give the three frequency spectra on the right.

(a) Draw a straight line joining each waveform to its correct frequency spectrum.

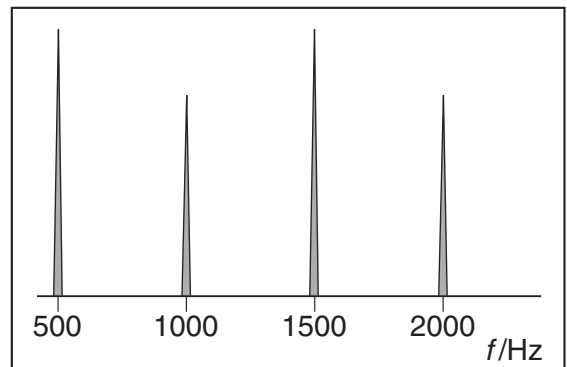
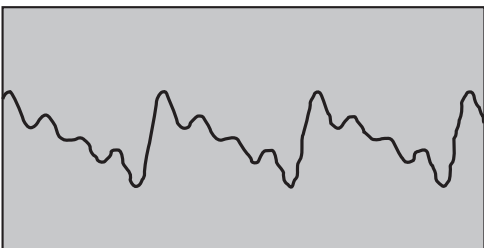
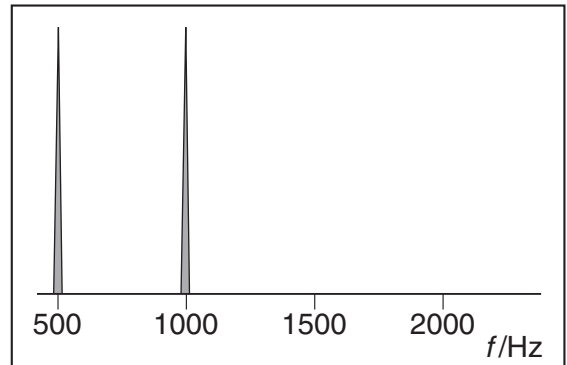
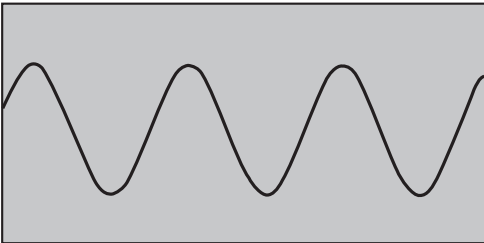
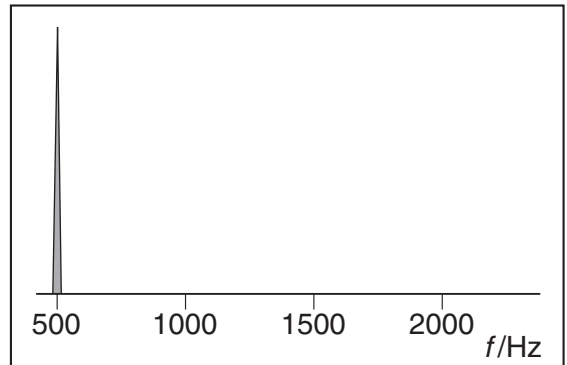
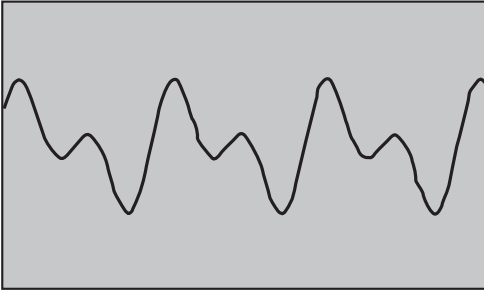

[1]

(b) When the three signals are played, they all sound at the same pitch. Explain why this is so.

[1]

4 A neon indicator lamp needs 90V in order to conduct. It then draws a current of 0.5 mA.

(a) Calculate the resistance of the lamp at this voltage and current.

resistance = Ω [2]

(b) Calculate the number of electrons moving through of the lamp each second.

electron charge $e = 1.6 \times 10^{-19} \text{ C}$

number = s^{-1} [2]

5 (a) A song is being recorded at a sampling frequency of 44 100 Hz with 16 bits per sample for each of the **two** stereo channels. Calculate the rate, in bytes per second, at which data is processed.

rate = bytes s^{-1} [1]

(b) The recording system has a random electrical 'noise' signal of amplitude $2 \mu\text{V}$. The total voltage variation in the circuit is 0.2V.

Explain why this means that there is no advantage to recording with more than 16 bits per sample.

[2]

- 6 A resistor has resistance $2.5\ \Omega$.

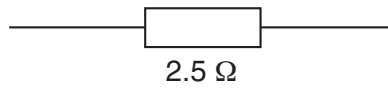

- (a) Calculate its conductance.

conductance = unit [2]

- (b) Calculate the conductance of three such $2.5\ \Omega$ resistors arranged in parallel.

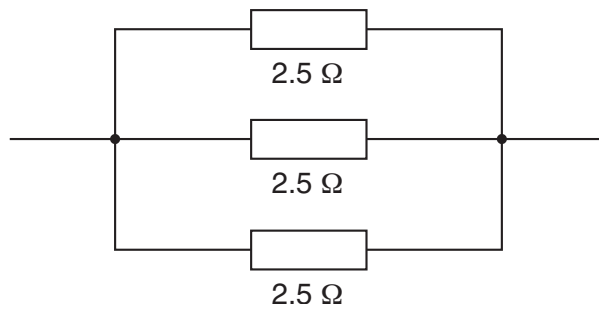

conductance = unit [1]

- 7 The material selection chart below shows the cost of different materials and the fraction of those materials that can be recycled.

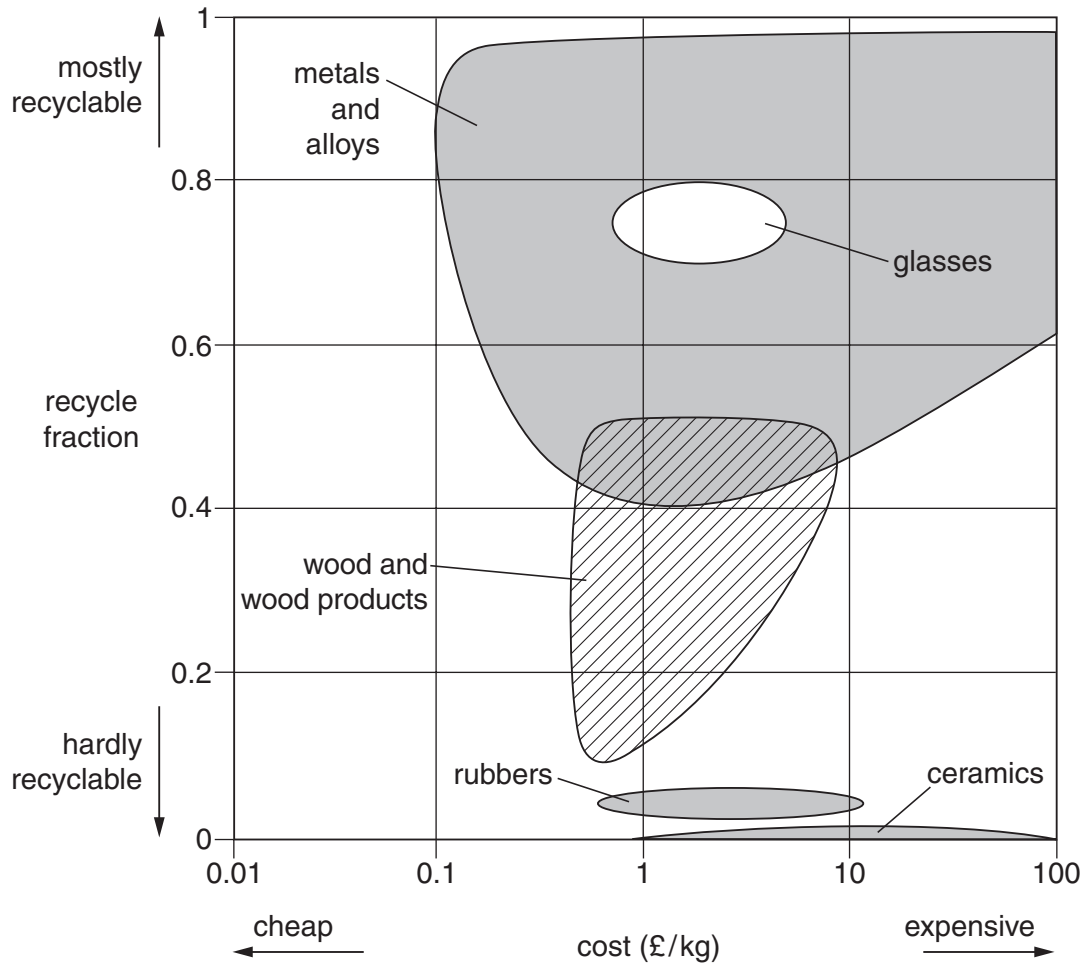

- (a) Explain how you can see that the horizontal (cost) axis of this chart is **logarithmic**.

[1]

- (b) Use the information in the chart to describe the differences in cost and recyclability between **glasses** and **metals and alloys**.

[1]

7

- (c) Suggest why metals are easy to recycle, while ceramics such as pottery are almost impossible to recycle.

[1]

[Section A Total: 19]

8
Section B

- 8 This question is about elastomers, polymers which can extend a great amount under stress and return to their original size.

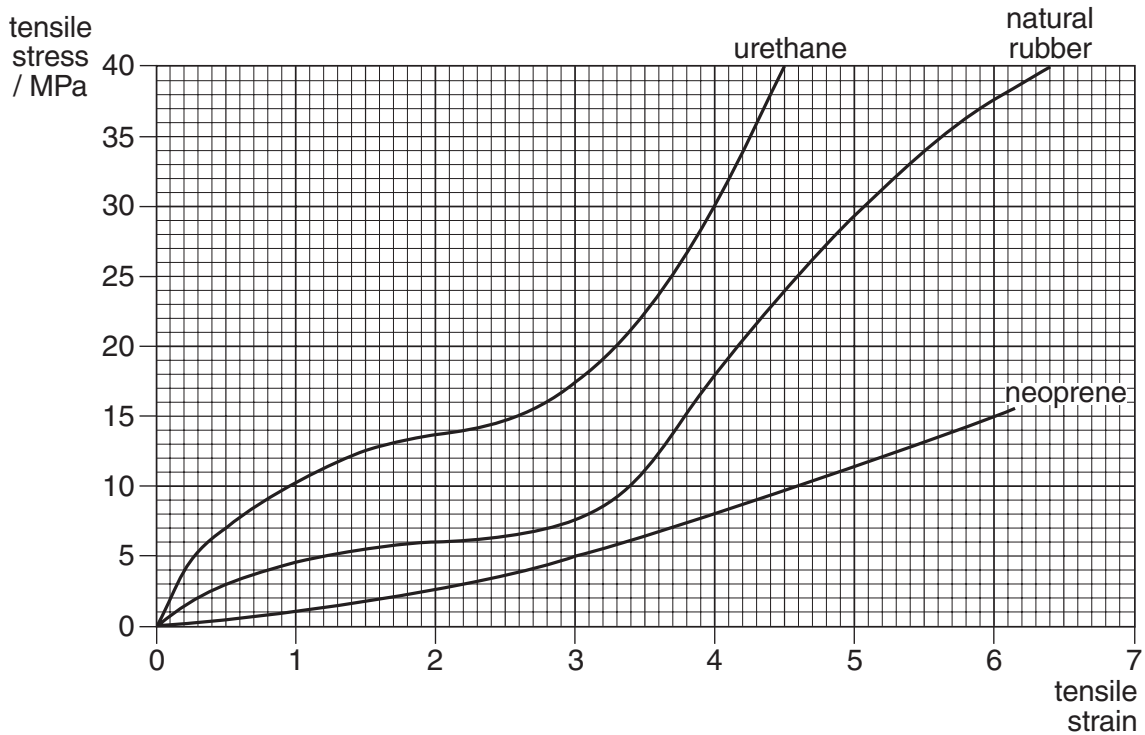

Fig. 8.1

- (a) Fig. 8.1 shows the stress-strain curves for three elastomers: urethane, natural rubber and neoprene.

Imagine you were to pull a strip of **natural rubber** until it was six times its original length, and then repeat this with a similar strip of **neoprene**. Use the graph to describe what you would feel when you stretched the natural rubber and neoprene.

[3]

- (b) (i) Use data from the graph to find a value of the Young modulus for **urethane** at a tensile strain of 4.0. Give your answer to an appropriate number of significant figures.

Young modulus $E = \dots\dots\dots$ Pa [3]

- (ii) Consider the Young modulus of **urethane** at a strain of 3.0. Explain whether it is larger or smaller than the value calculated in (b)(i).

[1]

- (c) A natural rubber cord, initially 20 cm long, has a 30 N load attached to it, and it stretches to a length of 1.0 m.

- (i) Calculate the strain in the rubber cord.

strain = $\dots\dots\dots$ [1]

- (ii) Use the graph of Fig. 8.1 to find the area of cross-section of this **natural rubber** cord while it is stretched by the 30 N load.

area of cross-section = $\dots\dots\dots$ m² [3]

[Total: 11]

- 9 This question is about an experiment to find the power and focal length of a lens.

In an experiment, students varied the distance u between a point source of light and a lens, and measured the corresponding distance v from the lens to a screen on which a real image was formed.

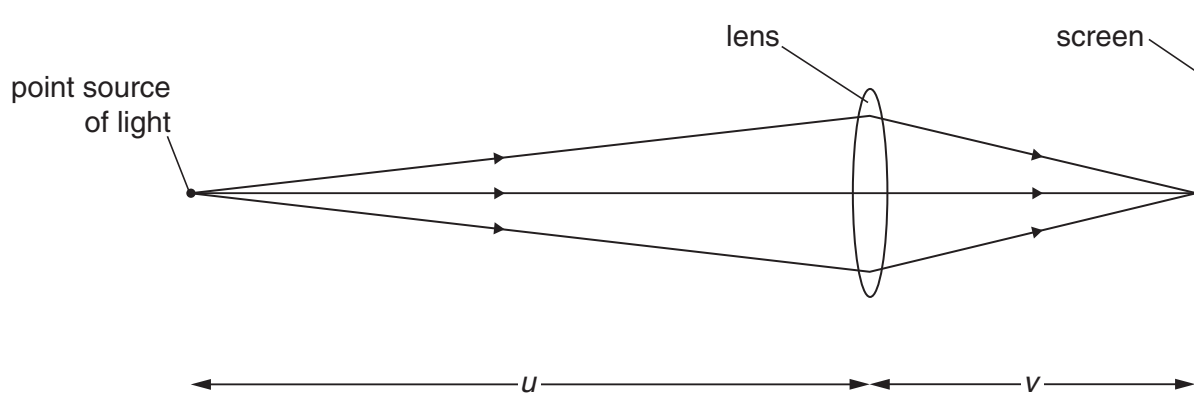

Fig. 9.1

For each object distance u , the students found there was a range of positions of the screen for which the image looked quite sharp, so they recorded the smallest and largest possible values of v for each value of u .

The data the students obtained are shown in Table 1.

u/m	v/m	
	smallest value	largest value
-0.220	0.890	1.090
-0.280	0.490	0.540
-0.330	0.390	0.420
-0.400	0.325	0.340
-0.485	0.285	0.290
-0.550	0.270	0.272

Table 1

- (a) (i) Suggest a reason why any uncertainty in the values for u can be neglected.

[1]

- (ii) Describe the variation of uncertainty in v shown by these data.

[1]

QUESTION 9 CONTINUES ON PAGE 12

(b) The students use the results of Table 1 to produce Table 2:

$\frac{1}{u}$ (u in m)	$\frac{1}{v}$ (v in m)	
	largest value	smallest value
-4.55	1.12	0.92
-3.57	2.04	1.85
-3.03	2.56	2.38
-2.50	3.08	2.94
-2.06	3.51	3.45
-1.82	3.70	3.68

Table 2

The equation that gives the power of the lens, P is

$$\frac{1}{v} = \frac{1}{u} + P.$$

A graph of $1/u$ (horizontally) against $1/v$ (vertically) should give a straight line of gradient 1 and intercept on the $1/v$ axis of P .

In the graph of Fig. 9.2, the data in Table 2 with the exception of the top and bottom rows have been plotted.

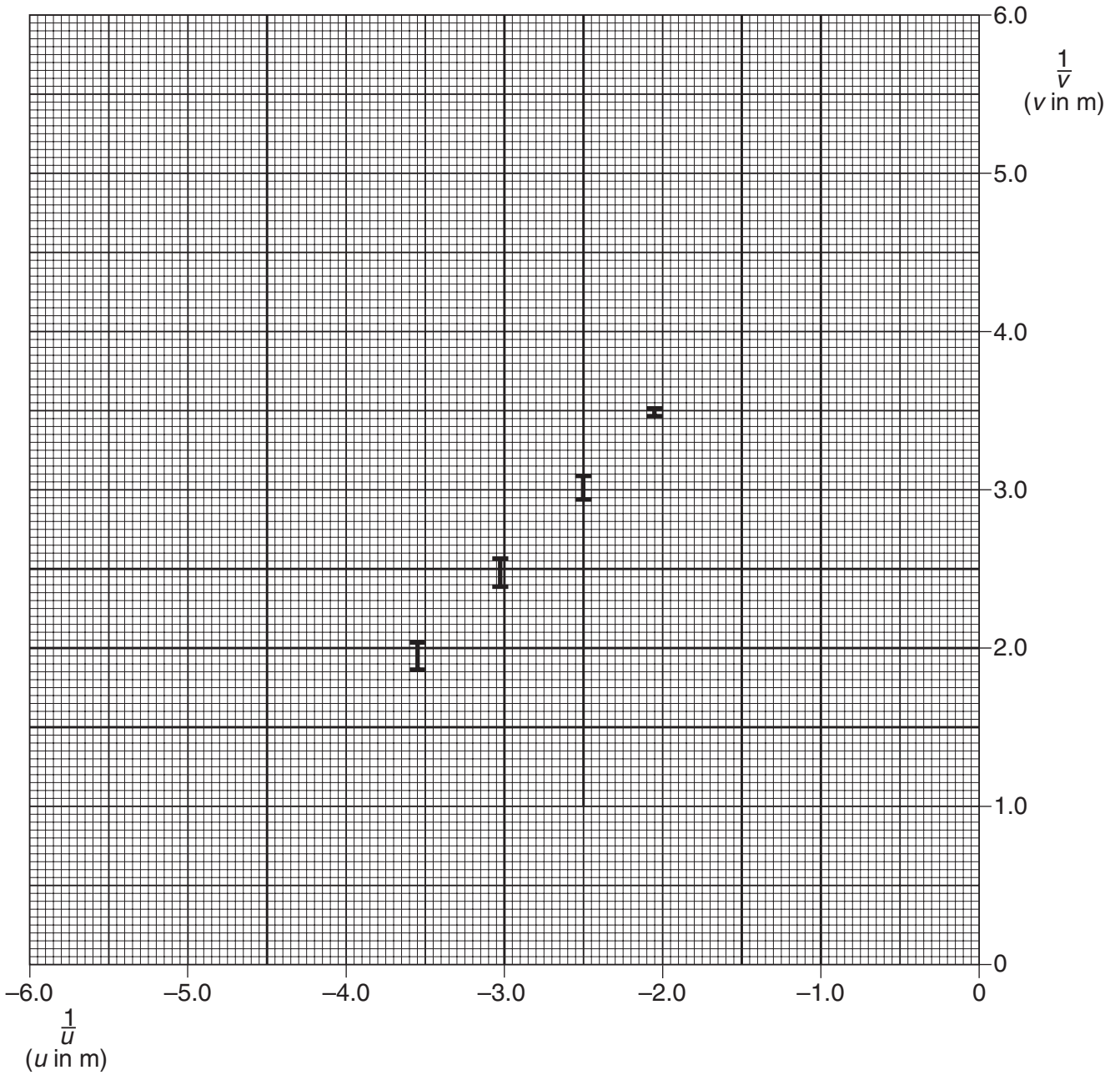

Fig. 9.2

(i) Plot the remaining data on the graph and add a best-fit straight line.

[3]

(ii) Use the graph to find the focal length of the lens.

focal length = m [2]

(c) In their experiment, the students found it difficult to get a sharp, clear image.

The experiment was repeated with a black paper ring covering the outer parts of the lens (Fig. 9.3).

They also used pure yellow light of wavelength 590 nm instead of white light.

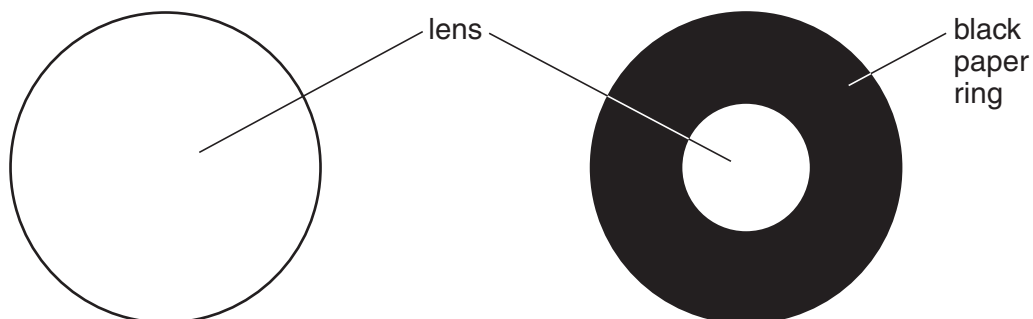

Fig. 9.3

The following results were obtained:

u/m	v/m	
	smallest value	largest value
-0.220	1.038	1.052
-0.280	0.510	0.520
-0.330	0.402	0.409
-0.400	0.330	0.335
-0.485	0.288	0.292
-0.550	0.270	0.272

Table 3

(i) Describe how the uncertainties in v have changed from the values given in Table 1.

[1]

- (ii) Describe clearly what these results suggest about the **lens**.

[2]

[Total: 10]

QUESTION 10 IS ON THE FOLLOWING PAGE

10 This question is about the microscopic structure of iron.

- (a) Measurements on a scanning tunnelling microscope image of iron atoms arranged on a copper surface show that the diameter of an iron atom is 2.6×10^{-10} m.

Fig. 10.1

- (i) Assuming that each iron atom is a sphere, show that its volume is about 9×10^{-30} m³.

for a sphere of radius R , the volume $V = \frac{4}{3} \pi R^3$

[2]

- (ii) Density is defined as

$$\text{density} = \frac{\text{mass}}{\text{volume}}$$

Use your answer to (i) to estimate an upper limit to the density of iron.

mass of iron atom = 9.3×10^{-26} kg.

density = kg m⁻³ [1]

- (iii) A rectangular block of iron measuring 0.040 m × 0.050 m × 0.080 m at room temperature has a mass of 1.26 kg.

Show that this is less dense than the value obtained in (ii).

[1]

- (b) In crystals of iron at room temperature, the atoms are arranged in the body-centred cubic pattern shown in Fig. 10.2.

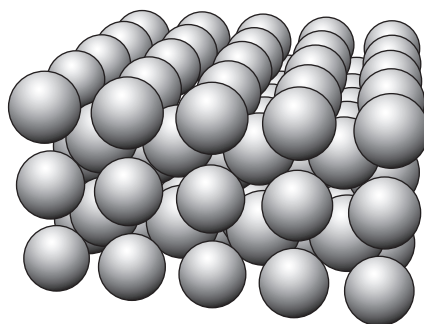

Fig. 10.2

Use this information to explain why the density calculated in (a) is bigger than the measured density of iron at room temperature.

[2]

- (c) When iron is heated above 920°C , it contracts because the atoms move into the face-centred cubic pattern shown in Fig. 10.3.

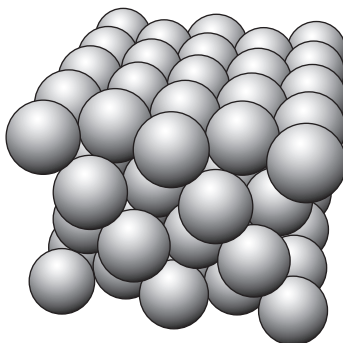

Fig. 10.3

Suggest and explain **one** change in the properties of iron when it is heated from just below 920°C to just above 920°C .



In your answer you should clearly link changes in the atomic structure to a change in the properties of iron.

[3]

[Total: 9]

Turn over

11 This question is about a type of thermistor.

A PTC (positive temperature coefficient) thermistor increases in resistance as its temperature increases.

The circuit in Fig. 11.1 has a 6V battery connected to a PTC thermistor in series with a $500\ \Omega$ resistor.

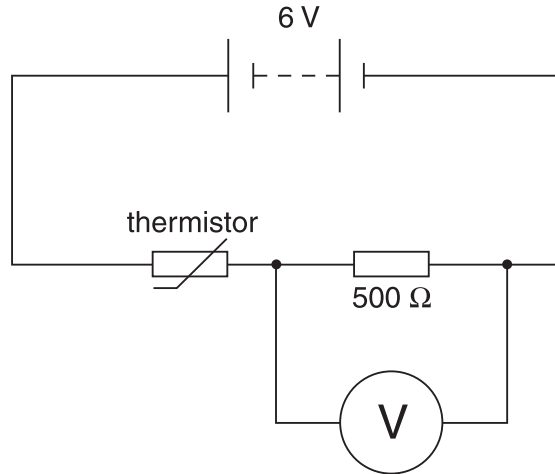

Fig. 11.1

(a) At a temperature of 20°C , the thermistor has a resistance of $260\ \Omega$.

(i) Show that the p.d. across the $500\ \Omega$ resistor is about 4V.

[2]

(ii) Calculate the current in the circuit.

current = A [1]

- (b) As the thermistor is heated to 90°C , its resistance increases to $10\,000\,\Omega$.

State and explain what would happen to the p.d. measured by the voltmeter in Fig. 11.1 as the temperature of the thermistor increases from 20°C to 90°C .

You do not need to do any calculations.

[2]

- (c) The variation of resistance R with temperature T for this PTC thermistor is shown in the graph of Fig. 11.2.

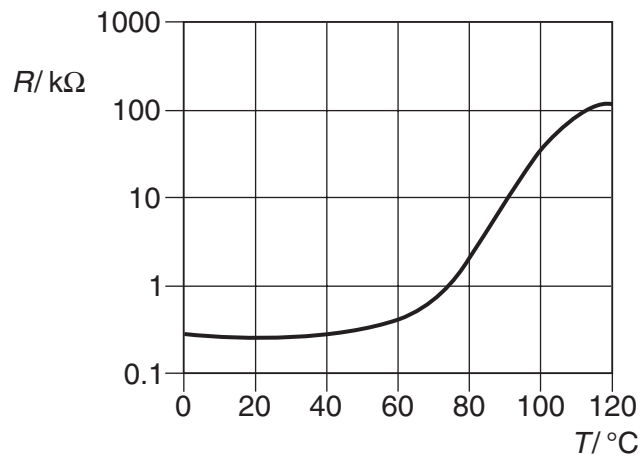

Fig. 11.2

The circuit of Fig. 11.1 can be used as a temperature sensor.

Use the graph of Fig. 11.2 to suggest why this sensor would not be very suitable for controlling the temperature of central heating but would be much more suitable for a fire alarm.



In your answer you should link the information in the graph to the working of the sensor.

[3]

(d) In a different circuit, the PTC thermistor described by the graph in Fig. 11.2 is at an initial temperature of 20 °C, when it has a resistance of 260 Ω. A fault causes the current in this circuit to rise suddenly to 0.5 A.

(i) Calculate the rate at which energy is dissipated as heat in the thermistor immediately after the fault.

rate of dissipation of energy = W [2]

(ii) Explain why the current in this circuit quickly falls to a much smaller value.

[1]

[Total: 11]

[Section B Total: 41]

END OF QUESTION PAPER



Copyright Acknowledgements:

Q.2 Image © NASA/JPL/Space Science Institute, www.nasa.gov.

Permission to reproduce items where third-party owned material protected by copyright is included has been sought and cleared where possible. Every reasonable effort has been made by the publisher (OCR) to trace copyright holders, but if any items requiring clearance have unwittingly been included, the publisher will be pleased to make amends at the earliest possible opportunity.

OCR is part of the Cambridge Assessment Group. Cambridge Assessment is the brand name of University of Cambridge Local Examinations Syndicate (UCLES), which is itself a department of the University of Cambridge.