

**ADVANCED SUBSIDIARY GCE  
 PHYSICS B (ADVANCING PHYSICS)**

**2860**

Physics in Action

**THURSDAY 22 MAY 2008**

Afternoon  
 Time: 1 hour 30 minutes

Candidates answer on the question paper  
**Additional materials (enclosed):** None

**Additional materials (required):**  
 Data, Formulae and Relationships Booklet  
 Electronic calculator  
 Ruler (cm/mm)



Candidate Forename

Candidate Surname

Centre Number

Candidate Number

**INSTRUCTIONS TO CANDIDATES**

- Write your name in capital letters, your Centre Number and Candidate Number in the boxes above.
- Use blue or black ink. Pencil may be used for graphs and diagrams only.
- Read each question carefully and make sure that you know what you have to do before starting your answer.
- Answer **all** the questions.
- Do **not** write in the bar codes.
- Write your answer to each question in the space provided.

**INFORMATION FOR CANDIDATES**

- The number of marks for each question is given in brackets [ ] at the end of each question or part question.
- The total number of marks for this paper is **90**.
- You are advised to spend about 20 minutes on Section A, 40 minutes on Section B and 30 minutes on Section C.
- There are four marks for the quality of written communication in Section C.
- The values of standard physical constants are given in the Data, Formulae and Relationships Booklet. Any additional data required are given in the appropriate question.

FOR EXAMINER'S USE		
Section	Max.	Mark
A	20	
B	40	
C	30	
<b>TOTAL</b>	<b>90</b>	

This document consists of **18** printed pages and **2** blank pages.

Answer **all** the questions.

### Section A

- 1 Here is a list of units for electrical quantities.

**A s**

**A V<sup>-1</sup>**

**J C<sup>-1</sup>**

**J s<sup>-1</sup>**

Select the correct unit for

electrical charge .....

potential difference .....

electrical conductance .....

[3]

- 2 In a simple text messaging system, each of the 26 small letters of the alphabet: a, b, c.....y, z is coded as a different binary number.

- (a) State and explain the minimum number of bits required in each binary number to be able to code for these 26 alternatives.

number of bits = .....

Explanation:

[2]

- (b) Estimate the amount of information in a typical short text message in this system.

Make your method clear.

information = ..... bits [2]

**3**

- 3** An advanced digital colour display has a total of 18 million colour pixels. Each pixel requires a 12 bit number to control its colour intensity. These intensities can be altered 25 times per second.

Show that the rate of transmission of information, required to operate the colour display without data compression, is greater than  $5 \text{ Gbits s}^{-1}$ .

[1]

- 4** The lens of a fixed focus digital camera in a mobile phone is placed 8.0mm in front of the CCD (Charge Coupled Device) used to record the image of distant objects.

**(a)** Explain why the lens to image distance is approximately equal to the focal length  $f$  of the lens.

[2]

**(b)** Explain why this camera cannot form a clear image on the CCD of an object as close to the lens as 16.0mm.

You may use a diagram or calculation in your explanation.

[2]

- 5 Fig. 5.1 shows a graph of how the potential difference, p.d., across a cell varies with increasing current.

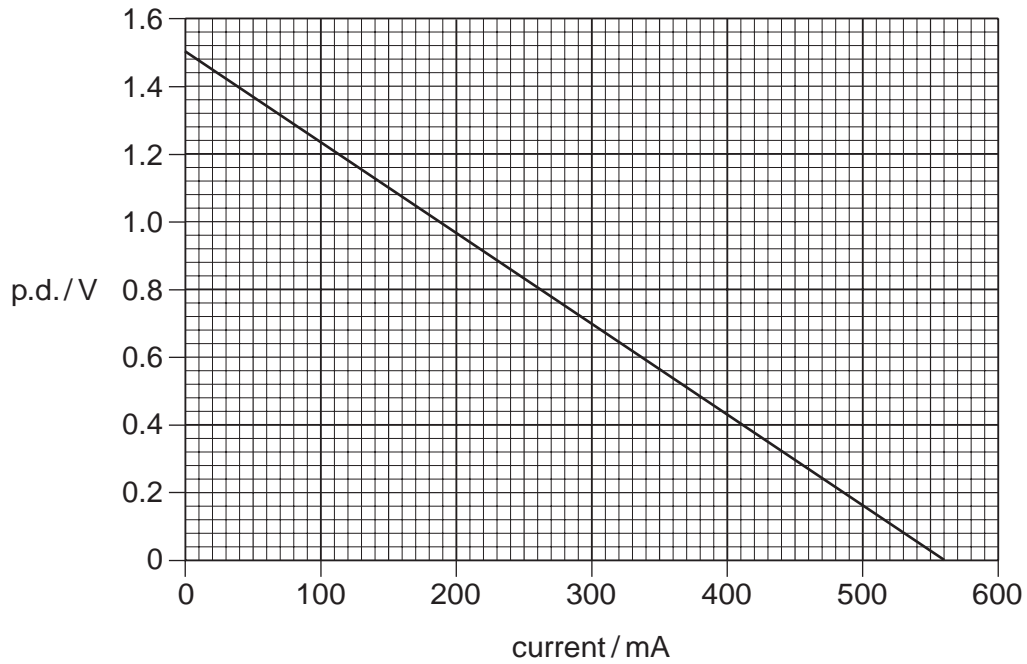

**Fig. 5.1**

- (a) From the graph read and record the following values:

the e.m.f. of the cell = ..... V

the maximum current obtainable from the cell = ..... mA

[2]

- (b) Use these data to calculate the internal resistance of the cell.

Make your method clear.

internal resistance = .....  $\Omega$  [2]

- 6 Explain why the tensile strength of a material is given as a stress measured in  $\text{Nm}^{-2}$  rather than as a force in N needed to break a specimen.

[2]

- 7 A spectrum analyser displays the intensity of sound in five frequency ranges from low (bass) to high (treble). Fig. 7.1 shows the display.

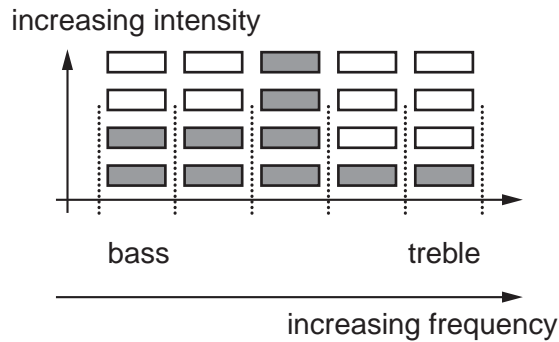

Fig. 7.1

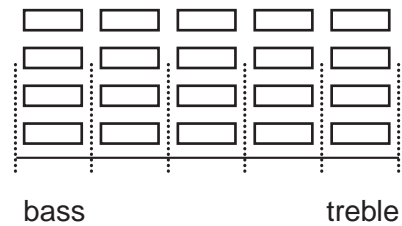

Fig. 7.2

More bars on the display shown in Fig. 7.1 light up when the sound in that frequency range is more intense. The lit up bars are shown as shaded.

Fig. 7.1 shows the display at one instant during the playback of a song on an audio system.

The listener then **reduces the bass** and **boosts the treble**.

Sketch on Fig. 7.2 a possible appearance of the spectrum analyser after this change, at the same instant of the new playback of the song.

[2]

[Section A Total: 20]

## Section B

- 8 This question is about a material called quantum tunnelling composite, or QTC. It consists of many separate randomly arranged metal particles of nano-metre size embedded in a matrix of long chain polymer molecules.

(a) Sketch a **labelled diagram** of the nano-structure of QTC to illustrate the description above.

[2]

- (b) When unstrained, the material has the resistivity  $\rho$  of a good insulator. For a small increase in stress, its resistivity drops logarithmically to near that of pure metals. This is illustrated in Fig. 8.1.

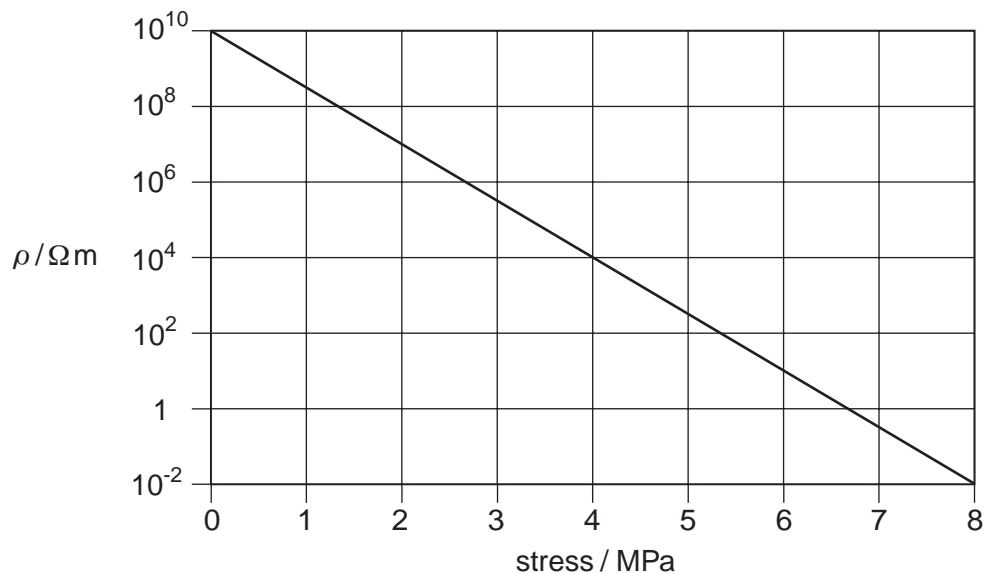

Fig. 8.1

- (i) Explain why the straight line graph indicates that the drop in resistivity is logarithmic with increasing stress.

[1]

- (ii) State the number of orders of magnitude by which the resistivity varies over the range of stresses shown.

orders of magnitude = ..... [1]

- (c) The QTC material is produced in “pills” that are 3.6 mm x 3.6 mm in cross section and 1.0 mm thick as illustrated in Fig. 8.2.

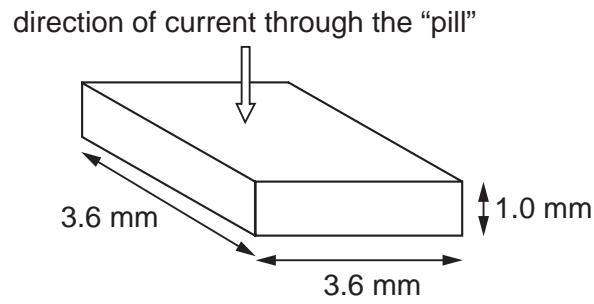

**Fig. 8.2**

- (i) Calculate the resistance of the pill when under a stress of 8.0 MPa. Use data from Fig. 8.1 and Fig. 8.2.

resistance = .....  $\Omega$  [3]

- (ii) Suggest a useful application for a QTC “pill” in a sensing circuit.

[1]

[Total: 8]

**[Turn over**

- 9 Fig. 9.1 shows how the resistance  $R$  of a light dependent resistor (LDR) in a circuit varies with light intensity incident upon it.

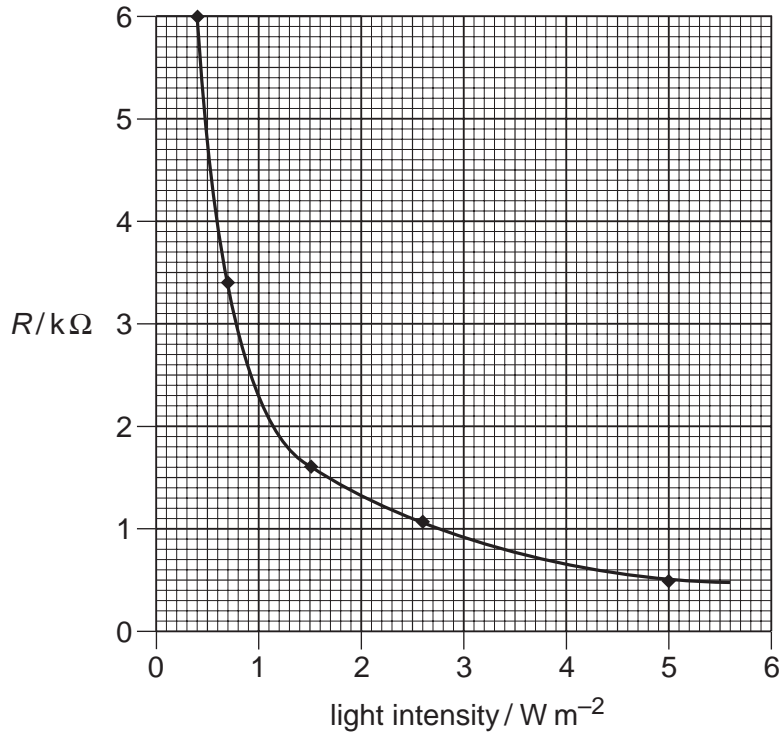

Fig. 9.1

- (a) Complete the following description of the graph.

As the light intensity incident upon the LDR decreases, its resistance .....

The change in resistance between  $1.0$  and  $1.5 W m^{-2}$  is less than  $1 k\Omega$

The change in resistance between  $0.5$  and  $1.0 W m^{-2}$  is about .....  $k\Omega$

On Fig. 9.1 the LDR shows **greatest** sensitivity to light intensity change

when the light intensity is .....

[3]

- (b) (i) The LDR and a fixed resistor are connected as a potential divider to the  $6.0V$  battery shown in Fig. 9.2 to make a circuit.  
Draw the potential divider on Fig. 9.2 to complete the circuit. The internal resistance of the battery can be neglected.

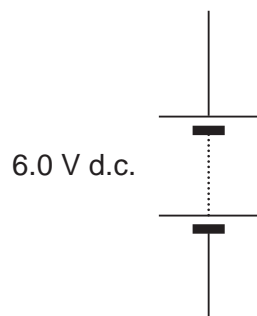

Fig. 9.2

[1]



- (ii) A voltmeter is to be connected to the circuit to indicate an **increasing** output p.d. when the sensor detects an **increasing** light intensity.

Add to Fig. 9.2 a voltmeter with the correct circuit connections to achieve this.

[1]

- (iii) An output p.d. of 3.0V is required from the circuit at a light intensity of  $1.0\text{Wm}^{-2}$ .

Calculate the value of the fixed resistor needed in the potential divider circuit to achieve this. Explain your reasoning.

resistance = .....  $\Omega$  [3]

- (c) For the same circuit, use Fig. 9.1 to predict the light intensity that would cause the output p.d. to rise to 4.0V. Explain your reasoning.

light intensity = .....  $\text{Wm}^{-2}$  [3]

[Total: 11]

10 Fig. 10.1 shows a stress-strain graph for a sample of metal which has been loaded and then unloaded.

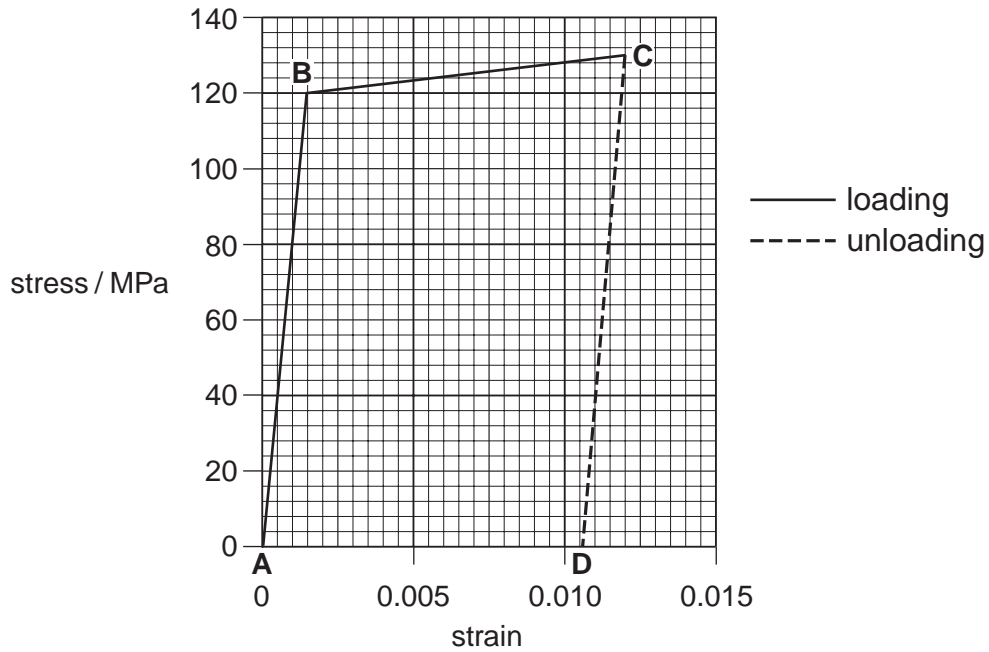

Fig. 10.1

(a) The graph Fig. 10.1 can be divided into three sections **AB**, **BC** and **CD**.

- (i) Name the section(s) that show **elastic** behaviour .....
- (ii) Name the section(s) that show **plastic** behaviour .....

[3]

(b) State from the graph Fig. 10.1

- (i) the yield stress of the metal

yield stress = ..... MPa [1]

- (ii) the permanent strain of the metal after the load is removed.

strain = ..... [1]

(c) Calculate the Young modulus of the metal in MPa using data from Fig. 10.1.

Make your method clear.

Young modulus = ..... MPa [3]

(d) Explain the difference between elastic and plastic behaviour in a metal in terms of the arrangement and movement of the atoms in a metal.

Labelled diagrams may help to illustrate your answer.

[3]

[Total: 11]

**[Turn over**

11 This question is about the use of high-power light emitting diodes (LEDs) in traffic lights.

Fig. 11.1 shows the graph of current against potential difference for a high-power red LED.

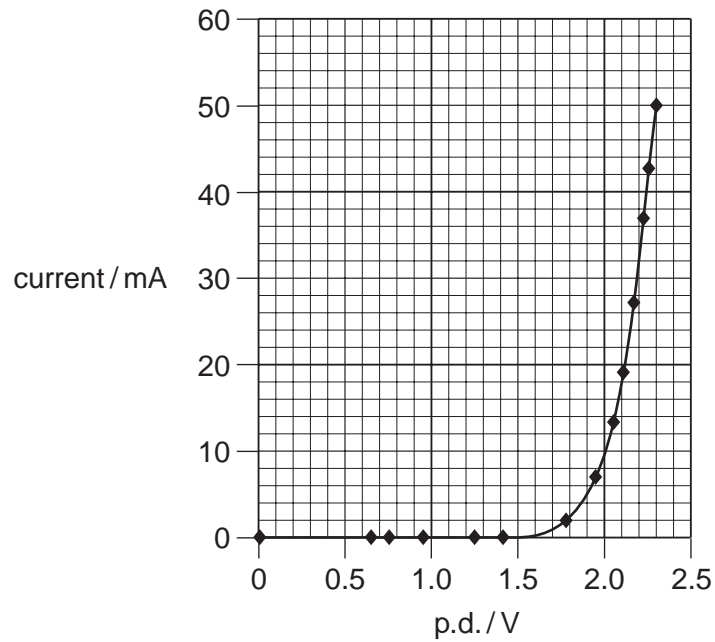

Fig. 11.1

(a) (i) Describe the variation of current with p.d. shown in Fig. 11.1.

[2]

(ii) Use data from the graph to show that the electrical power supplied to the red LED when operating at 50 mA is greater than 100 mW.

[2]

(iii) State where the energy of the electrons passing through the LED goes.

[1]

(b) Fig. 11.2 shows part of the array of 105 red LEDs that make the red disc of a traffic light.

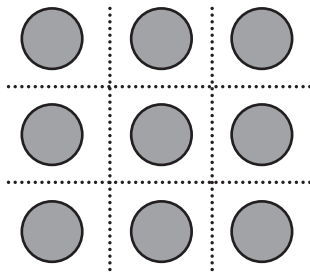

Fig. 11.2

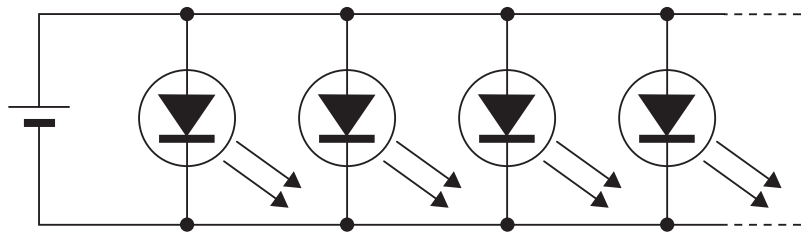

Fig. 11.3

- (i) The 105 LEDs are connected in a parallel circuit as shown in Fig. 11.3. Suggest a reason why the LEDs are connected in parallel.

[1]

- (ii) Calculate the total power in W for all 105 LEDs when each is operating at 50 mA.

total power = ..... W [1]

- (iii) 150W of electrical power is required by a filament lamp to give a similar power output of red light.

Suggest **two** reasons why a filament lamp requires so much more power to give the same red light output.

[2]

- (iv) Filament lamps are often used in traffic lights. Suggest a benefit to society of substituting LEDs for filament lamps in traffic lights.

[1]

[Total: 10]

[Section B Total: 40]

[Turn over

## Section C

In this section, you will choose the context in which you give your answers.

Use diagrams to help your explanations and take particular care with your written English. In this section four marks are available for the quality of written communication.

**12** In this question you are asked to choose and discuss an image containing useful information formed from radiation of some kind. Your example should be one where image-processing could improve or enhance the image in some way.

**(a) (i)** Identify your chosen image .....

**(ii)** The radiation used to form this image will have an appropriate frequency and wavelength. Name the radiation and give estimates of the frequency and wavelength used.

radiation

frequency

wavelength

[3]

**(iii)** Calculate the product (frequency  $\times$  wavelength) for this radiation, giving appropriate units.

frequency  $\times$  wavelength = ..... unit ..... [2]

**(iv)** State clearly the physical significance of the product defined in **(iii)** above.

[1]

**(b)** State a use that could be made of the information contained in your image.

[1]

- (c) Describe the system that forms your image.  
A labelled diagram will be useful in your answer.

[3]

- (d) Images can often be improved by image processing.

Describe how processing, for example by modifying pixel values, could improve your image.

[3]

[Total: 13]

**[Turn over**

13 In this question you are asked to choose and discuss an application of signal transmission.

(a) State your example of signal transmission and the nature of the information that could be carried.

example of signal transmission .....

nature of information carried ..... [1]

(b) (i) Communications systems can transmit information by **digital** or **analogue** signals (or a combination).

Explain the difference between digital and analogue signals, using sketch graphs to illustrate your answer.

[3]

(ii) To convert from analogue to digital signals, the signal is **sampled** and then **digitised**.

Explain the terms sampling and digitising.

You may find a diagram useful in your explanation.

[3]



- (iii) When analogue signals are reconstructed from digital signals, some of the original information can get lost or corrupted.

State and explain **two** ways in which these errors can occur.

[3]

- (c) Discuss the effects on individuals and/or society if the signal transmission system you have described had **not** been invented.

[3]

[Total: 13]

[Quality of Written Communication: 4]

[Section C Total: 30]

**END OF QUESTION PAPER**

**BLANK PAGE**

**PLEASE DO NOT WRITE ON THIS PAGE**

**19**  
**BLANK PAGE**

**PLEASE DO NOT WRITE ON THIS PAGE**

**PLEASE DO NOT WRITE ON THIS PAGE**

---

Permission to reproduce items where third-party owned material protected by copyright is included has been sought and cleared where possible. Every reasonable effort has been made by the publisher (OCR) to trace copyright holders, but if any items requiring clearance have unwittingly been included, the publisher will be pleased to make amends at the earliest possible opportunity.

OCR is part of the Cambridge Assessment Group. Cambridge Assessment is the brand name of University of Cambridge Local Examinations Syndicate (UCLES), which is itself a department of the University of Cambridge.