

<b>Candidate Forename</b>		<b>Candidate Surname</b>	
-------------------------------	--	------------------------------	--

<b>Centre Number</b>						<b>Candidate Number</b>				
--------------------------	--	--	--	--	--	-----------------------------	--	--	--	--

**OXFORD CAMBRIDGE AND RSA EXAMINATIONS  
ADVANCED SUBSIDIARY GCE**

**G482**

**PHYSICS A**

**Electrons, Waves and Photons**

**WEDNESDAY 13 JANUARY 2010: Morning**

**DURATION: 1 hour 45 minutes**

**SUITABLE FOR VISUALLY IMPAIRED CANDIDATES**

**Candidates answer on the Question Paper**

**OCR SUPPLIED MATERIALS:**

**Data, Formulae and Relationships Booklet**

**OTHER MATERIALS REQUIRED:**

**Electronic calculator**

**READ INSTRUCTIONS OVERLEAF**

## **INSTRUCTIONS TO CANDIDATES**

- Write your name clearly in capital letters, your Centre Number and Candidate Number in the boxes on the first page.
- Use black ink. Pencil may be used for graphs and diagrams only.
- Read each question carefully and make sure that you know what you have to do before starting your answer.
- Answer **ALL** the questions.
- Write your answer to each question in the space provided, however additional paper may be used if necessary.

## **INFORMATION FOR CANDIDATES**

- The number of marks is given in brackets [ ] at the end of each question or part question.
- The total number of marks for this paper is **100**.



Where you see this icon you will be awarded marks for the quality of written communication in your answer.

This means, for example, you should

- ensure that text is legible and that spelling, punctuation and grammar are accurate so that meaning is clear;
- organise information clearly and coherently, using specialist vocabulary when appropriate.
- You may use an electronic calculator.
- You are advised to show all the steps in any calculations.

**BLANK PAGE**

**Answer ALL the questions.**

- 1 (a) A 12V 36W lamp is lit to normal brightness using a 12V car battery of negligible internal resistance. The lamp is switched on for one hour (3600 s). For the time of 1 hour, calculate**

- (i) the energy supplied by the battery**

**energy = \_\_\_\_\_ J [2]**

- (ii) the charge passing through the lamp**

**charge = \_\_\_\_\_ unit\_\_\_\_\_ [3]**

- (iii) the total number of electrons passing through the lamp.**

**number of electrons = \_\_\_\_\_ [2]**

(b) The wires connecting the 36W lamp to the 12V battery are made of copper. They have a cross-sectional area of  $1.1 \times 10^{-7} \text{ m}^2$ . The current in the wire is 3.0 A. The number  $n$  of free electrons per  $\text{m}^3$  for copper is  $8.0 \times 10^{28} \text{ m}^{-3}$ .

(i) Describe what is meant by the term *mean drift velocity* of the electrons in the wire.

---

---

---

[2]

(ii) Calculate the mean drift velocity  $v$  of the electrons in this wire.

$$v = \text{_____} \text{ m s}^{-1} \text{ [3]}$$

[Total: 12]

2 (a) Define the *resistivity*  $\rho$  of a metal wire.

---

---

---

[2]

(b) In the UK the National Grid is used to transmit electric power. Each pylon supports 24 cables. See Fig. 2.1. Each cable consists of 38 strands of aluminium. See Fig. 2.2.

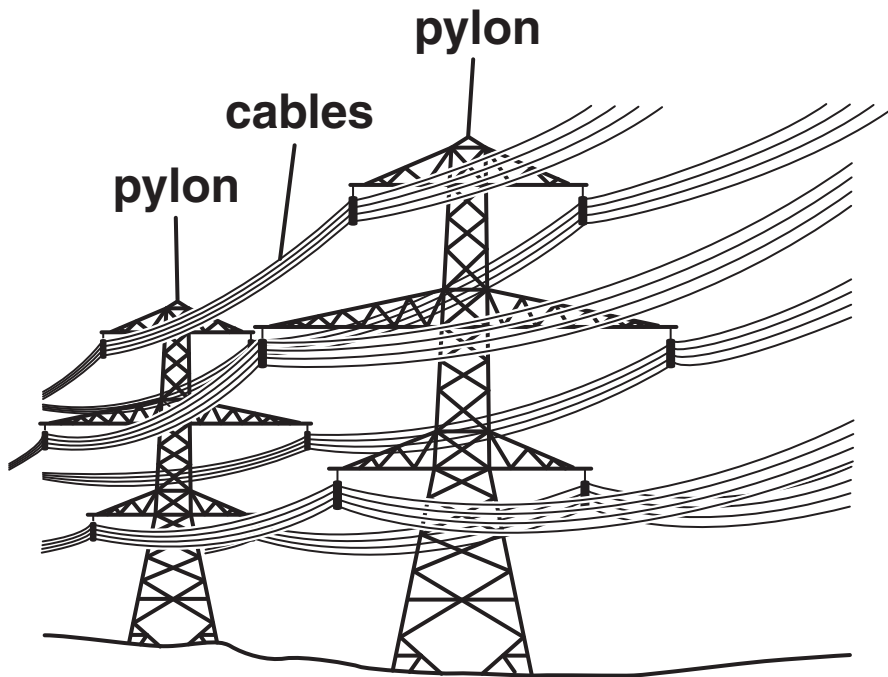
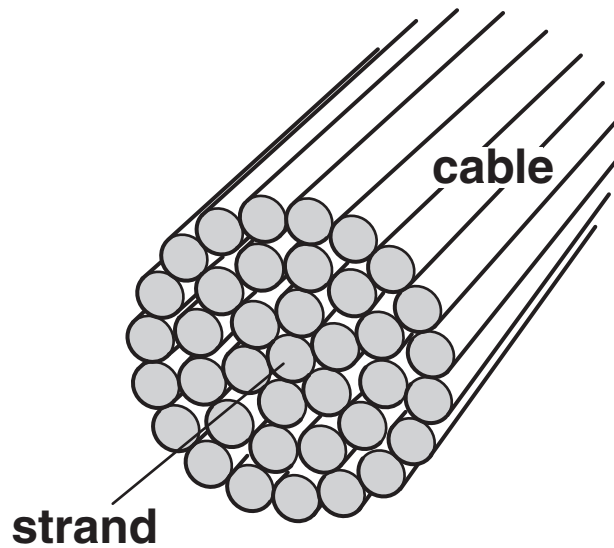

Fig. 2.1



**Fig. 2.2**

- (i) The resistance per km of a cable is  $0.052 \Omega \text{ km}^{-1}$ . Explain why the resistance per km of a single strand is approximately  $2.0 \Omega \text{ km}^{-1}$ .

---



---



---

[2]

- (ii) The resistivity of aluminium is  $2.6 \times 10^{-8} \Omega \text{ m}$ . Calculate the cross-sectional area  $A$  of a single strand of the cable.

$A = \text{_____} \text{ m}^2$  [2]

**(c) The input voltage to each cable in Fig. 2.1 is 400 kV. The cable carries a current of 440 A. Calculate**

**(i) the input power to one cable**

**input power = \_\_\_\_\_ W [2]**

**(ii) the number of cables required to transmit the power from a 2000 MW power station**

**number of cables = \_\_\_\_\_ [1]**

**(iii) the power lost as heat per km of cable**

**lost power = \_\_\_\_\_ [3]**

**(iv) the percentage of the input power that is available at a distance of 100 km from the power station.**

**percentage of power = \_\_\_\_\_ % [2]**

**[Total: 14]**



**BLANK PAGE**

- 3 Fig. 3.1 shows a circuit containing a battery of e.m.f. 12V, two resistors, a light-dependent resistor (LDR), an ammeter and a switch S. The battery has negligible internal resistance.

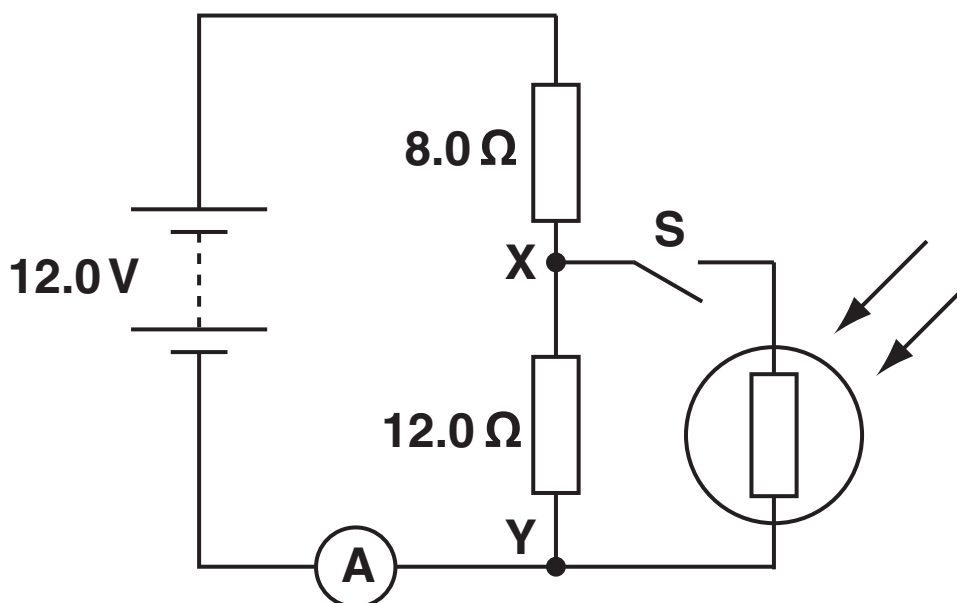

Fig. 3.1

- (a) When the switch S is open, show that the potential difference between the points X and Y is 7.2V.

[2]

**(b) The switch S is now closed. Describe and explain the change to each of the following when the intensity of light falling on the LDR is increased:**

**(i) the ammeter reading**

---

---

---

**[2]**

**(ii) the potential difference across XY.**

---

---

---

**[2]**

**[Total: 6]**

- 4 (a) Fig. 4.1 shows the  $I$ - $V$  characteristic of a light-emitting diode (LED).

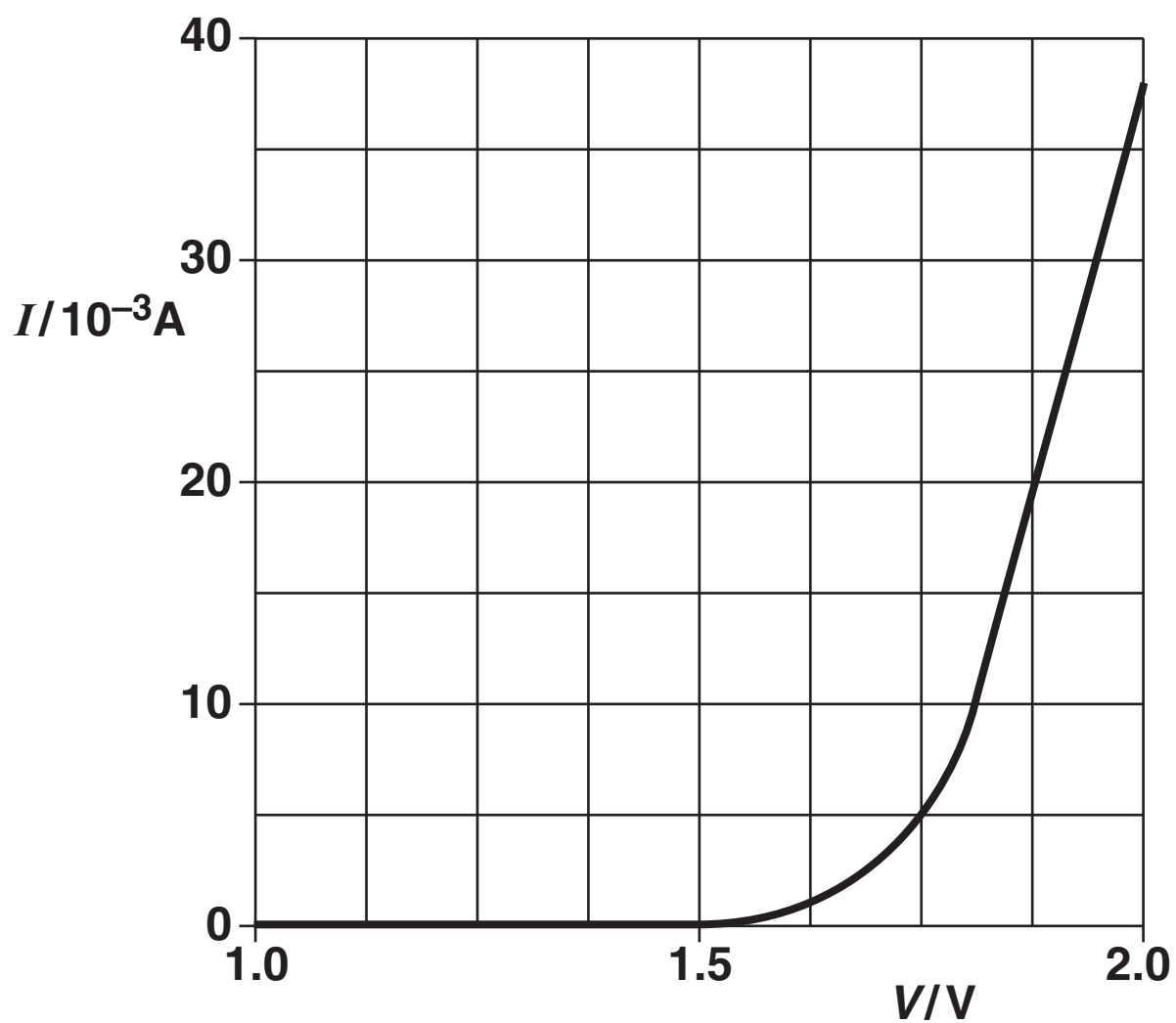

Fig. 4.1



- (b) In order to carry out an investigation to determine the  $I$ - $V$  characteristic of an LED a student connects the circuit shown in Fig. 4.2.

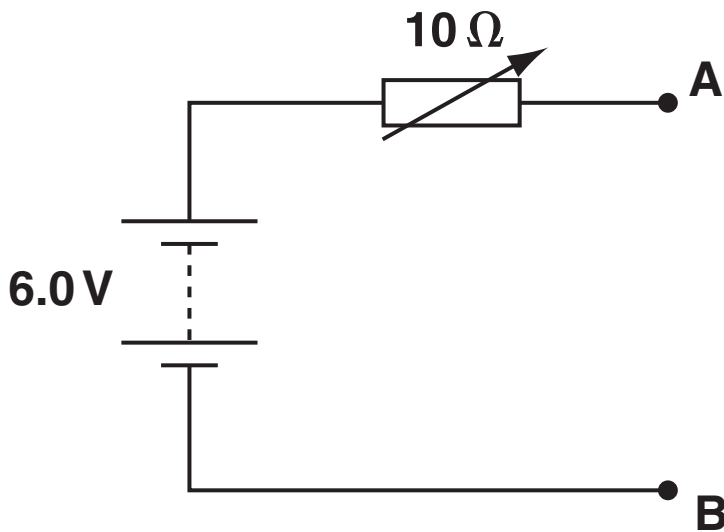

Fig. 4.2

On Fig. 4.2 add an LED with a  $100\ \Omega$  resistor in series, an ammeter and a voltmeter to complete the circuit between terminals A and B. [3]

- (c) When designing a circuit which includes an LED, it is normal practice to connect a resistor in series with the LED, in this case  $100\ \Omega$ . Suggest and explain the purpose of this resistor.

---

---

---

[2]

- (d) Another student uses the  $10\ \Omega$  variable resistor as a potentiometer (potential divider) as shown in Fig. 4.3. The rest of the circuit is then completed between terminals A and B as for Fig. 4.2 in (b).

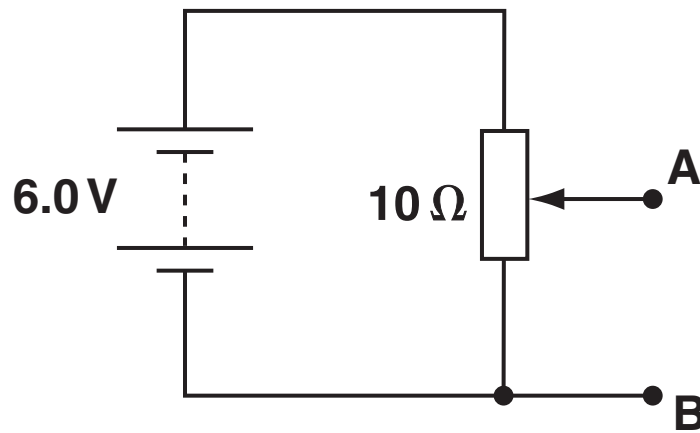

Fig. 4.3

Explain why the circuit of Fig. 4.3 is more suitable for obtaining the  $I$ - $V$  characteristic of the LED than the circuit of Fig. 4.2.

---

---

---

---

---

---

[3]

[Total: 16]

- 5 (a) (i) Define the terms *wavelength*, *frequency* and *speed* used to describe a progressive wave.

*wavelength,  $\lambda$*  \_\_\_\_\_  
\_\_\_\_\_

*frequency,  $f$*  \_\_\_\_\_  
\_\_\_\_\_

*speed,  $v$*  \_\_\_\_\_  
\_\_\_\_\_

[3]

- (ii) Hence derive the wave equation  $v = f\lambda$  which relates these terms together.

[2]



**(b) (i) Explain what is meant by *infra-red radiation*.**

---

---

---

[2]

**(ii) For infra-red radiation emitted at a frequency of  $6.7 \times 10^{13}$  Hz, calculate**

**1 its wavelength**

**wavelength = \_\_\_\_\_ m [2]**

**2 its period of oscillation.**

**period = \_\_\_\_\_ s [2]**

- (iii) Infra-red radiation is absorbed by molecular ions in a crystal causing them to vibrate at a frequency of  $6.7 \times 10^{13}$  Hz. The amplitude of oscillation of the ions is  $8.0 \times 10^{-12}$  m.

On the grid of Fig. 5.1 sketch a graph showing the variation with time of the displacement of an ion.

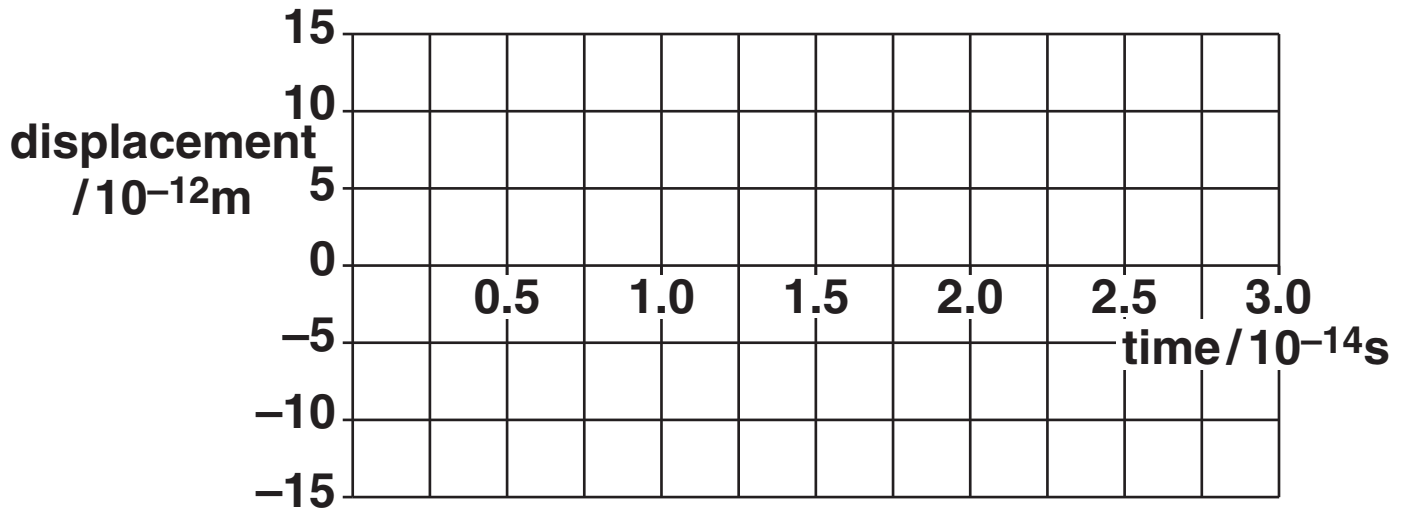

Fig. 5.1

[3]

[Total: 14]

- 6 (a) Interference of waves from two sources can only be observed when the waves are coherent.

Explain the meaning of

(i) *interference*

---

---

---

[2]

(ii) *coherence.*

---

---

[1]

- (b) Fig. 6.1 shows two microwave transmitters A and B 0.20 m apart. The transmitters emit microwaves of equal amplitude in phase and of wavelength 30 mm. A detector, moved along the line PQ at a distance of 5.0 m from AB, detects regions of high and low intensity forming an interference pattern.

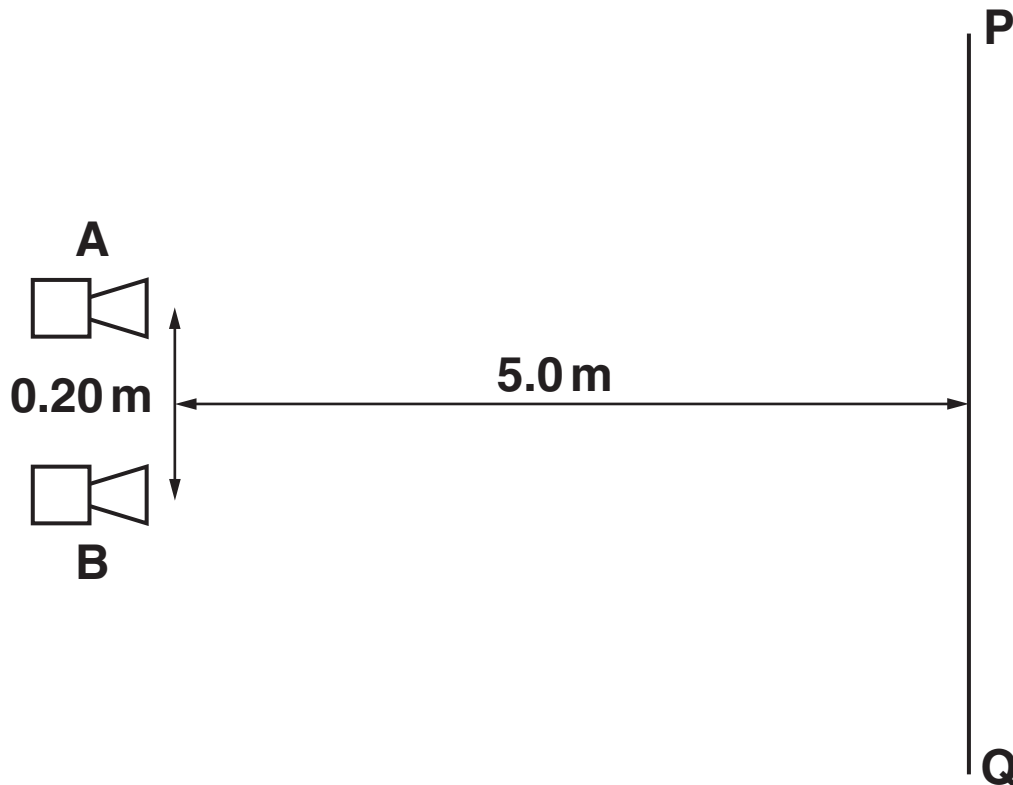

Fig. 6.1

- (i) Use the ideas of path difference or phase difference to explain how the interference pattern is formed.

---

---

---

---

---

---

---

---

---

---

[3]

- (ii) Calculate the separation between one region of high intensity and the next along the line PQ.

separation = \_\_\_\_\_ m [2]

**(iii) State the effect, if any, on the position and intensity of the maxima when each of the following changes is made, separately, to the experiment.**

**1 The amplitude of the transmitted waves is doubled.**

---

---

---

**[2]**

**2 The separation between the transmitters is halved.**

---

---

---

**[2]**

**3 The phase of transmitter A is reversed so that there is now a phase difference of  $180^\circ$  between the waves from A and B.**

---

---

---

**[2]**

**[Total: 14]**

**7 (a) A helium-neon laser emits red light of wavelength  $6.3 \times 10^{-7}$  m.**

**(i) Show that the energy of a single photon is about  $3 \times 10^{-19}$  J.**

**[2]**

**(ii) The power of the laser beam is 1.0 mW. Show that about  $3 \times 10^{15}$  photons are emitted by the laser each second.**

**[1]**

- (iii) The photons of red light are emitted by the neon atoms in the gas inside the laser.

Explain what *energy levels* are and how they can be used to explain the emission of photons from atoms.



*In your answer take care to make your explanation clear.*

---

---

---

---

---

---

---

---

---

---

---

---

[4]



- (iv) Another laser emits blue light. The power in its beam is also 1.0 mW.

**Explain why the laser emitting blue light emits fewer photons per second compared with a laser of the same power emitting red light.**

---

---

---

[2]

(b) A photodiode is a circuit component which can be used to convert a light signal into an electrical one. Fig. 7.1 shows an enlarged cross-section through a photodiode to illustrate how it is constructed. Light incident on the thin transparent conducting surface layer of the diode passes through it to be absorbed in the insulating layer. The energy of each photon is sufficient to release one electron in the insulating layer. The potential difference  $V$  applied across the insulating layer causes these electrons to move to one of the conducting layers.

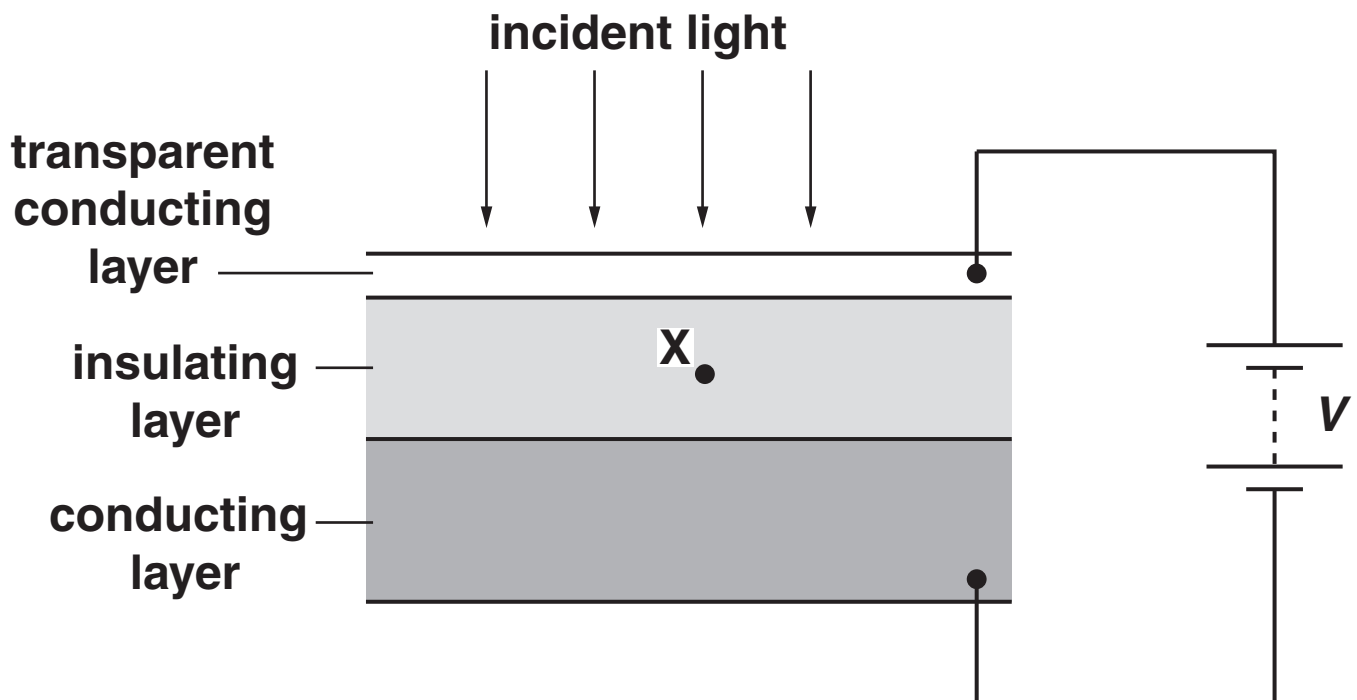

Fig. 7.1

- (i) Draw an arrow on Fig. 7.1 to show the direction of motion of an electron released at point X in the centre of the insulating layer. [1]

- (ii) The red light from the laser in (a) is incident on the photodiode. Experiments show that only 20% of the red light photons release electrons in the insulating layer and hence in the circuit of Fig. 7.1. Calculate the current through the photodiode.

current = \_\_\_\_\_ A [3]

- (iii) Suggest one reason why the efficiency of the photodiode is less than 100%.

\_\_\_\_\_  
\_\_\_\_\_ [1]

[Total: 14]

**8 In 1927 it was shown by experiment that electrons can produce a diffraction pattern.**

**(a) (i) Explain the meaning of the term *diffraction*.**

---

---

---

**[1]**

**(ii) State the condition necessary for electrons to produce observable diffraction when passing through matter, e.g. a thin sheet of graphite in an evacuated chamber.**

---

---

---

---

**[2]**

**(b) Show that the speed of an electron with a de Broglie wavelength of  $1.2 \times 10^{-10}$  m is  $6.0 \times 10^6$  m s<sup>-1</sup>.**

**[3]**

- (c) The electrons in (b) are accelerated to a speed of  $6.0 \times 10^6 \text{ m s}^{-1}$  using an electron gun shown diagrammatically in Fig. 8.1.

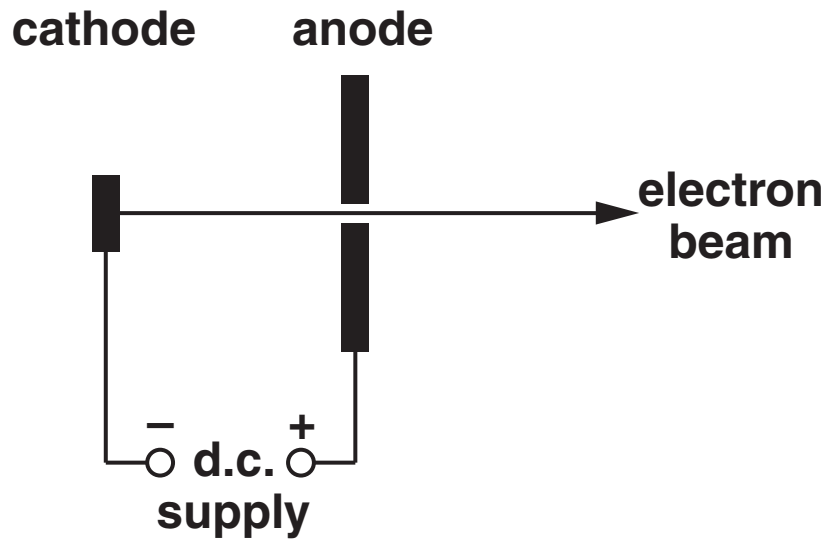

Fig. 8.1

- (i) Calculate the potential difference  $V$  across the d.c. supply between the cathode and the anode.

$V =$  \_\_\_\_\_ V [3]

- (ii) Suggest why, in an electron gun, the cathode is connected to the negative terminal of the supply rather than the positive terminal.**

---

---

---

**[1]**

**[Total: 10]**

**END OF QUESTION PAPER**



## **Copyright Information**

**OCR is committed to seeking permission to reproduce all third-party content that it uses in its assessment materials. OCR has attempted to identify and contact all copyright holders whose work is used in this paper. To avoid the issue of disclosure of answer-related information to candidates, all copyright acknowledgements are reproduced in the OCR Copyright Acknowledgements Booklet. This is produced for each series of examinations, is given to all schools that receive assessment material and is freely available to download from our public website ([www.ocr.org.uk](http://www.ocr.org.uk)) after the live examination series.**

**If OCR has unwittingly failed to correctly acknowledge or clear any third-party content in this assessment material, OCR will be happy to correct its mistake at the earliest possible opportunity.**

**For queries or further information please contact the Copyright Team, First Floor, 9 Hills Road, Cambridge CB2 1GE.**

**OCR is part of the Cambridge Assessment Group; Cambridge Assessment is the brand name of University of Cambridge Local Examinations Syndicate (UCLES), which is itself a department of the University of Cambridge.**