

**ADVANCED GCE UNIT
PHYSICS A**

2826/03/INST

Practical Examination 2 Instructions for the Planning Exercise and Practical Test

To be opened immediately

Planning Exercise – for issue on or after:

THURSDAY 15 MARCH 2007

Practical Test:

MONDAY 21 MAY 2007

1 hour 30 minutes



* C O P / T 2 4 7 6 1 *

This document is for the **Head of Centre** and for the use of the **Physics teacher and/or technician** who prepares the apparatus and materials for the examination.

A packet containing **two** copies of the Physics Practical Test, 2826/03/TEST, accompanies the packet containing these Instructions.

These documents should be issued to the Physics teacher immediately they arrive at the Centre, but they **must be kept in a secure place at all times**.

These documents are provided so that the Physics teacher and/or technician can ensure that the Centre's apparatus is suitable for carrying out the Physics Practical Test.

Great care should be taken that any confidential information given here does not reach the candidates, either directly or indirectly.

This document consists of **9** printed pages, **1** blank page and a Supervisor's Report.

PLANNING EXERCISE

The Planning Exercise should be issued to candidates on or after the date shown on the front of this document. The candidates' plans must be collected in, on or before the date of the Practical Test. These arrangements may be made at the discretion and convenience of the Centre.

It should be recognised that each Planning Exercise makes only a small contribution to the overall assessment and candidates should therefore be guided to spend an appropriate amount of time on the work. Candidates should be given between **7 and 10 days** to complete it.

The mark scheme for the Planning Exercise is based closely on the coursework mark descriptors for Skill P given in the Specification and a copy of these descriptors should be made available to candidates to assist them in their work.

Candidates may be given access, if they request it and at the discretion of the Centre, to laboratory space and facilities in order to be able to carry out preliminary work which will help in constructing their Plan. However, it should be noted that the responsibility for Health and Safety during this period rests with the Centre, and the attention of teachers is drawn to the Health and Safety section in the Specification. Access to suitable library and other resources may also be required and, while time at home or in private study will be necessary to complete the task to a high standard, sufficient work must be completed under direct supervision to allow the teacher to authenticate the work with confidence as that of the candidates concerned. Many Centres find that this can best be managed by allowing candidates a set period of time to research the topic but requiring the Plan to be written under supervision. The supervising teacher should complete the statement of authentication for each candidate on the front cover page of the Plan. Details should be provided on the Supervisor's Report for the Practical Test of any assistance given to candidates.

After candidates' work has been collected, it must be kept securely until the date of the Practical Test (or must be collected on the day of the Practical Test) and must be included with the scripts for the Practical Test when these are despatched to the Examiner. Please tie together **loosely** (or use a treasury tag) the Planning Exercise and Practical Test for each candidate **with the Practical Test on the top**.

Guidance for Teachers/Tutors on authenticating work

The work submitted by candidates for assessment must be entirely their own.

Candidates may however:

- quote from books or any other source; this should be referenced in the work and all sources acknowledged;
- receive guidance from someone other than their teacher/tutor; the course teacher must be informed of the name of the person giving external guidance and the nature of the assistance given;
- produce work at a location away from the examination Centre provided that the work remains under the supervision of the teacher/tutor.

In cases of privately entered candidates or distant tutored candidates, the Centre must ensure that:

- the teacher/tutor has acquainted themselves thoroughly with the general standard of candidates' work before accepting work for assessment;
- sufficient on-going regular monitoring of candidates' work has taken place.

Before authenticating work, the teacher/tutor should ask themselves the following basic questions.

- Has the **Declaration by candidate** been signed by the candidate?
- Was at least part of the work done under your direct supervision?
- Did you check the work during its production?
- Is the standard of finished work consistent with your professional judgement of the candidate's ability?

If you have answered 'YES' to the above questions you may authenticate the work.

The following notes for guidance are issued to candidates

- 1 Your Plan should have a clear and helpful structure and should be illustrated by diagrams, tables, charts, graphs etc. as appropriate. Remember that these can often be used to replace words in the text. Diagrams should be relevant to the content of your plan and positioned appropriately. Labels on diagrams, flow charts or tables should be clear and concise. Large blocks of text should be included in the word count.
- 2 You should take care to use technical and scientific terms correctly and to write in clear and correct English.
- 3 Your Plan should be hand-written or word-processed on A4 paper, which should have a hole punched at the top left hand corner. Pages should be numbered and should have a clear margin on the right hand side. You should write (or print) on one side of the paper only and each sheet should be marked with your Centre number and Candidate number.
- 4 You should show that you have consulted an appropriate range and variety of sources. At the end of your Plan you should list clearly the sources you have used. You should refer to these references in your Plan where appropriate. Where you have incorporated material which has been *copied directly* from a source such as a book or the Internet, this must be acknowledged in your Plan and details included in the references at the end. However, it should be noted that the inclusion of copied material will not in itself gain credit. The list of references should not be included in the word count.
- 5 Your Plan should be based on the use of standard equipment, apparatus, chemicals and other materials available in a school or college science laboratory.
- 6 Your Plan should be of about **500** words. A plan which is in excess of 500 words is likely to have poor structure and unselective choice of material, so that full credit may not be available. You should indicate the number of words in the margin of the Plan at approximately 100 word intervals.
- 7 When you have finished, tie the pages **loosely** together, with this sheet on the top, so that the pages turn over freely, or use a treasury tag. Your Centre will give you the date by which your Plan must be handed in.

PRACTICAL TEST

General Instructions

The examination paper contains two compulsory practical questions. Centres must make suitable arrangements so that candidates are able to begin a second experiment when they choose to do so and not be kept waiting after they have finished the first experiment. Instructions as to how this is to be achieved must be given to candidates at the start of the examination. Spare sets of apparatus for both experiments should be available in case of equipment failure.

It is advisable to set out the apparatus and materials for the examination at least one day before the examination is to commence. Unauthorised persons are not permitted to enter the laboratory during this time. The laboratory must be kept locked until the start of the examination.

The Physics teacher should be granted access to the question paper in advance in order to be satisfied that the apparatus provided is in accordance with these instructions and are fully suitable for the performance of the experiments. To this end, the Physics teacher and/or technician is required to perform the experiments well in advance of the examination and then to submit with the Supervisor's Report a sample set of results in the same form as that expected of the candidates.

Candidates must be instructed to write all their answers in the question booklet. Working must be shown. The use of scrap paper is not permitted.

It is assumed that candidates will provide themselves with such standard items as a calculator, pencil and 30 cm rule.

Whenever a stopwatch or stopclock is specified, candidates should be advised, in advance, that they may, if they wish, use wristwatches with stopwatch facilities.

Candidates should be informed that, if they find themselves in real difficulty, they may ask the Supervisor for assistance but the extent of this assistance will be reported to the Examiner, who may make a deduction of marks. If the Supervisor becomes aware that a candidate is having difficulty, then the Supervisor is expected to give the minimum amount of help required to enable the candidate to obtain a set of results from the apparatus. A note of the type of help given should be made in the Supervisor's Report on the last page of these instructions. The names and index numbers of these candidates must be included. **Under no circumstances should help be given to candidates with the presentation or analysis of experimental data.**

In cases of faulty apparatus (not arising from a candidate's mishandling) which prevents the required readings from being taken, extra time must be allowed so that the candidate has a fair opportunity of performing the experiment as though the fault had not been present. Details of such cases of time compensation should be given in the comments section in the Supervisor's Report.

If the apparatus or materials which have been provided differ significantly from the specifications in these instructions then full details of the changes must be given in the Supervisor's Report. Candidates will not be disadvantaged provided that the nature of the experiments has not been changed. Supervisors are advised to contact the Board well before the date of the examination if, for example, there are difficulties with obtaining particular pieces of apparatus.

Cases of individual hardship, e.g. illness, disability, etc. should be reported direct to OCR on the 'Special Considerations' form and **not** included with the Supervisor's Report.

At the end of the examination each candidate's answer to the Planning Exercise must be tied loosely to the appropriate candidate's booklet.

Supervisors must give any required information on the Supervisor's Report form at the back of these instructions. This report must be signed and dated. The Centre Name and Centre Number must also be included. **It is essential that this form is sent with candidates' scripts.** It may be necessary to make copies of the Supervisor's Report for attachment to individual scripts. If the scripts are to be despatched in more than one envelope, it is **essential** that a copy of the Supervisor's Report is enclosed in **each** envelope.

HEALTH AND SAFETY

Attention is drawn to the section on Health and Safety in Appendix B of the Physics A Specification, which covers practical tests as well as coursework. Centres are reminded that, in UK law, the responsibility for Health and Safety lies with the employer.

Materials used in the examination should display appropriate hazard symbols.

The Supervisor should intervene if he or she feels that a candidate is working in an unsafe manner. A **brief report** of the circumstances of any such intervention **must** be sent to the Examiner, in the Supervisor's Report.

INSTRUCTIONS TO SUPERVISORS

Question 1

Candidates will be required to investigate how light is absorbed by a stack of microscope slides. The output of a photovoltaic cell will be measured for different numbers of slides (2 to 20), between the cell and the light source.

The apparatus will be arranged as follows:

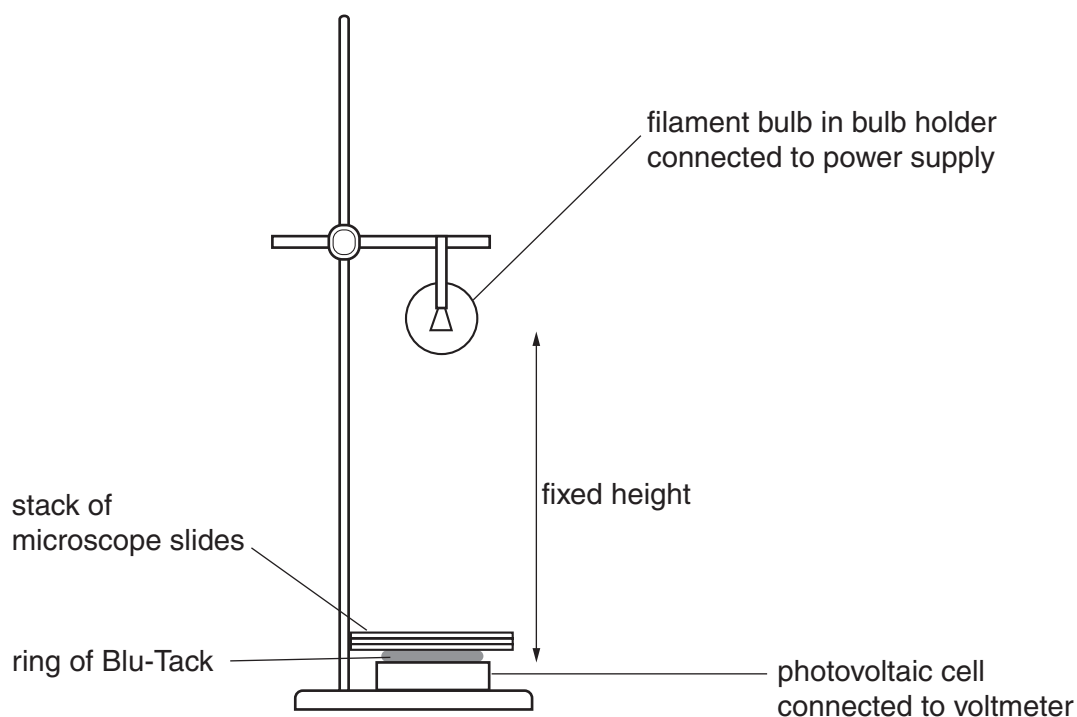

Fig. 1.1

Apparatus requirements (per set of apparatus unless otherwise specified).

- Suitably mounted photovoltaic cell (solar cell), max output 450mV, e.g. Solar cell 0.45V (100mA) Cat. No 37 – 0430 from Rapid in Education, or similar. Blu-Tack can be used if necessary to mount the cell.
- 12V, 24W or 36W bulb, connected to power supply.
- Digital voltmeter, range at least 0 to 100mV, reading to 1 mV, **OR**, an analogue voltmeter of the same range reading to the nearest 2 mV or better. In trials, UNILAB 081.117 was found to be suitable. The full-scale deflection value for the voltmeter should be made clear.
- Sufficient electrical leads.
- 20 microscope slides. (In trials, slides of thickness 1.17 mm were used).
- Blu-Tack, soft enough to be easily shaped.
- Clamp, boss and clamp stand, if not supplied with bulb.
- Micrometer screw gauge. It is permitted to share this between up to four candidates if necessary.

The bulb should be set **by the supervisor** at a height of about 10 cm above the cell. The bulb voltage should be adjusted to give just below full scale deflection on the voltmeter, with no slides present. These settings should **not** be altered by the candidate. The Blu-Tack, cell and slides should then be removed and laid out on the bench ready to use.

If the apparatus is to be used by a second candidate, the Blu-Tack, cell and slides should be removed and laid out on the bench ready for the next candidate to use. Check that the photocell surface and the slides are clean, and that the maximum voltmeter reading is just below full-scale deflection.

Procedure to be followed by candidates

Candidates will assemble the apparatus as shown, and will then measure the photovoltaic cell output voltage (V) for different numbers of microscope slides (n) placed on top of the mounted cell. A ring of Blu-Tack, about 5 mm high, shaped so as to surround the cell, will shield the cell from unwanted light and also act as a non-slip horizontal surface for the slides. The slides should be kept clean and free from fingerprints. The graph of $\ln(V)$ plotted against the number of slides n should be a straight line.

Question 2**Apparatus requirements (per set unless otherwise specified)**

- Spring 220 mm long and 6 mm diameter, as supplied by Griffin Cat no XBV 460-Q.
- 100 g mass holder and five further 100 g masses (to make total masses of 0.3 kg and 0.6 kg).
- Stop watch measuring to 0.01 s.
- Clamp, boss and clamp stand.
- G-clamp, to clamp the clamp stand to the bench.

The apparatus should be assembled so that when the 0.3 kg mass oscillates, some pendulum motion develops after a few oscillations. If necessary, this can be achieved by clamping the spring to give a slightly shorter length of spring below the clamp. The mass should now be increased to 0.6 kg for candidates to use initially.

If the apparatus is to be used by a second candidate, the 0.6 kg mass should be restored.

Procedure to be followed by candidates

Candidates will be required to investigate the vertical oscillations of masses on a spring. They will time vertical oscillations for a mass of 0.6 kg, and then repeat the procedure for a mass of 0.3 kg.

Some pendulum motion will occur when the 0.3 kg mass is used, and this is to be expected.

Permission to reproduce items where third-party owned material protected by copyright is included has been sought and cleared where possible. Every reasonable effort has been made by the publisher (OCR) to trace copyright holders, but if any items requiring clearance have unwittingly been included, the publisher will be pleased to make amends at the earliest possible opportunity.

OCR is part of the Cambridge Assessment Group. Cambridge Assessment is the brand name of University of Cambridge Local Examinations Syndicate (UCLES), which is itself a department of the University of Cambridge.

A list of candidates, by name and candidate number, requiring help, with details of help provided.

A sample set of results for each experiment is included with this report.

Supervisor's Signature

Date

Centre Number