

**ADVANCED GCE UNIT  
PHYSICS A**

**2826/03/TEST**

Practical Examination 2 (Part B – Practical Test)

**MONDAY 21 MAY 2007**

Afternoon

Time: 1 hour 30 minutes

Additional materials: Candidate's Plan  
(Part A of the Practical Examination)  
Electronic Calculator



Candidate  
Name

Centre  
Number

--	--	--	--	--

Candidate  
Number

--	--	--	--

**INSTRUCTIONS TO CANDIDATES**

- Write your name, Centre Number and Candidate Number in the boxes above.
- Answer **all** the questions.
- Use blue or black ink. Pencil may be used for graphs and diagrams only.
- Read each question carefully and make sure you know what you have to do before starting your answer.
- Do **not** write in the bar code.
- Do **not** write outside the box bordering each page.
- **WRITE YOUR ANSWER TO EACH QUESTION IN THE SPACE PROVIDED. ANSWERS WRITTEN ELSEWHERE WILL NOT BE MARKED.**

**INFORMATION FOR CANDIDATES**

- The number of marks for each question is given in brackets [ ] at the end of each question or part question.
- In the Practical Test you will be assessed on the Experimental and Investigative Skills:  
Skill I Implementing  
Skill A Analysing evidence and drawing conclusions  
Skill E Evaluating evidence and procedures.
- You may use an electronic calculator.
- You are advised to show all the steps in any calculations.
- You will be awarded marks for the quality of written communication where this is indicated in the question.

FOR EXAMINER'S USE		
Qu.	Max.	Mark
<b>Planning</b>	<b>16</b>	
<b>1</b>	<b>28</b>	
<b>2</b>	<b>16</b>	
<b>TOTAL</b>	<b>60</b>	

This document consists of **9** printed pages and **3** blank pages.

**BLANK PAGE**

**PLEASE DO NOT WRITE ON THIS PAGE**

Answer **all** the questions.

**It is recommended that you spend about one hour on question 1.**

**1** In this question you will be investigating the absorption of light as it passes through a number of microscope slides. The light source is a filament bulb connected to a 12V supply, and the detector a photovoltaic (solar) cell.

**(a) (i)** Set up the apparatus as shown in Fig. 1.1. The bulb height has been set for you.

- Position the photocell on the base directly below the bulb.
- Connect the cell to the voltmeter.
- Make a ring of Blu-Tack about 5 mm thick to surround the sensitive area of the photocell. This is to shield the cell from unwanted light and will also act as a non-slip support for the stack of microscope slides.
- Put **two** slides on the ring to check that the slides are horizontal and cover the area of the photocell.

You should take care to keep the microscope slides clean and free from fingerprints as far as possible.

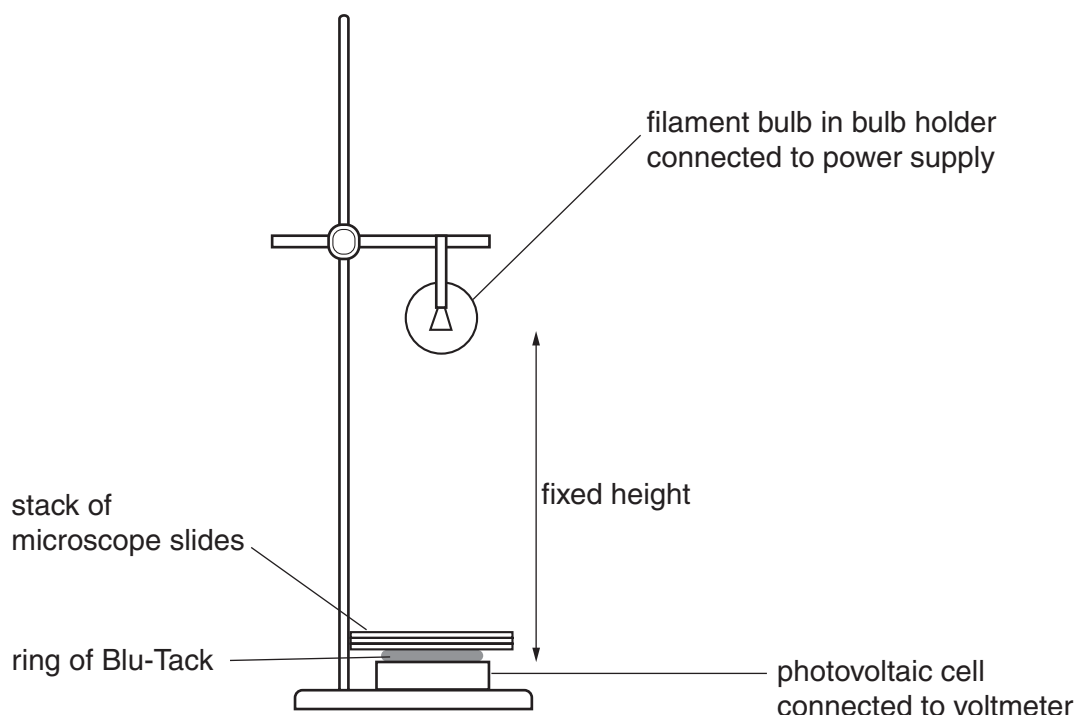

**Fig. 1.1**

**(ii)** Remove the slides. Connect the lamp to the power supply. Record the reading  $V_0$  of the voltmeter in millivolts.

$V_0 = \dots\dots\dots$  mV [1]

- (b) (i) Place **two** of the microscope slides over the photovoltaic cell, and record the voltage  $V$ .

$V = \dots\dots\dots$  mV

- (ii) Change  $n$ , the number of slides over the cell, and record the voltage  $V$  in millivolts for each value of  $n$ . Do this until you have **six** sets of readings in the range  $2 \leq n \leq 20$ . Also record in your table values of  $\ln(V/\text{mV})$ . [7]



- (c) (i) Plot a graph of  $\ln(V/\text{mV})$  ( $y$ -axis) against  $n$  ( $x$ -axis). [4]

- (ii) Draw the line of best fit. Determine the gradient and  $y$ -intercept of this line.

gradient = .....

$y$ -intercept = .....

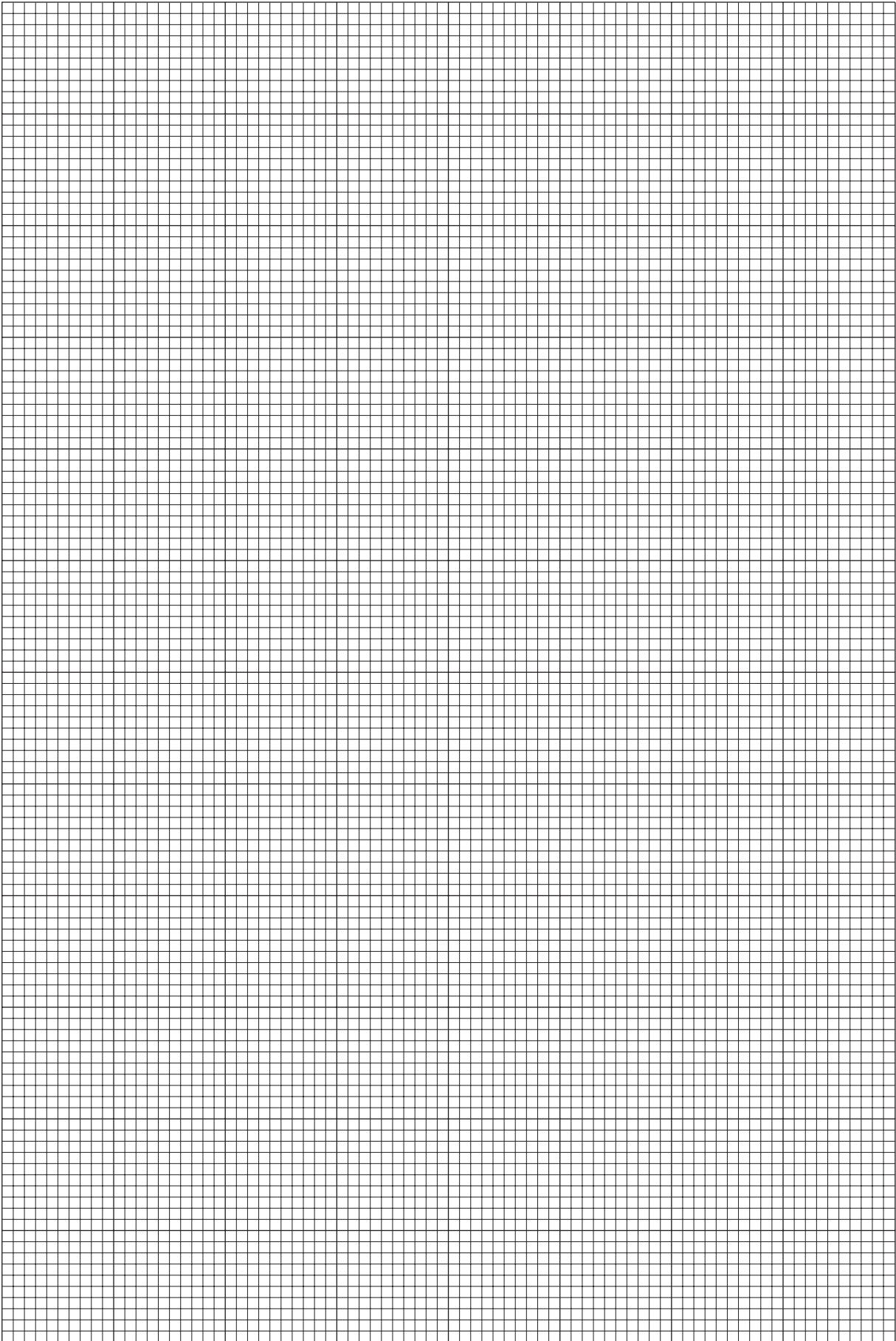
[4]



- (d) Analogy with radioactive absorption suggests that  $V = A e^{-Bn}$ , where  $A$  and  $B$  are unknown constants. Use your answers to (c)(ii) to determine values of  $A$  and  $B$ . You need not be concerned with the units of these quantities.

$$A = \dots\dots\dots$$

$$B = \dots\dots\dots [4]$$

- (e) (i) Use a micrometer screw gauge to measure the thickness  $t$  of one of the microscope slides.

--

$$t = \dots\dots\dots \text{ mm } [2]$$

- (ii) Estimate the percentage uncertainty in this reading.

--

$$\text{percentage uncertainty} = \dots\dots\dots \% [2]$$

- (f) Use your values from (d) and (e)(i) to estimate the thickness of the pile of slides necessary to allow only 50% of the incident light energy to reach the cell. Assume the voltage is directly proportional to the light intensity.

--

$$\text{thickness} = \dots\dots\dots \text{ mm } [3]$$

- (g) Do you think a single piece of glass of this thickness would also reduce the light intensity by 50%? Explain your answer.

--

[1]

[Total: 28]

**7**  
**BLANK PAGE**

**PLEASE DO NOT WRITE ON THIS PAGE**

It is recommended that you spend about 30 minutes on this question.

Approximately half of this time should be spent on the evaluation section in part (d).

2 In this experiment you will investigate the vertical oscillations of a mass on a spring.

The apparatus has been set up for you, with a 0.6 kg mass suspended from the spring.

(a) Displace the 0.6 kg mass vertically by about 4 cm and then release it to perform vertical oscillations.

(i) Make and record measurements in order to determine the period  $T$  of the vertical oscillations.

$T = \dots\dots\dots$ s [2]

(ii) Justify the number of significant figures that you have given for  $T$ .

[1]

(b) Reduce the mass to 0.3 kg. Repeat (a)(i) to give a new value for the period of the vertical oscillations.

$T = \dots\dots\dots$ s [1]

(c) It is suggested that  $T$  is proportional to the square root of  $m$ , the mass on the spring. Do the results of your experiment support this suggestion? Justify your answer.

.....  
 .....  
 .....  
 ..... [2]







11  
BLANK PAGE

PLEASE DO NOT WRITE ON THIS PAGE

**PLEASE DO NOT WRITE ON THIS PAGE**

---

Permission to reproduce items where third-party owned material protected by copyright is included has been sought and cleared where possible. Every reasonable effort has been made by the publisher (OCR) to trace copyright holders, but if any items requiring clearance have unwittingly been included, the publisher will be pleased to make amends at the earliest possible opportunity.

OCR is part of the Cambridge Assessment Group. Cambridge Assessment is the brand name of University of Cambridge Local Examinations Syndicate (UCLES), which is itself a department of the University of Cambridge.