

**ADVANCED GCE UNIT
PHYSICS A**

2826/01

Unifying Concepts in Physics

MONDAY 22 JANUARY 2007

Morning

Time: 1 hour 15 minutes

Additional materials: Electronic calculator
Ruler (cm/mm)



Candidate
Name

Centre
Number

--	--	--	--	--

Candidate
Number

--	--	--	--

INSTRUCTIONS TO CANDIDATES

- Write your name, Centre Number and Candidate number in the boxes above.
- Answer **all** the questions.
- Use blue or black ink. Pencil may be used for graphs and diagrams only.
- Read each question carefully and make sure you know what you have to do before starting your answer.
- Do **not** write in the bar code.
- Do **not** write outside the box bordering each page.
- **WRITE YOUR ANSWER TO EACH QUESTION IN THE SPACE PROVIDED. ANSWERS WRITTEN ELSEWHERE WILL NOT BE MARKED.**

INFORMATION FOR CANDIDATES

- The number of marks is given in brackets [] at the end of each question or part question.
- You may use an electronic calculator.
- You are advised to show all the steps in any calculations.

FOR EXAMINER'S USE		
Qu.	Max	Mark
1	18	
2	13	
3	14	
4	15	
TOTAL	60	

This document consists of **12** printed pages.

Data

speed of light in free space,	$c = 3.00 \times 10^8 \text{ m s}^{-1}$
permeability of free space,	$\mu_0 = 4\pi \times 10^{-7} \text{ H m}^{-1}$
permittivity of free space,	$\epsilon_0 = 8.85 \times 10^{-12} \text{ F m}^{-1}$
elementary charge,	$e = 1.60 \times 10^{-19} \text{ C}$
the Planck constant,	$h = 6.63 \times 10^{-34} \text{ J s}$
unified atomic mass constant,	$u = 1.66 \times 10^{-27} \text{ kg}$
rest mass of electron,	$m_e = 9.11 \times 10^{-31} \text{ kg}$
rest mass of proton,	$m_p = 1.67 \times 10^{-27} \text{ kg}$
molar gas constant,	$R = 8.31 \text{ J K}^{-1} \text{ mol}^{-1}$
the Avogadro constant,	$N_A = 6.02 \times 10^{23} \text{ mol}^{-1}$
gravitational constant,	$G = 6.67 \times 10^{-11} \text{ N m}^2 \text{ kg}^{-2}$
acceleration of free fall,	$g = 9.81 \text{ m s}^{-2}$

Formulae

uniformly accelerated motion,

$$s = ut + \frac{1}{2} at^2$$

$$v^2 = u^2 + 2as$$

refractive index,

$$n = \frac{1}{\sin C}$$

capacitors in series,

$$\frac{1}{C} = \frac{1}{C_1} + \frac{1}{C_2} + \dots$$

capacitors in parallel,

$$C = C_1 + C_2 + \dots$$

capacitor discharge,

$$x = x_0 e^{-t/CR}$$

pressure of an ideal gas,

$$p = \frac{1}{3} \frac{Nm}{V} \langle c^2 \rangle$$

radioactive decay,

$$x = x_0 e^{-\lambda t}$$

$$t_{\frac{1}{2}} = \frac{0.693}{\lambda}$$

critical density of matter in the Universe,

$$\rho_0 = \frac{3H_0^2}{8\pi G}$$

relativity factor,

$$= \sqrt{1 - \frac{v^2}{c^2}}$$

current,

$$I = nAve$$

nuclear radius,

$$r = r_0 A^{1/3}$$

sound intensity level,

$$= 10 \lg \left(\frac{I}{I_0} \right)$$

Answer **all** the questions.

- 1 The web site www.britishwindenergy.co.uk gives the following information for wind turbines.

rotor diameters	30 m – 65 m
useable wind speeds	4 m s^{-1} – 25 m s^{-1}
maximum power output occurs at	15 m s^{-1} wind speed
rate of turning of rotor	15 – 50 revolutions per minute
maximum theoretical efficiency at wind speed 15 m s^{-1}	60%
average power output	30% of theoretical maximum

In this question about wind turbines you will need to use some of this information.

- (a) Consider the mass of the cylinder of air which travels past the blades of a turbine in one second. Take the wind speed to be 15 m s^{-1} and the diameter of the rotor to be 40 m. See Fig. 1.1.

The density of air is 1.3 kg m^{-3} .

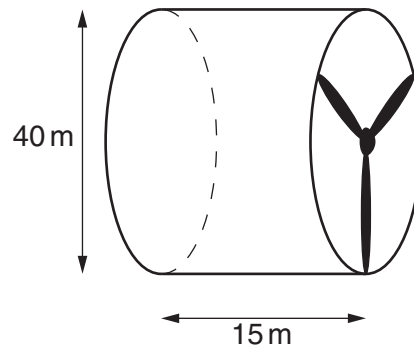

Fig. 1.1

Calculate

- (i) the volume of the cylinder of air passing the rotor in one second

volume = m^3 [2]

- (ii) the mass of air passing the rotor in one second

mass = kg [1]

(iii) the kinetic energy of this mass of air

kinetic energy = J [2]

(iv) the maximum theoretical power output.

power = W [2]

(b) (i) Calculate the average power output from the wind turbine in (a).

average power output = W [1]

(ii) How many of these turbines would be required to replace one 1000MW conventional power station?

number = [1]

(c) (i) Wind power is often said to be free. Give another reason why wind power is desirable.

.....
..... [1]

(ii) Explain why wind power cannot be relied upon.

.....
.....
.....
..... [2]

(d) Suggest reasons why

(i) maximum useable wind speed does not produce maximum power

.....
.....
.....
..... [2]

(ii) turbines have to be stopped when the wind speed is too high

.....
.....
.....
..... [1]

(iii) government policy is to aim for only 10% of national electrical supply to be provided by wind power.

.....
.....
.....
.....
..... [3]

[Total: 18]

- 2 (a) A rechargeable battery is put on charge for 4.0 hours with a constant current of 50 mA from a 6.0 V supply. Calculate

- (i) the charge which flows through the battery in this time

charge = C [3]

- (ii) the energy which has been provided from the supply.

energy = J [2]

- (b) In what form does a battery store energy?

..... energy [1]

- (c) The charged battery has an e.m.f of 4.5 V and is connected to a $48\ \Omega$ resistor. The potential difference across the resistor is found to be 4.0 V. The current is constant during the 45 minutes the battery discharges. Calculate

- (i) the internal resistance of the battery when in use

internal resistance = Ω [2]

- (ii) the energy supplied to the $48\ \Omega$ resistor in this time

energy = J [3]

- (iii) the fraction of the initial energy in (a)(ii) which the energy in (c)(ii) represents.

fraction = [1]

- (d) Explain why the value of the internal resistance calculated in (c)(i) is only reliable to 1 significant figure.

..... [1]

[Total: 13]

[Turn over

3 This question gives some statements which can lead to misconceptions in physics. Each statement is correct.

(a) Friction is sometimes described as a force which prevents motion.

How is it that a forward frictional force on tyres is essential to give a car a forward acceleration?

.....
.....
.....
.....
.....
.....
.....
.....
.....
.....

[3]

(b) Newton's third law states that for every force which body A exerts on body B there is an equal and opposite force which body B exerts on body A.

How can anything ever accelerate?

.....
.....
.....
.....
.....
.....
.....
.....
.....
.....

[3]

- (c) A standing wave set up in air in a pipe is often illustrated by a diagram such as Fig. 3.1.

How can this be possible as sound is a longitudinal wave?

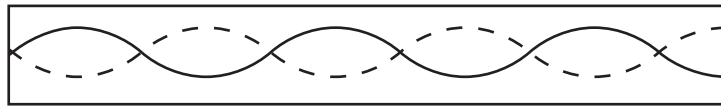

Fig. 3.1

.....

.....

.....

.....

..... [2]

- (d) A battery of e.m.f. E and internal resistance r gives zero output power when on open circuit or when its terminals are shorted together.

Why is this?

.....

.....

.....

..... [2]

- (e) When an astronaut is in the International Space Station, the gravitational force acting on him is 90% of the force acting on him when he is on the Earth's surface.

Why does the astronaut imagine himself to be weightless?

.....

.....

.....

.....

.....

.....

..... [4]

[Total: 14]

[Turn over

- 4 All electromagnetic radiation, as its name implies, has an electric field and a magnetic field. These fields are always at right angles to one another and oscillate in the transmitted wave. The waves at one instant are represented in Fig. 4.1, which is drawn full size.

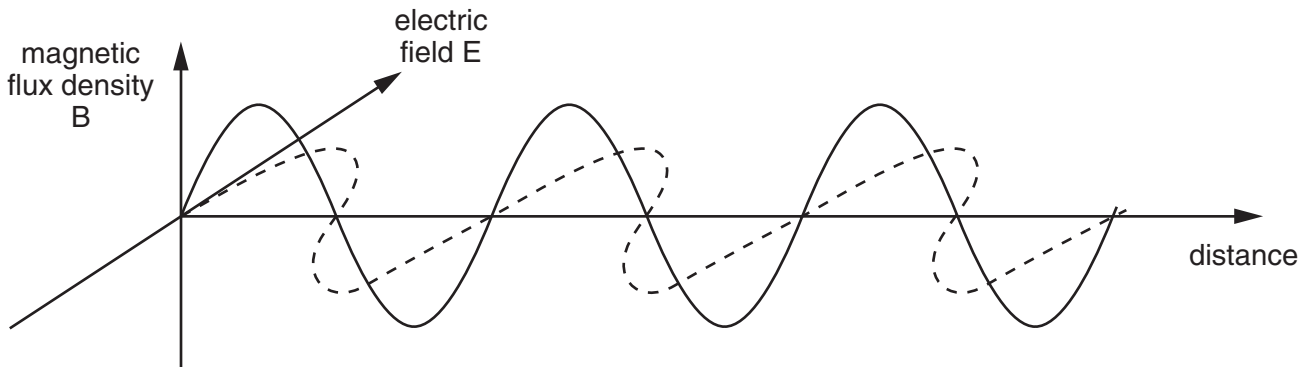

Fig. 4.1

- (a) What is the speed of travel of electromagnetic waves in a vacuum?

speed = ms^{-1} [1]

- (b) (i) Measure the wavelength of the electromagnetic wave in Fig. 4.1.

wavelength = m [1]

- (ii) Calculate the frequency of this wave and give its unit.

frequency = unit [2]

- (iii) What type of electromagnetic wave does this wavelength correspond to in the electromagnetic spectrum?

type of electromagnetic wave [1]

- (c) Waves of this type are used in radar systems where they are passed along tubes called waveguides. One part of the system can be a double tube as shown in Fig. 4.2, where the lengths of the wave paths in the tube are 18 cm and 31 cm as shown. The wavelength of the radar waves in the waveguide is 4.0 cm.

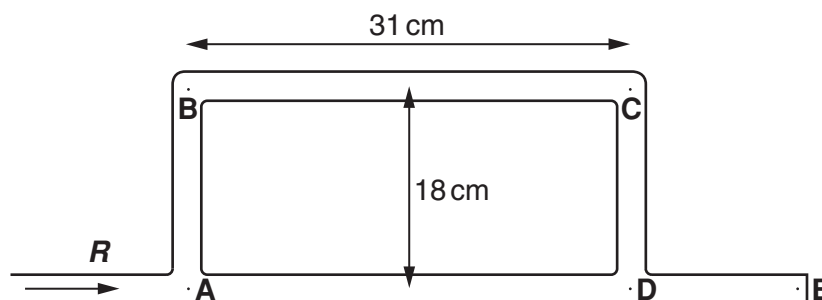

Fig. 4.2

- (i) A wave **R** arriving at **A** can divide at **A** and reach **C** either by path **ABC** or path **ADC**. What is the length of each of these paths?

path length **ABC** = cm

path length **ADC** = cm [1]

- (ii) State the phase difference between the two waves arriving at **C** and comment on the amplitude of the resultant wave.

.....

 [2]

THIS QUESTION CONTINUES ON THE NEXT PAGE.

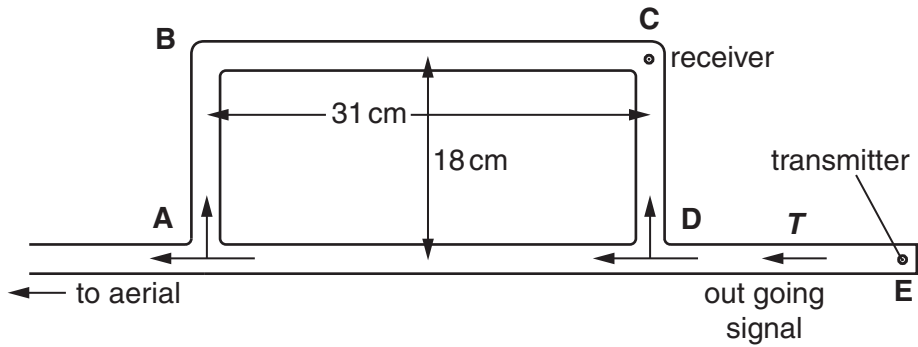

Fig. 4.3

- (iii) Another wave T travelling from E in the opposite direction is shown in Fig. 4.3. It reaches C by paths $DABC$ or DC .

What is the path length of each of these paths?

path length DC = cm

path length $DABC$ = cm [1]

- (iv) Calculate the phase difference between these two waves arriving at C and comment on the amplitude of the resultant wave at C .

.....

 [3]

- (v) In practice in a radar system a powerful transmitter is placed at E while a receiver of weak incoming signals is placed at C . Suggest why this arrangement of waveguides is necessary.

.....

 [3]

[Total: 15]

END OF QUESTION PAPER

Copyright Acknowledgements:

Q.1 data sourced from British Wind Energy Association, www.bwea.com

Permission to reproduce items where third-party owned material protected by copyright is included has been sought and cleared where possible. Every reasonable effort has been made by the publisher (OCR) to trace copyright holders, but if any items requiring clearance have unwittingly been included, the publisher will be pleased to make amends at the earliest possible opportunity.

OCR is part of the Cambridge Assessment Group. Cambridge Assessment is the brand name of University of Cambridge Local Examinations Syndicate (UCLES), which is itself a department of the University of Cambridge.