

1. No mark scheme available

2. The list gives some quantities and units. *Underline* those which are base quantities of the International (SI) System of units.

coulomb    force    length    mole    newton    temperature interval

(2 marks)

Define the volt.

**Volt = Joule/Coulomb or Watt/Ampere**

(2 marks)

Use your definition to express the volt in terms of base units.

**Volt = J/C**

**= kg m<sup>2</sup> s<sup>-2</sup>/A s**

**= kg m<sup>2</sup> s<sup>-3</sup> A<sup>-1</sup>**

(3 marks)

Explain the difference between scalar and vector quantities

**Vector has magnitude and direction**

**Scalar has magnitude only**

(2 marks)

Is potential difference a scalar or vector quantity?

**Scalar**

(1 mark)

[Total 10 marks]

3. A cell of negligible internal resistance is connected in series with a microammeter of negligible resistance and two resistors of 10 kΩ and 15 kΩ. The current is 200 μA.

Draw a circuit diagram of the arrangement

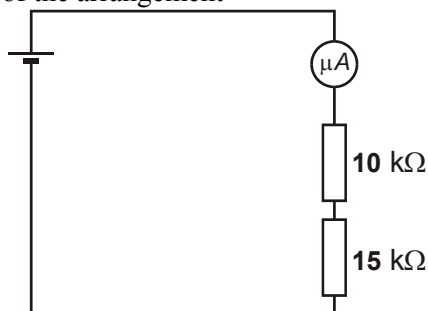

(1 mark)

Calculate the e.m.f. of the cell.

**e.m.f. = (200 μA) × (2.5 kΩ)**

**= 5000 m(A Ω)**

**e.m.f. = 5.0 V**

(2 marks)

Where a voltmeter is connected in parallel with the 15 kΩ resistor, the current in the microammeter increases to 250 μA. Sketch a diagram of the modified circuit.

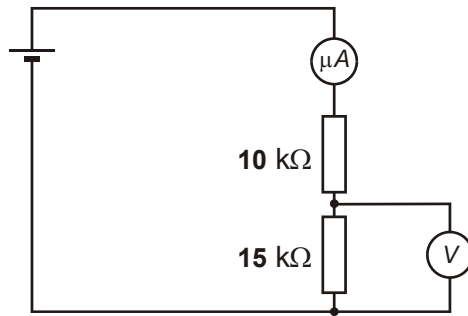

(1 mark)

Calculate the resistance of the voltmeter.

**Series Resistance = 5.0 V / 250 μA = 20 kΩ**

$$\frac{1}{R_v} + \frac{1}{15000} + \frac{1}{10000}$$

**Resistance =  $R_v = 30 \text{ k}\Omega$**

(3 marks)

[Total 7 marks]

4. A copper wire is 2.0 m long and has a cross-sectional area of 1.00 mm<sup>2</sup>. It has a p.d. of 0.12 V across it when the current in it is 3.5A. Draw a circuit diagram to show how you would check these voltage and current values.

**Circuit showing**

**Variable power supply (or fixed but with variable resistor) (1)**

**Ammeter in series with labelled wire (1)**

**Voltmeter in parallel with wire (1)**

(3 marks)

Calculate the rate at which the power supply does work on the wire.

**Rate of working or  $IV = (0.12 \text{ V}) \times (3.5 \text{ A})$  (1)**

**Rate = 0.42 W (1)**

(2 marks)

Copper has about  $1.7 \times 10^{29}$  electrons per metre cubed. Calculate the drift speed of the charge carriers in the wire.

**Using equation  $I = nAqv$  (1)**

**Substitution in  $v = I/nAq$  (1)**

**$v = (3.5 \text{ A}) / (1.7 \times 10^{29} \text{ m}^{-3}) (1 \times 10^{-6} \text{ m}^2) (1.6 \times 10^{-19} \text{ C})$**

**Drift speed =  $1.29 \times 10^{-4} \text{ m s}^{-1}$  (1)**

(3 marks)

The power from the supply connected to the wire is equal to the total force  $F_t$  on the electrons multiplied by the drift speed at which the electrons travel. Calculate  $F_t$

$$\text{Power} = F_t \times v$$

$$\text{Substitution in } F_t = \text{power} / v$$

$$= (0.42 \text{ W}) / (1.29 \times 10^{-4} \text{ m s}^{-1})$$

$$F_t = 3.3 \text{ kN}$$

(3 marks)

[Total 11 marks]

5. A light-dependent resistor may be used with additional components to make a light meter. Sketch a diagram for a suitable circuit.

**Examples**

*Examples*

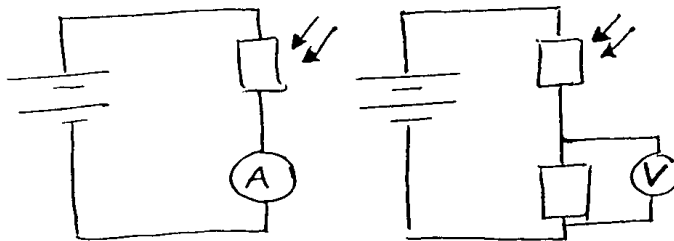

(-1) for each error in the diagram. Correct working circuit (2)

(2 marks)

Explain how your circuit works

$R_L$  decreases with increasing incident light intensity (1)

Whence increase in A or V reading (1)

(2 marks)

[Total 4 marks]

6. A 24 W filament lamp has been switched on for some time. In this situation the first law of thermodynamics, represented by the equation  $\Delta U = \Delta Q + \Delta W$ , may be applied to the lamp. State and explain the value of each of the terms in the equation during a period of two seconds of the lamp's operation.

$$\Delta U = 0 \quad (1)$$

because filament temperature is constant (1)

(2 marks)

$$\Delta W = 48 \text{ J} \quad (1)$$

work done on the filament by power supply (1)

(2 marks)

$$\Delta Q = 48 \text{ J} \quad (1)$$

energy given to (allow 'lost from') filament by heating (1)

(2 marks)

Typically, filament lamps have an efficiency of only a few percent. Explain what this means and how it is consistent with the law of conservation of energy.

**Small proportion out as light (1)**

**the rest of the energy heats the surroundings (1)**

**(2 marks)**  
**[Total 8 marks]**

7. (a) (i)  $P = \frac{mgh}{t}$  (Allow  $P = Fv$ )  $54.9 \text{ N} \times 2.31 \times 10^{-6} \text{ m s}^{-1}$  (1)

$$= \frac{5.6 \text{ kg} \times 9.8 \text{ N kg}^{-1} \times 1.4 \text{ m}}{7 \times 24 \times 3600 \text{ s}} \quad (1)$$

$$= 1.3 \times 10^{-4} \text{ W} \quad (1)$$

If only  $mgh$  calculated (77 J), max (1)

**(3 marks)**

(i) Use of  $mc\Delta\theta$

A valid expression for  $\theta$   
or answer  $0.038 \text{ }^\circ\text{C/K}$  ( $0.039$  if  $10$  used) (1)

Assumption: all g.p.e. becomes internal energy/  
all heat in the cylinder / no heat loss / no air friction (1)

**(3 marks)**

(b) (i) Mention of Earth's magnetic field (1)

[Look for back credit from part (c)]  
Pendulum cuts this field/flux (1)

So e.m.f./p.d. is induced (not current) (1)

**(3 marks)**

(ii)

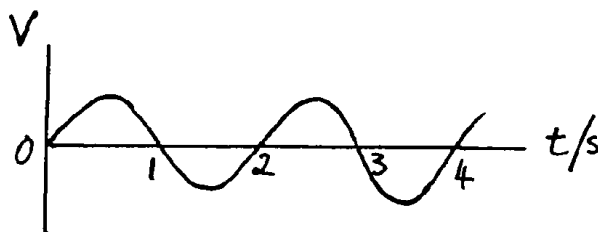

Any repetitive graph (1)

Sinusoidal in shape (1)

Time scale correct (i.e. period 2 s) (1)

**(3 marks)**

- (c) **Statement that energy conservation is violated/  
perpetual motion machines are impossible/  
drawing power would damp oscillation (2)**  
(Allow not practicable to connect to bottom of pendulum for 1 mark only)  
**Discussion: induced p.d./e.m.f. could produce a current (1)**  
**which would dissipate/use energy (1)**  
**Switches could attract steel at correct part of swing (1)**

(Max 4 marks)  
[Total 16 marks]

8. With the aid of an example, explain the statement “The magnitude of a physical quantity is written as the product of a number and a unit”.

**Both number and unit identified in an example (1)**

**followed by the idea of multiplication (1)**

(2 marks)

Explain why an equation must be homogeneous with respect to the units if it is to be correct.

**If the units on one side differ from those on the other, then the two sides of the equation relate to different kinds of physical quantity. They cannot be equal [or similar positive statements] (1)**

(1 mark)

Write down an equation which is homogeneous, but still incorrect.

**Any incorrect but homogeneous algebraic or word equation :  
2mgh = ½mv<sup>2</sup>, 2 kg = 3 kg, pressure = stress/strain (2 or 0)**

(2 marks)

[Total 5 marks]

9. Define the term *resistivity*.

$$\text{Either } \rho = \frac{RA}{l} \text{ or } R = \frac{\rho l}{A} \quad (1)$$

**with symbols defined (1)**

(2 marks)

The resistivity of copper is  $1.7 \times 10^{-8} \Omega \text{ m}$ . A copper wire is 0.6 m long and has a cross-sectional area of  $1 \text{ mm}^2$ . Calculate its resistance.

$$\text{Resistance} = (1.7 \times 10^{-8} \Omega \text{ m}) \quad (1) \quad \frac{(0.6 \text{ m})}{1 \times 10^{-6} \text{ m}^2} \quad (1)$$

$$\text{Resistance} = 10.2 \text{ m}\Omega \quad (1)$$

(3 marks)

Two such wires as used to connect a lamp to a power supply of negligible internal resistance.

The potential difference across the lamp is 12 V and its power is 36 W. Calculate the potential difference across each wire.

$$\text{Current} = 36 \text{ W}/12 \text{ V} = 3 \text{ (A)} \quad (1)$$

$$\text{P.d} = (3 \text{ A}) \times (10.2 \times 10^{-3} \Omega) \quad (1)$$

$$\text{Potential difference} = 30.6 \text{ mV} \quad (1)$$

(3 marks)

Draw a circuit diagram of the above arrangement. Label the potential differences across the wires, lamp and power supply.

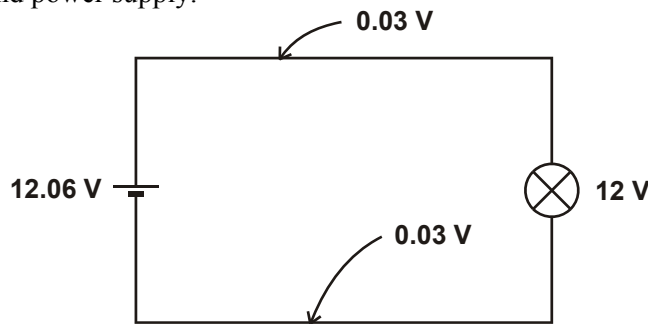

lamp (1)

both wires (1)

cell (1)

(Allow 12 V cell and 11.94 V across lamp)

(3 marks)  
[Total 11 marks]

10. The power supplies in the two circuits shown below are identical.

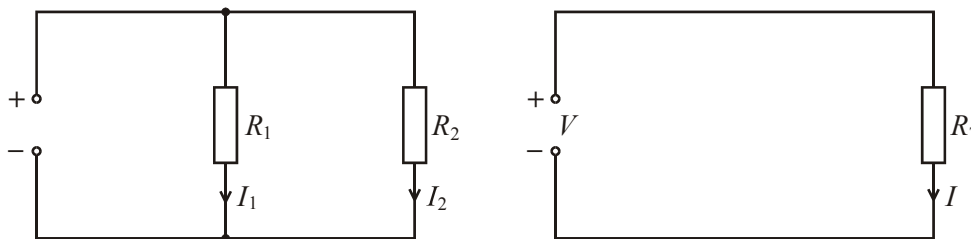

Write down the relationship between  $I_1$ ,  $I_2$  and  $I$  which must hold if the combined resistance of the parallel pair,  $R_1$ , and  $R_2$ , is to equal  $R_T$ .

$$I = I_1 + I_2$$

(1 mark)

Hence derive the formula for the equivalent resistance of two resistors connected in parallel.

From Ohm's law:

$$I = V/R_T \quad I_1 = V/R_1 \quad I_2 = V/R_2 \quad (1)$$

$$\therefore V/R_T = V/R_1 + V/R_2 \quad (1)$$

$$\text{and } 1/R_T = 1/R_1 + 1/R_2 \quad (1)$$

(3 marks)

Use your formula to show that the resistance between the terminals of a low-resistance component is hardly changed when a high-resistance voltmeter is connected in parallel with it.

$$\text{If } R_v \gg R_{\text{low}} \text{ then } 1/R_v \gg 1/R_{\text{low}} \quad (1)$$

$$\text{and } R_T \approx R_{\text{low}} \quad (1)$$

Allow method based on numerical example

(2 marks)  
[Total 6 marks]

11. A student pours 500 g of water into an aluminium saucepan of mass 1.20 kg, heats it over a steady flame and records the temperature as it heats up. The temperatures are plotted as shown below.

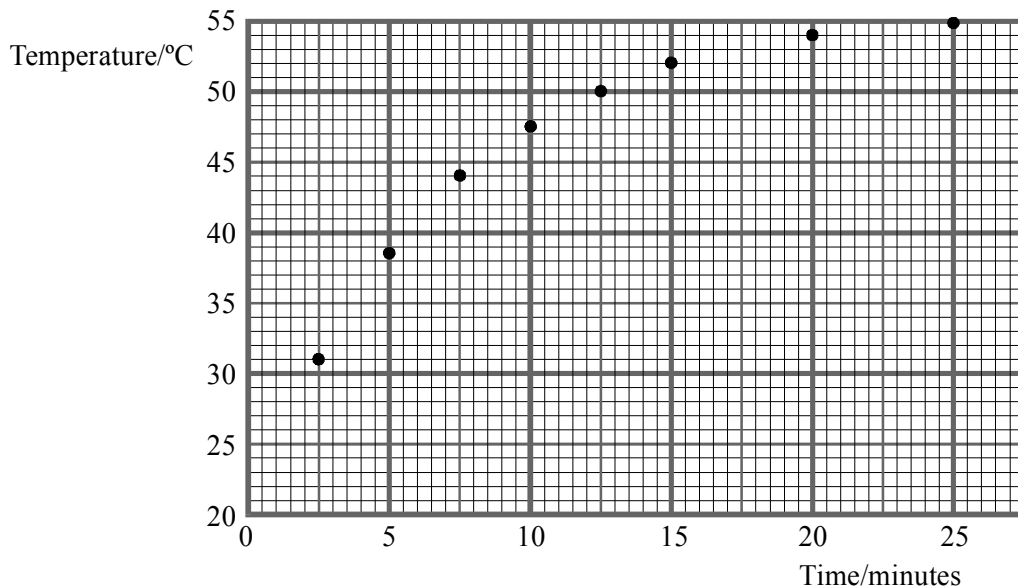

Calculate the total heat capacity of the saucepan and water.

$$\text{Specific heat capacity of water} = 4200 \text{ J kg}^{-1} \text{ K}^{-1}$$

$$\text{Specific heat capacity of aluminium} = 900 \text{ J kg}^{-1} \text{ K}^{-1}$$

$$\text{Heat capacity} = (0.500 \text{ kg} \times 4200 \text{ J kg}^{-1} \text{ K}^{-1}) + (1.20 \text{ kg} \times 900 \text{ J kg}^{-1} \text{ K}^{-1}) \quad (1) + (1)$$

$$\text{Heat capacity} = 3180 \text{ J K}^{-1} \quad (1)$$

(3 marks)

Find the rate of rise of water temperature at the beginning of the heating process.

$$\text{Rate of rise of water temperature} = \frac{(11 \text{ K})}{(150 \text{ s})} \quad (1)$$

$$\text{Rate of rise of temperature} = 0.073 \text{ K s}^{-1} \quad (1)$$

(2 marks)

Hence find the rate at which energy is supplied to the saucepan and water.

$$\text{Rate of energy supply} = (3180 \text{ J K}^{-1}) \times (0.073 \text{ K s}^{-1}) \quad (1)$$

$$\text{Rate of energy supply} = 0.23 \text{ kW} \quad (1)$$

(2 marks)

Explain why the rate at which the temperature rise slows down progressively as the heating process continues.

As the temperature of the saucepan increases (1)

an increasing fraction of the heat supplied per second goes to the surroundings (1)

(2 marks)

[Total 9 marks]

12. The relationship  $pV = \text{constant}$  applies to a sample of gases provided that two other physical variables are constant. Name them.

First variable      **Mass (or equivalent)**      (1)

Second variable    **Temperature (or equivalent)**      (1)

(2 marks)

With the aid of a diagram, describe carefully how you would test the relationship by experiment.

**If either pressure or volume can be adjusted only by allowing the mass of the gas or its temperature to change, then 0/6**

**Apparatus showing fixed mass of gas**      (1)

**volume scale**      (1)

**pressure gauge**      (1)

**Record values of pressure and volume**      (1)

**at several different pressures**      (1)

**and look to see if a graph of  $p$  against  $1/V$  is a straight line**      (1)

(6 marks)

[Total 8 marks]

13. (a) Explain how the distance from an observer to a lightning flash may be estimated. Illustrate this for the case where the distance is 1.5 km.

**Light travels very fast/instantaneously/at  $3 \times 10^8$  m/s**      (1)

**To travel 1.5 km, sound takes 4.4 s**      (1)

**Measuring time enables distance to be found**      (1)

(3 marks)

- (b) Explain the meaning of the phrase *sheet lightning* (paragraph 2).

Use the passage to explain how thunder is produced.

**Sheet lightning: flash/ stroke/discharge**      (1)

**within a cloud/from cloud to cloud**      (1)

**Thunder: air heated**      (1)

**rapid expansion**      (1)

**shock wave**      (1)

(5 marks)



- (c) The diagram represents a storm cloud over a building with a high clock tower.

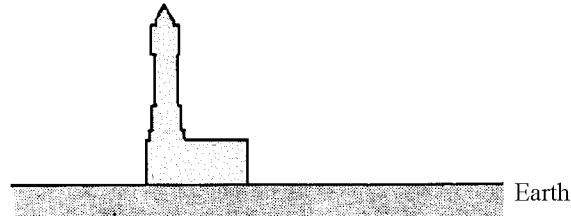

Copy the diagram. Explain, with the aid of additions to your diagram, what is meant by a *negative leader* (paragraph 3).

- Charge -ve on cloud (1)**
- Charge + ve on tower (1)**
- Jagged line from cloud to tower (1)**
- Negative leader is column of charged ions (1)**
- Negative leader marked on diagram (1)**

**(Max 4 marks)**

- (d) Describe the process by which a lightning stroke produces visible light.

Explain why, when you see a lightning flash, it may seem to flicker.

- Electrical discharge in air (1)**
- ionises/excites electrons/molecules (1)**
- which emit light/photons (1)**
- When they return to ground state (1)**
- Flicker: a whole series of/several strokes (1)**
- in a short time/rapidly (1)**

**(Max 5 marks)**

- (e) Suppose lightning strikes from a cloud to the Earth along a channel 400 m long.

Calculate

- (i) a typical potential difference between cloud and Earth,  
**Either Or**

$$P = 4 \times 10^{10} \text{ W} \quad P = IV \Rightarrow \frac{P}{l} = I \frac{V}{l} \quad (1)$$

$$P = IV \rightarrow V = P/I \quad E = \frac{V}{l} = \frac{P/l}{I} \quad (1)$$

$$\Rightarrow V = 2 \times 10^6 \text{ V} \quad = 5000 \text{ V m}^{-1} \quad (1)$$

**(3 marks)**

- (ii) the average electric field strength along such a lightning channel.

$$E = \frac{V}{d} \quad E = VI \quad (1)$$

$$= 5000 \text{ V m}^{-1} \quad = 2 \times 10^6 \text{ V} \quad 2$$

**(3 marks)**

- (f) Describe how you would attempt to demonstrate in the laboratory that the electric field strength needed to produce a spark in air is about  $3000 \text{ V mm}^{-1}$  ( $3 \times 10^6 \text{ V m}^{-1}$ ). Suggest why this value differs from that which you calculated in (e).

**e.h.t./Van der Graaf (1)**

**with voltmeter (1)**

**Two metal terminals/spheres/plates (1)**

**Comment on atmospheric conditions (1)**

**(4 marks)**

- (g) Estimate the pressure of the air within a lightning channel immediately after a lightning flash. Take the atmospheric pressure to be 100 kPa. State any assumptions you make.

**Air temperature, any value in kelvin (1)**

$$\frac{p}{T} = \text{constant} \quad (1)$$

**Assume V constant (1)**

$$\Rightarrow p = \text{around } 10\,000 \text{ kPa} \quad (2)$$

**(5 marks)**

**[Total 32 marks]**

14. (a) Describe briefly how you would determine a value for the *specific heat capacity*  $c$  of water using normal laboratory apparatus.

**Electrical method**

**Method of mixtures**

**Electrical heater**

**Know temperature of hot body (1)**

**Water in container with thermometer**

**Water in container with thermometer (1)**

**$I V t$  or  $P t$  or joulemeter**

**Heat capacity of apparatus (1)**

**$mc\Delta\theta$**

**$mc\Delta\theta$  (1)**

**Precaution: low C container/insulation/lid/stir (1)**

**(Max 4 marks)**

- (b) A jogger of mass 75 kg, who runs for 30 minutes, generates 840 kJ of thermal energy.

- (i) Explain, in molecular terms, the way in which the removal of some of this energy by evaporation can help to prevent the jogger's body temperature from rising.

**Fast energetic molecules escape/evaporate (1)**

**Remaining ones have less kinetic energy/when bonds broken (1)**

**Reference to latent heat from jogger (1)**

**(3 marks)**

If 40% of the thermal energy is removed by evaporation, calculate the mass of water evaporating during the 30 minute jog. Take the specific latent heat (enthalpy) of vaporisation of water to be  $2260 \text{ kJ kg}^{-1}$  and the density of water to be  $1000 \text{ kg m}^{-3}$

$$40\% \text{ of } 840 \text{ kJ} = 336 \times 10^3 \text{ J} \quad (1)$$

$$H = ml \Rightarrow m = H/l \quad (1)$$

$$\Rightarrow m = 0.15 \text{ kg}/150 \text{ g} \quad (1)$$

**(3 marks)**

- (c) During a single stride the *horizontal push*  $F$  of the ground on the jogger's foot varies with time  $t$  approximately as shown in the graph.  $F$  is taken to be positive when it is in the direction of the jogger's motion.

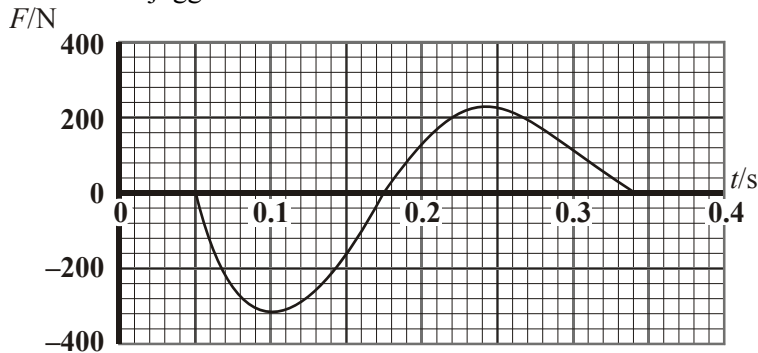

- (i) What physical quantity is represented by the area between the graph line and the time axis?

**Impulse/change of momentum (1)**

Estimate the size of this quantity for the part of the graph for which  $F$  is positive.  
Explain how you made your estimate.

**Area: counting squares or  $F_{av} \times t$  or use of triangles (1)**

**$\geq 15 \leq 25$  (1)**

**$\text{N s/kg m s}^{-1}$  (1)**

**(4 marks)**

- (ii) The area above the time axis is the same as the area below it. Explain what this tells you about the motion of the jogger.

**Net impulse/change of momentum zero (1)**

**so jogger has constant speed/velocity (1)**

**(2 marks)**

**[Total 16 marks]**

15. An  $\alpha$ -source with an activity of 150 kBq is placed in a metal can as shown. A 100 V d.c. source and a  $10^9 \Omega$  resistor are connected in series with the can and the source. This arrangement is sometimes called an ionisation chamber.

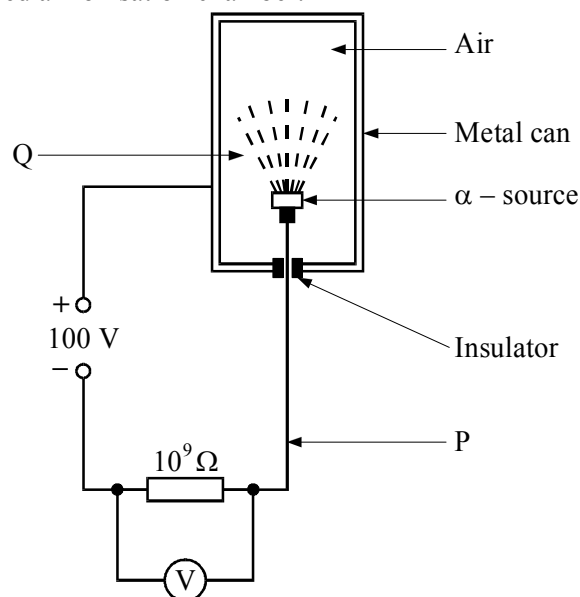

- (a) What is meant in this case by *an activity of 150 kBq*?  
 **$150 \times 10^3$  particles/decays/disintegrations (1)**  
**per second (1)**

(2 marks)

- (b) Describe how the nature of the electric current in the wire at P differs from that in the air at Q.

**At P: negatively charged/delocalised (1)**  
**electrons (1)**

**At Q: ions (1)**

(3 marks)

- (c) A potential difference of 3.4 V is registered on the voltmeter.

- (i) Calculate the current in the wire at P. State any assumption you make.

$$I = \frac{V}{R} \quad (1)$$

$$\Rightarrow I = 3.4 \times 10^{-9} \text{ A} \quad (1)$$

**Assume resistance of voltmeter greater than  $10^9 \Omega$ /very big or no/very little current voltmeter (1)**

- (ii) Calculate the corresponding number of ionisations occurring in the metal can every second. State any assumption you make.

**Assume ions singly charged/there is no recombination (1)**

**Use of  $1.6 \times 10^{-19} \text{ C}$  (1)**

$$\Rightarrow N = \frac{3.4 \times 10^{-9} \text{ C}}{1.6 \times 10^{-19} \text{ C}} \quad (1)$$

(Max 5 marks)

- (d) With the  $\alpha$ -source removed from the metal can, the voltmeter still registers a potential difference of 0.2 V. Suggest two reasons why the current is not zero.

**Insulator not perfect (1)**

**Voltmeter has zero error (1)**

**Background radiation (1)**

(2 marks)

- (e) The half-life of the  $\alpha$ -source is known to be 1600 years. Calculate the decay constant and hence deduce the number of radioactive atoms in the source.

$$\lambda t_{1/2} = \ln 2 \quad (1)$$

$$\Rightarrow \lambda = 1.37 \times 10^{-11} \text{ s}^{-1} \text{ or } 4.33 \times 10^{-4} \text{ y}^{-1} \quad (1)$$

$$\Rightarrow N = 1.1 \times 10^{16} \quad (1)$$

(4 marks)

[Total 16 marks]

16. The circuit shows a battery of negligible internal resistance connected to three resistors.

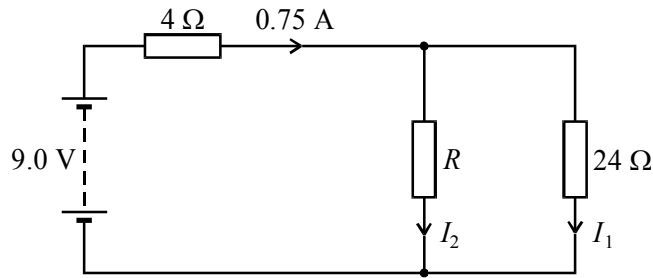

Calculate current  $I_1$ .

$$\text{Voltage drop across } 4\Omega \text{ resistor} = 3\text{V} \quad (1)$$

$$I_2 = \frac{(9\text{ V} - 3\text{ V})}{24\ \Omega} \quad (1)$$

$$I_1 = 0.25\text{ A} \quad (1)$$

(3 marks)

Calculate resistance  $R$

$$I_2 = 0.75\text{ A} - 0.25\text{ A} = 0.50\text{ A} \quad (1)$$

$$R = 6\text{ V} / 0.50\text{ A} = 12\ \Omega \quad (1)$$

$$R = 12\ \Omega$$

(2 marks)

[Total 5 marks]

17. The circuit shown is used to produce a current voltage graph for a 12 V, 24 W lamp.

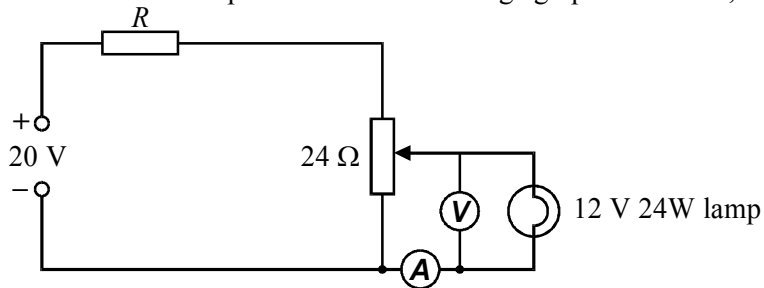

Show on the diagram the correct position for a voltmeter and an ammeter.

(2 marks)

Calculate the resistance of the lamp in normal operation.

$$\text{Current } I = \text{power} / \text{voltage} = \frac{24\text{ W}}{12\text{ V}} = 2\text{ A} \quad (1)$$

$$\text{Resistance} = \frac{\text{voltage}}{\text{current}} = \frac{12\text{ V}}{2\text{ A}} \quad (1)$$

$$\text{Resistance} = 6\ \Omega \quad (1)$$

(3 marks)

Calculate the value for  $R$  which would enable the voltage across the lamp to be varied between 0 V and 12V.

**6  $\Omega$  and 24  $\Omega$  form a parallel pair (1)**

**of resistance 4.8  $\Omega$  (1)**

**Drawing current of 2.5 A (1)**

**$R = 8 \text{ V} / 2.5 \text{ A}$**

**$R = 3.2 \Omega$**

**(4 marks)**  
**[Total 9 marks]**

18. The circuit shown is used to charge a capacitor.

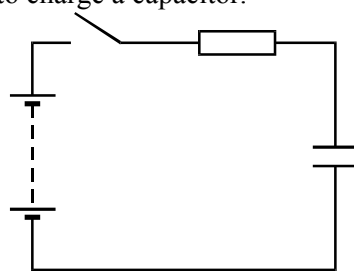

The graph shows the charge stored on the capacitor whilst it is being charged.

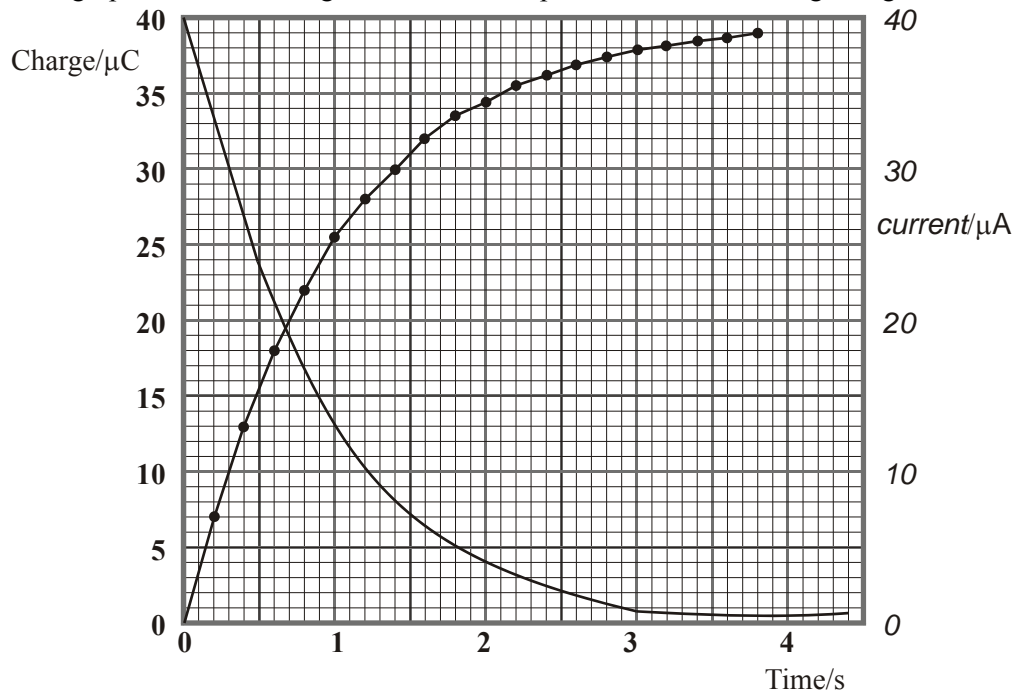

On the same axes, sketch as accurately as you can a graph of current against time. Label the current axis with an appropriate scale.

**Label current axis (1)**

**Current at  $t = 0$  within range 30 – 45  $\mu\text{A}$  (1)**

**Current graph right shape (1)**

**Exponential decay (1)**

**(4 marks)**

The power supply is 3 V. Calculate the resistance of the charging circuit.

$$\begin{aligned} \text{Resistance} &= 3 \text{ V} / 40 \text{ } \mu\text{A} & (1) \\ &= 75 \text{ k}\Omega & (1) \end{aligned}$$

$$\text{Resistance} = \text{Allow } 66 \text{ k}\Omega \rightarrow 100 \text{ k}\Omega$$

(2 marks)  
[Total 6 marks]

19. A mass is oscillating vertically on the end of a spring. Explain what happens to the following quantities as the mass rises from the bottom of its motion to the top.

Kinetic energy

**Increases from zero at bottom to maximum at midpoint (1)  
and falls back to zero at the top (1)**

**[1 only for increases and then decreases]**

Gravitational potential energy

**Increases as the height increases (1)**

Elastic potential energy

**Decreases from maximum position at bottom (1)**

**(ignore reference to possible eventual increase)**

(4 marks)

After a long time, the mass stops oscillating. What has happened to the energy?

**Transformed (by friction) into heat (1)  
in the spring or in the surroundings (1)**

(2 marks)  
[Total 6 marks]

20. What is meant by a *heat engine*?

**A device which takes heat/energy from a hot source (1)  
converts a fraction of this energy into useful work (1)  
and transmits the rest to a cold sink (1)**

**[Allow 1 for conversion of heat to work]**

(3 marks)

Explain why there is a constant search for materials to make turbine blades that will operate at higher temperatures to improve the efficiency of thermal power stations.

$$\text{Reference to efficiency} = \frac{T_1 - T_2}{T_1} \quad (1)$$

**A higher working temperature gives a higher working efficiency (1)**

(2 marks)  
[Total 5 marks]

21. The permittivity of free space  $\epsilon_0$  has units  $F m^{-1}$ . The permeability of free space  $\mu_0$  has units  $N A^{-2}$

Show that the units of  $\frac{1}{\sqrt{\epsilon_0 \mu_0}}$  are  $m s^{-1}$

Any two:

$$N = kg m s^{-2}$$

$$F = C/V$$

$$V = J/C$$

$$Q = A s \quad (1) \quad (1)$$

Unambiguous manipulation to correct answer (1)

(3 marks)

Calculate the magnitude of  $\frac{1}{\sqrt{\epsilon_0 \mu_0}}$ .

$$\sqrt{\frac{1}{8.85 \times 10^{-12} F m^{-1} \times 4\pi \times 10^{-7} N A^{-2}}}$$

$$\text{Magnitude} = 3.0 \times 10^8 \quad (1)$$

(1 mark)

Comment on your answers.

**This is the speed of light (1)**

(1 mark)

[Total 5 marks]

22. For each of the four concepts listed in the left hand column, place a tick by the correct example of that concept in the appropriate box.

A base quantity	mole	<input type="checkbox"/>	length	<input checked="" type="checkbox"/>	kilogram	<input type="checkbox"/>
A base unit	coulomb	<input type="checkbox"/>	ampere	<input checked="" type="checkbox"/>	volt	<input type="checkbox"/>
A scalar quantity	torque	<input type="checkbox"/>	velocity	<input type="checkbox"/>	kinetic energy	<input checked="" type="checkbox"/>
A vector quantity	mass	<input type="checkbox"/>	weight	<input checked="" type="checkbox"/>	density	<input type="checkbox"/>

[Total 4 marks]

23. You are asked to measure the specific heat capacity of aluminium using a cylindrical block of aluminium which has been drilled out to accept an electrical heater.

Draw a complete diagram of the apparatus you would use.

**Diagram showing**

**heater in aluminium block with suitably-placed thermometer, (1)**

**lagging round the surface of the block and (1)**

**a circuit-diagram with correctly-placed voltmeter, ammeter and power supply (1)**

(3 marks)



Describe how you would carry out the experiment and list the measurements you would take.

**Measure and record the mass of the block ( $m$ ) (1)  
and the initial temperature ( $\theta_1$ ) (1)**

**Switch on the current and start the clock at the same time.**

**Record voltmeter and ammeter readings ( $I$  and  $V$ ). (1)**

**Stop clock after an appreciable rise in temperature. Note time ( $t$ ). (1)**

**Note final temperature of block ( $\theta_2$ ) (1)**

**(5 marks)**

Explain how you would calculate the specific heat capacity of aluminium from your measurements.

**Energy transferred to block =  $IVt$  (1)**

**Increase in internal energy of block =  $m c (\theta_2 - \theta_1)$  (1)**

**Specific heat capacity of aluminium  $c = \frac{IVt}{m(\theta_2 - \theta_1)}$  (1)**

**(3 marks)**

**[Total 11 marks]**

24. Describe the concept of the heat engine.

**A mechanism in which**

**heat from a higher temperature source (1)**

**flows in part to a lower temperature sink (1)**

**while the remainder is converted into useful work (1)**

**(3 marks)**

Define the term “efficiency” used in connection with heat engines.

**Efficiency =  $\frac{\text{Heat transformed into work}}{\text{Heat flowing from source}}$  1**

1

**(2 marks)**

**[Total 5 marks]**

25. One simple model of the hydrogen molecule assumes that it is composed of two oscillating hydrogen atoms joined by two springs as shown in the diagram.

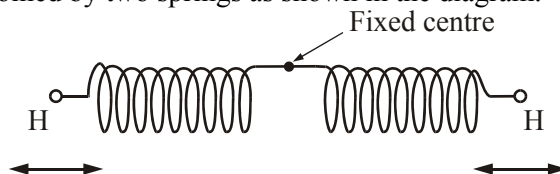

If the spring constant of each spring is  $1.13 \times 10^3 \text{ N m}^{-1}$  and the mass of a hydrogen atom is  $1.67 \times 10^{-27} \text{ kg}$ , show that the frequency of oscillation of a hydrogen atom is  $1.31 \times 10^{14} \text{ Hz}$ .

$$T = 2\pi \sqrt{\frac{m}{k}} = 2\pi \sqrt{\frac{1.67 \times 10^{-27} \text{ kg}}{1.13 \times 10^3 \text{ N m}^{-1}}} = 7.6 \times 10^{-15} \text{ s} \quad (1)$$

$$f = \frac{1}{T} = \frac{1}{7.6 \times 10^{-15} \text{ s}} = 1.31 \times 10^{14} \text{ Hz} \quad (1)$$

**(2 marks)**

Using this spring model, discuss why light of wavelength  $2.29 \times 10^{-6} \text{ m}$  would be strongly absorbed by the hydrogen molecule.

$$c = f \lambda \quad (1)$$

$$f = \frac{3.00 \times 10^8 \text{ ms}^{-1}}{2.29 \times 10^{-6} \text{ m}} = 1.31 \times 10^{14} \text{ Hz} \quad (1)$$

This frequency is the same as the hydrogen atom frequency in the model (1)

hence resonance occurs and strong absorption. (1)

(4 marks)

[Total 6 marks]

26. You are given a piece of resistance wire. It is between two and three metres long and has a resistance of about  $15\Omega$ . You are asked to measure the resistivity of the metal alloy it is made from.

Make the necessary additions to the following circuit to enable it to be used for the experiment.

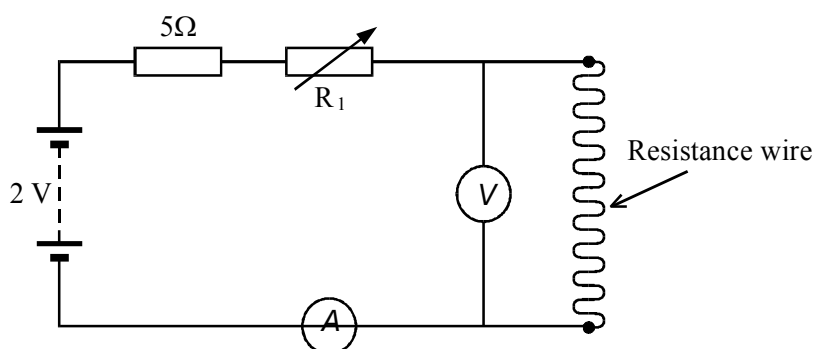

(2 marks)

Describe briefly how you would use the circuit above to measure the resistance of the wire.

**Record values of V and I (1)**

**for different values of V (1)**

**by changing  $R_1$  (1)**

**Draw a graph of V against I (1)**

**Resistance = gradient (1)**

(5 marks)

Once the resistance of the wire is known, two more quantities must be measured before its resistivity can be calculated. What are they?

**Length (1)**

**Diameter (1)**

(2 marks)

Is there any advantage in finding the resistance of the wire from a graph compared with calculating an average value from the measurements? Explain your answer.

**Allow any good reason for an implied 'yes' (z/o) (1)**

**Be ready to give full credit for an implied 'no' (1)**

(2 marks)

[Total 11 marks]

27. Classify each of the terms in the left-hand column by placing a tick in the relevant box.

[Total 6 marks]

28. The circuit diagram shows a 12 V power supply connected across a potential divider R by the sliding contact P. The potential divider is linked to a resistance wire XY through an ammeter. A voltmeter is connected across the wire XY.

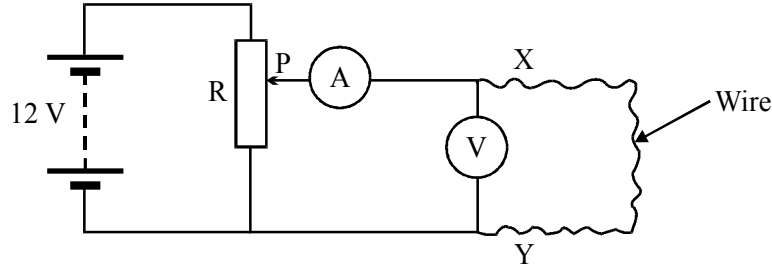

Explain, with reference to this circuit, the term *potential divider*.

**The fraction of the battery voltage which is set across the wire. (1)**

**Can be varied between 0 V and 12 V by moving the slider P. (1)**

(2 marks)

The circuit has been set up to measure the resistance of the wire XY. A set of voltage and current measurements is recorded and used to draw the following graph.

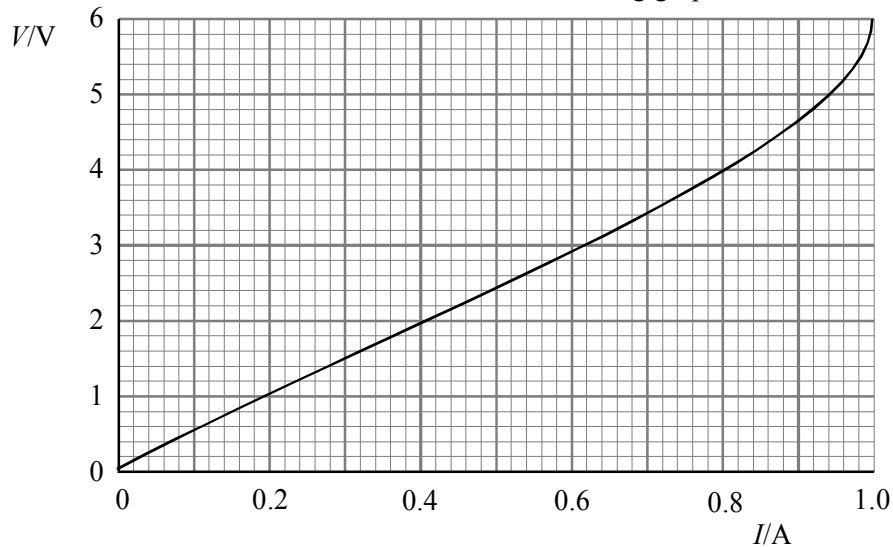

Explain why the curve deviates from a straight line at higher current values.

**The wire gets hot (1)**

**and the resistance increases. (1)**

(2 marks)

Calculate the resistance of the wire for low current values.

**$R = (3.4 \text{ V}) / (0.7 \text{ A})$  or equivalent (1)**

**Resistance of wire =  $4.9 (\pm 0.3) \Omega$  (1)**

(2 marks)

To determine the resistivity of the material of the wire, two more quantities would have to be measured. What are they?

**length (1)**

**cross-sectional area / diameter (1)**

**(2 marks)**

Explain which of these two measurements you would expect to have the greater influence on the error in a calculated value for the resistivity? How would you minimise this error?

**area or diameter (1)**

**Any two from**

**Diameter is small or uneven (1)**

**Use micrometer screw gauge (1)**

**To measure the diameter at several places (1)**

**Error in area is double error in diameter (1)**

**(3 marks)**

**[Total 11 marks]**

**29. (a) Either**

$$E = hc/\lambda$$

**(1)**

$$\lambda = (6.6 \times 10^{-34} \text{ J s}) (3.0 \times 10^8 \text{ m s}^{-1}) \div (10^{-23} \text{ J})$$

**(1)**

$$\approx 2 \times 10^{-2} \text{ m}$$

**(1)**

**Or**

$$E = hf$$

**(1)**

$$f = (10^{-23} \text{ J}) \div (6.6 \times 10^{-34} \text{ J s})$$

**(1)**

$$f = 1.5 \times 10^{10} \text{ Hz}$$

**(1)**

Therefore P is microwave/radar/long infra-red

**(1)**

Q is infra-red and R is visible

**(1)**

**(Max 4 marks)**

(b) Experiment:

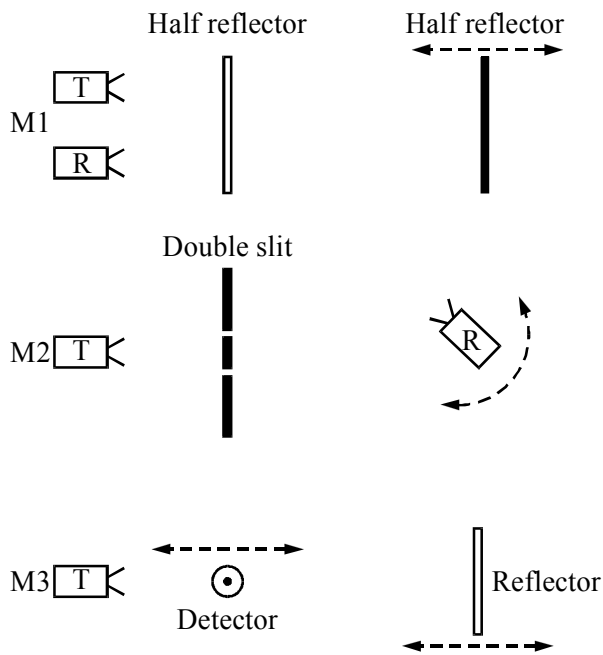

Diagram OR description

labelled OR full description applicable

to 20 mm electromagnetic waves

What moves/is done

How  $\lambda$  is found:

e.g. M1 reflect moves  $\lambda/2$  between max/min

e.g. M2  $S_1P - S_2P = \lambda$  at first max

e.g. M3  $\lambda/2$  between nodes

(1)

(1)

(1)

(1)

(1)

(1)

(5 marks)

(c) (i) **Either**

$$\frac{R_D}{2200 \Omega} = \frac{1.2 \text{ V}}{4.8 \text{ V}}$$

$$\therefore R_D = 1.2 \text{ V} \div 0.0022 \text{ A}$$

$$R_D = 550 \Omega$$

Assumption  $R_V \gg 550 \Omega$

**Or**

$$I = \frac{6.0 \text{ V} - 1.2 \text{ V}}{2200 \Omega} = 0.0022 \text{ A}$$

$$= 545 \Omega$$

(2)

(1)

(1)

(4 marks)

(ii) **Either**

Put a microammeter/  
sensitive ammeter in  
the circuit/in series

$$I \approx 1 \mu\text{A} \quad R_D \approx 1 \text{ M}\Omega$$

**Or**

Replace 2,2 k $\Omega$  with bigger  $R$

of known value

Repeat calculation

(1)

(1)

(1)

(3 marks)

[Total 16 marks]

30. (a) Experiment:
- Heat rapped gas fully immersed in water bath (1)
  - Thermometer labelled (1)
  - Pressure gauge/manometer labelled (1)
  - Precautions:
  - Stir before measuring/await thermal equilibrium (1)
  - Short/thin link to pressure measurer/parallax with Hg (1)
- (5 marks)
- (b) Units:
- Use of Pa as  $\text{N m}^{-2}$  (1)
  - Use of J as  $\text{N m}$  (1)
- (2 marks)
- Calculation:
- $p \propto T / pV \div T = \text{constant} / pV = nRT$  (1)
  - Therefore  $T = 640 \text{ K} \times (2800 \text{ kPa} \div 900 \text{ kPa})$  (1)
  - $= 1990 \text{ K} / 2000 \text{ K}$  (1)
  - Assumption:
  - Mass gas/number moles/amount of gas constant (1)
- (4 marks)
- (c)  $a = (2\pi f)^2 x / \omega^2 x$  (1)
- $a_{\text{max}} = (2\pi \times \frac{8000}{60} \text{ s}^{-1})^2 (0.040 \text{ m})$  (1)
  - $= 28000 \text{ m s}^{-2}$  (1)
- (3 marks)
- Explanation:
- High stress in rod/rod needs to have high strength (1)
  - Both tensile and compressive (1)
- (2 marks)  
[Total 16 marks]

31. A wire 6.00 m long has a resistivity of  $1.72 \times 10^{-8} \Omega \text{ m}$  and a cross-sectional area of  $0.25 \text{ mm}^2$ . Calculate the resistance of the wire.

$$R = \rho l / A \quad (1)$$

$$= \frac{(1.72 \times 10^{-8} \Omega \text{ m})(6.00 \text{ m})}{(0.25 \times 10^{-6} \text{ m}^2)} \quad (1)$$

Resistance = **0.41 A** (1)

The wire is made from copper. Copper has  $1.10 \times 10^{29}$  free electrons per metre cubed. Calculate the current through the wire when the drift speed of the electrons is  $0.093^{-1} \text{ mm s}^{-1}$ .

$$I = n A q v \quad (1)$$

$$= (1.10 \times 10^{29} \text{ m}^{-3})(0.25 \times 10^{-6} \text{ m}^2) \times (1.60 \times 10^{-19} \text{ C})(0.093 \times 10^{-3} \text{ ms}^{-1}) \quad (1)$$

Current = **0.41 A** (1)

The wire is cut in two and used to connect a lamp to a power supply. It takes 9 hours for an electron to travel from the power supply to the lamp. Explain why the lamp comes on almost as soon as the power supply is connected.

**Electrons behave like an incompressible fluid (2)**  
**Current flow is immediate throughout circuit (1)**  
**(Allow equivalent explanations)**

[Total 9 marks]

32. A container holding 2.3 litres of milk at  $15^\circ \text{C}$  is put into a freezer. Calculate the energy that must be removed from the milk to reduce its temperature to the freezer temperature of  $-30^\circ \text{C}$ .

Assume that the milk behaves like ice and water.

Specific heat capacity of water = 4.2 kJ kg<sup>-1</sup> K<sup>-1</sup>

Specific heat capacity of ice 2.1 kJ kg<sup>-1</sup> K<sup>-1</sup>

Specific latent heat (enthalpy) of fusion of ice = 330 kJ kg<sup>-1</sup>

Density of water = 1.0 kg litre<sup>-1</sup>

$$E = mc_1 \Delta \theta_1 + mL + mc_2 \Delta \theta_2 \quad (1)$$

$$m = 2.3 \text{ kg}$$

$$(2.3\text{kg}) (4200 \text{ Jkg}^{-1} \text{ K}^{-1}) (15\text{K}) \text{ or } 145 \text{ kJ} \quad (1)$$

$$(2.3\text{kg}) (330,000 \text{ Jkg}^{-1}) \text{ or } 759 \text{ kJ} \quad (1)$$

$$(2.3\text{kg}) (2100 \text{ Jkg}^{-1} \text{ K}^{-1}) (30\text{K}) \text{ or } 145 \text{ kJ} \quad (1)$$

$$\text{Energy removed} = \dots 1.05 \text{ MJ} \quad (1)$$

(6 marks)

It costs 8.2 p per kWh to remove energy from the freezer. What is the cost of freezing the milk?

$$\frac{(8.2 \text{ p/kW hr})}{1000 \times 3600 \text{ J/kW hr}} \times (1.05 \times 10^6 \text{ J}) \quad (1)$$

$$\text{Cost} = 2.4\text{p} \quad (1)..$$

(2 marks)

[Total 8 marks]

33. The kinetic theory of gases is based on a number of assumptions. One assumption is that the average distance between the molecules is much larger than the molecular diameter. A second assumption is that the molecules are in continuous random motion. State and explain one observation in support of each assumption.

First assumption

**Either large volume change on change of state (1)**

**implies large spacing of gas molecules (1).**

**[OR faster diffusion through gases (1)**

**implies more spacing for molecular motion (1)]**

(or equivalent)-

Second assumption

**Brownian motion in gases (1)**

**Smoke particles subject to random knock about from air molecules (1)**

**(or equivalent)**

[Total 4 marks]

34. (a) Upward/electrical force equals/balances weight (1)  
 $EQ = mg$  (1)  
 $E = \frac{V}{d} = \frac{500\text{V}}{5.8 \times 10^{-3}\text{m}}$  (1)  
 $= 8.62 \times 10^4 \frac{\text{V}}{\text{m}} / \frac{\text{N}}{\text{C}}$   
 $= mg = (1.4 \times 10^{-14}\text{kg}) (9.8 \text{ N kg}^{-1})$  (1)  
 $= 1.37 \times 10^{-13}\text{N}$   
 $\Rightarrow Q = \frac{1.37 \times 10^{-13}\text{N}}{8.62 \times 10^4 \text{NC}^{-1}} = 1.59 \times 10^{-18} \text{C}$  (1)  
Horizontal: so that two forces/ $EQ$  and  $mg$  are parallel (1) 6
- (b)  $\beta$  source emits electrons (1)  
which ionise air (molecules) (1)  
Positive ions are attracted to sphere (1)  
Free-body diagram showing upward drag/resistive force (1) Max 3
- (c) Quantised: charge comes in lumps/discrete amounts/packets (1)  
Other: energy/electro-magnetic wave (energy)/light (1)  
Situation: photoelectric effect/spectra/energy levels (1)  
Description of how the situation chosen shows quantisation (1) 4
- (d) Spheres are being hit/bombarded (1)  
by air molecules/particles (1)  
which are in random motion (1)  
[Max 1 for simply Brownian motion]  
Lower temperature: air molecules' speed/kinetic energy is reduced (1) Max 3
35. (a) (i) Energy (per s) = NeV (1)  
(ii) Use of  $E = Pt$  (1)  
 $\Rightarrow E = (2.4 \text{ W}) (20 \text{ s}) = 48 \text{ J}$  (1)  
Use of  $\Delta Q = mc\Delta t$  (1)  
 $\Rightarrow m = 0.77 \times 10^{-3} \text{ kg}$  (1)  
Assume:  
All energy transferred to heat/no energy transferred to light (1)  
No heat conducted away from spot/only spot heated (1) 7



(b) Either

Direct electrical method:

Measure  $Ivt$  (1)

Measure  $m\Delta\theta$  for suitable lump of glass (1)

Sketch/description of apparatus (1)

Or

Method of mixtures:

Measure temperature of hot glass (1)

Measure  $m_w c_w \Delta_w$  and measure  $m_g \Delta\theta_g$  (1)

Sketch/description of apparatus (1)

Difficulty:

Glass poor conductor linked to experiment (1)

Difficult to prevent heat loss linked to experiment (1)

5

36. Resistance calculation:

*Either*

$$R = V^2/W = (230 \text{ V})^2 / (100 \text{ W}) \quad (1)$$

$$= 529 \Omega \quad (1)$$

*Or*

$$I = W/V = 100 \text{ W}/230 \text{ V} = 0.43 \text{ A} \quad (1)$$

$$R = V/I = 230 \text{ V}/0.43 \text{ A} = 529 \Omega \quad (1)$$

2

Reason and Explanation:

Reference to  $I = nAqv$  (1)

Reduced area of filament (1)

Current same at all points in circuit (1)

Assume  $n$  is not significantly different (1)

Hence low  $A$  implies high  $v$  (1)

Max 4

[Total 6 marks]

37. Joule:  $\text{kg m}^2 \text{s}^{-2}$  (1)

Coulomb: Derived unit (1)

Time: Scalar quantity (1)

Volt:  $\text{W} \times \text{A}^{-1}$  (1)

[Total 4 marks]

38. Definition of resistivity:

$$\text{Resistivity} = \frac{\text{Resistance} \times \text{area}}{\text{length}} \quad (2)$$

2

[Give full credit for a correct statement about a 1-meter cube]

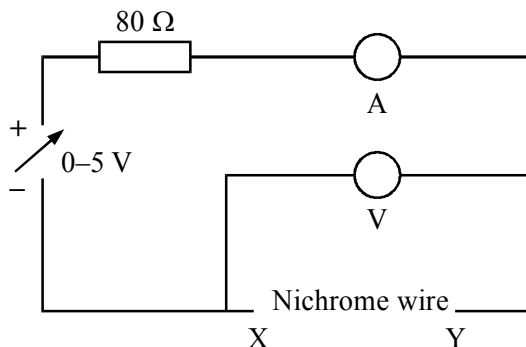

Ammeter in correct position (1)

Voltmeter in correct position (1)

2

Explanation:

A high current heats the wire (1)

and changes the resistivity (1)

[Allow (1) "to protect ammeter" or similar]

2

Resistance of nichrome wire:

Resistance =  $V/I$  (or gradient) (1)

=  $(0.12 \text{ V}) / (0.050 \text{ A})$  (1)

=  $2.4 \Omega$  (1)

3

Resistivity of nichrome:

Area =  $\pi r^2 = 2.73 \times 10^{-7} \text{ m}^2$  (1)

Resistivity =  $\frac{(2.4 \Omega)(2.73 \times 10^{-7} \text{ m}^2)}{(0.51 \text{ m})}$  (1)

$1.29 \times 10^{-6} \Omega \text{ m}$  (1)

3

[No unit penalty]

[Total 12 marks]

39. Energy given out =  $mc\Delta\theta$  (1)

=  $(1.2 \times 1000 \text{ kg})(4200 \text{ J kg}^{-1} \text{ K}^{-1})(98 \text{ }^\circ\text{C} - 65 \text{ }^\circ\text{C})$  (1)

Energy = 166 MJ (1)

3

Time =  $\frac{\text{Energy}}{\text{Power}} = \frac{W}{P}$  (1)

=  $\frac{1.66 \times 10^8 \text{ J}}{6 \times (1.5 \times 10^3 \text{ W})}$  (1)

Time = 18 400 s/307 min/5.1 h (1)

3

[Do not penalise modest rounding differences]

Any two of the following:

Temperature difference greater in morning than evening (1)

Clear reasons (1)

$\therefore$  greater output in morning than evening (1)

2

[Total 8 marks]

40. Completion of a correct circuit diagram:

Ammeter in series with lamp and supply [Ignore voltmeter position]

Voltmeter across lamp and ammeter [and maybe with ammeter]

2

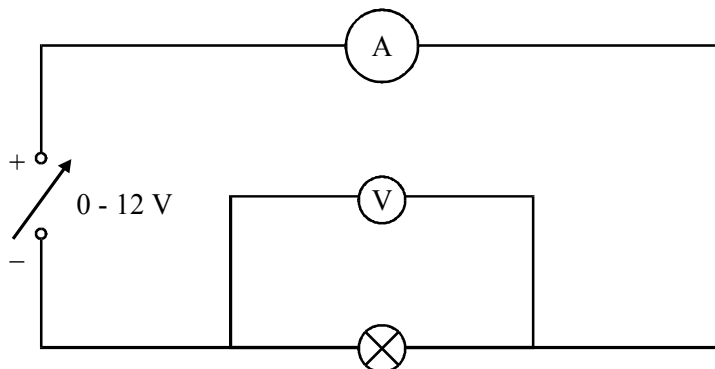

Measurements:

Record voltmeter reading

Record corresponding ammeter reading [“corresponding” may be implied]

Repeat for range of supply voltage settings [or currents]

3

Labelled sketch:

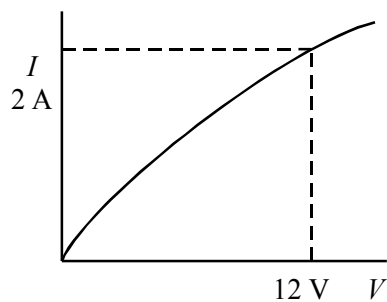

Label axes  $I$  and  $V$  [with or without units]

Graph line with correct curvature [overlook any tendency of the current value to saturate]

Show 12 V, 2 A correctly [Allow 12 and 2 if units are labelled on axes]

3

[The second mark is lost if axes are not labelled, unless 2 A and 12 V are present, with the units, to make sense of the axes.]

[8]

41. Diagram of torch circuit:

The lamp will light

Correct circuit

2

[Circuit showing one cell only is allowed one mark only unless the cell is labelled 4.5 V. If a resistor is included, allow first mark only unless it is clearly labelled in some way as an internal resistance.]

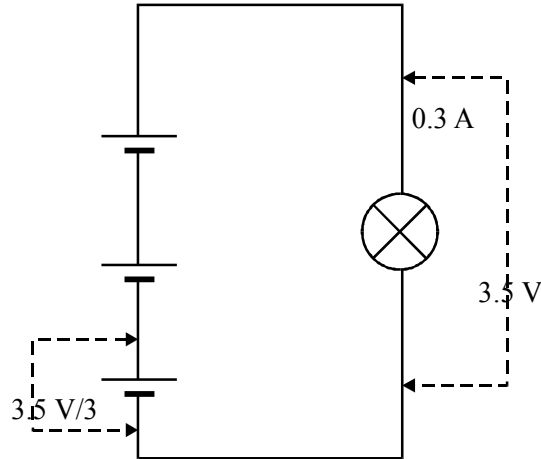

Voltage across each circuit component and current in lamp:

Either 3.5 V/3 shown across the terminals of one cell or 3.5 V across all three cells

3.5 V shown to be across the lamp

0.3 A flowing in the lamp [i.e. an isolated 0.3 A near the lamp does not score]

3

Calculation of internal resistance of one of the cells:

$$\text{Lost volts} = 4.5 \text{ V} - 3.5 \text{ V} \text{ or } 1.5 \text{ V} - \frac{3.5 \text{ V}}{3}$$

$$\text{or total resistance} = (4.5 \text{ V}) / (0.3 \text{ A}) = 15 \text{ K}\Omega$$

$$\text{Internal resistance of one cell} = [(1.0 \text{ V}) / (0.3 \text{ A})] \div 3$$

$$\text{or } [(0.33 \text{ V}) / (0.3 \text{ A})] \text{ or lamp resistance} = (3.5 \text{ V}) / (0.3 \text{ A}) = 11.7 \Omega$$

$$= 1.1 \Omega \text{ or } = (3.3 \Omega) / 3 = 1.1 \Omega$$

3

[Some of these latter marks can be read from the diagram if it is so labelled]

[8]

42. Ohm and farad expressed in terms of SI base units:

$$\text{Ohm: volt/ampere allow V/A but not V/1 or } \Omega \rightarrow \text{V A}^{-1} \rightarrow \text{V C}^{-1} \text{ s}$$

$$= \text{kg m}^2 \text{ A}^{-2} \text{ s}^{-3}$$

$$\text{Farad: coulomb/volt allow C/V but not Q/V or F} \rightarrow \text{C V}^{-1}$$

$$(\text{=} \text{A}^2 \text{ s}^4 \text{ kg}^{-1} \text{ m}^{-2})$$

[Give third mark where they seem to work back correctly from  $\text{kg m}^2 \text{ A}^{-2} \text{ s}^{-3}$ ]

4

Demonstration that ohm  $\times$  farad = second or  $V C^{-1} s \times C V^{-1} \rightarrow s$

[No mark if the second comes from multiplying two incorrect expressions]

Calculation of charge at beginning of 10.0 ms discharge period:

$$(40\,000\ \mu\text{F}) \times (12\ \text{V}) \\ = 0.48\ \text{C}$$

Calculation of charge at end of the 10.0 ms discharge period:

$$(40\,000\ \mu\text{F}) \times (10.5\ \text{V}) = 0.42\ \text{C} \quad 3$$

[Allow the third mark if a wrong answer, e.g. 42 C, comes from repeating the same arithmetical error as was made in the earlier calculation.]

[If a wrong equation is used such as  $Q = 1/2 CV^2$ , the above three marks are lost but the wrong answers can be carried forward into the following current calculation (67.5 A).]

Average current:

$$\frac{(0.48\text{C} - 0.42\text{C})}{10\ \text{ms}}$$

[(1) for correct charge/time, (1) for correct time] 3

$$= 6\ \text{A}$$

Advantage of reduced discharge time: 2

Minimal drop or much reduced drop in voltage value  
Reason - insufficient time for larger voltage drop, or similar

[12]

43. Initial rate of rise of water temperature:

[Allow (1) for attempt to find gradient of graph at origin.]

Rate of temperature rise = temperature rise/corresponding time interval

$$=(0.030 \rightarrow 0.042)\text{K s}^{-1} \text{ [Allow } ^\circ\text{C s}^{-1}] \quad 2$$

[Note: (1.8  $\rightarrow$  K min<sup>-1</sup> gets 1<sup>st</sup> mark but not the 2<sup>nd</sup>)]

Estimate of initial rate of gain of heat from surroundings:

$$\frac{\Delta Q}{\Delta t} = mc \frac{\Delta \theta}{\Delta t} \\ = (0.400\ \text{kg}) (4200\ \text{J kg}^{-1}\ \text{K}^{-1}) (0.033\ \text{K s}^{-1}) \\ = 50 \rightarrow 71\ \text{W} \quad 3$$

[Allow 1<sup>st</sup> and 2<sup>nd</sup> marks if middle line is stated correctly.

Allow J min<sup>-1</sup> if K min<sup>-1</sup> is brought forward. Penalise inconsistent units.]

Explanation of twenty-seven minute delay:

Time needed for heat inflow to melt the ice [2/0] 2

Estimate of mass of ice initially present:

$$\text{Energy absorbed } \Delta Q = \frac{\Delta Q}{\Delta t} t \quad (1) = ml \quad (1)$$

$$m = \frac{(56 \text{ W})(27 \times 60 \text{ s})}{(2.27 \times 10^6 \text{ J})}$$

$$= 0.035 \text{ kg} \rightarrow 0.051 \text{ kg}$$

4

[Allow full credit for correct specific latent heat capacity value (334 kg  $\rightarrow$  0.051 kg<sup>-1</sup>) leading to 0.243 kg  $\rightarrow$  0.344 kg.]

[11]

44. (a) Newton's second law implied  
 Idea of push of CO<sub>2</sub> gases on system  
 Idea of system pushes out gases/Newton's third law  
 Newton's third law implied Max 3
- (b) (i) Conservation of momentum stated  
 $(0.012 \text{ kg})v = (0.68 \text{ kg})(2.7 \text{ m s}^{-1}) / (0.668 \text{ kg})(2.7 \text{ m s}^{-1})$   
 $\rightarrow v = 153 \text{ m s}^{-1} / 150 \text{ m s}^{-1}$   
 Assume all CO<sub>2</sub> small/no drag 4
- (ii) Kinetic energy CO<sub>2</sub> =  $\frac{1}{2} (0.012 \text{ kg}) (153 \text{ m/s})^2 / (150 \text{ m/s})^2$   
 $= 140 \text{ J} / 135 \text{ J}$   
 Kinetic energy trolley =  $\frac{1}{2} (0.68 \text{ kg})(2.7 \text{ m/s})^2 / \frac{1}{2} (0.668 \text{ kg})(2.7 \text{ m/s})^2$   
 $= 2.5 \text{ J} / 2.4 \text{ J}$  3
- (c) (i) energy is needed to evaporate CO<sub>2</sub> go gaseous/latent heat  
 and this energy is taken from the system
- (ii) Use a thermocouple/thermistor  
 Difficulty: time delay in registering/thermal contact
- (iii) Measure mass of cylinder  
 Look up s.h.c. of cylinder (material) 6

[16]

45. (a) Sound is longitudinal  
 Vibrations in one direction only  
 Air is made to vibrate/oscillate
- Units:  
 $p$  as  $\text{N m}^{-2}$  and  $\rho$  as  $\text{kg m}^{-3}$   
 the  $N$  as  $\text{kg m s}^{-1}$   
 Algebra to show  $\text{LHS} = \text{RHS} = \text{m s}^{-1}$  6

- (b) (i) Resistance down  
Current up/ $V_m + V_R = \text{constant}$   
Hence p.d. across R up Max 2
- (ii) Frequency:  
5 cycles in 8 cm/1 cycle in 1.6 cm.,  
 $\therefore T = (1.6 \text{ cm})(250 \mu \text{ cm}^{-1}) = 400 \mu \text{s}$   
so  $= \frac{1}{T} = \frac{1}{400 \times 10^{-6} \text{s}} = 2500 \text{ Hz}$   
Amplitude:  
Amplitude 1.0/1.05 cm  
Multiplied by  $0.2 \text{ mV cm}^{-1} \rightarrow 0.20/0.21 \text{ mV}$  5
- (iii) *Either*  
Two dippers  
Driven up and down  
Project water surface  
Or  
Microwave transmitter  
Source and double slit  
Move detector across 3

**[16]**

46. What is meant by “an equation is homogeneous with respect to its units”:  
Each side/term has the same units 1
- Equation  $x = ut + \frac{1}{2} at^2$ :  
 $ut - (\text{m s}^{-1}) \text{s} = \text{m}$   
 $at^2/2 (\text{m s}^{-2}) \text{s}^2 = \text{m}$   
all 3 terms reduce to m 3  
[Allow dimensions]
- Explanation:  
Wrong numerical constant/wrong variables  
Units same, numbers wrong/  
Units same, magnitudes wrong 1

Example =  $1 \text{ kg} + 2 \text{ kg} = 5 \text{ kg}$

**[5]**

47. (a) Mark the method *before* marking the circuit

Suitable circuit				Short circuit option 
What is measured	Set of readings of $V$ and $I$	$V$ and $I$	Two sets of $V$ and $I$	$V$ and $I$
What is then done	Plot $V$ against $I$	Record $V$ for open circuit	Substitute in $V = E - Ir$	Record $V$ for open circuit
Finding $E$ and $r$	$E =$ intercept $r = -$ gradient	$E =$ open circuit voltage $r$ from $V = E - Ir$	Solve simultaneous equations	$E =$ open circuit voltage $r$ from $r = E - Ir$

Suitable circuit			Potentiometer 	
What is measured	$V$ for known $R$	$I$ for known $R$	Two sets of $I$ and $R$	$l$ for known $R$
What is then done	Record $V$ for open circuit	Record $V$ for open circuit	Substitute in $E = I(R + r)$	$l'$ for open circuit
Finding $E$ and $r$	$E =$ open circuit voltage $r$ from $E/V = (R + r)/R$	$E =$ open circuit voltage $r$ from $E = I(R + r)$	Solve simultaneous equations	$E$ from $l'$ (calibrated) $\frac{l'}{l} = \frac{(R + r)}{R}$

Mark other procedures in a similar way

4



[Mark text, then tick for circuit if it does the job described.

If diagram *alone*, ask if it can do the job and give mark if yes]

(b) (i) p.d. across battery:

$$V = E - Ir$$

$$= 12.0 \text{ V} - 3.0 \text{ A} \times 3.0 \Omega \text{ (substitution)}$$

$$= 3.0 \text{ V}$$

2

(ii) Straight line from (0,12) to (3,3) (e.c.f.)

1

Current: 2.05 to 2.10 A

1

[8]

[Allow correct intersection of their line (ignore shape),  $\pm 0.05 \text{ A}$ , of the characteristic with their graph, even if theirs is wrong. A line MUST be drawn for the last mark.]

48. Explanation of variation shown on the graph:

More electrons set free. Any one from: as temperature increases; thermal energy/vibration increases/  
resistance decreases/current increases

2

Resistance of thermistor:

$$V \text{ (across thermistor)} = 1.20 \text{ V}$$

Resistance ratio = voltage ratio

$$R = 495 \Omega$$

or

$$I = 0.80 \text{ V}/330 \Omega \text{ (substitution)}$$

$$= 0.002424 \text{ A}$$

$$V \text{ across thermistor} = 1.20 \text{ V}$$

$$R = 1.20 \text{ V}/0.002424 \text{ A}$$

$$= 495 \Omega$$

or

$$I = 0.80 \text{ V}/330 \Omega$$

$$= 0.002424 \text{ A}$$

$$R_{\text{(total)}} = 2.0 \text{ V}/0.002424 \text{ A}$$

$$= 825 \Omega$$

$$R = 825 \Omega - 330 \Omega$$

$$= 495 \Omega$$

3

Explanation:

Thermistor resistance low

Why: thermistor hotter/more current, power, charge carriers

Why v. small: thermistor takes smaller fraction of p.d. *or* ratio of p.d.

3

[8]

49. Slope of graph:  
 Capacitance  
 Shaded area of graph:  
 Energy/work done 2  
 Energy stored 3.1 J:  
 $CV^2/2$   
 $= 100 \times 10^{-6} \times 250^2/2$  [formula + correct substitution]  
 $(= 3.125) = 3.1$  J [Must have previous mark] 2  
 Power from cell, and minimum time for cell to recharge capacitor:  
 Cell power =  $1.5 \text{ V} \times 0.20 \text{ A}$   
 $= 0.30 \text{ W}$  [allow 3/10 W here]  
 Time =  $3.1 \text{ J}/0.30 \text{ W}$  (e.c.f.)  
 $= 10 \text{ s}$  3

[7]

50. Energy transfer:  
 From power supply to the element  
 [Not ordered process electrical NIIt]  
 Working  
 Supply pushes/moves/sends current/charge/electrons along wire/through element  
 [Need idea of a force and a displacement]  
 or supply not hotter than element so not heating/process independent of temperature  
 [2<sup>nd</sup> mark depends on 1<sup>st</sup> mark awarded]  
 From element to the surrounding air  
 Heating [Not convection/radiation]  
 Element hotter than the air/energy down temperature gradient  
 or element doesn't push air and move it, so not working

[4]

[2<sup>nd</sup> mark depends on 1<sup>st</sup> mark awarded]

51. (a) (i) Reference to (individual) nuclei/atoms/particles  
 Each has a chance of decay/cannot predict which/when will decay 2  
 (ii) Use of  $\lambda t_{1/2} = \ln 2$   
 $\rightarrow \lambda = \ln 2 \div 600 \text{ s} = 1.16/1.2 \times 10^{-3} \text{ s}^{-1}$   
 $\therefore A = (1.16 \times 10^{-3} \text{ s}^{-1}) (2.5 \times 10^5)$  [Ignore minus sign]  
 $= 288/290 \text{ Bq/s}^{-1}$  [c.a.o.] [Not Hz] [17 300  $\text{min}^{-1}$ ]  
 (iii)  ${}^{13}_7\text{N} \rightarrow {}^0_1\text{e} / {}^0_1\beta + {}^{13}_6\text{C} / X (+ \nu_e)$  [N/O/C/X] [e.c.f.  $\beta^-$ ]  
 $[\beta^+$  on left, max 1/2] 5

- (b) (i) (Volume/level of)  $\text{CuSO}_4$  in burette =  ${}^{13}_7N$   
 Burette empties but N never reaches 0  
 (Volume of)  $\text{CuSO}_4$  in beaker =  ${}^{13}_6C/X$   
 Drops represent decay [accept represent  $\beta^+$ ]  
 (but) there is no randomness  
 and no particle given off  
 Exponential fall or rise in burette or beaker Max 3 marks
- (ii) Use of  $R = \rho l/A$   
 $= (0.12 \Omega \text{ m})(0.050 \text{ m}) \div (0.02 \text{ m} \times 0.04 \text{ m})$  [Ignore units]  
 [Beware  $(0.04)^2$ ]  
 $= 7.5 \Omega$  [e.c.f. 3.75  $\Omega$ ]  
 Add to 5.6  $\Omega$  [e.c.f.]  
 So  $I = V/R = 1.5 \text{ V} \div (5.6 \Omega + 7.5 \Omega)$  [e.c.f.]  
 $= 0.1145 \text{ A}/0.115 \text{ A}/0.114 \text{ A}/0.11 \text{ A}/0.1 \text{ A}$  [c.a.o.]  
 Assume: d.c. supply zero  $R$ / current perpendicular to plates.  
 E field perpendicular/ammeter  $R$  zero/no e.m.f. in beaker (e.g. bubbles) /  
 concentration electrolyte constant  
 [Not temperature constant] 6

[16]

52. The joule in base units:

$$\text{kg m}^2 \text{ s}^{-2} \text{ [No dimensions] (1)} \quad 1$$

Homogeneity of formula:

$$\rho \quad \text{kg m}^{-3} \text{ (1)}$$

$$r \quad \text{m}, f = \text{s}^{-1} \text{ (1)}$$

$$\begin{aligned} \text{(Right hand side units} &= (\text{kg m}^{-3}) (\text{m})^5 (\text{s}^{-1})^2 \text{ [Correct algebra]} \\ &= \text{kg m}^2 \text{ s}^{-2} \text{ [Only if 1}^{\text{st}} \text{ two marks are earned] (1)} \end{aligned} \quad 3$$

[Ignore numbers; dimensions OK if *clear*]

Why formula might be incorrect:

$$\text{The } \frac{1}{2} \text{ could be wrong (1)} \quad 1$$

[5]

53. Definition of symbols:

$n$  = number of electrons/carriers per unit volume (per  $\text{m}^3$ )  
OR  
electron (or carrier) density (1)

$v$  = average (OR drift) velocity (OR speed) (1) 2

Ratio	Value	Explanation
$\frac{n_y}{n_x}$	1	Same material (1) (1)
$\frac{l_y}{l_x}$	1	Connected in series/Kirchoff's 1 <sup>st</sup> law/conservation of charge/current is the same (1) (1)
$\frac{v_y}{v_x}$	2	$A$ is halved so $v$ double [Accept qualitative, e.g. $A \downarrow$ so $v \uparrow$ , or good analogy] (1) (1)

6

[Accept e.g.  $n_y = n_x \dots$ ]

[No e.c.f.]

[NB Mark value first, without looking at explanation. If value correct, mark explanation. If value wrong, don't mark explanation *except*: if  $v_y/v_x = 1/2$  or 1:2, see if explanation is correct physics, and if so give (1). No e.c.f.]

[8]

54. Calculation of voltages:

Any use of

Voltage = current x component resistance (1)

Ballast = 150 V (1)

Filament = 25 V (1) 3

Voltages on diagram:

3 voltages (150,25,25) marked on diagram near component; ignore units (1)

[Minimum  $150 \div (1 \times 25)$ ]

$V_{\text{starter}} = 30 \text{ V}$  (marked on diagram) (1)

Fundamental change necessary:

(Free) charge carriers or free electrons, ionised, *particles* need to be charged (1) (1)

[NOT T  $\uparrow$ ] 3

Calculation of power dissipated:

$$V_{\text{ballast}} = 230\text{V} - 110\text{V} \text{ (1)}$$

$$I = 120\text{V}/300\ \Omega$$

$$= 0.40\text{ A} \text{ (1)}$$

$$\text{Power} = 230\text{ V} \times 0.40\text{ A [e.c.f for current]}$$

$$= 92\text{ W} \text{ (1)}$$

3

Faulty component:

Starter is not breaking the circuit/starter still conducting (1)

1

[10]

55. Demonstration that resistance is  $0.085\ \Omega$ :

$$R = \rho l/A \text{ (1)}$$

$$= 1.7 \times 10^{-8}\ \Omega\text{m} \times 20\text{ m} / (4.0 \times 10^{-6}\ \text{m}^2) \text{ (1)}$$

2

Calculation of voltage drop:

$$V = 37\text{ A} \times 0.085\ \Omega \text{ (1)}$$

$$= 3.1\text{ V} \times 2 = 6.3\text{ V [Not if } V_{\text{shower}} \text{ then found]} \text{ (1)}$$

2

[Only one conductor, leading to 3.1 V, gets 1<sup>st</sup> mark]

[Nothing if wires in parallel]

Explanation:

Lower resistance/ $R = 0.057\ \Omega$ /less voltage drop/new  $V = \frac{2}{3}$  old  $V$  (1)

Power dissipated in cable/energy wasted/wire not so hot

OR more p.d/current/power to shower

OR system more efficient (1)

2

[6]

56. Diagram of apparatus to demonstrate Brownian motion in a gas:

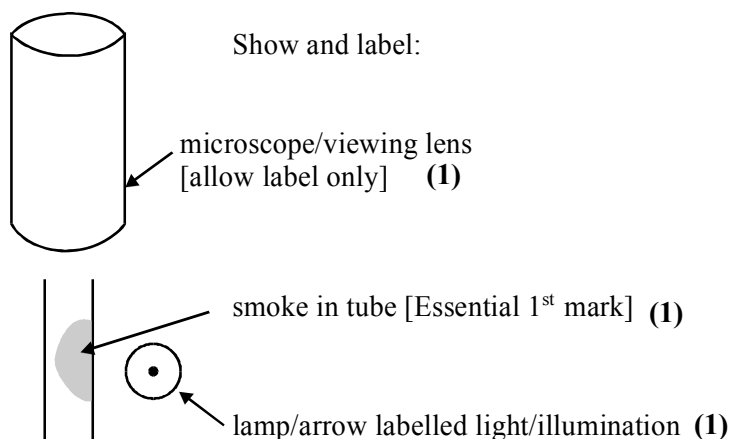

3

Description and explanation re evidence for molecular constitution of a gas:

(Smoke) particles/bright specks moving irregularly/randomly/dancing (1)  
[NOT air]  
due to colliding air molecules/gas molecules (1)

Further significant detail, e.g. air molecules can't be seen, uneven (1)  
collisions produce resultant force, air molecules high speed to move  
heavier smoke

3

[Can still get these marks if diagram is incorrect or missing]

[6]

57. Demonstration that energy given to block is about 300 J:

$$E = VIt \text{ OR } P = vI \text{ and } E = Pt \text{ (1)}$$

$$Q = It \text{ and } E = Qv$$

$$= 0.42 \text{ V} \times 23 \text{ A} \times 30 \text{ s}$$

$$= 290 \text{ J}/289.8 \text{ J [NOT 300 J] (1)}$$

2

Values of terms in equation with reasons: [Values, NOT just + / -] (1)

$$\Delta U: 290/300 \text{ J}$$

It is the increase/gain in internal energy OR it is  $\Delta Q + \Delta W$  (if consistent with their figures) (1)

$$\Delta Q: 0 \text{ (1)}$$

Thermally insulated OR neither gaining nor losing energy by heating (1)

$$\Delta W: 290/300 \text{ J (1)}$$

Work done by supply OR electrical work done (1)

6

Calculation of average force applied by hammer: (1)

$$W = Fd$$

$$W = \frac{1}{2} Fd \text{ (1)}$$

$$290 \text{ J} = F \times 0.0024 \text{ m}$$

$$290 \text{ J} = \frac{1}{2} F \times 0.0024 \text{ (1)}$$

$$\text{Force} = 121 \text{ kN}$$

$$\text{Average} = \frac{1}{2} F = 121 \text{ kN (1)}$$

[Accept 125 kN (from 300 J)]

3

[11]

58. Calculation of air pressure at 100 °C:

$$\text{Pressure} = 1.00 \times 10^5 \text{ Pa} \times 373 \text{ K} / 273 \text{ K} \quad (1)$$

[If  $T$  in °C  $\rightarrow$  0/2]

$$= 1.37 \times 10^5 \text{ Pa} / \text{N m}^{-2} \quad (1)$$

2

Graphs to show how air pressure varies with temperature (line A) and how different pressure then varies over same temperature range (line B):

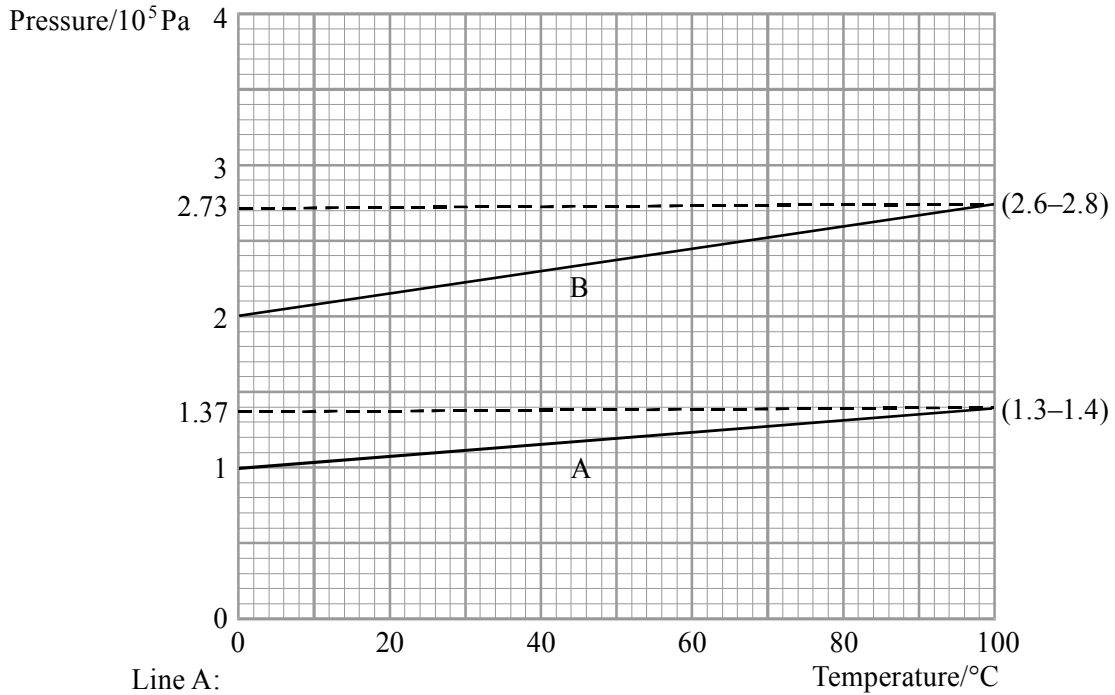

Line A:

Any rising straight line (1)

through correct points [e.c.f end point] (1)

2

Line B:

Rising straight line above line A for all its length (1)

through correct points [e.c.f both points] (1)

2

[6]

59. (a)

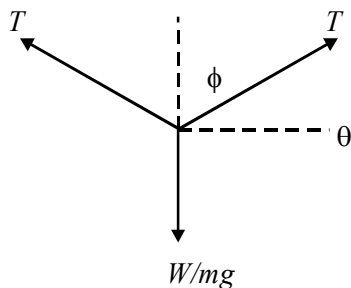

Two  $T$  arrows and one  $mg$  /  $W$  arrow [Labels not required] (1)

Trigonometry to give  $\theta = 3.34^\circ / \phi = 86.66^\circ$  [Method mark] (1)

(Resolving vertically)  $2T \cos \phi / 2T \sin \theta = W/mg$  [no  $2 \times \rightarrow$  max 3/5 eop]

Substitution in  $T = 2mg \div \cos \phi / \sin \theta$

= 4.2 N [e.c.f sin/cos confusion] 5

(b) Ammeter and voltmeter (not ohmmeter) in circuit [could be described] (1)

Method of varying current (1)

$R = V/I$  stated anywhere [e.g. gradient  $I/V$  OR  $V/I$  curve] (1) 3

(c) (i) 13 A r.m.s. has same heating effect as 13 A d.c. (1)

(ii)  $\lambda = 2 \times 0.606$  m (1)

Use of  $c = f\lambda$  (1)

$f = 50$  Hz (1)

$\rightarrow c = 60.6 \text{ m s}^{-1} / 121 \text{ m s}^{-1}$  [e.c.f.  $\lambda = 0.60 \rightarrow 30 \text{ m s}^{-1}$ ] (1)

(iii) *Either*

mention of resonance/standing wave (1)

driving force  $f$  equal to natural  $f_0$  (1)

*Or*

Hot-cold cycle (1)

leads to pull-relax forces on the wire (1) 6

(d) Units for  $\mu c^2$ :

$\text{kg m}^{-1} \times (\text{m s}^{-1})^2$  (1)

=  $\text{kg m s}^{-2}$  which is N (1) 2

[16]

60. Correct quantities on diagram:

Upper ellipse capacitance [not energy] [Accept capacitance<sup>-1</sup>] (1)

Lower ellipse resistance [not power] [Accept conductance/resistance<sup>-1</sup>] (1)

2

Explanation:

Base quantities/units [Not fundamental] (1)

Not derived from other (physical) quantities (1)

OR other (physical) quantities are derived from them

OR cannot be split up/broken down

2

[4]



61. Proof:

$$V = V_1 + V_2 \qquad V = V_1 + V_2 \qquad (1)$$

$$V = IR \qquad V_1 = IR_1 \qquad V_2 = \div I \qquad (1)$$
  
$$IR_2$$

Substitute **and** cancel  $I$  \qquad Sub using  $R =$  \qquad (1)

3

Explanation of why it is a good approximation:

Resistance of connecting lead is (very) small \qquad (1)

So  $I \times R_{(\text{very}) \text{ small}} = (\text{very}) \text{ small p.d.}/e^{-1}$ s do little work so p.d. small/ $r$  small \qquad (1)

compared with rest of the circuit so p.d. small \qquad 2

Circumstances where approximation might break down:

If current is large **OR** resistance of rest of circuit is small \qquad (1)

[**Not** high voltage/long lead/thin lead/high resistivity lead/hot lead] \qquad 1

Calculation:

Use of  $R = \frac{\rho l}{A}$  with  $A$  attempted  $\times$  sectional area \qquad (1)

Correct use of 16 \qquad (1)

Use of  $V = IR$  \qquad (1)

0.036 V \qquad (1)

4

[10]

62. Description of motion:

AB: uniform acceleration OR  $v$  increases at constant rate \qquad (1)

[**Not** accelerates constantly]

BC: sudden deceleration OR slows down/stops rapidly \qquad (1)

2

Explanation of cause of motion:

AB: Attraction to positive/power supply/the voltage/energy of supply/(electric) force from supply OR electric field (in wire) \qquad (1)

BC: collision with ion/atom/electron/nucleus/lattice \qquad (1)

2

Explanation of term *drift velocity*:

Drift velocity: average mean/net/overall velocity of electron along wire (1)

[Not speed]

Value shown on graph (allow between 1/3 and 2/3 of maximum velocity) (1)

[Line or mark on graph axis, label not needed if only one line/mark]

2

Explanation of why wire gets warm:

Collision makes ion/atom vibrate more vigorously

OR in collision energy is transferred to lattice (1)

1

[7]

63. Calculation:

Use of  $\Delta Q = \Delta mL$  and  $\Delta Q = P\Delta t$  (1)

[ $t = \text{energy/power} = 0.5 \text{ kg} \times 2.2 \times 10^6 \text{ J kg}^{-1} / (2.4 \times 10^3 \text{ W})$ ]

= 460 s [458] (1)

2

Demonstration that volume is approximately  $0.9 \text{ m}^3$ :

$pV = nRT$  (1)

$V = nRT/p = 27.8 \text{ mol} \times 8.31 \text{ J K}^{-1} \text{ mol}^{-1} \times 373 \text{ K} / (1.01 \times 10^5 \text{ Pa})$  (1)

=  $0.853 \text{ (m}^3)$  [must give to at least 2 s.f.] [Not  $0.9 \text{ m}^3$ ] (1)

3

Calculation:

$W = p\Delta V$  OR  $pV$  (1)

=  $1.01 \times 10^5 \text{ Pa} \times 0.853 \text{ m}^3$  [0.85  $\text{m}^3$ , 0.9  $\text{m}^3$  OK] (1)

=  $8.62 \times 10^4 \text{ J}$  [ $8.61 - 9.08 \times 10^4 \text{ J}$ ] (1)

[NO e.c.f. – must be true answer]

3

Values of terms in equation:

$\Delta Q = 0.5 \text{ kg} \times 2.2 \times 10^6 \text{ J kg}^{-1} = 1.1 \times 10^6 \text{ J}$  (1)

$\Delta W = -8.62 \times 10^4 \text{ J}$  [Must be negative] (1)

$\Delta U = \Delta Q + \Delta W = 1.014 \times 10^6 \text{ J}$  [e.c.f. using their values] (1)

3

[Only penalise unit once]

[11]

64. Sketch graph showing:
- $p$  decreasing as  $V$  increases [Accept straight line] (1)
- Smooth curve, asymptotic to both axes [Not touching or going to touch] (1)
- 2

Explanation of shape of graph:

- As  $V$  increases:
- packing density of the molecules decreases
- OR molecules travel further between collisions (1)
- [Look for change in molecular spacing]
- Collision (rate) with walls decreases OR change in number of collisions with walls [Ignore reference to intermolecular collisions] (1)
- 2

How to calculate pressure of air in the syringe:

- [NB Not gauges/manometers/ $pV$  method]
- Weight (of mass)  $\div$  area of piston [no need for  $Xle$ ] (1)
- plus atmospheric pressure (1)
- [Penalise if wrong area]
- 2

Suggested possible source of error:

- Any *one* from:
- temperature not constant
  - leakage of air OR mass of gas not constant
  - weight of piston not included
  - friction (1)
- 1

[Not non-uniformity of tube/dead space]

[7]

65. (a) Kinetic energy (1)
- Elastic/spring/strain energy [Not potential] (1)
- [ignore reference to internal energy/heat] (1)
- 2
- (b) (i) (Use of)  $pV = \text{constant}$  (1)
- Evidence for new  $p = 138 \text{ kPa}$  (1)
- $\therefore \Delta p = (138 - 116) \text{ kPa} = 22 \text{ kPa}$  [NB 22 kPa given] (1)

- (ii) Molecules are closer together/have less space/volume (1)  
 [Not simply volume less]  
 Speed/ke/ of molecule increases (1)  
 [Not simply energy]  
 More collisions (with walls) (1)  
 Collisions more violent (with walls) OR (1)  
 6

Reference to momentum/change of momentum

- (c) (i) Use of  $a = 33.5 \times 10^{-3} \text{ m}$  and  $m = 57.5 \times 10^{-3} \text{ kg}$  (1)  
           (0.0335 m)           (0.0575 kg)  
 Any  $\Delta p$  chosen in range 16 kPa to 48 kPa (1)  
 $\Rightarrow c = 8.1 \text{ m s}^{-1}$  to  $14.0 \text{ m s}^{-1}$   
 $[22 \text{ kPa} \rightarrow 9.5 \text{ m s}^{-1}; 32 \text{ kPa} \rightarrow 11.5 \text{ m s}^{-1}; 38 \text{ kPa} \rightarrow 12.5 \text{ m s}^{-1}]$  (1)  
 Pulse travels half way round i.e.  $\pi a$  OR 0.105 m (1)  
 so  $t_c = 0.105 \text{ m} \div c$  [NB method mark] (1)  
 $\Rightarrow 13 \text{ ms}$  to  $7.5 \text{ ms}$   
 [If algebra done first  $t_c = \sqrt{m\pi / 2a\Delta p}$  in place  
 of middle two marks] (1)(1)  
 5

- (ii) Device: pressure pad [Not switch] /narrow beam at wall (1)  
 level/rapid photography [Not video] [Accept flash]/Al foil on  
 ball (plus conducting wall) (1)  
 How does it work: conducts/light gate/repetitive/conducting wall  
 (complete circuit) (1)  
 How is time known: scaler timer OR c.r.o./count photos OR  
 datalogger OR RC OR computer (1)  
 3

[16]

66. (a) (i) Centre line with arrow down (1)  
 More lines on either side (1)

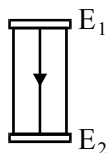

Either showing bulges at edges

- (ii)  $E = 6.0 \text{ V} \div 0.15 \text{ m}$  (1)  
 $= 40 \text{ V m}^{-1}$  [ $0.40 \text{ V cm}^{-1}$ ] OR  $40 \text{ N C}^{-1}$  (1)  
 [e.c.f.  $\div 0.075 \text{ m}/7.5 \text{ cm}$ ] (1)  
 (iii) Centre line horizontal (1)

Two more lines (accept horizontal) (1)

OR showing correct curvature/perpendicular to field lines

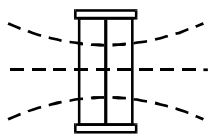

(1)

7

(b) (i)  $V_X = 3.0 \text{ V}/3 \text{ V}$  (1)

because potential at Y is  $3.0 \text{ V}/3 \text{ V}$  (1)

so p.d. across mA is zero OR mA is connected to points at the same potential [an independent mark] (1)

(ii) *Either*

Any reference to Y/change the resistors/change one of the resistors/use a rheostat

Or

V for mA move probe over paper (1)

Locate points where mA reads zero, add 3 V to V OR move Y to 0 V (1)

5

(c) (i) (Use of)  $R = \rho l/A$  (1)

Substitute  $l = x$  and  $A = xt$  (1)

(ii)  $R = \rho/t \Rightarrow \rho = Rt$  (1)

$\rho = (1000 \Omega)(0.14 \times 10^{-3} \text{ m}) = 0.14 \Omega \text{ m}$  [no e.c.f.] (1)

4

[16]

67. Number of carriers or electrons per unit volume / per  $\text{m}^3$  /carrier density/electron density (1)

[Not charge density / concentration]

Drift velocity OR drift speed OR average/mean/net/overall velocity (1) 2

[Not just velocity; not speed unless drift]

$\text{m}^{-3}$  (1)

$\text{m}^2 \text{ As m s}^{-1}$  (1)

Multiply and reduce to A (1) 3

[Base units not needed]  
 [Mixed units and symbols could get the third mark]  
 [mA = m<sup>-1</sup> loses 1 mark]

Metal:

M:  $n$  large so there is a current

$n$ :  $n$  in metal much larger (1)

Insulator

I:  $n$  zero (negligible)/very small so less current (or zero current)

Current in metal is larger (1)

2

[Ignore anything about  $v$ . Allow e.g. electron density for  $n$ ]

[7]

68. Use  $R = \rho/l/A$  OR correct rearrangement OR plot  $R \rightarrow l$  gradient =  $\rho/A$  (1)  
 [Symbols or words]

With  $A = tw$  (1)

2

$l = RA/\rho$  [Rearrangement mark symbols or numbers] (1)

Use of  $A = tw$  (1)

[Correct physical quantities substituted but ignoring unit errors, powers of 10]

= 110 m

[111 m] (1)

3

Reduce width/ $w$  of strip OR use thinner/ $t$  foil [Not reduce  $A$ ; not increase  $T, V, I$ ] (1)

Smaller  $w/t/A$  will be less accurate OR have larger error OR larger  $R$  will be more accurate (1)

2

[Increase  $w$  or  $t$ , could give e.c.f. to increased accuracy]

[7]

69.  $I^2 R / (\mathcal{E}I - I^2 r) / \frac{(\mathcal{E} - Ir)^2}{R}$  (1)

$I^2 r / (\mathcal{E}I - I^2 r) \frac{(\mathcal{E} - Ir)^2}{R}$  (1)

$\mathcal{E}I$  OR  $I^2 R + I^2 r / \mathcal{E}^2 / (R + r)$  (1)

$\mathcal{E}I = I^2 R + I^2 r$  OR  $(It = I^2 RT + I^2 rt / \text{their (iii)} = \text{their (i)} + \text{their (ii)})$  (1)

Cancel  $I$  (OR  $I$  and  $t$ ) and arrange [only if energy equation is correct] (1)

5

Maximum current occurs when  $R = 0$  (1)

$I_{\max} = \varepsilon/r$  (1) 2

OR larger  $r$  means smaller  $I$  (1 mark)

1 M $\Omega$  [Could be underlined OR circled] (1)

It gives the smallest current (1)

[If 100 k $\Omega$  this reason: 1 only] 2

[9]

70. No, because  $V$  is not proportional to  $I$  OR not straight line through origin / (1)  
only conducts above 0.5 V / resistance changes 1

Use of  $R = 0.74$  / current from graph (1)

= 9.25  $\Omega$  [9.0 – 9.5  $\Omega$ ] [Minimum 2 significant figures] (1) 2

Calculation of p.d. across $R$ [8.26]	Calculation of total resistance [109 – 115]	Ratio $R$ : ratio $V$	$E = \Sigma IR$ (1)
$\div I$	– diode resistance [9]	Correct substitutions	Correct substitutions (1)
103 $\Omega$ [100 – 106] (1)			

3

[If not vertical line, 0/2]

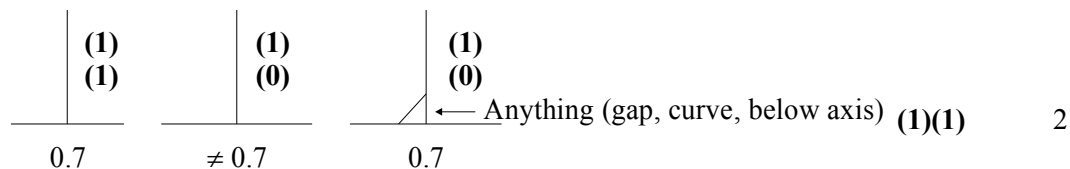

[Otherwise 0 0]

[8]

71. Molecules get closer together (1)

PE molecules increase [Not k.e. increases, but ignore] (1)

Arrangement becomes disordered / regular arrangement breaks down lattice structure (1)

Bonds broken/weaken/overcomes intermolecular forces  $\rightarrow$  melting  
[Not forces broken/weaken] (1)

Molecules start to translate/free to move/ move over/round/  
relative to each other (1)

Max 2

Use of  $E = Pt$  [Allow 36 – 39 minutes] (1)  
 Use of  $E = ml$  (1)  
 $l = 3.3 \times 10^5 \text{ J kg}^{-1}$  (1)  
 [Not converted to s  $\rightarrow 5475 \text{ J kg}^{-12}$ , gets 2/3] 3  
 Thermometer and clock OR Temperature sensor and datalogger  
 [Not just computer] (1)  
 Read thermometer at regular or frequent times OR Records temperatures at regular intervals (1)  
 [If interval specified allow = 10 min] 2  
 Lid / stir / keep thermometer away from heater / how to avoid parallax  
 Thermal equ heater /power supply constant/heater totally submerged (1) 1  
 Single horizontal line at  $29^\circ\text{C}$  (1)  
 Both gradients greater than water's (1)  
 Flat bit shorter than water [if two sloping bits are shown] (1) 3

[11]

72.  $\rho = Nm/V$  (1) 1  
 $p = 2/3 (N/V) \frac{1}{2} m \langle c^2 \rangle / \langle c^2 \rangle \propto \text{k.e.} / m \langle c^2 \rangle \propto \text{k.e.}$  (1)  
 [Full backwards argument can get 1 / 2; full qualitative argument scores 1 / 2]  
 $\text{k.e. (or } \frac{1}{2} m \langle c^2 \rangle \text{ or } \langle c^2 \rangle) \propto T, \therefore p \propto T$  (1) 2  
 $V$  constant (1)  
 $N$  constant / for fixed mass / fixed number of moles [Not fixed amount] (1)  
 [Near ideal conditions, specified, can replace one of the above]  
 [Fixed density, 1 mark] 2  
 See (273, 308) or 404 (1)  
 Use  $P_1/T_1 = P_2/T_2$  (kelvin temp) (1)  
 $= 456 \text{ kPa}$  (1)  
 [355 kPa gets 3 marks]  
 [303 kPa  $\rightarrow$  342 kPa, 101 kPa  $\rightarrow$  114 kPa gets 2 marks] 3

[8]

73.  $\Delta U = 0$  (1)  
 Temperature constant / steady state [only if 1<sup>st</sup> mark given] (1)  
 $\Delta W = 600 \text{ J}$  (1)  
 Electrical energy supplied / electrical work done/ $VI$ / $Pt$  (1)  
 [Even if  $\Delta w$  is correct]  
 $\Delta Q = -600 \text{ J}$  [consistent with their  $\Delta U$  and  $\Delta W$  and 1<sup>st</sup> law] (1)  
 To satisfy equation/first law/energy conservation (1)

[6]

74.  $p$  equal throughout fluid OR equal on both piston (1)



$p = F/A$  used in the explanation (OR rearrangement) (1)

Larger area gives larger force (1)

Quality of written communication (1)

OR

Work/energy method:

Work (or energy) in = work (or energy) out (1)

Equal volume changes so large piston moves a shorter distance (1)

Work = force distance, so larger force on large piston (1)

Quality of written communication (1)

[4]

75.  $e$  the electronic charge/the charge on the electron

$n$  the number of electrons

(transferred) per second/per unit time

$\frac{1}{2}$  has no units/is dimensionless

[4]

76. (a) Circuit P:

*Either*

$$\text{Use of } \frac{1}{R} = \sum \frac{1}{R_n}$$

$$R = \frac{24\Omega}{8} = 3.0\Omega$$

$$\therefore I = \frac{12V}{3\Omega} = 4.0 \text{ A}$$

Or

$$I \text{ in one element} = \frac{12V}{24\Omega} = 0.5A$$

$\therefore$  total  $I = 8$  times this

$$= 8 \times 0.5 \text{ A} = 4.0 \text{ A}$$

3

Circuit S:

$$R = \sum R_n = 8 \times 0.5\Omega$$

$$\therefore I = \frac{12V}{4\Omega} = 3.0A$$

2

(b) Circuit P:

$$\text{New } R = \frac{24\Omega}{6} = 4.0\Omega$$

$$\rightarrow \text{new } I = 3.0 \text{ A}$$

Circuit S:

New current is zero

2

(c) 12 V down to 6 V  $\rightarrow$  halving  $I$  or  $I = 2 \text{ A}$  or new  $P = (\frac{1}{2} V)^2/R$

So new  $P = \frac{1}{2} V \times \frac{1}{2} I = \frac{1}{4} P$  original

2

[9]

77. Correct symbol for LDR (1)  
 d.c. source in series with (1)  
*either* ammeter and LDR  
 or LDR and resistor with voltmeter across resistor (1) Max 2  
 $R_{\text{LDR}}$  decreases with increasing incident light intensity  
 Whence increase in A or V reading 2

[4]

- g-text; 78. Metal wire:  
 straight line through origin  
 Semiconductor diode:  
 line along V axis for negative I  
 curve up in first quadrant 3  
 in gap  
 p.d. across it (4.5 – 1.9) V  
 $\therefore R_S = \frac{2.6\text{V}}{20 \times 10^{-3}\text{A}} = 130\Omega$  3

[6]

79.  $R = \rho \frac{1}{A}$  [no mark]  
 Use of  $A = \pi (0.70 \times 10^{-3}\text{ m})^2$   
 Correct substitution to show that  $R = 390\Omega$  (2 significant figures) 2  
 $R/\rho$  changes with  $T/\theta$   
 As  $T/\theta \downarrow (\uparrow)$ ,  $R/\rho \uparrow (\downarrow)$  2  
 $P = IV = I^2R$   
 $= (0.25\text{ A})^2 (420\Omega)$  or  $(0.25\text{ A}) (105\text{ V})$   
 or  $V = IR = 0.25\text{ A} \times 420\Omega = 105\text{ V}$   
 $= 26\text{ W}$   
 or  $P = IV = 0.25\text{ A} \times 105\text{ V} = 26\text{ W}$  2  
 The power transfer/26 W (1)  
 Heats/warms/raises the temperature of the pencil lead (1)  
 so reducing its resistance (1)  
 and hence raising the current (1)  
 Quality of written communication (1) Max 3

[9]

<b>80.</b>	Diagram: Heater in aluminium block with suitably placed thermometer Lagging round the surface of the block and a circuit diagram with correctly placed voltmeter, ammeter and power supply	3	
	Measure the mass of the block ( $m$ ) (1) Record voltmeter and ammeter readings ( $V$ and $I$ ) (1) Note time ( $t$ ) heater on (1) and initial ( $\theta_1$ ) and final ( $\theta_2$ ) temperature of block (1) Energy transferred to block = $IVt$ (1) Increase in internal energy of block = $mc(\theta_2 - \theta_1)$ (1) Specific heat capacity of aluminium $c = \frac{IVt}{m(\theta_2 - \theta_1)}$ (1)	Max 6	<b>[9]</b>
<b>81.</b>	Energy received at/from hot junction/water/source Energy goes to cold junction/water/sink and motor	2	
	Transfers at hot/cold junctions - heating because (they are driven by) temperature difference Transfer at motor - working as forces are moving charges/there is no temperature difference Quality of written communication	5	
	Increase temperature difference Reference to correct expression for efficiency	2	<b>[9]</b>
<b>82.</b>	Temperature Amount of gas/mass of/no moles of 2 <sup>nd</sup> curve above given curve going through two correct points, e.g. 2, 400; 2,200; 8,100.	2  2	<b>[4]</b>
<b>83.</b>	$\left(\frac{3.4}{2.0}\right)^3 \Rightarrow 4.9$ $p_1V_1 = p_2V_2$ $p_2 = 496 \text{ kPa}$ (accept 495 kPa – 505 kPa) $\Delta p = 395 \text{ kPa}$ (accept e.c.f.) Yes/No Because $\Delta T$ is/may be 10K/10°C So (yes) $285 \div 275$ very nearly 1/so(no) which is 3%	1   3  no mark  2	<b>[6]</b>

84.

	Base unit	Derived unit	Base quantity	Derived quantity	
Mass			✓		(1)
Charge				✓	(1)
Joule		✓			(1)
Ampere	✓				(1)
Volt		✓			(1)

5

[5]

85. Ammeter resistance: zero OR very small/0/negligible (1)  
 Voltmeter resistance:  $\infty$  OR very large/huge (1)

Calculation:

Four  $5 \Omega$  in parallel:  $1.25 \Omega/1.3 \Omega/1.0 \Omega$  (2)

[1 mark: correct substitution into formula]

[Do NOT accept  $5/4 \Omega$ ]

4

[4]

86. Explanation:

As the temperature rises, the resistance decreases (1)

As the resistance decreases, so the ammeter reading/current increases (1)

[No mention of resistance 0/2]

[Current controls temperature  $\rightarrow$  controls  $R$  is wrong physics – 0/2]

[If  $T$  changes so  $R$  changes OR vice versa so  $I$  changes 1 mark only]

[Correct static relationship (extremes) 1 mark only]

Reading on milliammeter:

At  $20^\circ\text{C}$   $R = 1.4 \text{ (k}\Omega\text{)}$  (1)

Substitute correctly in  $V = IR$  i.e.  $6 \text{ V} = I \times 1400 \Omega$  (1)

[Allow their incorrect  $R$ ; ignore  $10^x$ ] (1)

Milliammeter reading =  $0.0043 \text{ A}$  OR  $4.3 \text{ mA}$  [no e.c.f.] (1)

[Accept  $4 \text{ mA}/4.2 \text{ mA}$ ]

5

[5]

87. Current:

Conversion, i.e.  $0.94 \times 10^{-3} \text{ m s}^{-1}$  (1)

Use of  $1.6 \times 10^{-19} \text{ C}$  (1)

Answer  $3.0 \text{ A}$

$1.0 \times 10^{29} \text{ m}^{-3} \times 0.20 \times 10^{-6} \text{ m}^2 \times 1.6 \times 10^{-19} \text{ C} \times 0.94 \times 10^{-3} \text{ mm s}^{-1}$  (1)

Current =  $3.0 \text{ A}$  [Accept  $2.8 \text{ A}$  if  $0.9 \times 10^{-3}$  used.]

3

Resistance:

Recall  $R = \frac{\rho l}{A}$  (1)

Substitution:

$$R = \frac{1.7 \times 10^{-8} \Omega \text{ m} \times 4.0 \text{ m}}{0.20 \times 10^{-6} \text{ m}^2} \quad (1)$$

Resistance = 0.34  $\Omega$  (1) 3

Potential difference:

Potential difference = 3.0 A  $\times$  0.34  $\Omega$  (1)

= 1.0 V (1.02 V)

[Mark for correct substitution of their values or for the answer of 1.0 V] 1

Explanation:

(Increasing resistivity) increases resistance (1)

Leads to a smaller current (1) 2

Comparison:

Drift velocity decreases (in second wire) (1) 1

[Allow  $V_1/V_2 = I_1/I_2$ ]

[Allow e.c.f. answer consistent with their current answer]

[Resistivity up, current down

$\rho$  up,  $I$  down / 2 (2<sup>nd</sup> mark)]

[10]

88. Advantage of polished wood:

Underside:

Infrared radiation/radiation [NOT heat; allow radiant] (1)

is reflected downwards [towards grill/warm people etc] (1)

Upper surface:

Aluminium is poor emitter/minimises or reduces loss of heat (1)  
to the region/air above/environment/surrounding (1) 4

Total energy:

= 14.4  $\times$  10<sup>3</sup> W  $\times$  [16  $\times$  3600 s]

= 829 440 000 J

= 8.3  $\times$  10<sup>8</sup> J [NOT 8.0  $\times$  10<sup>8</sup> J]

Conversion to watts (1)

Conversion to seconds (1)

Correct answer [Need to *see* their answer] (1) 3

Wasted energy:

Wasted energy = 0.55  $\times$  their value or quoted value

= 4.6  $\times$  10<sup>8</sup> J

[Accept 4.4  $\times$  10<sup>8</sup> J if 800 MJ used]

Use of 0.55 or 55% or (55/100) 0.45  $\times$  830 [800] (1)

Multiplication i.e.  $\times$  830[800] Subtract above from 830[800] (1)

[If their initial energy is wrong, allow use of their value for full ecf] (1)

(4.4 or 4.6)  $\times$  10<sup>8</sup> J 3

Efficiency of heater:

When first switched on energy [NOT heat] (1)

Is used to heat grill/device [NOT "hood"] (1)

[It takes time to heat up 1/2]

[Correct reference to temperature difference 1/2] 2

[12]

89. E.m.f.

Use of intercept mentioned/indicated on graph/when  $I = 0$  (1) 2  
e.m.f. = 1.5 V (1)

Use of graph:

Internal resistance: mention use of gradient/use of numbers/triangle on graph (1)

Internal resistance = 0.5  $\Omega$  (1) 2

[Finds  $r$  and/or  $V$  by substitution, can score answer mark, but NOT method mark]

$$\left[ \text{Gradient} = \frac{1.5 - 1.0}{1.0} = 0.5 \Omega \right]$$

They might write gradient =  $\frac{1.5}{1.0} = 1.5 \Omega$  OR gradient =  $\frac{1.5}{1.2}$  - ignore signs ]

Graph:

Negative gradient of a straight line starting anywhere (1)

from (0.0, 3.0) [No e.c.f.] (1)

heading for (1.0, 2.0[1.9  $\rightarrow$  2.1])/gradient of  $-1$  [Consequent mark] 1 3

Filament lamp: any two of

if the variable resistor is set to zero [NOT, as  $R_{VR}$  down] (1)

the lamp prevents  $I$  from becoming too large (1)

and overloading/damaging the ammeter (1)

bulb acting like a fuse OR prevents short circuit (1)

bulb means there is still resistance in circuit (1) Max 2

[9]

90. Variables:

Temperature (of gas) (1)

Amount of gas/mass of gas/number of molecules or moles (1) 2

Diagram to include any three of the following:

• trapped gas/fixed mass of gas (1)

• scale [or see dashed lines] (1)

• method of varying pressure [accept unlabelled syringe] (1)

• measurement of pressure [must label pump; accept P.G.] (1) Max 3

[Balloons drawn – no marks

Any unworkable apparatus – 1 max i.e. e.o.p.

Accept standard apparatus/syringes with pressure gauge/masses on moveable pistons.

Ignore water baths.

Heating experiment scores zero.]

Results:

Reference to finding volume from their measurements

[Accept *volume* scale labelled on diagram] (1)

Label axes (1) 2

e.g.  $P \rightarrow 1/V$  or  $V \rightarrow 1/P$ : [Accept  $p \approx 1/L$  where  $L$  has been identified.

Ignore unit errors on graph]

[7]

91. Explanation:

Quality of written communication (1) 1

Explanation, any two from:

energy [not heat] flows out (1)

at the same rate (1)

due to motor/heat pump (1)

Max 2

$\Delta U$ :

$\Delta U: \Delta U = 0$  (1)

Temperature (of contents) constant/temperature kept at 5 °C (1)

2

$\Delta Q$ :

$\Delta Q$ :  $\Delta Q$  is the net energy flowing (1)

because of the temperature differences (1)

[Do not accept “energy due to heating”]

2

$\Delta W$ :

$\Delta W$ : No work is done on (or by) the contents OR  $\Delta W$  must be zero since

$\Delta U$  and  $\Delta Q$  are zero

OR no mechanical or electrical work done on contents (1)

1

[8]

92.

Word Equation	Quantity Defined	
Voltage $\div$ Current	Resistance	(1)
Voltage $\times$ Current	Power	(1)
Charge $\div$ Time	Current	(1)
Work done $\div$ Charge	Voltage/p.d./e.m.f	(1)

[4]

93. Charge calculation

$Q = 20\,000 \times 4.0 \times 10^{-4}$  s [substitution]

$Q = 8.0$  C/A s

2

Resistance calculation

$$R = \frac{\rho l}{A}$$

$$= \frac{(1.7 \times 10^{-8} \Omega)(50\text{m})}{(1.0 \times 10^{-3} \text{m}^2)}$$

$R = 8.5 \times 10^{-4} \Omega$

Formula (1)  
 Correct substitution (1)  
 Answer (1) 3

Potential difference calculation

$V = IR$   
 $= (20\,000\text{ A}) \times (85 \times 10^{-5}\ \Omega)$  [or their value] (1)  
 $= 17\text{ V}$  [Allow full e.c.f] (1) 2

Explanation

For the tree: R or p is larger (1) 1

[8]

94. Area of contact

Area of tyre =  $\frac{12\,000\text{ N}}{4 \times 3.0 \times 10^5\text{ Pa}}$  (1)  
 $= 0.01\text{ m}^2$  (1) 2

[Allow e.c.f. for no 4, ie. 0.04 m<sup>2</sup> scores one mark]

Air pressure

See  $p/T = \text{constant}$  (1)  
 $p = \frac{3.0 \times 10^5\text{ Pa} \times 303\text{ K}}{283\text{ K}}$  [2<sup>nd</sup> mark is for 303 and/or 283] (1)  
 $3.2 \times 10^5\text{ Pa}$  (1) 3

Graph

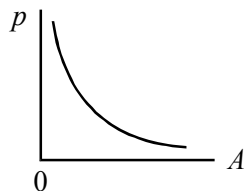

Axis labelled p/pressure  
 Axis labelled A/area [Not contact] (1)  
 Downward line (1)  
 Concave curve, not touching the axes (1) 3

OR

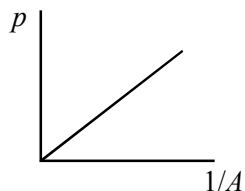

p and 1/A labelled or 1/p and A (1)  
 Positive gradient (1)  
 Straight line through origin (1) 3  
 [Graph with no labelling scores 0/3]

[8]



95. Show that  
 [In diagram or text]

- states p.d. same across each resistor (1)
- use of  $I = I_1 + I_2 + I_3$  [symbols or words] (1)

$$\bullet \quad \frac{V}{R} = \frac{V}{R_1} + \frac{V}{R_2} + \frac{V}{R_3} \quad (1) \quad 3$$

[ $I = V / R$  stated somewhere gains one mark]

Networks

- First network: 2.5(Ω) (1)  
 Second network: 25 (Ω) (1)  
 Third network: 10 (Ω) (1) 3

Meter readings

- Ammeter: 25 (mA) (1)  
 Voltmeter  $V_1$ :  $25 \times 10$  OR  $50 \times 5$  [ignore powers of 10] (1)  
 = 0.25 V (1)  
 Voltmeter  $V_2$ :  $50 \times 25$  [ignore powers of 10] (1)  
 = 1.25 V (1) 5

[Allow full e.c.f. for their resistance for 2<sup>nd</sup> network OR their  $V_1$  answer]

[11]

96. Potential difference across resistors

- 2.0 MΩ: 6.0 V } 5.99998 V } (1)  
 } OR }  
 4.0 Ω: 0V }  $1.2 \times 10^{-5}$  V } (1) 2

Second potential divider circuit

p.d. across 45 Ω:

$$\left( \frac{45}{50} \times 6.0 \text{ V} \right) = 5.4 \text{ V} \quad (1)$$

p.d. across diode:

$$(6.0 \text{ V} - 5.4 \text{ V}) = 0.6 \text{ V} \quad (1) \quad 2$$

[Allow e.c.f. for 2<sup>nd</sup> mark if candidate uses

$$\frac{5}{45} \times 6.0 \text{ V} = 0.7 \text{ V for diode}$$

then

$$6.0 \text{ V} - 0.7 \text{ V} = 5.3 \text{ V for } 45 \Omega]$$

Graph

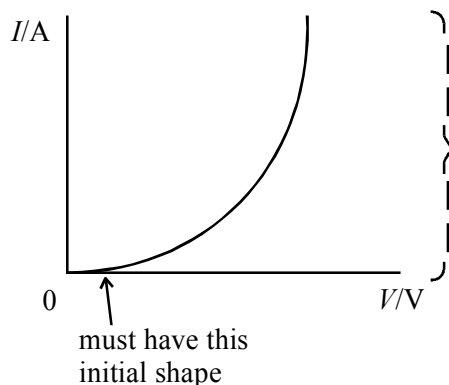

Be leniente here provided generally right shape

(1) 1

[5]

97. Energy calculation

$$\Delta Q = mc\Delta T$$

$$\Delta Q = 0.7 \text{ kg} \times 4200 \text{ J kg}^{-1} \text{ K}^{-1} \times 80 \text{ K} \quad (1)$$

$$\Delta Q = 235\,200 \text{ (J) [or 235 (kJ)] [no u.e.]} \quad (1) \quad 2$$

Time taken

$$\text{Time} = \frac{\text{Energy}}{\text{Power}}$$

$$\frac{235\,200 \text{ J}}{2200 \text{ W}}$$

Formula (1)

Substitution [Allow e.c.f.] (1)

Time = 106.8 s [or 110 s] (1) 3

[Allow use of 250 kJ to give 114 s]

Graph

Temperature becomes constant at the end (1)

Uniform rate of temperature rise/straight line in central region (1)

Initially rate slow, then rate increases, then rate decreases (1) 3

Efficiency

Efficiency = ratio of two times or two energies (1)

in range 0.67 – 0.78 (1) 2

[Allow their calculated time value and time off graph in range 145 s – 160 s]

[10]

98. Heat engine

Work is done/mechanical energy is used (1)

(when) (thermal) energy flows (1)

from hotter/hot source/body to colder/cold body/sink (1)

not all thermal energy is converted to mechanical (1) Max 3

Thermal efficiency

$$\text{Efficiency} = \frac{T_1 - T_2}{T_1} \quad (1)$$

Conversion to kelvin (1)

$T_1$  and  $T_2/\theta_1$  and  $\theta_2$  substituted correctly (1)

$$\frac{623 \text{ K} - 268 \text{ K}}{623 \text{ K}}$$

Efficiency = 0.57 (57%) [Correct answer only] (1) 3  
[No e.c.f. to  $\theta$  since efficiency > 1 – 1/3 marks only]

Wasted energy

Any two sensible answers based on energy/work: (2) 2

- work done against friction
- loss of energy through gap at (side of) paddle because of convection
- work done to move/overcome weight of paddle
- loss of energy to (stone) floor
- loss of energy to cook food
- loss of energy to heat paddle

Ratio

$$\frac{\text{k.e. flames}}{\text{k.e. chimney}} = \frac{623 \text{ K}}{268 \text{ K}} = 2.3$$

Idea that k.e.  $\propto T$  (1)  
Ratio = 2.3 (1) 2

[Accept:

$$\frac{268 \text{ K}}{623 \text{ K}} = 0.43 \text{ provided that } \frac{\text{k.e. chimney}}{\text{k.e. flames}} = \frac{268 \text{ K}}{623 \text{ K}} \text{ correctly stated.}$$

[No conversion penalty if  $\theta$  was used in the efficiency calculation. Already penalised.  
Ratio = 70 scores (2)]

[10]

99. First assumption

Observation: Brownian motion in gases/or observe smoke particles under a microscope (1)

Explanation: (Smoke) particles subjected to collisions from (air) molecules (1)

OR

Observation: diffusion of a coloured gas with another gas (1)  
Explanation: complete mixture only occurs due to random motion (1) 2

Second assumption

Observation: A large volume change occurs when change of state to gas occurs (1)

Consequential explanation: Implies large spacing between molecules (1)

OR

Observation: Diffusion is fast(er) in gases (than liquids) (1)

Consequential explanation: Implies there is more spacing for molecular motion (1) 2

[Statements such as “gases are compressible/highly compressible”,  
“boiling water produces a lot of steam” score the first mark for the second assumption.]

[4]

**100.** Unit of current

Amps/ampere (1)

1

Base units of p.d.

*For  $V = IR$  method*

Any three from:

- $V = J C^{-1}$
- $C = A s$
- $J = N m$
- $N = kg m s^{-2}$

[ $kg m^2 s^{-3} A^{-1}$ ]

[See  $J = kg, m^2 s^{-2}$  (1) (1)]

OR

*For  $P = VI$  method*

- Watt is  $J s^{-1} / J/s$
- $V = J s^{-1} A^{-1}$
- $J = Nm$
- $N = kg m^2 s^{-2}$  (1) (1)] (1) (1) (1)

[See  $kg m^2 s^{-2}$  (1) (1)]

3

[4]

**101.** Show that resistance is approximately  $45 \Omega$

$$R = \frac{\rho l}{A}$$

$$R = \frac{5.5 \times 10^{-5} \Omega m \times 0.65 m}{8.0 \times 10^{-7}}$$

$$= 44.7 \Omega \text{ [No u.e.] (1)}$$

[Must see this value and not 45]

Table

Switch X	Switch Y	Resistance of heater/ $\Omega$	
Open	Closed	22.5/22.35	(1)
Closed	Open	45/44.7	(1)
Closed	Closed	15/14.9	(1)

[No u.e.]

3

Calculation of maximum power

$$P = \frac{V^2}{R} \text{ Use of equation with } 15 \Omega \text{ OR their } \textit{minimum} \text{ value (1)}$$

$$= 3526 \text{ W, } 3500 \text{ W [full ecf] (1)}$$

2

Explanation of power output fall

As the temperature of the heater increases } resistance (of metals) increases  
OR as it gets hotter / hot

$$\text{Since } V \text{ is constant } P = \frac{V^2}{R} \text{ OR } P = VI \text{ and } V = IR$$

[Then  $P \downarrow$  as  $R \uparrow$ ] (1)

2

$$\text{OR } P \propto \frac{1}{R} \text{ [so } P \downarrow \text{ as } R \uparrow]$$

[10]

**102.** Explanation of greater drift velocity

(Electrons have greater drift velocity) in the thinner wire (1)

Any two from:

- Same current in both wires
- Reference to  $I = nAQv$
- $nQ$  same in both wires (1) (1)

3

Explanation of higher dissipation of power

(Higher power is dissipated) by the smaller(er)/ low resistor (1)

Any two from:

- Resistors have same p.d. across them
- The small resistor has the largest current [or reverse]
- Power = voltage  $\times$  current, OR voltage<sup>2</sup>  $\div$  resistance [NOT  $I^2R$ ] (1) (1)

3

[6]

**103. Readings on voltmeter**

Use of any resistor ratio OR attempt to find current in *either* circuit **(1)**

At 950 kΩ

$$V = \frac{10 \text{ k}\Omega \times 6 \text{ V}}{960 \text{ k}\Omega} = 0.063 \text{ V (1)}$$

At 1.0 kΩ

$$V = \left( \frac{10 \text{ k}\Omega \times 6 \text{ V}}{11 \text{ k}\Omega} \right) = 5.45 \text{ V (1)} \quad 3$$

Use of circuit as lightmeter

Maximum resistance corresponds to low light intensity/resistance down as light intensity up **(1)**

∴ lightmeter or voltmeter reading will increase as light intensity increases [or reverse] **(1)** 2

[Can ecf for 2<sup>nd</sup> mark if resistance/light intensity incorrect and/or p.d. calculation wrong]

**[5]**

**104. Circuit diagram**

Resistor with another variable resistor/potential divider/variable power pack **(1)**

Ammeter reading current through resistor **(1)**

Voltmeter in parallel with resistor **(1)** 3

Graph labels

Straight line – resistor } Both labelled **(1)** 1  
Curve – lamp }

Potential difference

At 0.5 A p.d. = 3.5 V / 3.4 V + 7.8 V / idea of adding p.d. [for same current] **(1)**  
= 11.2 V / 11.3 V **(1)** 2

[Accept 11.0 – 11.5 V]

Resistance of lamp

$$\frac{3.5 \text{ V}}{0.5 \text{ A}} \text{ [OR their value of p.d. across lamp } \div 0.5 \text{ A]} \text{ (1)}$$
$$= 7.0 \Omega \text{ (1)} \quad 2$$

[e.c.f. their value]

**[8]**

**105. Definition of specific latent heat of fusion**

$$L = \frac{\text{energy}}{\text{change in mass}} / \text{energy to change 1 kg (1)}$$

during a change of state/solid to liquid (1)

at constant temperature/at melting point (1)

3

Explanation of time interval AB

Energy used to break bonds/pull molecules apart/overcome forces of attraction (1)

1

Differences between solid and liquid states

Marks can be scored for diagrams and/or words

Any two rows:

Difference	Solid	Liquid	
Arrangement	Regular array OR lattice	No regular pattern	(1)
Motion	Vibrational motion	Random/Brownian Free to move around (each other)	(1)
Spacing	Close packed	<i>Slightly</i> further apart than in a solid	(1)

Max 2

[6]

**106. Graph illustrates**

$$p_1V_1 = p_2V_2 / pV = \text{constant} / p \propto \frac{1}{V} / p = \frac{\text{constant}}{V} \quad (1)$$

1

Pressure of trapped air

(i)  $1.20 \times 10^5 \text{ Pa (1)}$

(ii)  $0.80 \times 10^5 \text{ Pa (1)}$

2

Length of column

$$(0.80 \times 10^5 \text{ Pa} \times 24.0 \text{ cm}) = (1.2 \times 10^5 \text{ Pa} \times L)$$

$$L = 16.0 \text{ cm [Accept 0.16m]}$$

See one of their pressures  $\times L/24$  (1)

Their upright pressure  $\times L =$  their inverted pressure  $\times 24$  (1)

Answer  $L = 16 \text{ cm (1)}$

3

Assumption about the dry air

Constant temperature (1)

1

[7]

**107. Assumptions**

Elastic collisions (1)

Negligible time for collisions (1) 2

Average force

See  $\left(\frac{1}{3} \times 1.5 \times 10^{24} \text{ molecules}\right)$  (1)

See  $1.6 \times 10^x \text{ kg m s}^{-2} \times \text{a number of molecules}$  (1)

Average force =  $0.8 \times 10^4 \text{ N}$  (1) 3

Gas pressure

Correct substitution in  $p = \frac{F}{A}$  [full ecf their  $F$ ] (1)

$$\left(p = \frac{0.8 \times 10^4}{(0.5 \text{ m})^2}\right)$$

$p = 3.2 \times 10^4 \text{ Pa}$  (1) 2

Meaning of  $\langle c^2 \rangle$

Average/mean (of the) square(s) (of the) velocities/velocity/speeds/speed (1) 1

**[8]**

**108. Principle of operation of heat engine**

Quality of written communication (1) 1

Any three from:

Work is done/mechanical energy

when energy flows/transferred/is taken

from a hotter/hot source/body to a colder/cold body/sink

and *some* is converted to mechanical energy (1) (1) (1) 3

[Diagram only can score maximum of 3 (no Qowc)]

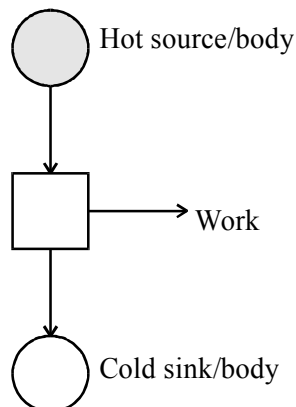



Energy calculation

Energy in cooling water = 135 MJ (1) 1

[May be on diagram]

Efficiency calculation

$$\frac{105}{300} = (0.35) \quad (1) \quad 1$$

[6]

**109.** Resistance of lamps

$$P = \frac{V^2}{R} \quad \text{OR} \quad I = 60/12 = (5 \text{ A}) \quad 1$$

$$R = \frac{12 \text{ V} \times 12 \text{ V}}{60 \text{ W}} \quad \underline{R = V/I} \quad 1$$

$$R = 2.4 \Omega \quad 1$$

Resistance variation

Lamp A: resistance of A decreases with current increase 1

Lamp B: resistance of B increases with current increase 1

Dim filament

Lamps are dim because p.d. across each bulb is less than 12 V 1

Why filament of lamp A is brighter

Bulbs have the same current 1

p.d. across A > p.d. across B/resistance A > Resistance B 1

OR

power in A > power in B 2

[8]

110. Table

Physical Quantity	Typical value	
Resistance of a voltmeter	<b>10 MΩ</b>	1
Internal resistance of a car battery	<b>0.05Ω</b>	1
Internal resistance of an EHT supply	<b>10 ΩM</b>	1
Resistivity of an insulator	<b><math>2.0 \times 10^{15} \Omega\text{m}</math></b>	1
Drift velocity of electrons in a metallic conductor	<b><math>0.3 \text{ mm s}^{-1}</math></b>	1
Temperature of a working filament bulb	<b>3000 K</b>	1

[Mark is lost if 2 or more values are put into one box]

[6]

111. Current in heating element

$p = VI$	$p = \frac{V^2}{R}$	1
$I = \frac{500 \text{ W}}{230 \text{ V}}$	$R = \frac{230^2}{500} / 105.8(\Omega)$	
$I = 2.2 \text{ A}$	$I = 2.2 \text{ A}$	1
		1

Drift velocity

Drift velocity greater in the thinner wire / toaster filament 1

Explanation

Quality of written communication 1

See  $I = nAQv$  1

$I$  is the same (at all points ) 1

(probably)  $n$  (and  $Q$ ) is the same in both wires 1

[8]

112. Resistance of films

$$R = \frac{\rho l}{A} \quad 1$$

$$R = \frac{\rho l}{\omega t} \text{ or } A = \omega t \text{ [consequent on first mark]} \quad 1$$

[i.e. product =  $\omega t$ ]

Resistance calculation

$$R = \frac{(6.0 \times 10^{-5} \Omega \text{m}) \times (8 \times 10^{-3})}{(3 \times 10^{-3} \text{ m}) \times (0.001 \times 10^{-3} \text{ m})}$$

OR

$$R = \frac{(6.0 \times 10^{-5} \Omega \text{m}) \times (8 \text{ mm})}{(3.0 \text{ mm})(1.0 \times 10^{-6} \text{ m})}$$

$$R = 160 \Omega$$

Correct substitution except powers of 10 1

Correct powers of 10 1

Answer 1

Resistance of square film

$$l = \omega \quad 1$$

$$R = \frac{\rho}{t} \quad 1$$

**[7]**

113. Definition of specific heat capacity

Energy (needed) 1

(per) unit mass/kg ) 1

(per) unit temperature change/ °C / K )

OR

Correct formula [does not need to be rearranged] 1

with correctly defined symbols 1

Circuit diagrams

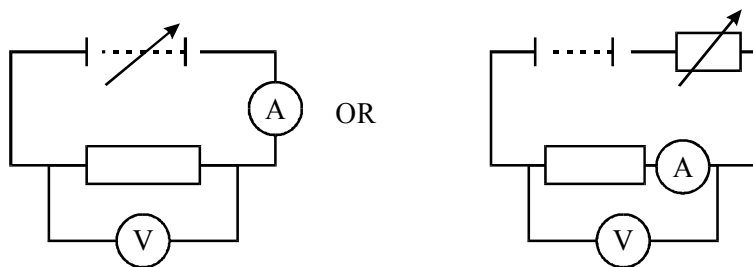

Accept voltmeter across heater and ammeter as well as voltmeter across heater only

Means of varying p.d./current 1

Voltmeter in parallel with a resistor symbol 1

Ammeter in series with any representation of heater 1

Other apparatus

• (Top pan) balance / scales 1

• Stopwatch / timer / clock 1

Explanation

Energy/heat loss to surroundings/air/bench

OR

$mc\Delta\theta + \Delta Q = VIt$  or equivalent in words (e.g. student ignores energy loss in calculations)

OR

$mc\Delta T + \Delta Q = VIt$  or equivalent words 1

Modifications

Any two from

- Use of insulation around block
- Ensure all of heater is within block
- Grease heater/thermometer 2

**[10]**

**114.** Specific heat capacity calculation

$$c = \frac{\Delta Q}{m\Delta\theta} = \frac{860 \times 10^3 \text{ J}}{1.4 \text{ kg} \times (750 - 22) \text{ }^\circ\text{C}}$$

$$c = 844 \text{ (J kg}^{-1} \text{ K}^{-1}/^\circ\text{C}^{-1}\text{)}$$

Conversion to joule  $\times 10^3$  1

Subtraction of temperature 1

Answer 1

Energy transfers (diagram)

- Label 2 (energy to) (warm) water (and trough) 1
- Label 3 (energy used to) evaporate water/cause evaporation/latent heat/change in state 1

[5]

115. Gas equation

$PV = nRT$  [Accept symbols or words] 1

Molar gas constant unit

$$R = \frac{PV}{nT}$$

$P - \text{kg m}^{-1} \text{s}^{-2}$  1

$V - \text{m}^3$  )  
 $T - \text{K}$  ) 1  
 $n - \text{mol}$  )

Kinetic energy of molecule

$Nm = M$

$\rho = \frac{Nm}{3V} \langle c^2 \rangle$  correctly combined the 2 equations 1

$Nm \langle c^2 \rangle = 3nRT$  density = any mass ÷ volume 1

Show that

Kinetic energy =  $\frac{m \langle c^2 \rangle}{2} = \frac{3}{2} n \frac{RT}{N}$  1

Sketch graph

$PV$  on y axis )  
Temperature/°C on x axis ) 1

[accept axes reversed and correct graph]  
Straight line graph with negative intercept 1

Gradient  $R$  1

Intercept at  $-273^\circ\text{C}$  1

[All these marks can be scored on graph]

[10]

116. Definition of e.m.f. of a cell

Work/energy (conversion) per unit charge 1

for the whole circuit / refer to total (energy) 1

OR

Work/energy per unit charge 1

converted from chemical to electrical (energy) 1

OR

$$E = \frac{W}{Q} \text{ for whole circuit} \quad 1$$

All symbols defined 1

OR

$$E = \frac{P}{I} \text{ for whole circuit} \quad 1$$

All symbols defined 1

[Terminal p.d. when no current drawn scores 1 mark only]

Circuit diagram

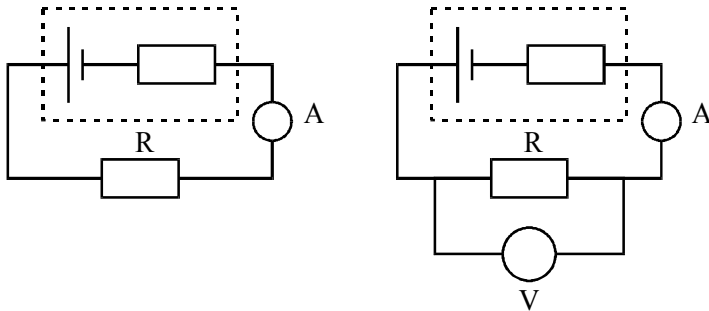

R	1	R (can be variable)	1	2
A in series	1	A and V correct	1	
		V as shown		
		Or across R + A		
		Or across battery		

[2<sup>nd</sup> mark is consequent on R(fixed, variable) or lamp]

Sketch graph

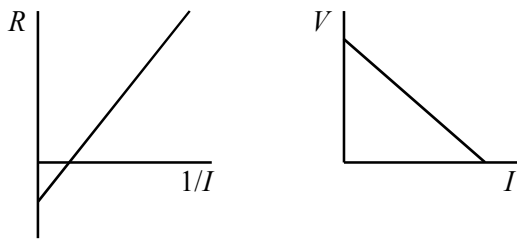

Graph correctly drawn with axes appropriately labelled and consistent with circuit drawn 1

Intercept on R axes  $\equiv (-)r$  Gradient  $\equiv (-)r$  [Gradient mark consequent on graph mark] 1

[Gradient may be indicated on graph]

**[6]**

**117. Resistance calculations**

Evidence of  $20 \Omega$  for one arm **(1)**

$$\frac{1}{R} = \frac{1}{20} + \frac{1}{20} \quad \mathbf{(1)}$$

$R = 10 \Omega$  **(1)** 3

Comment

This combination used instead of a single  $10\ \Omega$  resistor [or same value as before] (1)

because a smaller current flows through each resistor/reduce heating in any one resistor/average out errors in individual resistors (1)

2

[5]

**118. Graphs**

Diode:

RH quadrant: any curve through origin (1)

Graph correct relative to labelled axes (1)

LH side: any horizontal line close to axes (1)

3

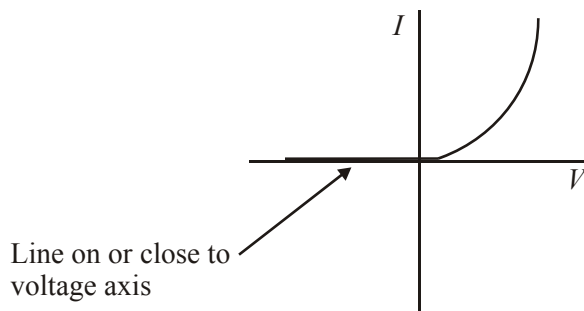

Filament lamp

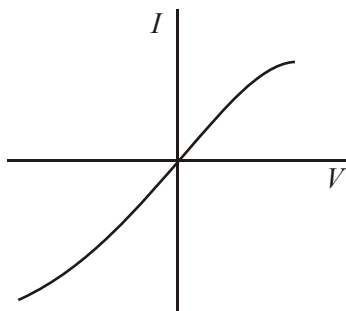

RH quadrant:

Any curve through origin (1)

Curve correct relative to axes (1)

LH quadrant:

Curve correct relative to RH quadrant (1)

[Ohmic conductor scores 0/3]

3

[6]

**119. Circuit**

Ammeters and two resistors in series (1)

[1 mark circuit penalty for line through cell or resistor]

1

Cell e.m.f

$E = 150 \times 10^{-6} \text{ (A)} \times 40 \times 10^3 \text{ (}\Omega\text{)}$  total  $R$  (1)

Powers of 10 (1)

2

$E = 6.0 \text{ (V)}$

New circuit

Voltmeter in parallel with 25 (kΩ) resistor (1)

1

Resistance of voltmeter

$$(\text{Total resistance}) = \frac{6(\text{V})}{170 \times 10^{-6}(\text{A})}$$

$$= (35.3 \text{ k}\Omega) \quad (1)$$

$$\begin{aligned} (\text{Resistance of ll combination}) &= 35 - 15 \text{ k}\Omega \\ &= (20 \Omega) \text{ [e.c.f. their total resistance]} \end{aligned} \quad (1)$$

$$\frac{1}{20} = \frac{1}{25} + \frac{1}{R_V}$$

$$\frac{1}{R_V} = \frac{5 - 4}{100}$$

$$R_V = 100 \text{ k}\Omega \text{ [108 k}\Omega \text{ if } R_T \text{ calculated correctly]} \quad (1)$$

**Alternative route 1:**

3

$$\text{p.d. across } 15 \text{ k}\Omega = 2.55 \text{ V} \quad (1)$$

(∴ p.d. across ll combination = 3.45 V)

resistance combination = 20 kΩ

$$\rightarrow R_V = 100 \text{ k}\Omega \quad (1)$$

$$\rightarrow R_V = 100 \text{ k}\Omega \quad (1)$$

[7]

**Alternative route 2:**

3

$$\text{p.d. across parallel combination} = 3.45 \text{ V} \quad (1)$$

$$I \text{ through } 25 \text{ k}\Omega = 138 \mu\text{A} \quad (1)$$

$$\rightarrow R_V = 100 \text{ k}\Omega \quad (1)$$

**120. Resistance of strain gauge**

$$\text{State } R = \frac{\rho l}{A} \quad (1)$$

Use of formula (1)

x 6 (1)

$$R = 0.13 \Omega \text{ [ecf their } l] \quad (1)$$

4



$$\left( \begin{array}{l} R = \frac{\rho l}{A} = \frac{9.9 \times 10^{-8} \Omega \text{m} \times 2.4 \times 10^{-2} \text{m} \times 6}{1.1 \times 10^{-7} \text{m}^2} \\ = 129.6 \times 10^{-3} \Omega \\ R = 0.13 \Omega \end{array} \right)$$

Change in resistance

$$\Delta R = 0.13 \Omega \times 0.001$$

$$\Delta R = 1.3 \times 10^{-4} (\Omega) \text{ [no e.c.f.]}$$

OR

$$\Delta R = 0.02 \times 0.001$$

$$\Delta R = 2.0 \times 10^{-5} \Omega$$

$$0.1\% \rightarrow 0.001 \text{ (1)}$$

Correct number for  $\Delta R$  (1)

2

Drift velocity

Stretching causes  $R$  to increase (1)

Any two from:

- Current will decrease
- $I = nAvQ$
- Drift velocity  $v$  decreases
- $nAe$  constant (1) (1)

3

[9]

[For  $R$  decreasing, max 1:

Any one from:

- $I$  will increase
- $I = nAvQ$
- $v$  will increase
- $nAe$  constant]

**121. Relationship**

Interpretation of line passing through origin i.e. direct proportionality OR inverse proportionality (1)

between appropriate quantities (1)

2

[Comment that: as  $p \uparrow$ ,  $V \downarrow$  / as  $p \uparrow$ ,  $1/V \downarrow$  /  $p$  times  $V$  is constant, scores 1 mark only]

Sketch graph

A line with negative gradient (1)

Concave curve [must not touch either axis or continue parallel to axes] (1)

2

Units of  $pV$

$$\text{Nm}^{-2} \times \text{m}^3 \text{ [or correct more complex version] (1)}$$

$$\text{Nm} = \text{J (1)}$$

2

Explanation

Quality of written communication (1)

1

Any four from the following:

- molecules collide with walls of container
- molecules undergo a change of direction/momentum
- force is rate of change of momentum

- pressure =  $\frac{\text{force}}{\text{area}}$  (1) (1) (1)

- large number of molecules hence pressure same/constant (1)

Max 4

[11]

122. Value of R

$$\left( \begin{array}{l} \text{Gradient} = \frac{(0.95 - 0.70) \times 10^5 \text{ Pa}}{380 - 280\text{K}} = 0.25 \times 10^3 \text{ PaK}^{-1} \\ R = \frac{\text{their gradient}/0.25 \times 10^3 \text{ PaK}^{-1} \times V}{n} \\ = \frac{0.25 \times 10^3 \text{ PaK}^{-1} \times 0.016\text{m}^3}{0.50 \text{ mol}} \\ R = 8.0 \text{ JK}^{-1} \text{ mol}^{-1} \end{array} \right)$$

[Work back]

Attempt to find the gradient or see  $0.25 \times 10^3$  (1)

Substitution of 0.016 and 0.50 (1)

$$R = 8.0 \text{ J K}^{-1} \text{ mol}^{-1} \text{ (1)}$$

3

Addition to graph

Straight line, positive gradient (1)

Line starts at  $0.35 \times 10^5 \text{ Pa}$

Line has half gradient / finishes at  $0.475 \times 10^5 \text{ Pa}$  (1)

3

[6]

123. Diagram

To include

- lagging
- clock or top pan balance
- variable supply/rheostat + supply OR joulemeter + supply
- V and A correct OR joulemeter parallel to supply (1) (1) (1)

Max 3

Measurements

Mass of aluminium ( $m$ ) (1)

Initial and final temperature ( $\theta_1, \theta_2$ ) (1) 2

EITHER

Current ( $I$ ) and p.d. ( $V$ ) (1)

Time ( $t$ ) that current flows (1)

OR

Initial joulemeter reading (1)

Final joulemeter reading (1) 2

Use of measurements

EITHER

Find temperature rise

Rearranged equation  $C = \frac{VI t}{m\Delta\theta}$  OR equivalent (1)

OR

Plot graph  $\theta \rightarrow t$  (1)

$$C = \frac{VI}{m \text{ gradient}} \quad (1)$$

Any one assumption (1)

Assume no heat losses to surroundings OR heater completely within block

OR heater 100% efficient

OR Good thermal contact between heater and block OR temperature of block uniform throughout OR stop/start time of clock and heater are the same

[10]

<b>124.</b>	<u>Advantage of log splitter</u>		
	Effort < load/force multiplier <b>(1)</b>		1
	<u>Pressure</u>		
	$p = \frac{1.7 \times 10^6 \text{ N}}{7.8 \times 10^{-3} \text{ m}^2}$		
	$= 0.22 \times 10^9$		
	$p = 2.2 \times 10^8 \text{ Pa} \text{ (} 2.17 \times 10^8 \text{ Pa)}$		
	Substitute in $p = F/A$ look for 1.7 and 7.8 [ignore $10^x$ ] <b>(1)</b>		
	Answer <b>(1)</b>		2
	<u>Assumption</u>		
	Pressure is same throughout the liquid/oil		
	OR		
	Oil is incompressible		
	OR		
	Pressure exerted by pump is transmitted by oil to piston		
	OR		
	No friction between piston and cylinder <b>(1)</b>		1
	<u>Power output</u>		
	$\text{Power} = \frac{1.7 \times 10^6 \text{ N} \times 0.60 \text{ m}}{20 \text{ s}}$		
	$\text{Power} = 5.1 \times 10^4 \text{ W} \text{ (} 51 \text{ kW)}$		
	Appropriate substitution [ignore $10^x$ ] <b>(1)</b>		
	Answer <b>(1)</b>		2
			<b>[6]</b>
<b>125.</b>	<u>Charge</u>		
	Charge is the <u>current <math>\times</math> time</u> <b>(1)</b>		1
	<u>Potential difference</u>		
	Work done per unit charge [flowing] <b>(1)</b>		1
	<u>Energy</u>		
	$9 \text{ V} \times 20 \text{ C} \text{ (1)}$		
	$= 180 \text{ J} \text{ (1)}$		2
			<b>[4]</b>
<b>126.</b>	<u>Number of electrons</u>		
	$(-64 \times 10^{-9} \text{ C}) / (-1.6 \times 10^{-19} \text{ C}) = 4.0 \times 10^{11} \text{ electrons}$		
	Use of $n = Q/e$ <b>(1)</b>		
	Seeing $1.6 \times 10^{-19} \text{ C}$ <b>(1)</b>		
	Answer of $4.0 \times 10^{11}$ (electrons) <b>(1)</b>		3
	[Use of a unit is a ue]		
	[-ve answer: 2/3]		

Rate of flow

$(6.4 \times 10^{-8} \text{ C})/3.8 \text{ s} = 16.8/17 [\text{nC s}^{-1}] \text{ OR } 16.8/17 \times 10^{-9} [\text{C s}^{-1}]$

$(6.4) / 3.8 \text{ s i.e. use of } I = Q/t \text{ [Ignore powers of 10] (1)}$

Correct answer [No e.c.f.]  $[1.7 \text{ or } 1.68 \times 10^{-8} \text{ or } 1.6 \times 10^{-8}] \text{ (1)}$  2

Unit

Amp(ere)/A (1) 1

[6]

**127. Rate of absorption**

Rate =  $(0.24 \text{ kg s}^{-1}) \times (4200 \text{ J kg}^{-1} \text{ K}^{-1}) \times (2.0 \text{ K})$

=  $2016 \text{ J s}^{-1} / \text{W}$  or  $2.0 \text{ kW}$

Use of  $\Delta Q/\Delta t = (\Delta m/\Delta t)c\Delta T \text{ (1)}$

See use of  $2 \text{ K}/2 \text{ }^\circ\text{C} \text{ (1)}$

Answer (1) 3

1<sup>st</sup> law: statement and explanation of value for each

$\Delta U = 0 \text{ (J) (1)}$

Coil is at a constant temperature (1)

$\Delta Q = -2016/2020/2000 \text{ J}$  [e.c.f. their value from calculation above, not 350 J] (1)  
as this is the energy (the coil supplies) to the water (1)

Consistent answer with their values of  $\Delta U$  and  $\Delta Q$  (1)  
so that energy is conserved OR  $0 = 2000 \text{ J} - 2000 \text{ J}$  since

$\Delta U = \Delta Q + \Delta W \text{ (1)}$  6

[9]

**128. Homogeneity of equation  $\Delta p = h\rho g$**

LHS units  $\text{kg m}^{-1} \text{ s}^{-2} \text{ (1)}$

RHS units  $\Delta h \quad \text{m}$   
 $g \quad \text{m s}^{-2} \text{ (1)}$

$\rho \quad \text{kg m}^{-3} \text{ (1)}$  3

[OR LHS  $\text{N m}^{-2}$ ; RHS  $\Delta h - \text{m}, g - \text{N kg}^{-1}, \rho - \text{kg m}^{-3}$ ]

Calculation

Pressure due to liquid:

=  $30 \text{ m} \times 1170 \text{ kg m}^{-3} \times 9.8 \text{ m s}^{-2} \text{ (1)}$

=  $343 \text{ 980} / 344 \text{ 331 Pa} \text{ (1)}$

Use of  $P_1 V_1 = P_2 V_2 \text{ (1)}$

[ecf their pressure value]

$(343 \text{ 980 Pa} + 101 \text{ 000 Pa}) \times 2 \text{ cm}^3 = 101 \text{ 000 Pa} \times V \text{ (1)}$

[Addition of air pressure]

$V = 8.82 \text{ cm}^3 \text{ [Accept } 8.8 \text{ cm}^3 \text{ min 2 sf] (1)}$  4

[Candidates who do not add ap  $\rightarrow V = 6.81 \text{ cm}^3$ , score 2/4]

[7]

**129. Definition of specific latent heat of vaporisation**

The energy( per) unit mass /kg **(1)**  
 needed to change the state from liquid to vapour [accept water to steam] **(1)**  
 at its boiling point/at 100 °C/at a constant temperature **(1)** 3

Energy  
 Uses product Pt or  $240 \text{ W} \times 285 \text{ s}$  **(1)**  
 Energy = 68 400 J/68 000 J **(1)** 2

Value of  $l_v$   
 $(68\,400 \text{ J}) / (301 - 265) \times 10^{-3} \text{ kg}$   
 $= 1.9 \times 10^6 \text{ (J kg}^{-1}\text{)}$  [Units not required]  
 ecf energy values that round to 2

Conversion of g to kg/converts units of final answer **(1)**  
 See “1.9” (1.9/1.88) **(1)** 2

Suggestion and explanation  
 Quality of written communication **(1)** 1

$L_v$ , increases **(1)**

$\Delta m$  smaller **(1)**

same time/ same Q/ same energy **(1)**

OR

$L_v$ , increases **(1)**

t greater **(1)**

so Q greater (consequent mark) **(1)** 3

[ $l_v$ , decreases or stays same 0/3]

**[11]**

**130.** Explanation of observation

Any two from:

- LED on reverse bias/R in LED infinite/ LED wrong way round
- so current is zero /LED does not conduct / very small reverse bias current
- since  $V = IR$
- $V = 0 \times 1\text{K} = 0 \text{ V}$  **(1) (1)** 2

Explanation of dimness

$R_V$  very large /  $R_V$  much greater than  $R_{LED}$  **(1)**

Current very low / pd across LED very small (not zero) **(1)** 2

Circuit diagram

LED in forward bias **(1)**

Variation of pd across LED **(1)**

Voltmeter in parallel with LED alone **(1)** 3

[LED in series with voltmeter 0/3]

**[7]**

**131.** Circuit diagram

Ammeter in series with cell and variable resistor (correct symbol) **(1)**

Voltmeter in parallel with cell OR variable resistor **(1)** 2

Power output at point X

Power = voltage  $\times$  current **(1)**

$$= 0.45 \text{ V} \times 0.6 \text{ A}$$

$$= 0.27 \text{ W} \text{ (1)}$$

2

Description of power output

Any three from:

- Current zero; power output zero/small/low
- As current increases power output also increases
- Then (after X ) power decreases
- Maximum current; power output zero **(1) (1) (1)**

3

[Accept reverse order]

e.m.f. of cell

$$0.58 \text{ V} \text{ (1)}$$

1

Internal resistance

Attempt to use  $\frac{\text{"lost volts"}}{\text{current}}$  OR  $\mathcal{E} = V + IR$  **(1)**

$$= \frac{0.58\text{V} - 0.45\text{V}}{0.6\text{A}}$$

$$= 0.217 / 0.2 \Omega \text{ (1)}$$

2

[ecf an emf greater than 0.45 V]

**[10]**

**132. Statement 1**

Statement is false **(1)**

Wires in series have same current **(1)**

Use of  $I = nAev$  with  $n$  and  $e$  constant **(1)**

3

[The latter two marks are independent]

Statement 2

Statement is true **(1)**

Resistors in parallel have same p.d. **(1)**

Use of Power =  $V^2/R$  leading to  $R \uparrow$ , power  $\downarrow$  **(1)**

3

OR as  $R \uparrow$ ,  $I \downarrow$  leading to a lower value of  $VI$  3<sup>rd</sup> mark consequent on second

**[6]**

133. Temperature calculation

Current =  $4.5 \times 10^{-3}$  A (1)

p.d. across thermistor is 4.2 V (1)

$R_{\text{thermistor}} = 930 \Omega$  ecf their current and pd subtraction error (1)

Temperature =  $32^\circ\text{C} - 34^\circ\text{C}$  [Allow ecf for accurate reading] (1) 4

Supply doubled

Any two from:

- Current would increase / thermistor warms up / temperature increases
- Resistance of thermistor would decrease (1) (1)
- Ratio of p.d.s would change

No OR voltmeter reading / pd across R more than doubles (1) 3

[This mark only awarded if one of the previous two is also given]

[7]

134. Definition

L energy per unit mass OR formula with defined symbols (1)

During (change of state) / solid to liquid / liquid to solid (1)

At a constant temperature (1) 3

Description of graph

AB: Cooling (liquid) / temperature decreasing / energy lost (1)

BC: Change (in state) from liquid to solid (1)

At constant temperature / at  $80^\circ\text{C}$  (1)

CD: Cooling / loss of energy / temp decrease of solid (1) 4

Energy calculation

Correct use of  $\Delta Q = mc\Delta\theta$  (1)

21 000 J (1) 2

SLH calculation

$106\,000\text{ J} - 21\,000\text{ J} = 85\,000\text{ J}$  [ecf their value] (1)

Correct use of energy =  $Lm$  (1)

$170\,000\text{ J kg}^{-1}$  (1) 3

[12]



135. Diagram

Labelled wire and a supply (1)

Ammeter in series and voltmeter in parallel (1)

OR

Labelled wire with no supply (1)

Ohmmeter across wire (1)

2

Readings

Current and potential difference OR resistance (consistent with diagram) (1)

Length of wire (1)

Diameter of wire (1)

3

Use of readings

$R = V/I$  OR  $\rho = RA/l$  (1)

Awareness that A is cross-sectional area (may be seen above and credited here) (1)

Repetition of calculation OR graphical method (1)

3

Precaution

Any two from:

- Readings of diameter at various places /different orientations
- Contact errors
- Zeroing instruments
- Wire straight when measuring length
- Wire not heating up / temperature kept constant (1) (1)

2

[10]

136. Hydraulic systems – forces

Any three from:

- Liquid transmits (same) pressure
- The area of the piston where the pressure is created is much less than the area where the pressure acts
- Pressure = Force ÷ area / Force = pressure × area
- Increasing the area leads to an increased force (1) (1) (1)

Quality of written communication (1)

[4]

137. Thermal energy

Conversion of g to kg (1)

Power =  $mc\Delta\theta/t$  [there must be some reference to time] (1)

Answer = 9450 W [9.45 kW] (1)

[Accept reverse calculation Answer =  $7.2 \times 10^{-2}$  (kg)] (1)

3

Current calculation

Correct use of $I = P/V$ (1)	
$I = 39 \text{ A}$ (1)	2
<u>Conductor resistance</u>	
$R = \rho l/A$ (1)	
Correct substitution of data (1)	
$R = 4.3 \times 10^{-2} \Omega$ (1)	3
<u>Manufacturer's recommendation</u>	
Larger $A$ has a lower $R$ (1)	
Energy loss depends on $I^2 R$ / reduces overheating in wires (1)	2

[10]

138. Car battery

Voltmeter reading: 12.2 (V) (1)	1
<u>Equation</u>	
Terminal p.d. = 12 V + (5.0 A $\times$ 0.04 $\Omega$ )	
See 12V (1)	
See 5.0 A $\times$ 0.04 $\Omega$ (1)	
Addition of terms (1)	3
<u>Wasted power</u>	
See 0.04 $\Omega$ + 0.56 $\Omega$ OR 2.8 V + 0.2 V OR 5 x (15 – 12) W (1)	
Power = 15 W (1)	2
<u>Efficiency</u>	
(same current) 12 V / 15 V OR $P_{\text{OUT}}/P_{\text{IN}} = 60 \text{ W}/75 \text{ W}$ (1)	
Efficiency = 0.8/80%      Efficiency = 0.8/80% (1)	2
<u>Explanation</u>	
Any two from:	
• Starter motor / to start car needs (very) large current	
• $I = \frac{E}{R + r}$	
• ( $E$ and $R$ fixed) $r_{\text{min}} \Rightarrow I_{\text{max}}$ (1) (1) (1)	2

[10]

**139. Mean square speed**

Attempt to find either squares or any mean **(1)**

See  $2.8 \times 10^5$  (278 300) **(1)**

Units:  $\text{m}^2 \text{s}^{-2}$  or  $(\text{m s}^{-1})^2$  **(1)**

3

Expression

$$(\rho =) \frac{Nm}{V}$$

1

Average kinetic energy

Substitution of  $\frac{Nm}{V}$  for  $\rho$  **(1)**

State kinetic energy =  $\frac{1}{2} m \langle c^2 \rangle$  **(1)**

Equate  $nRT = \frac{1}{3} Nm \langle c^2 \rangle$  [ie makes a correct substitution for pV] **(1)**

States  $\frac{n}{N}R$  OR  $n$ ,  $N$  and  $R$  constant (so  $ke \propto T$ ) **(1)**

Max 3

**[7]**

**140. (a) Show that energy stored can be written as in formula**

$W = \frac{1}{2} Fx$  [allow  $x$  or  $\Delta x$ ] **(1)**

$F = kx$  **(1)**

2

Graph

Rising curve [either shape] **(1)**

starts at origin and correct shape, i.e. gets steeper **(1)**

2

- (b) Young modulus of copper  
 Read valid pair off straight line region **(1)**  
 1.3 [when rounded to 2 s.f.] **(1)**  
 correct power of 10, i.e.  $\times 10^{11}$  **(1)**  
 Correct unit: Pa OR  $\text{N m}^{-2}$  4  
Copper wire  
 Obtain reasonable extension/reduce uncertainty **(1)** 1  
Calculation of stress  
 Use of  $\pi r^2$  **(1)**  
 Substitution in  $F/A$  i.e. allow 280 N/r [OR their  $A$ ] **(1)**  
 $1.8 \times 10^8$  Pa [No e.c.f.] **(1)** 3  
Point P  
 Point P marked on graph [e.c.f.] 1  
Justification  
 Behaviour is elastic since on straight line region [e.c.f.] 1
- (c) Explanation of edge dislocation  
 Acceptable 2-D diagram **(1)**
- 
- with incomplete layer/row/plane of atoms, labelled **(1)** 2
- How presence of dislocations can reduce cracking  
 Quality of written communication **(1)**
- high stress (concentrations) at (tip of) crack **(1)**
  - plastic flow occurs/ dislocations move **(1)**
  - blunts tip of crack/relieves stress at tip of crack/prevents crack propagation **(1)** 4
- (d) Descriptions  
 HDPE melts **(1)**  
 Melamine burns/decomposes **(1)**  
 Perspex softens/can be moulded **(1)** 3  
Typical use  
 HDPE: buckets/washing-up bowls/pipes/bottles **(1)**  
 Melamine: work tops/light fittings **(1)**  
 Perspex: windows/car parts/boxes/models/teeth **(1)**

- (e) Difference between annealing and quench-hardening  
 Annealing: heat and cool slowly (1)  
 Quenching: heat and cool quickly (1) 2  
Suggestion  
 Tools, gear wheels, weapons, etc. (1) 1
- (f) Why pre-stressed reinforced beam is more appropriate  
 Concrete is weak in tension/could crack when loaded (1)  
 Pre-stressed reinforce concrete contains steel (iron) rods/cables  
 [not beams or bars] (1)  
 Rods in tension/hold concrete in compression (1) 3

[32]

141. Circuits

- Base unit: ampere OR amperes OR amp OR amps (1)  
 Derived quantity: charge OR resistance (1)  
 Derived unit: volt OR volts OR ohm OR ohms (1)  
 Base quantity: current (1) 4

[If two answers are given to any of the above, both must be correct to gain the mark]

[4]

142. (a) Io and Jupiter: Time taken for electrons to reach Jupiter  
 $t = s/v = (4.2 \times 10^8 \text{ m}) / (2.9 \times 10^7 \text{ m s}^{-1}) = 14.48 \text{ s}$   
 Correct substitution in  $v = s/t$  (ignore powers of ten) (1)  
 Answer: 14.48 s, 14.5 s [no ue] (1) 2
- (b) Estimate of number of electrons  
 $Q = ne = It$   
 $n = It/e$   
 $n = (3.0 \times 10^6 \text{ A}) (1\text{s}) / (1.6 \times 10^{-19} \text{ C})$   
 Use of  $ne = It$  (1)  
 $(1.8 - 2.0) \times 10^{25}$  (1) 2
- (c) Current direction  
 From Jupiter (to Io) / to Io / to the moon (1) 1

[5]

143. (a) p.d. across 4 Ω resistor  
 $1.5 \text{ (A)} \times 4 \text{ (}\Omega\text{)}$   
 $= 6 \text{ V (1)}$  1

- (b) Resistance  $R_2$   
 Current through  $R_2 = 0.5 \text{ A}$  (1)  

$$R_2 = \frac{6(\text{V})}{0.5(\text{A})}$$

$$R_2 = 12 \Omega$$
 (1) 2  
 [allow ecf their pd across  $4 \Omega$ ]
- (c) Resistance  $R_1$   
 p.d. across  $R_1 = 12 - 6 - 4$   
 $= 2 \text{ V}$  (1)  
 Current through  $R_1 = 2 \text{ A}$  (1)  

$$R_1 = \frac{2(\text{V})}{2(\text{A})} = 1 \Omega$$
 (1)  
 [allow ecf of pd from (a) if less than  $12 \text{ V}$ ]  
 Alternative method  
 Parallel combination =  $3 \Omega$  (1)  
 Circuit resistance =  $12(\text{V})/2 (\text{A}) = 6 \Omega$  (1)  
 $R_1 = 6 - (3 + 2) = 1 \Omega$  (1) 3  
 [allow ecf of pd from (a) and R from (b)]

[6]

144. (a) Current in filament lamp  
 $P = VI$  or correct rearrangement (1)  
 $2 \text{ A}$  (1) 2
- (b) (i) Sketch graph  
 Correct shape for their axes (1)  
 $-I-V$  quadrant showing fair rotational symmetry (1) 2

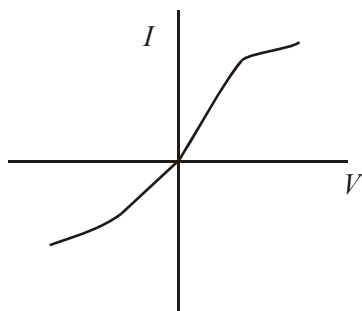

- (ii) Explanation of shape  
 (As the voltage/p.d. increases), current also increases **(1)**  
 (As the current increases), temperature of lamp increases **(1)**  
 (This leads to) an increase in resistance of lamp **(1)**  
 so equal increases in  $V$  lead to smaller increases in  $I$  OR rate of increase in current decreases OR correct reference to their correct **(1)** 4  
 gradient

**[8]**

[If a straight line graph was drawn though the origin then **(1)(0)(0)(1)** for the following:

$V$  is proportional to  $R$   
 therefore the graph has a constant gradient]

145. (a) (i) Graph  
 Attempt to find gradient at start of graph ie over  $11^{\circ}\text{C}$  rise or less **(1)**  
 Value calculated with units in  $\text{K s}^{-1} / \text{K min}^{-1} / ^{\circ}\text{C s}^{-1} / ^{\circ}\text{C min}^{-1}$   
 Range  $0.07 - 0.18 \text{ K s}^{-1}$  or  $4.4 - 11.0 \text{ K min}^{-1}$  **(1)** 2
- (ii) Power of heater  
 Formula  $\Delta Q/\Delta t = mc\Delta T/\Delta t$  used **(1)**  
 Converts g to kg **(1)**  
 Value for rate within acceptable range  $18 - 50 \text{ W}$  **(1)** 3  
 or  $1100 - 3000 \text{ J min}^{-1}$   
 [no ecf from gradient]
- (b) Heating process  
 (rate of) energy lost to the surroundings OR due to evaporation[do **(1)**  
 not credit boiling] **(1)** 2  
 approaches (rate of ) energy supply OR increases with temperature difference.
- (c) Graph  
 (i) Curve of reducing gradient starting at  $20^{\circ}\text{C}$ ,  $0 \text{ s}$  **(1)**  
 initially below given graph (consequential mark) **(1)** 2
- (ii) Explanation  
 Reference of need to heat mug **(1)**  
 Hence reduced rate of temperature rise [consequential mark] **(1)**  
 Reference to insulating properties of mug **(1)** Max 2



**[11]**

146. (a) (i) Definition of quantities
- $n$       number of moles (1)  
 $R$       molar gas constant (1)      2
- (ii) Meaning of the temperature absolute zero  
 Temperature at which pressure [or volume] of a gas is zero  
 OR  
 temperature at which kinetic energy of molecules is zero (1)      1
- (b) Number of moles of gas  
 Use of  $pV = nRT$  (1)  

$$n = \frac{1.1 \times 10^5 (\text{Pa}) \times 60(\text{m}^3)}{8.31(\text{JK}^{-1}\text{mol}^{-1})298(\text{K})}$$

$$= 2665 \text{ moles}$$
 Conversion to kelvin (1)  
 Answer (1)      3

[6]

147. (a) (i) Replacement  
 $V_1$  (1)      1
- (ii) Explanation  
 [ONE pair of marks]  
 Resistance: resistance of  $V_1$  [not just the voltmeter] is much larger than  $100 \Omega$  OR combined resistance of parallel combination is (1) approximately  $100 \Omega$   
 Voltage: p.d. across  $V_1$  is much greater than p.d. across  $100 \Omega$  OR (1) all  $9 \text{ V}$  is across  $V_1$   
 OR  
 Current: no current is flowing in the circuit / very small current (1)  
 Resistance: because  $V_1$  has infinite/very large resistance (1)  
 OR  
 (Correct current calculation  $0.9 \times 10^{-6} \text{ A}$  and) correct pd calculation  $90 \times 10^{-6} \text{ A}$  (1)  
 This is a very small/negligible pd (1)      2
- (b) Circuit diagram
- (i)  or equivalent resistor symbol labelled  $10 \text{ M}\Omega$  (1)  
 or equivalent resistor symbol labelled  $10 \text{ M}\Omega$  (1)      2
- [They must be shown in a correct arrangement with R]



(ii) Value of R

6 (V): 3 (V) = 10 (MΩ): 5 (MΩ) /  $R_{\text{total}}$  of parallel combination is 5 (1)  
MΩ

$1/5 \text{ (M}\Omega) = 1/10 \text{ (M}\Omega) + 1/R$  OR some equivalent correct (1)  
substitution to show working

$R = 10 \text{ M}\Omega$  (1)

3

[8]

148. (a) Terms in efficiency equation

$T_1$ : temperature of hot reservoir/hot source (1)

$T_2$ : temperature of cold reservoir/cold sink (1)

Reference to kelvins/absolute (1)

Max 2

(b) (i) Calculation of initial temperature

$$E = 1 - \frac{T_2}{T_1}$$

$$\frac{T_2}{T_1} = 1 - E = 1 - 0.53$$

$$T_1 = \frac{373(K)}{0.47}$$

$$T_1 = 794 \text{ K} / 521 \text{ }^\circ\text{C}$$

Substitution into equation [no rearranging] E and  $T_1$  ignore powers (1)  
of 10

Use of 373 K (1)

Answer (1)

3

(ii) Improvement of efficiency of power station

Increase value of  $T_1$  / reduce value of  $T_2$  / increase temperature (1)  
difference

1

[ecf their terms for  $T_1 / T_2$ ]

[6]

149. (a) Smoke particles

Smoke particles/bright specks moving randomly/irregularly (1)

[Ensure it is *not* air]

Motion is due to collisions with air molecules / gas molecules (1)

Any one further comment from:

- air molecules cannot be seen / invisible
- uneven collisions produce / resultant force produced
- air molecules have high speed (in order to be able to move heavier smoke particles) (1)

Quality of written communication (1)

4

- (b) Diagram  
 Path that has  
 different length straight sections (min of 5) (1)  
 different directions (1)



2

[6]

150. (a) (i) Lamp brightness

Lamp A (1)

Larger current through it (at 9.0 V)/greater power (1)  
 (at 9.0 V)/smaller resistance (at 9.0 V)

2

- (ii) Battery current

Addition of currents (1)

Current = 1.88 – 1.92 A (1)

2

- (iii) Total resistance

$R = 9 \text{ V}/1.9 \text{ A}$  or use of parallel formula (1)

$R = 4.6 - 4.9 \Omega$  (1)

2

[full ecf for their current]

- (b) Lamps in series

Current same in both lamps/current in A reduced from original value (1)

Pd across A less than pd across B (1)

Lamp A has a lower resistance than lamp B (1)

$P = VI$  or  $P = RI^2$  (1)

Any 2

Lamp A will be dimmer than B [conditional on scoring ONE of (1)  
 the above marks]

1

[9]

151. (a) (i) Resistance

Use of  $V/I$  [ignore  $10^x$ ] (1)

3800  $\Omega$  (3784  $\Omega$ ) (1)

2

- (ii) Resistance of thermistor

Use  $\frac{V_R}{V_{TH}} = \frac{R}{R_{TH}}$  OR  $9\text{V}/.74\text{mA} = R$  OR (1)

$6.2 \text{ V} = 0.74 \text{ mA} \times R_{TH}$

8400  $\Omega$  [8378  $\Omega$ ] [substituting 4000  $\Omega$  gives 8857  $\Omega$  ie 8900  $\Omega$ ] (1)

[method 2 substituting 3800  $\Omega$  gives 8362  $\Omega$ : substituting 4000  $\Omega$   
 gives 8162  $\Omega$ ]

2

- (b) Suggestion and Explanation  
 The milliammeter reading increases (1)  
 Thermistor resistance ‘becomes zero’ /Short circuit (1)  
 Since supply voltage is constant /  $I = 9.0 V/R$  (1)  
 OR  
 Circuit resistance reduced 3 [7]

152. (a) Definition of E.M.F.  
 Energy (conversion) or work done (1)  
 Per unit charge (1)  
 OR  
 $E = W/Q$  (1)  
 Symbols defined (1)  
 [E = 1J/C scores 1]  
 OR  
 $E = P/I$  (1)  
 Symbols defined (1)  
 [terminal pd when no current drawn or open circuit scores max 1] 2
- (b) Voltmeter calculation  
 Any attempt to find any current (1)  
 Attempt to calculate pd across 10  $\Omega$  resistor (1)  
 5.77 V 2  
 OR  
 Potential divider method; ratio of resistors with 10.4  $\Omega$  on the bottom (1)  
 Multiplied by 6.0 V (1)  
 5.77 V (1) 3  
 [For either method, an answer of 0.23 V scores max 1]
- (c) Second battery added  
 Voltmeter reading increased (1)  
 Any two of:  
 EMF unchanged  
 Total resistance reduced  
 current increases or “lost volts” decreases (2) 3

[8]

153. (a) Homogeneity  
 $C s^{-1}$  [A] (1)  
 $C, m s^{-1}, m$  [As,  $m s^{-1}, m$ ] (1)
- (b) Not correct:  
 does not take account of numerical constants (1)
- (c) Units of n

$\text{m}^{-3} / \text{cm}^{-3} / \text{mm}^{-3}$  [Not 'per  $\text{cm}^3$ '] (1) 4

[4]

154. (a) Diagram of apparatus

- Trapped gas/fixed mass of gas with fixed volume (1)
- Pressure gauge/U-tube or mercury/Pressure sensor (1)
- Water bath completely surrounding gas (1)
- Thermometer in water bath or gas /Temperature sensor (1)  
[Boyle's law apparatus 0/4]

4

(b) Method

Record pressure and temperature (1)  
for a range of temperatures/ every x K deg C or min, due to heating (1)

Processing results

Plot graph of p against T (1)  
for temp in Kelvin straight line through origin (1)

OR

Calculate p/T average (1)  
and show it is constant for Kelvin temperatures (1)

QOWC (1)

5

(c) Precaution

- Stir water (1)
- Remove energy and await steady temperatures (1)
- Wide range of readings/extend range by use of ice bath (1)
- Eye level with mercury meniscus (1)
- Short/thin tube between gauge and sensor (1)

max 1

[10]

155. Internal energy & Hammer

(a) (i) Internal energy

Kinetic energy and/or potential energy (1)

Molecules have KE and PE (1)

2

(ii) Kinetic energy

Correct substitution in formula (1)

$\text{KE} = 27 \text{ J}$  (1)

2

Temperature rise

$mc\Delta\theta = \Delta\text{KE}$  with  $m = 0.18 \text{ kg}$  (1)

See 27 J/30 J multiplied by 10 (1)

12 (11.5 or 11.6) deg. C/K. or 13 (12.8) deg. C/K (1)

3

(b)	<u>Table</u>		
	Heat energy/thermal energy change/gain of the lead	-/negative (2) OR 0/zero	
	Work done on lead +/-positive (2)		4

[11]

156.	(a)	(i)	<u>Assumptions</u>		
			1. (All) collisions are elastic/molecules do not lose KE (1)		
			2. Time for collision is negligible <u>in comparison</u> to time between collision (1)		
			3. Volume/size of molecules is negligible <u>in comparison</u> to volume of gas/volume of container. (1)		
			4. Range of the forces is small compared to the average molecular separation OR forces are negligible except during collision (1)		
			5. Between collisions molecules move at constant speed (1)		
			6. There is a large number of molecules/collisions (1)		
				ANY THREE (3)	3

Density of gas and KE of molecules

(ii)	$\rho = Nm/V$ (1)	1
------	-------------------	---

(iii)	$KE = \frac{1}{2} m \langle c^2 \rangle$ (1)	1
-------	--	---

(b)	<u>Pressure proportional to temperature</u>		
	substitute for density in the pressure equation (1)		
	$\frac{1}{2} m \langle c^2 \rangle = 3pV/2N$ (1)		
	Equate this expression to constant xT (1)		3

(c)	<u>Temperature calculation</u>		
	Use of $p_1/T_1 = p_2/T_2$ (1)		
	$T_1 = 293$ K (1)		
	Temperature 684 K/411 °C (1)		3

[11]

157.	(a)	(i)	Potential difference = work (done)/(unit) charge OR Potential difference = Power/current (1)		1
		(ii)	$J = \text{kg m}^2 \text{s}^{-2}$ (1)		
			$C = \text{A s}$ or $W = \text{J s}^{-1}$ (1)		
			$V = \text{kg m}^2 \text{A}^{-1} \text{s}^{-3}$ (1)		3

- (b) Converts 2 minutes to 120 seconds (1)  
 Multiplication of  $VI\Delta t$  or  $V\Delta Q$  (1)  
 Energy = 1440 J (1) 3  
 Example of answer:  
 Energy =  $6.0 \text{ V} \times 2.0 \text{ A} \times 120 \text{ s}$   
 = 1440 J

[7]

158. (a)  $n$  = number of charge carriers per unit volume OR  
 $n$  = number of charge carriers  $\text{m}^{-3}$  OR  
 $n$  = charge carrier density (1)  
 $v$  = drift speed/average velocity/drift velocity (of the charge carriers) (1) 2
- (b)  $n$  is greater in conductors /  $n$  less in insulators. (1)  
 [There must be some comparison]  
 larger current flows in a conductor. Dependant on having  
 referred to  $n$  (1) 2  
 (statement that  $n$  large in conductor and so current large max1)
- (c) (In series), so same current and same  $n$  and  $Q$  (1)  
 $v_B$  greater  $v_A$  (1)  
 $v_A/v_B = 1/4 // 0.25$  (1) 3

[7]

159. (a) pd = 3.6 V (1) 1  
 Example of answer;  
 p.d. =  $0.24 \text{ A} \times 15 \Omega = 3.6 \text{ V}$
- (b) Calculation of pd across the resistor (1)  
 [6.0 – 3.6 = 2.4 V]  
 Recall  $V = I_R$  (1)  
 $I_1$  calculated from their pd /  $4\Omega$  (1)  
 [correct answer is 0.60 A. Common ecf is  $6\text{V}/4\Omega$  gives 1.5 A] 3  
 Example of answer:  
 $I_1 = 2.4 \text{ V} / 4.0 \Omega = 0.6 \text{ A}$
- (c) Calculation of  $I_2$  from  $I_1 = 0.24$  [0.36 A] (1)  
 [allow ecf of their  $I_1$ . common value = 1.26 A]  
 Substitution  $V = 3.6 \text{ V}$  (1)  
 $R = 10 \Omega$  (1) 3

[7]

160. (a) (i) (– gradient =)  $r = 1.95 - 2 \Omega$  (1)  
 $E = 8.9 - 9 \text{ V}$  (1) 2
- (ii)  $I = 2.15 - 2.17 \text{ A}$  (1) 1
- (iii) Use of  $V = IR$  (1)  
 $R = 2.1 - 2.2 \Omega$  (1) 2
- (b) (i) Battery or cell with one or more resistive component (1)  
 Correct placement of voltmeter and ammeter (1) 2
- (ii) Vary  $R$  e.g. variable resistor, lamps in parallel (1)  
 Record valid readings of current and pd (consequent mark) (1) 2

[Do not give these marks if the candidate varies the voltage as well]

[9]

161. (a)	$p$	pressure	$\text{N m}^{-2}$ // Pa	(1)	4
	$V$	volume	$\text{m}^3$	(1)	
	$n$	number of moles /amount of substance	mol	(1)	
	$T$	temperature	K	(1)	

[accept words for the units]

- (b) use of  $V_1/T_1 = V_2/T_2$  (1)  
 conversion of °C to K (1)  
 final volume =  $1.5 \times 10^{-4} \text{ m}^3$  (1)  
 answer 167 (°C) (1) 4

Example of answer:

$$\frac{1.0 \times 10^{-4} \text{ m}^3}{293 \text{ K}} = \frac{1.5 \times 10^{-4} \text{ m}^3}{T^2}$$

$$T_2 = 439.5 \text{ K}$$

[8]

162. (a) L = energy /unit mass or /kg (1)  
 during a change of state, solid – liquid (1)  
 at constant temperature (1) 3

- (b) (i) Increasing temperature starting at 600 °C finishing at 700 °C (1)  
 Any horizontal section (1)  
 Horizontal section at 660°C (1) 3
- (ii) Initially KE of molecules/atoms increases (1)  
 Horzt part: PE of molecules/atoms increases (1)  
**During change of state**  
 Temperature remains constant OR kinetic energy unchanged (1)  
 Bonds break OR molecules move further apart (1) 4

[10]

163. (a) (i) energy = 7.5 MJ (1)  
 conservation of energy (1) 2
- (ii) energy source needed because (thermal) energy is moving (1)  
 from cold to hot **OR** moving up a (temperature) gradient 1  
**OR** moving against the (temperature) gradient  
 [Do not penalise heat used for energy]
- (iii) recall of  $P = E/t$  (1)  
 power = 52 W // 187500 J h<sup>-1</sup> // 3125 J min<sup>-1</sup> (1) 2

- (b) use of  $E = m c \Delta\theta$  and correct  $\Delta\theta$  (20 K) (1)  
use of  $E = m L$  (1)  
answer =  $1.4 \times 10^5$  J [ $1.449 \times 10^5$  J] (1) 3

Example of answer:

$$\begin{aligned} \text{Energy temp drop} &= 0.35 \text{ kg} \times 4.2 \times 10^3 \text{ J kg}^{-1} \text{ K}^{-1} \times 20 \text{ K} \\ &= 29400 \text{ J} \end{aligned}$$

$$\begin{aligned} \text{Energy for change of state} &= 0.35 \text{ kg} \times 3.3 \times 10^5 \text{ J kg}^{-1} \\ &= 115\,500 \text{ J} \end{aligned}$$

$$\text{Total energy} = 29400 + 115500 = 144900 \text{ J}$$

- (c)
- Qowc (1)
  - Fins remove thermal energy / cool the air (1)
  - Hot air rises **OR** cold air sinks **OR** hot air less dense **OR** cold air more dense (1)
  - Fins at top cause convection, fins at bottom do not cause convection (1) 4

**[12]**