

ResultsPlus

Examiners' Report June 2010

GCE Physics 6PH02

ResultsPlus
look forward to better exam results
www.resultsplus.org.uk

Edexcel is one of the leading examining and awarding bodies in the UK and throughout the world. We provide a wide range of qualifications including academic, vocational, occupational and specific programmes for employers.

Through a network of UK and overseas offices, Edexcel's centres receive the support they need to help them deliver their education and training programmes to learners.

For further information, please call our GCE line on 0844 576 0025, our GCSE team on 0844 576 0027, or visit our website at www.edexcel.com. If you have any subject specific questions about the content of this Examiners' Report that require the help of a subject specialist, you may find our Ask The Expert email service helpful.

Ask The Expert can be accessed online at the following link:

<http://www.edexcel.com/Aboutus/contact-us/>

Alternatively, you can speak directly to a subject specialist at Edexcel on our dedicated Science telephone line: 0844 576 0037



ResultsPlus is Edexcel's free online tool that offers teachers unrivalled insight into exam performance.

You can use this valuable service to see how your students performed according to a range of criteria - at cohort, class or individual student level.

- Question-by-question exam analysis
- Skills maps linking exam performance back to areas of the specification
- Downloadable exam papers, mark schemes and examiner reports
- Comparisons to national performance

For more information on ResultsPlus, or to log in, visit www.edexcel.com/resultsplus.

To set up your ResultsPlus account, call 0844 576 0024

June 2010

Publications Code US024542

All the material in this publication is copyright
© Edexcel Ltd 2010

6PH02 01

The majority of AS candidates sit this unit in the June series and so this was the first time that we had a large number of candidates taking the paper since the time was increased by ten minutes. It was clear that candidates benefited from this, since there were far fewer blank questions compared to last summer, when some candidates struggled to complete the paper.

Whereas a lot of the candidates scored several marks on most of the questions, there were instances where marks were lost through careless errors, misreading the questions or not giving enough detail in the responses. Particularly in descriptive passages, candidates need to look at the marks available and try to be objective about how many different physics points they have made.

Some candidates still don't realise that for some questions they need to use data from the data and formula sheet at the back of the paper.

In questions where the quality of written communication was assessed, candidates generally expressed themselves well. Marks were lost, not because of poor communication, but lack of correct physics details. Using bullet points is a good technique and an effective way of answering these questions.

The multiple choice questions provided good discrimination with the performance on these questions, generally matching the performance on the rest of the questions for this paper.

The following is a break down of how well the multiple choice questions were answered in percentages overall.

Question 9	84% factors affecting current
Question 8	78% wave particle duality
Question 4	76% power calculation
Question 7	73% phase differences on a graph
Question 2	62% EM spectrum, frequencies and wavelengths
Question 1	61% units
Question 6	57% echo calculation
Question 3	50% current at a junction
Question 10	15% finding a series current from a V-I graph

Obviously Question 10 was the most difficult and it did require candidates to realise that at the correct current (0.3 A), the potential differences across the components would add up to 9 V.

Question 11

Whilst a lot of candidates successfully scored all three marks for this question, there were two mistakes that occurred quite frequently. One was a power of ten error, with candidates often converting the frequency as if it were in kHz rather than MHz. Some candidates also stated that the MHz were mHz. Presumably because this question was about radio waves, quite a few candidates chose to use the speed of sound rather than the speed of light.



ResultsPlus

Examiner Comments

This shows a candidate who has selected the correct data and converted MHz correctly, but is unable to rearrange the simplest of formula. This candidate scores 2 marks.

11 A London radio station broadcasts at a frequency of 95.8 MHz. Calculate the wavelength in air of these radio waves.

$$3 \times 10^8$$

$$\lambda = \frac{f}{v}$$

$$v = f\lambda$$

$$\frac{95.8 \times 10^6}{3 \times 10^8} = 0.3193$$

Wavelength = 0.3193



ResultsPlus

Examiner Tip

Rearranging equations is a basic skill that needs to be practiced constantly.

ResultsPlus

Examiner Comments

An example of a candidate who converted the MHz incorrectly.

- 11 A London radio station broadcasts at a frequency of 95.8 MHz. Calculate the wavelength in air of these radio waves.

$$v = f\lambda \quad 95.8 \text{ MHz} = 95800 \text{ Hz}$$

$$\lambda = \frac{v}{f}$$

$$\lambda = \frac{330}{3.00 \times 10^8}$$

$$\lambda = 3.193 \times 10^{-4}$$

$$\text{Wavelength} = 3.19 \times 10^{-4} \text{ m}$$

ResultsPlus

Examiner Comments

A use of the speed of sound example.

- 11 A London radio station broadcasts at a frequency of 95.8 MHz. Calculate the wavelength in air of these radio waves.

$$v = f\lambda$$

$$\lambda = \frac{v}{f}$$

$$= \frac{330}{95.8 \times 10^6}$$

$$= 3.444676 \dots$$

$$\text{Wavelength} = 3.44 \times 10^{-6} \text{ m}$$

Question 12(a)

Majority of candidates scored one or zero for this question, demonstrating a lack of understanding about resistance and resistivity.

Some candidates who stated that resistivity was a constant for a material, then went on to say that it also depended on dimensions. Most candidates defined resistance for the equation $R = V/I$. Although this equation defines the unit of resistance, current is determined by the potential difference and resistance.

**ResultsPlus**

Examiner Comments

This candidate shows an understanding of the physics, but omits any reference to resistance depending on physical dimensions. This scores 1 mark

12 (a) Explain the difference between resistance and resistivity.

Resistivity is a property of a material and ⁽²⁾ can also vary according to different factors whereas resistance is dependent on the resistivity

**ResultsPlus**

Examiner Comments

an example where candidate incorrectly relates resistivity to length and area and defines resistance in terms of p.d. and current.

Resistivity is dependant on the density, length and area⁽²⁾ of the material. It is a fixed property for a given piece of material.
Resistance is dependant on the potential difference and current of a circuit, and can be changed as a property.

**ResultsPlus**

Examiner Tip

Equations give you a mathematical relationship between variables but do not tell you which variable is dependant on the others. This needs to be learnt.

Question 12(b)

This question required a straightforward substitution into a formula to find a resistance and not surprisingly the majority of candidates scored both marks. Where errors were made, it was because of the omission of a unit or confusion between resistance and resistivity. Some candidates chose to rearrange the equation and substitute resistivity as resistance.



ResultsPlus

Examiner Comments

A significant number of candidates gave this answer, where they confused resistance and resistivity.

(b) The resistivity of copper is $1.7 \times 10^{-8} \Omega \text{ m}$. A copper wire is 0.50 m long and has a cross sectional area of $1.0 \times 10^{-6} \text{ m}^2$. Calculate its resistance. (2)

$$R = \frac{\rho l}{A} = \frac{1.7 \times 10^{-8}}{1.0 \times 10^{-6}} = \frac{0.5}{1.0 \times 10^{-6}}$$

$$= 3.4 \times 10^{-14} \Omega$$

Resistance = $3.4 \times 10^{-14} \Omega$



ResultsPlus

Examiner Tip

Make sure that you know what all the symbols in the equation stand for.

Question 13

This was a relatively straightforward question, using potential dividers and thermistors. Nearly all candidates were able to read the value of resistance of the graph. Although, only the most able candidates are able to cope with the concept of a potential divider, this question can be correctly answered by finding the total resistance, then the current and finally the potential difference across the 1 kilo-ohm resistor.

Unfortunately, most candidates who chose to follow this route did not find the total resistance and did a current calculation using one of the resistances, instead of the total resistance. A significant number of candidates calculated a p.d. greater than 6 V and did not think that this was wrong. For the last part, it was necessary for candidates to identify that, it was the resistance of the thermistor that increased.

13 The following circuit is used to monitor the temperature in a greenhouse. The battery has no internal resistance.

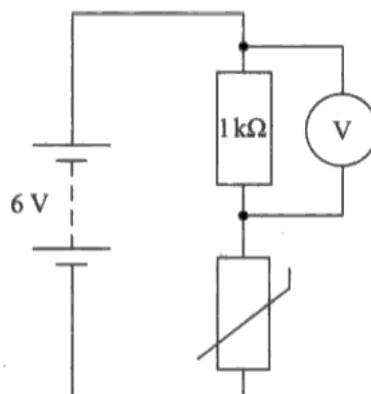

(a) The graph shows how the resistance of the thermistor varies with temperature.

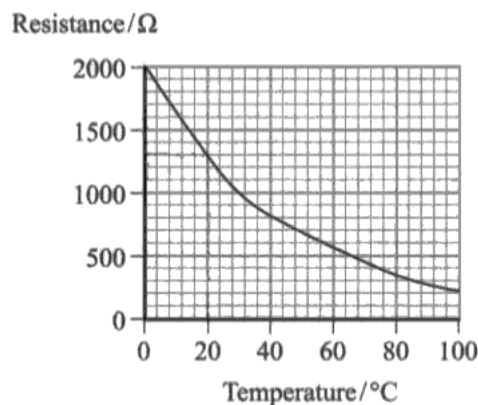

(i) Use the graph to find the resistance of the thermistor at 20 °C.

(1)

Resistance = 1300 Ω

(ii) Calculate the reading on the voltmeter when the thermistor is at 20 °C.

(3)

~~power~~ $V = IR$. $I = \frac{V}{R}$

~~1000~~ $6 \div 100 = \frac{3}{50}$

$$V = 1000^3 \times \frac{3}{50} = 4.615384615$$

$$= 4.62 \text{ V}$$

Reading on the voltmeter = 4.62 V

(b) Explain what will happen to the reading on the voltmeter as the temperature of the greenhouse decreases.

(2)

The reading on the voltmeter will decrease as the temperature of the greenhouse decreases. This is because there is resistance in the circuit, ^{increase} due to decrease in temperature and as a result the current in the circuit will decrease.



ResultsPlus

Examiner Comments

This candidate found a current using just the thermistor's resistance. In the last part, there is no mention of the thermistor.

$V = IR$

$6 = I 1000$

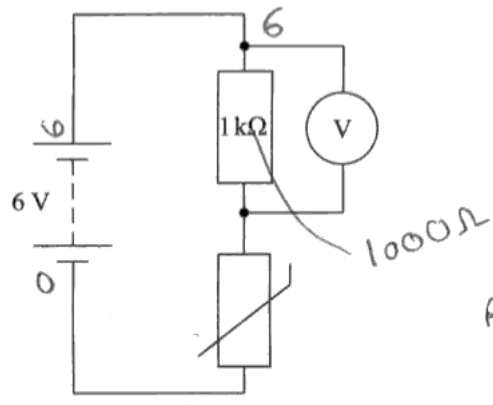

$R = \frac{V}{I}$

(a) The graph shows how the resistance of the thermistor varies with temperature.

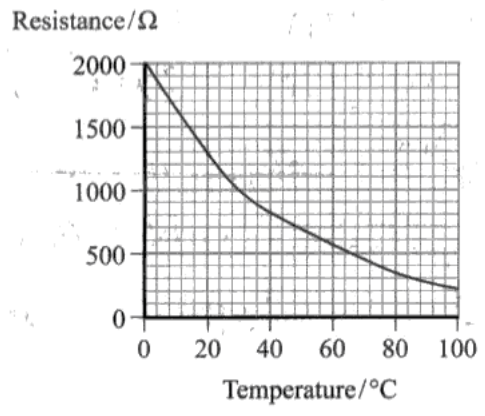

(i) Use the graph to find the resistance of the thermistor at 20 °C.

Resistance = 1300 Ω (1)

(ii) Calculate the reading on the voltmeter when the thermistor is at 20 °C.

$$V = IR \quad 6 = I 1000 \quad I = 6 \times 10^{-3} \quad (3)$$

$$R = 1300 \quad I = 6 \times 10^{-3} \quad V = ?$$

$$V = (6 \times 10^{-3}) \times 1300 =$$

$$\text{Reading on the voltmeter} = 7.8 \text{ V}$$

(b) Explain what will happen to the reading on the voltmeter as the temperature of the greenhouse decreases.

As the temperature decreases, the resistance increases. Resistance & voltage are proportional thus the reading on the voltmeter will increase also. (2)



ResultsPlus

Examiner Comments

an example where the reading on the voltmeter is greater than 6 V. The last part shows that the candidate has little understanding about potential dividers.



ResultsPlus

Examiner Tip

Check if your answer is sensible. The p.d. across one component in a circuit can't be greater than the p.d. of the supply.

Question 14

Candidates need to read the question and think about what is actually being asked. This question was about interference patterns and not as many thought, reflection and refraction.

Also the context of the question was the coloured films that are frequently seen on oil patches. However, the question specified that monochromatic light was used. Some candidates obviously did not understand the word monochromatic, but others just ignored it. There were many well written answers, all about refraction and total internal reflection that did not score any marks or at best one mark, for identifying that there were two rays involved.

Candidates who did talk about interference, usually scored well. If marks were lost, it was usually because, they did not make five physics points. One error that does occur is to confuse path difference and phase difference. Either route can score the marks, but a mixed sentence such as 'when there is a phase difference of an odd number of half wavelengths' will not score the marks.



ResultsPlus

Examiner Comments

Bullet points are acceptable for QWC questions. This candidate starts with reflection and refraction, but only scores marks in the last but one bullet point. It scores 2 marks for identifying two waves and a path difference.

- The light source is shown on top of the oil
- Some of the light hits the ~~oil~~ oil at an angle greater than the critical angle and is reflected
- Some of the light hits at an angle less than the critical angle and undergoes refraction in the oil of distance ' n '
- The returning light has a path difference of $2n$ and is now out of phase with the first beam
- Thus an interference pattern is created

**ResultsPlus**

Examiner Comments

This example also starts with refraction but quickly gets into interference. This is an answer that uses the thickness of the film to answer the question. Although not strictly correct, it was felt that this demonstrated understanding of the principles of interference and was credited.

As light strikes the surface of the oil it will get reflected and refracted. The refracted light will reflect off the surface of the water and refract out the oil into the air. These two rays of light will have a path difference. If the thickness of the oil is $\lambda/4$ the two waves will be half a wave length out of phase / in antiphase. This means they will destructively interfere so this part will be dark (not as much light).

If the thickness is $\lambda/2$ the two waves will be in phase. This means they will constructively interfere so this part will be brighter. Not all the oil over the surface will be the same thickness so there will be different parts (patches) of dark and bright light.

Question 15(a)

In (a) many candidates did not read the question properly and thought that using $P=VI$, an equation that included V and I was sufficient. Whereas the question, clearly asked for expressions for current and potential difference. Candidates who did this, scored zero.

The mark scheme allowed candidates to work in either units or quantities. The easiest route was to use units, since $J/C \times C/s$ easily becomes J/s i.e. a watt.

Candidates who chose to use quantities invariably, used W as energy (as on the formula sheet) but then, ran into difficulties in distinguishing between energy and watts.



ResultsPlus

Examiner Comments

This candidate starts well with correct expressions but is not able to justify the equivalence of the units

$$I = \frac{\Delta Q}{\Delta t} \quad P = \frac{\Delta W}{\Delta t} \quad V = \frac{\Delta W}{\Delta Q}$$

$$\Delta Q = I \Delta t \quad \Delta W = V \Delta Q$$

$$\Delta t = \frac{\Delta Q}{I} \quad P = \frac{V \Delta Q}{\frac{\Delta Q}{I}} \quad P = \frac{V}{\frac{1}{I}} \quad P = \frac{V}{A} \quad P = VA^{-1}$$

$$W = VA^{-1}$$



ResultsPlus

Examiner Comments

An example that scores all three marks.

$$p.d = V = \frac{E}{Q} = J C^{-1} \quad I = A = C s^{-1}$$

$$P = IV = J C^{-1} \times C s^{-1} = J s^{-1}$$

$$1 \text{ watt} = \frac{\Delta W}{t} = J s^{-1}$$



ResultsPlus

Examiner Tip

Learn all basic definitions in terms of quantities and units

**ResultsPlus**

Examiner Comments

The most common answer; just using the power formula which scored zero.

Power = voltage \times current, and the unit of power is the Watt, the unit of voltage is the volt, and current is the amp. so $\text{watt} = \text{volt} \times \text{amp}$ (volt-amp)

Question 15(b)(i)

This question was generally answered well, with most candidates scoring both marks. Some unit errors, but generally on this question candidates got their units correct.

Question 15(b)(ii)

The stem of part (b) of this question, told candidates that the battery had an internal resistance and noticing this heavy hint, was key to answering the last part of the question. The majority of candidates made no reference to internal resistance and consequently rarely scored any marks.

A substantial number of candidates ignored the question that was asked 'why the time more than doubles' and just said that halving the power doubles the time.

Other candidates were very inventive with their equations of inverse proportion, in order to try to justify why the time doubled. Only a very small number of candidates scored all three marks.

**ResultsPlus**

Examiner Comments

Common wrong answer, ignoring the fact that the time more than doubles.

This is because when the power is halved, the same amount of energy is still used, therefore to maintain this, the power would have to be used for a much longer time.

**ResultsPlus**

Examiner Comments

This candidate has successfully scored all three marks by realising that the current is reduced, thus lowering the energy loss on the internal resistance.

by halving the power output the efficiency of the system improves as well meaning an extension of the battery life on top of halving the energy being supplied. as less current is drawn less energy is wasted by internal resistance.

Question 16

This was a relatively straightforward question on refraction and although many candidates scored well on this question, surprisingly few scored full marks.

Candidates who got their angles confused in (a) and got a refractive index of 0.67 ran into problems in (b)(ii), when they then had a sine greater than 1. Most candidates at this stage just inverted the calculation and appeared to have the correct answer, although they were not given credit. What candidates seem unable to do, is to realise that there was something wrong with their value of refractive index and go back and revisit their first calculation.

In (b)(i), it was unusual to award three marks, the majority of candidates scoring 1 or 2. It wasn't that what they wrote was incorrect, it was that, there wasn't enough information. Candidates either concentrated on up to the critical angle or after the critical angle, not both.

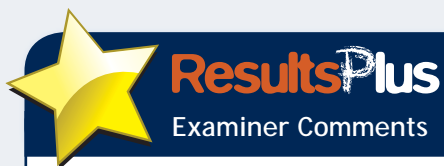

An example where the candidate focuses on what happens after the critical angle has been reached.

- (a) Calculate the refractive index from air to glass n_{g} .

(2)

$$\frac{\sin i}{\sin r} = \frac{\sin 48}{\sin 30} = 1.49$$

Refractive index = 1.49

- (b) (i) The student steadily increases the angle x in glass and finds that eventually the light does not pass into the air. Explain this observation.

(3)

As the angle x increases, it eventually meets and exceeds the critical angle. Any angle above this critical angle will cause total internal reflection to happen, meaning that all the light will reflect off the straight edge of the block and none of it will refract into air.

- (ii) Calculate the largest value of angle x that allows the light to pass out of the block into the air.

(2)

$$\sin c = \frac{1}{1.49} \quad c = \sin^{-1}(0.67)$$

$$c = 42.28$$

Angle = 42.28



ResultsPlus

Examiner Comments

This answer deals with just the critical angle and doesn't go beyond it.

- (a) Calculate the refractive index from air to glass n_{g} .

(2)

$$n_{\text{g}} = \frac{\sin y}{\sin x} = \frac{\sin 48}{\sin 30} = 1.486$$

Refractive index = 1.49.

- (b) (i) The student steadily increases the angle x in glass and finds that eventually the light does not pass into the air. Explain this observation.

(3)

This is the critical angle when the light is not refracted or reflected. The light passes down the flat side of the glass. Angle $y = 90^\circ$.

- (ii) Calculate the largest value of angle x that allows the light to pass out of the block into the air.

(2)

$$\frac{1}{n_{\text{g}}} = \sin C \quad \frac{1}{1.49} = \sin C \quad C = \sin^{-1} 0.67.$$

$$C = 42^\circ$$

Angle = ~~42~~ $< 42^\circ$

Question 17

This question was about how the energy of photoelectrons varied with frequency of incident radiation and so in (a), candidates needed to refer to the photon energy.

The most common answer was to identify the given frequency as the threshold frequency, which while being correct, does not answer the question.

The 'easy' way to answer (b), was to take that threshold frequency, use $E = hf$ and convert answer to eV. There were other routes, e.g. substituting into the equation or drawing similar triangles etc, which all got full credit, but by being more complex, there was a greater risk of errors being made.

A large number of candidates correctly identified the gradient as Plank's constant, but weren't always successful in representing that on a graph, where the work function changes. The most common wrong answer, was to have the same intercept on the x-axis but with a different gradient.



ResultsPlus

Examiner Comments

This candidate, has taken a pair of values to substitute into the equation, but forgets to convert Joules to eV, so scores 1 mark.

(b) Calculate the work function of aluminium in electron volts.

(3)

$$hf = \phi + \frac{1}{2}mv^2$$

$$\phi = hf - \frac{1}{2}mv^2$$

$$= (6.63 \times 10^{-34} \times 1.8 \times 10^{14}) - (3 \times 1.6 \times 10^{-19})$$

$$= 7.134 \times 10^{-19}$$

Work function = 7.1×10^{-19} Hz (2sf)

**ResultsPlus**

Examiner Comments

An example of the easiest way to score three marks.

(b) Calculate the work function of aluminium in electron volts.

(3)

$$\phi = hf$$

$$= 6.63 \times 10^{-34} \times 10 \times 10^{14}$$

$$= 6.63 \times 10^{-19} \text{ J}$$

$$= \frac{6.63 \times 10^{-19}}{1.6 \times 10^{-19}} = 4.14 \text{ eV (3.s.f.)}$$

Work function = 4.14 eV

Question 18(a)

The first part of the question was meant to be a very easy circuit diagram, but a lot of candidates failed to score marks because they did not identify their wire.

Many circuits looked as though, there was an ammeter in series, with a supply with a voltmeter across it. Although candidates could score both marks by identifying a wire and correctly positioning the instruments, it was disappointing that candidates did not realise that, they also needed a variable supply or a variable resistor.



ResultsPlus

Examiner Comments

A clearly identifiable wire

18 A length of wire has a cross-sectional area of $3.1 \times 10^{-6} \text{ m}^2$. A current of 1.5 A flows through the wire when there is a p.d. of 3.0 V across it.

(a) Draw a diagram of the circuit you would use to check these current and p.d. values.

(2)

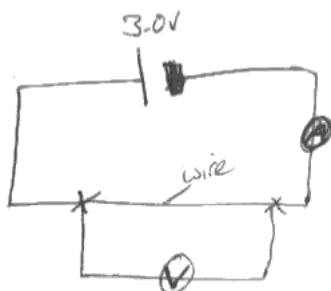

ResultsPlus

Examiner Comments

A very common answer with a voltmeter in parallel with an ammeter, but where is the wire?

18 A length of wire has a cross-sectional area of $3.1 \times 10^{-6} \text{ m}^2$. A current of 1.5 A flows through the wire when there is a p.d. of 3.0 V across it.

(a) Draw a diagram of the circuit you would use to check these current and p.d. values.

(2)

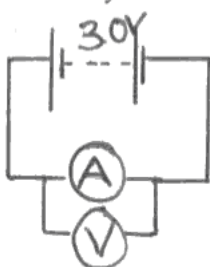

Question 18(b)

This was an easy calculation that the majority of candidates got right. Some of the weaker candidates, gave the unit as Joules instead of Watts.

Question 18(c)(i)

The first part of this section required candidates to rearrange an equation and to find, from the data sheet, the value for the charge on an electron.

Whilst a lot of candidates could do this successfully for many, these are skills that they need to improve. This question was about drift velocity of electrons and what happens to them when the temperature of the wire increases, i.e. it is what happens at the microscopic level in terms of molecular vibrations and interactions between the electrons and the molecules. Many candidates chose to answer this in terms of increased resistance, which meant that they could not access the full marks.



ResultsPlus

Examiner Comments

Although this candidate does identify the value for e , the equation is incorrectly rearranged.

$$I = nqAvd$$

$$V = \frac{I n q}{A}$$

$$\frac{1.5 \times 1.0 \times 10^{29} \times 1.6 \times 10^{-19}}{3.1 \times 10^{-6}} = 7.74 \times 10^{15}$$

Drift velocity = 7.74×10^{15} .



ResultsPlus

Examiner Tip

Rearranging equations is a basic skill that can be practised repeatedly, so as to avoid losing marks.

Question 18(c)(ii)

This part of the question was about drift velocity of electrons and what happens to them when the temperature of the wire increases, i.e. it is what happens at the microscopic level in terms of molecular vibrations and interactions between the electrons and the molecules.

Many candidates chose to answer this in terms of increased resistance which meant that they could not access the full marks.



ResultsPlus

Examiner Comments

This answer does score two marks, but there is clearly not enough points made for three marks to be awarded.

The drift velocity will decrease as there will be an increase in resistance as the electrons gain energy.



ResultsPlus

Examiner Tip

Always look at the marks and try to make enough different physics points.

Question 19(a)

This is the second spreadsheet question in this unit and there was evidence that the candidates had learnt from the January series example. Candidates must be aware of not just rewriting the question, when giving their answers. Part (a)(i), required candidates to identify the wave speed equation and that the wave length was twice the length of the string. Since the formula was given, candidates were not credited with the marks, by simply substituting the column headings into the given formula.

The question also says that the candidates records certain readings and uses them to calculate other values using the equation given. i.e. the columns build up from right to left. This means that the value in any one cell can only be found from cells to the left of it and not the right.

In (ii) and (iii), where candidates were asked for a formula, they were not penalised for power of ten errors. However, as in the January exam, in (iv) and (v), where values of cells were being found, candidates were expected to give just what would appear in the cell i.e. 5.12 and 82. Powers of 10 and units should not be there, because they are given in the table. As with unit penalties, candidates were only penalised once if they made this mistake.

Question 19(b)

This part was very poorly answered. Candidates did not seem to realise that if the equation was correct, a straight line graph passing through the origin would be obtained. There were often references to the straight line part, but rarely any references to the origin.

Evidence from responses suggest that candidates did not read the question properly. The question is about one string being removed from the guitar, that one string will have a fixed value for the mass per unit length. This means that the graph plotted should be relating expressions for velocity and tension, but a large number of candidates wanted to plot tension against mass per unit length.



ResultsPlus

Examiner Comments

A common answer where the candidate, thinks that the mass per unit length of a string is a variable. There is no reference to obtaining a straight line through the origin.

The equation $v = \sqrt{\frac{T}{\mu}}$ can be changed to $v^2 = T \times \frac{1}{\mu}$. If you plot v^2 up the y-axis and $\frac{1}{\mu}$ along the x-axis, the tension would be the gradient



ResultsPlus

Examiner Comments

This suggests a sensible graph to plot and correctly identifies the gradient but there is no mention of the graph passing through the origin

If she plotted v^2 on the y-axis & T on the x-axis she would get $\frac{1}{\mu}$ as the gradient. If the line was straight for varying the values of T then the equation stands.

Question 20(a)-(b)

Very few candidates realised that the reason that microwaves are used, is because of the need to minimise diffraction. Amusingly many thought that radiowaves would interfere with the car radios. Other than that, most candidates could correctly identify the wavelength differences and the frequency change for the reflected wave.

In (ii), not many candidates realised that there needed to be a comparative value to compare the frequency change with.

**ResultsPlus**

Examiner Comments

This was a very common answer with the omission of diffraction and no comparison element in the last part.

(a) A narrow beam of waves is necessary to pick out a single car. Suggest a reason why microwaves are used rather than radio waves.

(2)

because microwaves have a smaller wave length and higher frequency so are faster.

(b) (i) State how the frequency of the reflected signal would differ from the frequency of the transmitted signal.

(1)

the frequency reflected will be greater than the frequency transmitted.

(ii) Explain how the system detects that a car is speeding.

(2)

because the difference in ~~wave~~ frequency ~~will~~ can be used to produce a speed which will show if the car is speeding or not.

Question 20(c)

Many candidates were successful with these calculations, often scoring full marks. Various errors were made, intensity/area, incorrect finding of 8% etc, but candidates were given credit in (ii) if they used their value from (i) correctly.

Grade boundaries

Grade	Max. Mark	A	B	C	D	E	N
Raw mark boundary	80	52	46	40	34	29	24

Further copies of this publication are available from
Edexcel Publications, Adamsway, Mansfield, Notts, NG18 4FN

Telephone 01623 467467

Fax 01623 450481

Email publications@linneydirect.com

Order Code US024542 June 2010

For more information on Edexcel qualifications, please visit
www.edexcel.com/quals

Edexcel Limited. Registered in England and Wales no.4496750
Registered Office: One90 High Holborn, London, WC1V 7BH

Ofqual



Llywodraeth Cynulliad Cymru
Welsh Assembly Government

