

Centre No.						Paper Reference		Surname	Initial(s)
Candidate No.						<b>6 7 3 6 / 0 1</b>		Signature	

Paper Reference(s)

**6736/01**

**Edexcel GCE**

**Physics**

**Advanced Level**

**Unit Test PHY6**

**Tuesday 17 June 2008 – Afternoon**

**Time: 2 hours**

Examiner's use only

--	--	--

Team Leader's use only

--	--	--



M18007066207

Question Number	Leave Blank
1	
2	
3	
4	
<b>Total</b>	

**Materials required for examination**

Nil

**Items included with question papers**

Insert

**Instructions to Candidates**

In the boxes above, write your centre number, candidate number, your signature, your surname and initial(s).

Answer **ALL** questions in the spaces provided in this question paper.

In calculations you should show all the steps in your working, giving your answer at each stage.

Calculators may be used.

Include diagrams in your answers where these are helpful.

**Information for Candidates**

This question paper is designed to give you the opportunity to make connections between different areas of physics and to use skills and ideas developed throughout the course in new contexts.

You should include in your answers relevant information from the whole of your course, where appropriate.

You should have an insert that is the passage for use with Section 1.

The marks for individual questions and the parts of questions are shown in round brackets.

There are four questions in this paper. The total mark for this paper is 80.

**The list of data, formulae and relationships is printed at the end of this booklet.**

**Advice to Candidates**

You will be assessed on your ability to organise and present information, ideas, descriptions and arguments clearly and logically, taking account of your use of grammar, punctuation and spelling.

This publication may be reproduced only in accordance with Edexcel Limited copyright policy. ©2008 Edexcel Limited.

Printer's Log. No.

**M30414A**

W850/R6736/57570 7/6/6/5/5/1



M 3 0 4 1 4 A 0 1 2 4

*Turn over*

### SECTION I

1. Read the passage on the separate insert and then answer the Section I questions.

(a) Use the first paragraph to estimate, to an order of magnitude, the distance between the Sun and the Earth.

.....

.....

.....

.....

.....

.....

.....

.....

.....

.....

(5)

(b) In the space below draw a magnetic dipole and sketch the magnetic field pattern around it.

(2)



(c) A high speed proton in the solar wind enters the Earth's magnetosphere heading directly for the Earth.

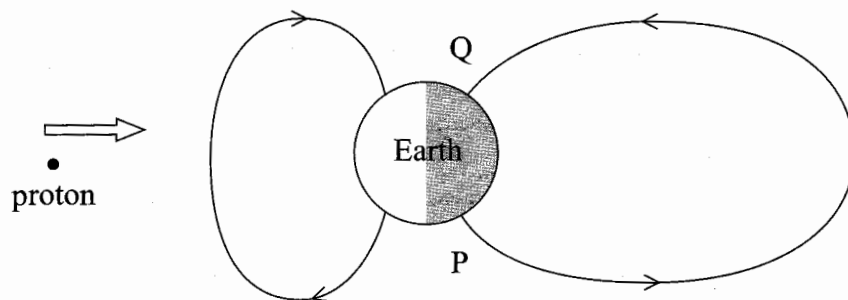

(i) In which direction will the proton be deflected by the Earth's magnetic field?

.....  
 .....

Explain how you determined the direction.

.....  
 .....

(ii) A different proton subsequently becomes trapped in the magnetosphere. Add to the diagram to show the shape of the path it follows, the centre of which is the magnetic field line PQ.

(4)



(d) Consider a proton that is reflected, i.e. makes the transit from one pole to the other, every 1.2 s and continues to do so for exactly 3 days. Assume that it makes on average one ionising collision after every hundred transits.

(i) Show that this proton makes about 2000 ionising collisions.

.....  
.....  
.....  
.....  
.....

(ii) Each collision reduces the energy of the proton by 14 eV.

Calculate this proton's initial energy in joules.

.....  
.....  
.....  
.....

(5)



(e) A proton of mass  $m$  and charge  $e$  enters a magnetic field of magnetic flux density  $B$  at a speed  $v$  as shown below.

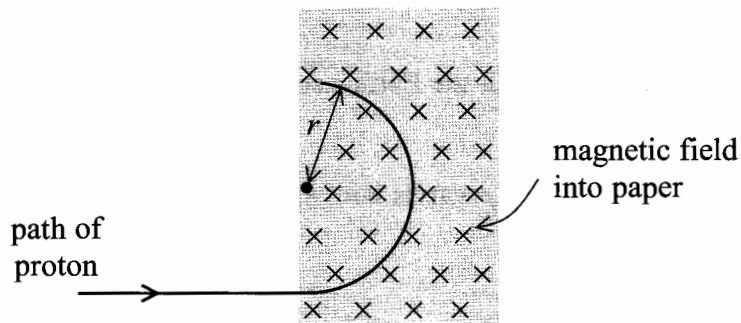

(i) Deduce an expression for the radius  $r$  of the path followed by the proton.

.....

.....

.....

.....

.....

(ii) Calculate a value for  $r$  for a proton moving at a speed of  $2.0 \times 10^6 \text{ m s}^{-1}$  that enters a magnetic field where  $B$  is  $40 \mu\text{T}$ .

.....

.....

.....

.....

.....

(4)



- (f) The density  $\rho$  of nitrogen gas in the Earth's atmosphere varies with height  $h$  according to the relationship

$$\rho = \rho_0 e^{-kh}$$

where  $\rho_0$  is the value of the density at the Earth's surface and  $k$  is a constant of value  $6.5 \times 10^{-5} \text{ m}^{-1}$ .

- (i) Sketch a graph to describe how  $\rho$  varies with  $h$ .

- (ii) Calculate the ratio  $\rho/\rho_0$  at a height of 150 km and hence confirm that at that height the Earth's atmosphere is 'very, very thin'.

.....

.....

.....

.....

.....

.....

**(4)**



(g) (i) Explain how 'these ionisations' (paragraph 3) are produced.

.....  
.....  
.....

(ii) Oxygen and nitrogen atoms produce different hues (colours) after being ionised. Explain how different atoms can produce different hues.

.....  
.....  
.....  
.....  
.....  
.....  
.....  
.....  
.....

(5)



(h) A rocket, of initial mass 400 kg, is launched to investigate the nature of the Earth's atmosphere at heights of up to 200 km.

A student estimates that the gain in gravitational potential energy of the rocket in reaching its maximum height is:

$$\begin{aligned} \Delta(\text{g.p.e.}) &= (400 \text{ kg}) \times (9.8 \text{ m s}^{-2}) \times (200\,000 \text{ m}) \\ &= 7.8 \times 10^8 \text{ J} \end{aligned}$$

(i) State any assumptions the student used in making this estimate.

.....  
.....  
.....  
.....

(ii) Explain why the student's estimate is too big.

.....  
.....  
.....  
.....

(4)

Q1

(Total 33 marks)

**TOTAL FOR SECTION I: 33 MARKS**





**SECTION II**

**(Answer ALL questions)**

2. (a) Draw a labelled diagram to show the principal components of a linear accelerator (linac) for producing high-energy protons.

**(5)**



(b) The dashed line on the graph below shows how the kinetic energy of a proton would vary with the square of its speed if the relationship

$$\text{k.e.} = \frac{1}{2}mv^2$$

were to hold for all values of  $v$ , no matter how high.

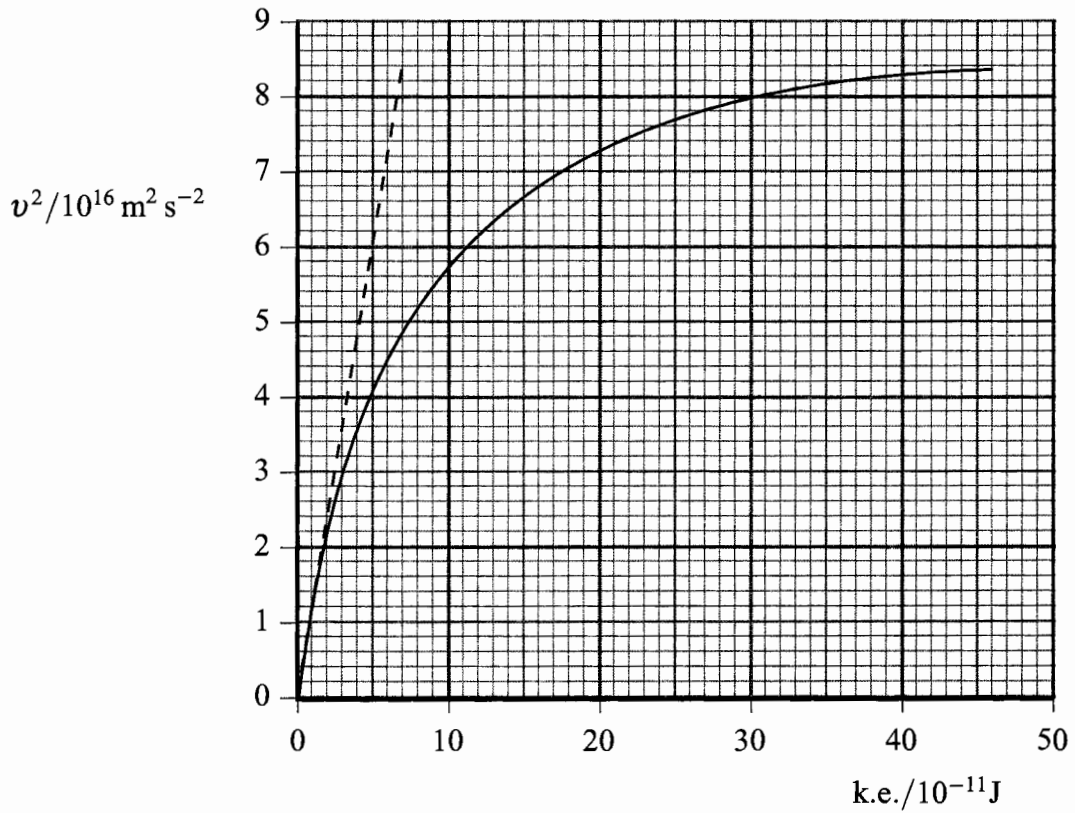

Use data from the graph to show that the rest mass of the proton is about  $1.7 \times 10^{-27} \text{ kg}$ .

.....

.....

.....

.....

.....

.....

.....

.....

(3)



(c) The curved line on the graph shows how the kinetic energy of a high-energy proton actually varies with the square of its speed. This is greater than that predicted by the  $\frac{1}{2}mv^2$  expression because of relativistic effects.

(i) Complete the table below to show the extra energy  $\Delta E$ , caused by relativistic effects, for protons accelerated to the three speeds  $v$  shown in the left column.

$v/10^8 \text{ m s}^{-1}$	$v^2/10^{16} \text{ m}^2 \text{ s}^{-2}$	$\Delta E/10^{-11} \text{ J}$
2.00	4.0	
2.24	5.0	
2.45	6.0	

(ii) For any **one** of your values for  $\Delta E$ , calculate the equivalent mass increase  $\Delta m$  of a proton moving at that speed and express this mass increase as a percentage of the rest mass of a proton.

.....

.....

.....

.....

.....

.....

(5)

(iii) Describe how the curved line on the graph would continue as more and more energy is given to a proton and suggest how this would affect the design of a proton linac.

.....

.....

.....

.....

.....

.....

(3)

(Total 16 marks)

Q2



3. (a) A free-body force diagram for a travel case of total mass 5.5 kg is shown below. The case is being held at rest by a hand at H, and its centre of gravity is at G.

The diagram is drawn to scale at one fifteenth real size.

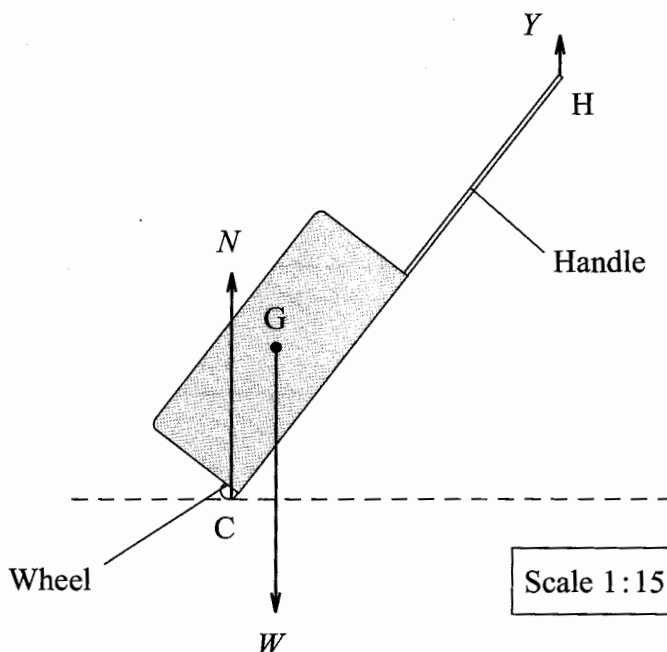

- (i) Use Newton's first law to write an equation relating the sizes of the forces  $N$ ,  $W$  and  $Y$  acting on the case.

.....

- (ii) Use the principle of moments to calculate the size of the force  $Y$ , the upward pull of the hand on the case.

.....  
 .....  
 .....  
 .....  
 .....  
 .....  
 .....

(4)



(iii) State and explain **two** ways in which the force  $Y$  could be reduced without altering the total mass of the case or further extending the handle.

1. ....  
.....  
.....  
.....  
.....  
.....  
.....  
.....
2. ....  
.....  
.....  
.....  
.....  
.....  
.....  
.....

(4)



(b) The owner of the case wheels it onto an electric railcar that is powered from a 750 V d.c. supply rail. The railcar makes a short journey from one terminal of an airport to another.

(i) The graph shows the acceleration of the railcar during this journey.

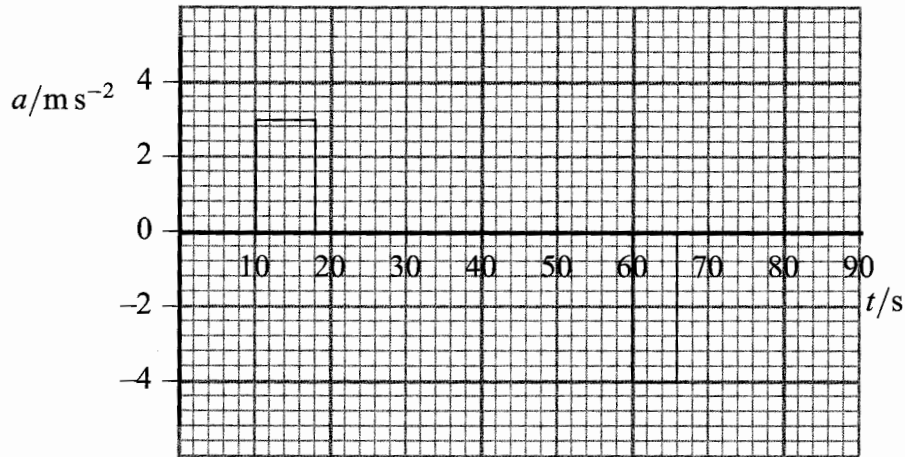

Use the graph to determine the steady speed  $v$  of the railcar during the middle section of the journey.

.....

.....

.....

.....

.....

(ii) Show that the railcar comes to rest at the end of the journey.

.....

.....

.....

.....

.....

(4)



Leave blank

(iii) When moving at the steady speed  $v$  the railcar draws 96 A from the power rail in order to overcome resistive forces that total 3000 N.

Use this data to determine a second value for  $v$ .

.....

.....

.....

.....

.....

.....

(3)

Q3

(Total 15 marks)



4. (a) An upright kitchen freezer – a heat pump – has an internal volume of  $0.20 \text{ m}^3$  and maintains a steady internal temperature of  $-18 \text{ }^\circ\text{C}$ . After the door has been left open for a short time all the cold air in the freezer has been replaced by air at a room temperature of  $22 \text{ }^\circ\text{C}$ .

Show that the energy that needs to be extracted from this air to cool it down to freezer temperature is about 6 kJ. Take the density of air to be  $1.3 \text{ kg m}^{-3}$  and the specific heat capacity of air to be  $610 \text{ J kg}^{-1} \text{ K}^{-1}$ .

.....

.....

.....

.....

.....

.....

.....

.....

.....

.....

(4)

- (b) (i) The diagram shows the principle of a heat pump like the freezer.

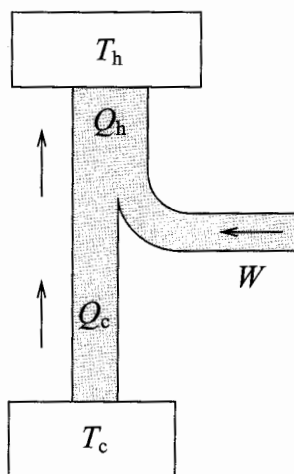



Describe the purpose of such a heat pump, explaining the meanings of the symbols in the diagram as they apply to a freezer.

.....  
.....  
.....  
.....  
.....  
.....  
.....  
.....  
.....  
.....  
.....  
.....  
.....  
.....  
.....

(4)

(ii) Such a freezer has a maximum 'coefficient of performance'  $\eta_p$ , where:

$$\eta_p = \frac{T_c}{T_h - T_c}$$

Calculate a value for the maximum coefficient of performance of this kitchen freezer that maintains an internal temperature of  $-18^\circ\text{C}$  when the room temperature is  $22^\circ\text{C}$ .

.....  
.....  
.....  
.....

(iii) The maximum coefficient of performance  $\eta_p$  can also be expressed as  $Q_c/W$ .

How much energy  $W$  was needed to cool down the air in part (a) above?

.....  
.....  
.....

(3)



- (c) When air is cooled it slows down the random motion of the air molecules and atoms. Gas atoms can be slowed down to extremely low speeds by bombarding them with infra-red photons from a laser.

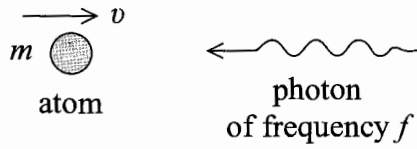

- (i) The momentum of a photon is  $E/c$ , where  $E$  is the photon energy and  $c$  is the speed of light.

Derive an expression for  $\Delta v$ , the change of speed of the atom of mass  $m$ , initially moving at a speed  $v$ , after it has absorbed the on-coming photon.

.....

.....

.....

.....

.....

.....



(ii) Atoms must absorb only on-coming photons. For this to occur  $E$  is made slightly lower than a known transition between two of the atom's energy levels. The Doppler effect then ensures that the atoms 'see' the photons as being of exactly the right energy for absorption.

Show that the apparent energy  $E'$  of the on-coming photon as seen by the atom in the above diagram is given by

$$E' = E \left( 1 + \frac{v}{c} \right)$$

.....

.....

.....

.....

.....

.....

.....

.....

(5)

Q4

(Total 16 marks)

**TOTAL FOR SECTION II: 47 MARKS**

**TOTAL FOR PAPER: 80 MARKS**

**END**



**BLANK PAGE**



## List of data, formulae and relationships

### Data

Speed of light in vacuum	$c = 3.00 \times 10^8 \text{ m s}^{-1}$	
Gravitational constant	$G = 6.67 \times 10^{-11} \text{ N m}^2 \text{ kg}^{-2}$	
Acceleration of free fall	$g = 9.81 \text{ m s}^{-2}$	(close to the Earth)
Gravitational field strength	$g = 9.81 \text{ N kg}^{-1}$	(close to the Earth)
Elementary (proton) charge	$e = 1.60 \times 10^{-19} \text{ C}$	
Electronic mass	$m_e = 9.11 \times 10^{-31} \text{ kg}$	
Electronvolt	$1 \text{ eV} = 1.60 \times 10^{-19} \text{ J}$	
Planck constant	$h = 6.63 \times 10^{-34} \text{ J s}$	
Unified atomic mass unit	$u = 1.66 \times 10^{-27} \text{ kg}$	
Molar gas constant	$R = 8.31 \text{ J K}^{-1} \text{ mol}^{-1}$	
Permittivity of free space	$\epsilon_0 = 8.85 \times 10^{-12} \text{ F m}^{-1}$	
Coulomb law constant	$k = 1/4\pi\epsilon_0$ $= 8.99 \times 10^9 \text{ N m}^2 \text{ C}^{-2}$	
Permeability of free space	$\mu_0 = 4\pi \times 10^{-7} \text{ N A}^{-2}$	

### Rectilinear motion

For uniformly accelerated motion:

$$v = u + at$$

$$x = ut + \frac{1}{2}at^2$$

$$v^2 = u^2 + 2ax$$

### Forces and moments

Moment of  $F$  about  $O = F \times$  (Perpendicular distance from  $F$  to  $O$ )

Sum of clockwise moments about any point in a plane = Sum of anticlockwise moments about that point

### Dynamics

Force  $F = m \frac{\Delta v}{\Delta t} = \frac{\Delta p}{\Delta t}$

Impulse  $F\Delta t = \Delta p$

### Mechanical energy

Power  $P = Fv$

### Radioactive decay and the nuclear atom

Activity  $A = \lambda N$  (Decay constant  $\lambda$ )

Half-life  $\lambda_{\frac{1}{2}} = 0.69$



### Electrical current and potential difference

Electric current  $I = nAQv$

Electric power  $P = I^2R$

### Electrical circuits

Terminal potential difference  $V = \mathcal{E} - Ir$  (E.m.f.  $\mathcal{E}$ ; Internal resistance  $r$ )

Circuit e.m.f.  $\Sigma \mathcal{E} = \Sigma IR$

Resistors in series  $R = R_1 + R_2 + R_3$

Resistors in parallel  $\frac{1}{R} = \frac{1}{R_1} + \frac{1}{R_2} + \frac{1}{R_3}$

### Heating matter

Change of state: energy transfer =  $l\Delta m$  (Specific latent heat or specific enthalpy change  $l$ )

Heating and cooling: energy transfer =  $mc\Delta T$  (Specific heat capacity  $c$ ; Temperature change  $\Delta T$ )

Celsius temperature  $\theta/^\circ\text{C} = T/\text{K} - 273$

### Kinetic theory of matter

Temperature and energy  $T \propto$  Average kinetic energy of molecules

Kinetic theory  $p = \frac{1}{3}\rho\langle c^2 \rangle$

### Conservation of energy

Change of internal energy  $\Delta U = \Delta Q + \Delta W$  (Energy transferred thermally  $\Delta Q$ ; Work done on body  $\Delta W$ )

Efficiency of energy transfer =  $\frac{\text{Useful output}}{\text{Input}}$

Heat engine maximum efficiency =  $\frac{T_1 - T_2}{T_1}$

### Circular motion and oscillations

Angular speed  $\omega = \frac{\Delta\theta}{\Delta t} = \frac{v}{r}$  (Radius of circular path  $r$ )

Centripetal acceleration  $a = \frac{v^2}{r}$

Period  $T = \frac{1}{f} = \frac{2\pi}{\omega}$  (Frequency  $f$ )

Simple harmonic motion:

displacement  $x = x_0 \cos 2\pi ft$

maximum speed =  $2\pi fx_0$

acceleration  $a = -(2\pi f)^2 x$

For a simple pendulum  $T = 2\pi\sqrt{\frac{l}{g}}$

For a mass on a spring  $T = 2\pi\sqrt{\frac{m}{k}}$  (Spring constant  $k$ )



### Waves

Intensity  $I = \frac{P}{4\pi r^2}$  (Distance from point source  $r$ ;  
Power of source  $P$ )

### Superposition of waves

Two slit interference  $\lambda = \frac{xs}{D}$  (Wavelength  $\lambda$ ; Slit separation  $s$ ;  
Fringe width  $x$ ; Slits to screen distance  $D$ )

### Quantum phenomena

Photon model  $E = hf$  (Planck constant  $h$ )

Maximum energy of photoelectrons  $= hf - \phi$  (Work function  $\phi$ )

Energy levels  $hf = E_1 - E_2$

de Broglie wavelength  $\lambda = \frac{h}{p}$

### Observing the Universe

Doppler shift  $\frac{\Delta f}{f} = \frac{\Delta \lambda}{\lambda} \approx \frac{v}{c}$

Hubble law  $v = Hd$  (Hubble constant  $H$ )

### Gravitational fields

Gravitational field strength  $g = F/m$

for radial field  $g = Gm/r^2$ , numerically (Gravitational constant  $G$ )

### Electric fields

Electric field strength  $E = F/Q$

for radial field  $E = kQ/r^2$  (Coulomb law constant  $k$ )

for uniform field  $E = V/d$

For an electron in a vacuum tube  $e\Delta V = \Delta(\frac{1}{2}m_e v^2)$

### Capacitance

Energy stored  $W = \frac{1}{2}CV^2$

Capacitors in parallel  $C = C_1 + C_2 + C_3$

Capacitors in series  $\frac{1}{C} = \frac{1}{C_1} + \frac{1}{C_2} + \frac{1}{C_3}$

Time constant for capacitor discharge  $= RC$



### **Magnetic fields**

Force on a wire	$F = BIl$	
Magnetic flux density (Magnetic field strength)		
in a long solenoid	$B = \mu_0 nI$	(Permeability of free space $\mu_0$ )
near a long wire	$B = \mu_0 I / 2\pi r$	
Magnetic flux	$\Phi = BA$	
E.m.f. induced in a coil	$\mathcal{E} = -\frac{N\Delta\Phi}{\Delta t}$	(Number of turns $N$ )

### **Accelerators**

Mass-energy	$\Delta E = c^2 \Delta m$
Force on a moving charge	$F = BQv$

### **Analogies in physics**

Capacitor discharge	$Q = Q_0 e^{-t/RC}$
	$\frac{t_{\frac{1}{2}}}{RC} = \ln 2$
Radioactive decay	$N = N_0 e^{-\lambda t}$
	$\lambda t_{\frac{1}{2}} = \ln 2$

### **Experimental physics**

$$\text{Percentage uncertainty} = \frac{\text{Estimated uncertainty} \times 100\%}{\text{Average value}}$$

### **Mathematics**

	$\sin(90^\circ - \theta) = \cos \theta$	
	$\ln(x^n) = n \ln x$	
	$\ln(e^{kx}) = kx$	
Equation of a straight line	$y = mx + c$	
Surface area	cylinder = $2\pi r h + 2\pi r^2$	
	sphere = $4\pi r^2$	
Volume	cylinder = $\pi r^2 h$	
	sphere = $\frac{4}{3}\pi r^3$	
For small angles:	$\sin \theta \approx \tan \theta \approx \theta$	(in radians)
	$\cos \theta \approx 1$	





Paper Reference(s)

**6736/01**

**Edexcel GCE**

**Physics**

**Advanced Level**

**Unit Test PHY6: Synoptic Paper**

**Tuesday 17 June 2008 – Afternoon**

**Insert for use with Question 1.**

**This insert must NOT be returned  
to Edexcel with the question paper**

Printer's Log. No.

**M30414A**



W850/R6736/57570 7/6/6/5/5/1

This publication may be reproduced only in accordance with Edexcel Limited copyright policy. ©2008 Edexcel Limited.

*Turn over*

**edexcel**   
advancing learning, changing lives

## INSERT

This passage accompanies the question paper and forms an integral part of Question 1.

### Northern Lights: the *aurora borealis*

The northern lights is a natural phenomenon, visible in high latitudes, caused by the interaction of charged particles from the Sun with the Earth's atmosphere. Sunspots and solar flares emit charged particles, electrons and protons, that rush towards the Earth at very high speeds – between 0.2% and 0.6% of the speed of light. When the particles in this solar wind reach the Earth after two or three days, they cause disturbances in the Earth's magnetic field that can severely affect radio communication and radio navigation systems.

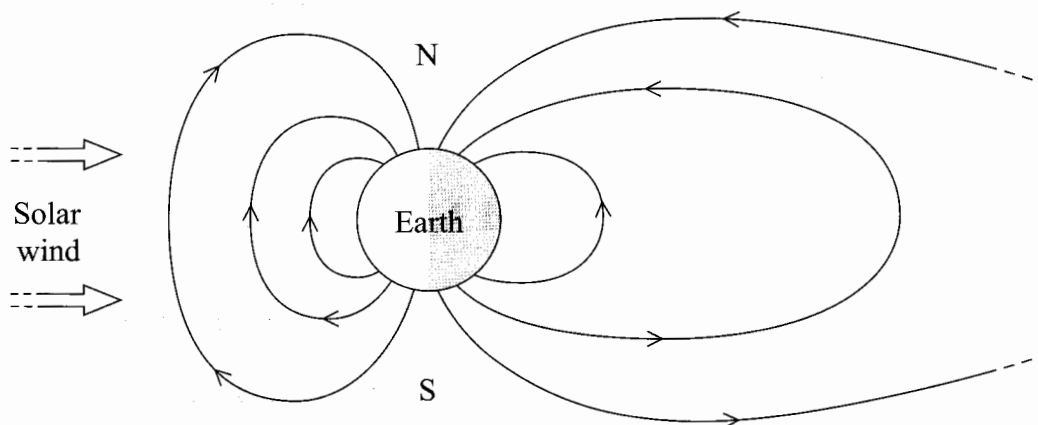

The solar wind causes the Earth's magnetic field (the magnetosphere) to form the shape shown in the diagram; a shape rather like that of a magnetic dipole, only distorted. The charged particles in the solar wind are deflected by this field and many of them subsequently find themselves trapped in the magnetosphere. Here they travel rapidly back-and-forth along a corkscrew-shaped spiral path whose centre is a magnetic field line running north-south, a few thousand kilometres above the Earth's surface. At the same time they drift slowly around the Earth, electrons and protons drifting in opposite directions.

As they approach the lower end of their trajectory near one of the Earth's magnetic poles the particles go into a flattening spiral and then wind back around the magnetic field line to the other pole where again they are 'reflected'. The transit from one pole to the other takes about a second. These magnetic reflections occur within 150 km or so of the Earth's surface, a height at which there is still a very, very thin atmosphere. Some of the charged particles collide there with atoms and molecules, ionising them, and it is the result of these ionisations that produces the dancing coloured lights that we call the aurora. The colours of the aurora depend on the elements present: oxygen produces a greenish hue while a red hue is the result of collisions with nitrogen molecules. A given proton or electron may continue to spiral back and forth, gradually losing energy in ionising collisions for several days.

Scientific study of the northern lights, which are most spectacular after there has been a magnetic storm on the surface of the Sun, takes place from research stations such as that at Poker Flat in Alaska. Here a camera captures spectacular images of the aurora and rockets are launched to collect data about the nature of the upper atmosphere. The more we know about the auroras and the solar wind, the more we will be able to predict the consequences for us of the magnetic storms on the Sun's surface.