



UNIVERSITY OF CAMBRIDGE INTERNATIONAL EXAMINATIONS
General Certificate of Education
Advanced Subsidiary Level and Advanced Level

PHYSICS

9702/32

Paper 3 Advanced Practical Skills 2

May/June 2013

CONFIDENTIAL INSTRUCTIONS



Great care should be taken to ensure that any confidential information given does not reach the candidates either directly or indirectly.

No access to the Question Paper is permitted in advance of the examination.

If you have any problems or queries regarding these Instructions, please contact Cambridge
by e-mail: info@cie.org.uk,
by phone: +44 1223 553554,
by fax: +44 1223 553558,
stating the Centre number, the nature of the query and the syllabus number quoted above.

This document consists of **7** printed pages and **1** blank page.



Preparing apparatus

These instructions detail the apparatus required for the experiments in the Question Paper. It is essential that absolute confidentiality is maintained in advance of the examination: the contents of these instructions must not be revealed either directly or indirectly to candidates.

No access is permitted to the Question Paper in advance of the examination.

If you have problems or queries regarding these instructions, please contact Cambridge:

by e-mail: info@cie.org.uk,
or by telephone: +44 1223 553554,
or by fax: +44 1223 553558,

stating the nature of the query and quoting the syllabus and paper numbers (9702/32).

It is assumed that the ordinary apparatus of a Physics laboratory will be available.

Number of sets of apparatus

The number of sets of apparatus provided for each experiment should be $\frac{1}{2}N$, where N is the number of candidates taking the examination. There should, in addition, be a few spare sets of apparatus available in case problems arise during the examination.

Organisation of the examination

Candidates should be allowed access to the apparatus for each experiment for one hour only. After spending one hour on one experiment, candidates should change over to the other experiment. The order in which a candidate attempts the two experiments is immaterial.

Assistance to Candidates

Candidates should be informed that, if they find themselves in real difficulty, they may ask the Supervisor for practical assistance, but that the extent of this assistance will be reported to the Examiner, who may make a deduction of marks.

Assistance should only be given:

when it is asked for by a candidate,
or as directed in the Notes sections of these instructions,
or where apparatus is seen to have developed a fault.

Assistance should be restricted to enabling candidates to make observations and measurements. Observations and measurements must not be made for candidates, and no help should be given with data analysis or evaluation.

All assistance given to candidates must be reported on the Supervisor's Report Form.

Faulty apparatus

In cases of faulty apparatus (not arising from a candidate's mishandling) that prevent the required measurements being taken, the Supervisor may allow extra time to give the candidate a fair opportunity to perform the experiment as if the fault had not been present. The candidate should use a spare copy of the Question Paper when the fault has been rectified or when working with a second set of apparatus.

Supervisor's Report

The Supervisor should complete the Supervisor's Report Form on pages 7 and 8 and enclose it in the envelope containing the answers of the candidates. If more than one envelope is used, a copy of the report must be enclosed in each envelope.

Question 1**Apparatus requirements (per set of apparatus unless otherwise specified)**

10 k Ω resistor fitted with terminals. Its value should be concealed and it should be labelled X. See Note 1.

Eight resistors with values 1.0 k Ω , 1.2 k Ω , 1.5 k Ω , 2.2 k Ω , 3.3 k Ω , 4.7 k Ω , 10.0 k Ω and 22.0 k Ω . Each should be labelled with its resistance value in k Ω to one decimal place. See Note 1.

2200 μ F capacitor rated at 16V or higher (e.g. RS components product code 707-6663). See Note 2 and Note 3.

6V d.c. power supply. See Note 3.

Switch. See Note 3.

Stopwatch reading to 0.1 s or better.

Digital voltmeter with a range of at least 10V and reading to 0.01V. If a multimeter is used, it should be fixed on this range and any unused terminals covered.

Eleven connecting leads.

Component holder with terminals and crocodile clips to hold a resistor.

Notes

- All resistors should be rated at 0.25W (e.g. RS components product code 707-7678 for the 1.2 k Ω value).
- The capacitor should be housed in a small box with two leads emerging. The box itself should be clearly labelled C.
- The power supply, capacitor and switch should be connected as shown in Fig. 1.1, with connections taped to discourage disconnection by the candidate. Supervisors should make sure that the polarity of the capacitor is correct, and that terminals are available as shown for the candidate to make further connections.

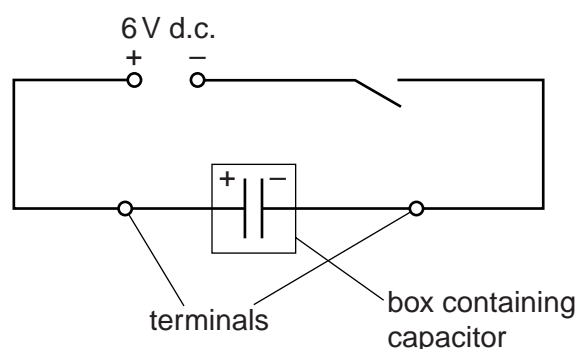
**Fig. 1.1**

- If the apparatus is to be used by a second candidate, then it should be returned to the state shown in Fig. 1.1. The remaining components should be disconnected and laid out on the bench, with all resistors removed from the component holder.

Information required by Examiners

Sample set of numerical results, clearly labelled "Supervisor's Results" and obtained out of sight of the candidates.

Question 2

Apparatus requirements (per set of apparatus unless otherwise specified)

Flexible plastic tube of length 50 cm and with an approximate inside diameter of 4 mm ('aquarium tube' in this size is suitable). The ends should be cut squarely. See Note 1.

Stiff wire of length 30 cm, e.g. steel wire of approximate diameter 1 mm or copper wire of approximate diameter 1.5 mm. See Note 1.

Plastic tube of length 1.5 cm and with an approximate inside diameter of 1.5 mm. Possible sources include the empty end of the ink tube from a ball-point pen, or the plastic insulation stripped from an electrical conductor. The ends should be cut squarely. See Note 1.

5 ml plastic syringe with a nozzle that fits tightly into the end of the 50 cm plastic tube. The graduations on the syringe should be at 0.1 or 0.2 ml intervals. See Note 1.

1 g of Blu-Tack. See Note 1.

One 100 g slotted mass and one 50 g slotted mass.

Vernier caliper (not a digital caliper).

Glass container (e.g. beaker) of minimum height 10 cm and minimum diameter 5 cm. See Note 2.

Paper towels.

Notes

1 Assemble the apparatus as shown in Fig. 2.1.

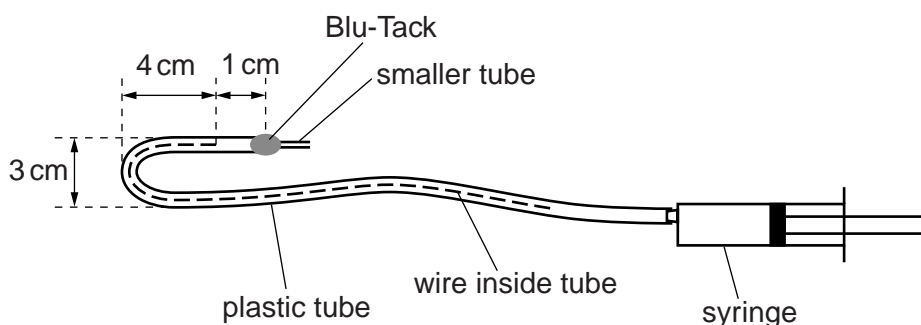

Fig. 2.1

The Blu-Tack should be used to form an airtight seal around the smaller tube but should not block the passage of air through the smaller tube.

- 2 Add water to the container until the level is 2 cm from the top.
- 3 Lay the apparatus out on the bench. If it is to be used by a second candidate, then it should be restored to its original state, ensuring that there is no water in the tube or syringe. If the smaller tube or Blu-Tack have been disturbed by the candidate, they should be reattached as shown in Note 1.

Information required by Examiners

Sample set of numerical results, clearly labelled "Supervisor's Results", and obtained out of sight of the candidates.

BLANK PAGE

Permission to reproduce items where third-party owned material protected by copyright is included has been sought and cleared where possible. Every reasonable effort has been made by the publisher (UCLES) to trace copyright holders, but if any items requiring clearance have unwittingly been included, the publisher will be pleased to make amends at the earliest possible opportunity.

University of Cambridge International Examinations is part of the Cambridge Assessment Group. Cambridge Assessment is the brand name of University of Cambridge Local Examinations Syndicate (UCLES), which is itself a department of the University of Cambridge.

This form should be completed and sent to the Examiner with the scripts.

SUPERVISOR'S REPORT FORM

General Certificate of Education Advanced Subsidiary Level and Advanced Level

May/June Session 2013

The Supervisor's Report should give full details of:

- (a) any help given to a candidate (including the nature of the help given and the name and candidate number of the candidate);
- (b) any cases of faulty apparatus (including the nature of the problem, the action taken to rectify it, any additional time allowed, and the name and candidate number of the candidate);
- (c) any accidents that occurred during the examination;
- (d) any other difficulties experienced by candidates, or any other information that is likely to assist the Examiner, especially if this information cannot be discovered in the scripts.

Cases of individual hardship, such as illness, bereavement or disability, should be reported direct to Cambridge on the normal Special Consideration form.

Information required by Examiners

For each question, please enclose a sample set of numerical results, obtained out of sight of the candidates and clearly labelled "Supervisor's Results".

Supervisor's Report



Supervisor's Report (continued)

Declaration

(to be signed by the Supervisor)

The preparation of this practical examination has been carried out so as to maintain fully the security of the examination.

Signed

Name

Centre number

Name of Centre

