



Rewarding Learning

ADVANCED
General Certificate of Education
2016

Centre Number

--	--	--	--	--

Candidate Number

--	--	--	--

Physics

Assessment Unit A2 3
Practical Techniques
Session 1



[AY231]

THURSDAY 5 MAY, MORNING

TIME

1 hour 30 minutes, plus your additional time allowance.

INSTRUCTIONS TO CANDIDATES

Write your Centre Number and Candidate Number in the spaces provided at the top of this page.

Turn to page 2 for further Instructions and Information.

For Examiner's use only		
Question Number	Marks	Remark
1		
2		
3		
Total Marks		

INSTRUCTIONS TO CANDIDATES

Answer **all** questions in this paper. Rough work and calculations must also be done in this paper. Except where instructed, do not describe the apparatus or experimental procedures. The supervisor will tell you the order in which you are to answer the questions. Not more than 30 minutes are to be spent in answering each question. You may be told to start with the experimental tests in Section A, or with the single question in Section B.

Section A consists of two experimental tests. A 28-minute period is allocated for you to use the apparatus. Two minutes are allocated to the supervisor to prepare the station for the next candidate. At the end of the 30-minute period you will be instructed to move to the area set aside for your next question. Section B consists of one question in which you will be tested on aspects of planning and design.

INFORMATION FOR CANDIDATES

The total mark for this paper is 60.

All questions carry 20 marks each.

Figures in brackets printed down the right-hand side of pages indicate the marks awarded to each part question.

You may use an electronic calculator.

Section A

- 1 In this experiment, two spring and string combinations, S_1 and S_2 , are suspended from a metre rule. You will investigate how the angle between S_1 and S_2 and the lengths of S_1 and S_2 change as the mass suspended from them is increased.

The aims of the experiment are:

- to measure the angle between S_1 and S_2 and the lengths of S_1 and S_2 as the mass, m , suspended from them is increased
- to plot a straight line graph
- to analyse the results and determine the value of a constant.

Apparatus

The apparatus has been set up for you as shown in **Fig. 1.1**. The distance between the points of suspension on the metre rule should not be adjusted.

A 100 g mass is suspended from S_1 and S_2 .

S_1 and S_2 have lengths l_1 and l_2 and the angle between S_1 and S_2 is θ .

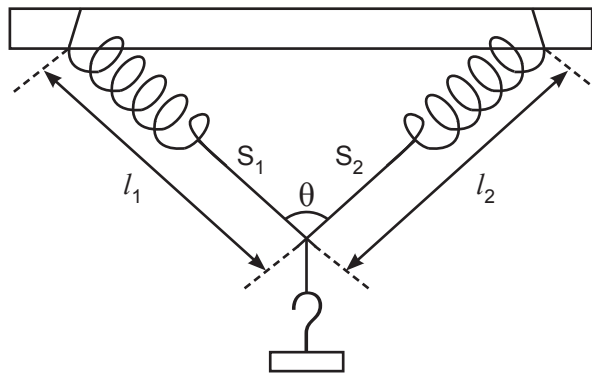

Fig. 1.1

Procedure

- (a) Measure the lengths l_1 and l_2 in centimetres, and the angle θ in degrees. Record your measurements in **Table 1.1**.

Repeat the procedure for **four** further masses up to a maximum mass of 500 g. Record all of your readings in the first four columns of **Table 1.1**. [5]

Table 1.1

m/g	$\theta/^\circ$	l_1/cm	l_2/cm	L/cm	$\frac{m}{\cos\left[\frac{\theta}{2}\right]}$ / —

- (b) (i) Calculate the average, L, of l_1 and l_2 to an appropriate number of significant figures, and record the values in the appropriate column of **Table 1.1**. [1]

Equation 1.1 describes the relationship between the variables L, m and θ

$$L = \frac{m}{2k \cos\left[\frac{\theta}{2}\right]} + P \quad \text{Equation 1.1}$$

where P and k are constants.

- (ii) Calculate values for $\frac{m}{\cos\left[\frac{\theta}{2}\right]}$ to 3 significant figures and insert these values into the appropriate column of **Table 1.1**. Include the unit in the column heading. [3]

Examiner Only	
Marks	Remark

(iii) Draw a graph of L against $\frac{m}{\cos\left[\frac{\theta}{2}\right]}$ on the grid of **Fig. 1.2**.

Choose suitable scales, plot the points and draw the best fit straight line.

[5]

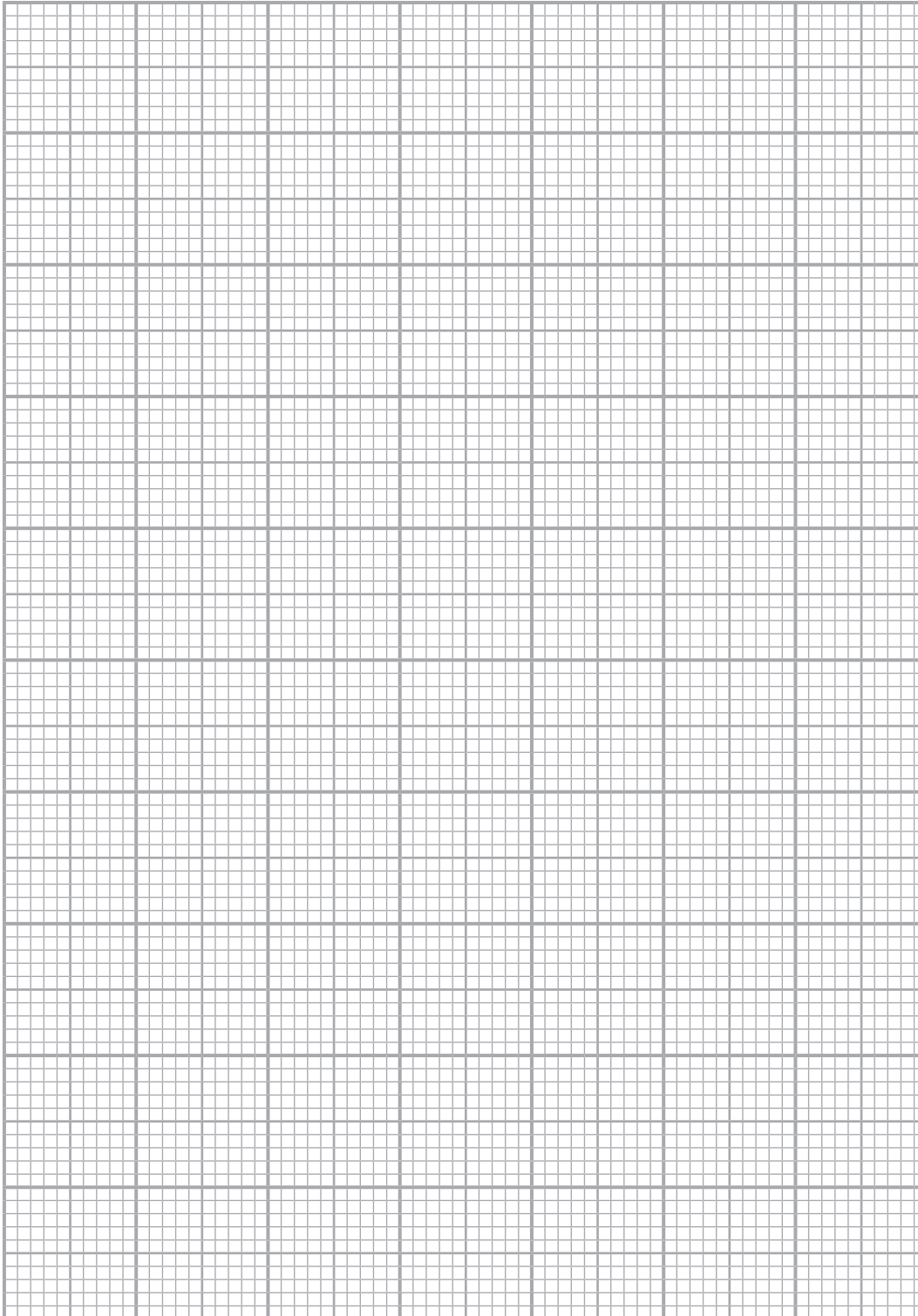

Fig. 1.2

Examiner Only	
Marks	Remark

(c) (i) Calculate the gradient of the graph and state the unit of the gradient.

Gradient = _____

Unit of gradient = _____

[3]

(ii) Use your answer to (c)(i) to determine a value for k .

k = _____ unit

[2]

(iii) By considering **Equation 1.1**, deduce what the constant P represents.

_____ [1]

Examiner Only

Marks

Remark

- 2 In this experiment you will investigate how the intensity of light incident on a light dependent resistor (LDR) varies with the thickness of the glass through which the light is transmitted.

The aims of the experiment are:

- to measure the current through the LDR*
- to plot a graph to find the relationship between the current through the LDR and the thickness of glass through which the light is transmitted.

* The current through the LDR changes in proportion to the light intensity incident on the LDR.

Apparatus

- (a) The apparatus has been set up for you as shown in **Fig. 2.1**. There is a single microscope slide between the bulb and the LDR.

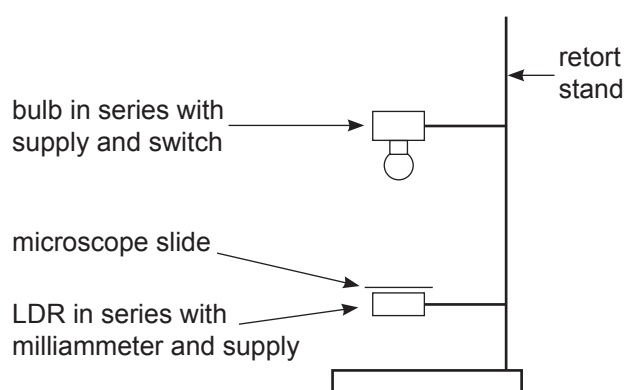

Fig. 2.1

Procedure

Close the switch and read the current, I , from the milliammeter.
Record your value in **Table 2.1** for number of slides, $N = 1$.

Repeat the procedure, adding microscope slides one at a time, up to a maximum of 5 slides. Record all of your measurements of current in **Table 2.1**. [3]

Table 2.1

N	I/mA	
1		
2		
3		
4		
5		

- (b) The relationship between the current, I , and the number of microscope slides, N , is given by **Equation 2.1**

$$I = I_0 e^{-PN} \quad \text{Equation 2.1}$$

where P and I_0 are constants.

- (i) Show that a graph of natural logarithm, $\ln I$, against N will result in a straight line graph from which values of I_0 and P can be determined.

[2]

- (ii) Calculate values for $\ln I$ to 2 decimal places and insert them into the remaining column of **Table 2.1**. Write an appropriate heading for this column in **Table 2.1**. [2]

Examiner Only

Marks Remark

(iii) Plot a graph of $\ln I$ against N on the grid of **Fig. 2.2** and draw a best fit straight line through the points. The N axis has been labelled and scaled.

[5]

Examiner Only	
Marks	Remark

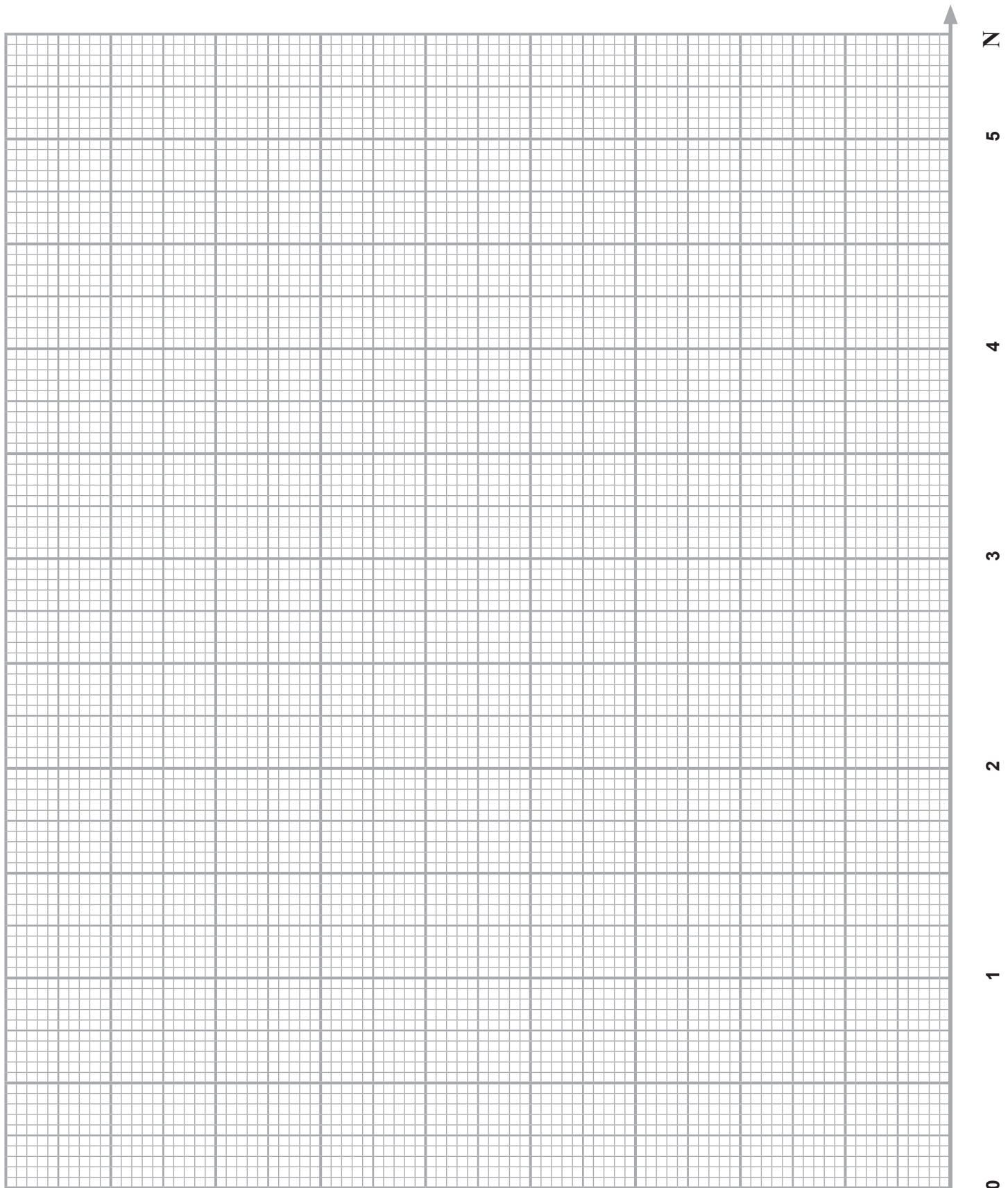

Fig. 2.2

(c) (i) Use your graph to calculate a value for constant P .

$P = \underline{\hspace{2cm}}$ [2]

(ii) Use your graph to calculate a value for constant I_0 . Determine the absolute uncertainty in your value for I_0 .

$I_0 = \underline{\hspace{2cm}}$ mA \pm $\underline{\hspace{2cm}}$ mA [5]

(iii) On **Fig. 2.2**, sketch a graph that you would expect to obtain if a brighter bulb was used. [1]

Examiner Only	
Marks	Remark

BLANK PAGE

(Questions continue overleaf)

Section B

- 3 In this question you will plan an experiment to determine the radius of curvature of a bowl by measuring the period of oscillation, T , of a ball bearing as it oscillates in the bowl.

Fig. 3.1 shows a side view of the experimental arrangement.



Fig. 3.1

The period of oscillation of a ball bearing in the bowl is given by **Equation 3.1**

$$T = 2\pi\sqrt{\frac{7(R-r)}{5g}} \quad \text{Equation 3.1}$$

where R is the radius of curvature of the bowl, r is the radius of the ball bearing and g is the acceleration of free fall.

- (a) In order to check the validity of **Equation 3.1**, a student is given a bowl of radius of curvature 8.6 ± 0.1 cm. The student found the period of oscillation of a ball bearing to be 0.66 ± 0.05 s.

The ball bearing has a radius of 0.76 ± 0.01 cm.

- (i) Use the student's results to calculate a value for the acceleration of free fall.

Examiner Only	
Marks	Remark

$g =$ _____ m s^{-2}

[2]

(ii) Calculate the percentage uncertainty in the value of $(R - r)$.

Uncertainty = \pm _____ %

[2]

(iii) Calculate the absolute uncertainty in the value of g .

Uncertainty = \pm _____ ms^{-2}

[4]

(b) (i) **Equation 3.1** can be written as **Equation 3.2**. Calculate a numerical value for the constant k and give the unit of k .

$$T^2 = kR - kr \quad \textbf{Equation 3.2}$$

$k =$ _____

Unit of $k =$ _____

[3]

Examiner Only

Marks Remark

[9]

Examiner Only	
Marks	Remark

THIS IS THE END OF THE QUESTION PAPER

Permission to reproduce all copyright material has been applied for.
In some cases, efforts to contact copyright holders may have been unsuccessful and CCEA
will be happy to rectify any omissions of acknowledgement in future if notified.