



Centre Number

71	
----	--

Candidate Number

--

ADVANCED SUBSIDIARY (AS)
General Certificate of Education
2013

Physics

Assessment Unit AS 3

assessing

Practical Techniques (Internal Assessment)

Session 1

[AY131]

TUESDAY 14 MAY, MORNING

MV18

TIME

1 hour 30 minutes, plus your additional time allowance.

INSTRUCTIONS TO CANDIDATES

Write your Centre Number and Candidate Number in the spaces provided at the top of this page.

Turn to page 2 for further Instructions and Information.

INSTRUCTIONS TO CANDIDATES

Answer **all** the questions in this booklet. Rough work and calculations must also be done in this booklet. Except where instructed, do **not** describe the apparatus or experimental procedures. The Teacher/Supervisor will tell you the order in which you are to answer the questions.

One hour is to be spent on Section A and 30 minutes on Section B, plus your additional time allowance on each section. Section A consists of four short experimental tests. **You will have access to the apparatus for 13 minutes for each of the tests.** At the end of this 13-minute experimental period there is a 2-minute changeover to the area set aside for the next test. Any spare time before the start of the next test may be used to write up anything you have not yet completed.

At the end of your Section A work you will be told to move to the area set aside for Section B. Section B consists of one question in which you will analyse a set of experimental results.

INFORMATION FOR CANDIDATES

The total mark for this paper is 40.

Section A and Section B carry 20 marks each.

Figures in brackets printed at the end of each question indicate the marks awarded to each part question.

You may use an electronic calculator.

BLANK PAGE

(Questions start overleaf)

Section A

1 In this experiment you are to investigate how the period of oscillation of a chain of paperclips varies as the distance y , shown in **Fig. 1.1**, is changed.

(a) The apparatus in **Fig. 1.1** has been set up for you. Measure the distance y and record the value in **Table 1.1** opposite.

When the paperclip chain is displaced slightly in a plane perpendicular to the metre rule it will oscillate as shown in the side view.

Fig. 1.1

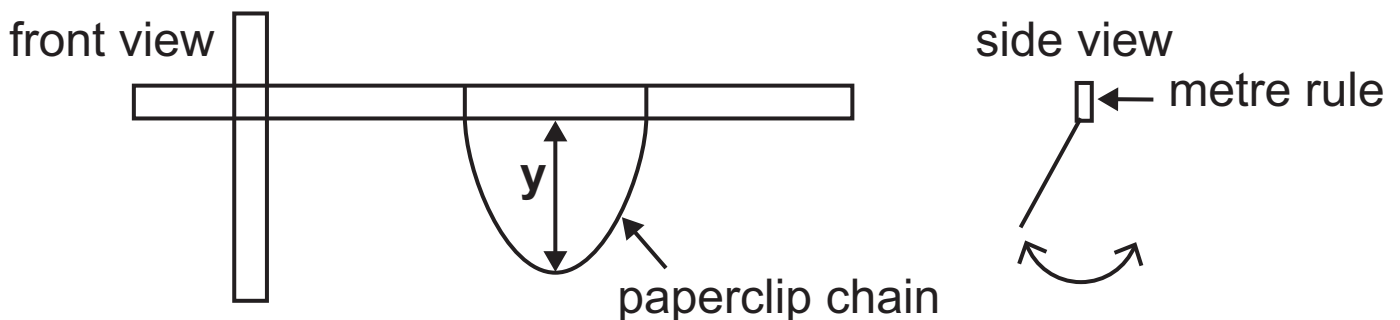

Displace the chain a small distance horizontally and allow it to oscillate. Take readings to allow you to determine T , the period of oscillation, by measuring and recording the time for 10 oscillations. Record all your results in **Table 1.1**. [2]

Adjust y by sliding the loops of string along the metre rule so that y is half of its initial value and repeat the above procedure.

Table 1.1

y/mm	Time for 10 oscillations/s	T/s

(b) (i) Without calculation, how can you tell from your results in **Table 1.1** that **y** and **T** are not inversely proportional? [1]

(ii) Carry out calculations using the results in **Table 1.1** to determine whether or not **y** and **T** are proportional. Explain your answer.

Is **T** proportional to **y**?

Yes No

Explanation: [2]

2 In this experiment you will take measurements to enable you to calculate the area of an A4 sheet of paper and find the associated uncertainty in your answer.

(a) Use the ruler provided to measure the length and breadth of the blank A4 page provided. State the uncertainty in each of your measurements. [1]

Length = _____ \pm _____ cm

Breadth = _____ \pm _____ cm

(b) Calculate the area of the sheet of paper, and the uncertainty in your value of area. Show all of your working out clearly. [3]

Area = _____ \pm _____ cm²

(c) In order to calculate the volume of the sheet of paper the thickness of the sheet would also be required. Describe how you would measure the thickness of the paper to ensure an accurate value. [1]

- 3 In this experiment you will take measurements of current and potential difference to enable you to work out the internal resistance of a power supply. You are provided with the circuit shown in **Fig. 3.1**. The resistor R in the circuit initially has a value of $10\ \Omega$.

Fig. 3.1

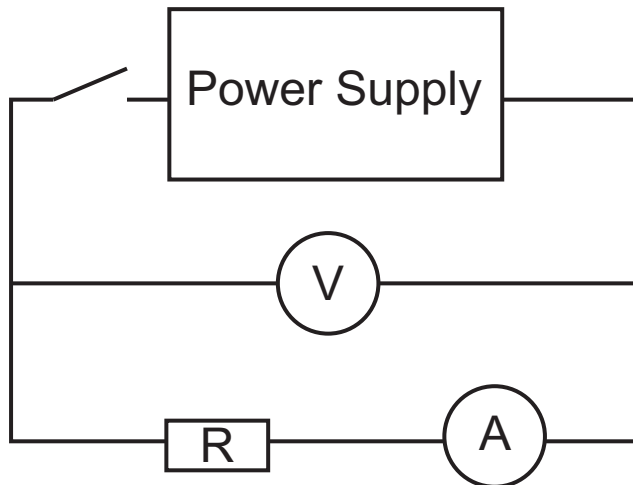

- (a) Close the switch and record values in **Table 3.1** opposite for the current in the circuit and the potential difference across the supply. Replace R with the resistor of value $22\ \Omega$ and repeat the procedure. Finally, replace this resistor with the $47\ \Omega$ resistor and again repeat the procedure. Record all the results in **Table 3.1**. [1]

Table 3.1

Resistance/ Ω	Current/A	Voltage/V	Power/W
10			
22			
47			

(b) Calculate the power dissipated in the resistor in each case and use the final column of **Table 3.1** to record the values. [1]

(c) The power reaches a maximum value when the resistance, R is equal to the internal resistance of the supply. Which value of resistance from **Table 3.1** is closest to the internal resistance of the supply? Describe how you could find a more accurate value for the internal resistance of the supply. [3]

- 4 In this experiment you will take measurements to allow you to calculate a value for the resistivity of a metal.

The multimeter has been set to allow you to measure the resistance of the sample of metal wire directly.

Do not adjust the position of the crocodile clips on the wire.

(a) The following measurements will be required to calculate the resistivity. Record these in **Table 4.1**. [2]

- The resistance of the wire from the multimeter.
- The diameter of the metal wire using the micrometer screw gauge.
- The length of the wire between the crocodile clips.

Table 4.1

Measurement	Value			Unit
Resistance				Ω
Diameter			Average	
Length			Average	

(b) Use the values in **Table 4.1** and the equation

$R = \frac{\rho l}{A}$ to calculate the resistivity of the sample of wire. [3]

Resistivity = _____ Ω m

Section B

Water Waves

5 An experiment was carried out to investigate how the speed of a wave, v , travelling through deep water depends on the wavelength of the wave, λ . The times, t , for waves to travel a distance of **5.00 m** were measured and the results recorded in **Table 5.1**.

(a) Calculate the speed of the wave for each wavelength and record your values to an appropriate number of significant figures in the third column of **Table 5.1**. [2]

Table 5.1

λ/m	t/s	$v/\text{m s}^{-1}$	
0.45	5.97		
0.70	4.78		
0.95	4.14		
1.20	3.73		
1.45	3.31		

(b) The relationship between v and λ is given by **Equation 5.1** where P is a constant.

Equation 5.1

$$v = \sqrt{\frac{P\lambda}{2\pi}}$$

(i) Use **Equation 5.1** to show that a graph of v^2 plotted against λ will result in a straight line graph **that will go through the origin**. [2]

(ii) There are alternative plots to that suggested in (b)(i) that would also result in a straight line graph being obtained. Suggest one alternative that would result in a straight line graph being obtained. [1]

y-axis: _____ x-axis: _____

Data Processing

- (c) (i) Head the blank column of **Table 5.1** with the quantity that needs to be calculated to draw the graph in **(b)(i)**, **not your alternative suggestion**. Include the appropriate unit. [1]
- (ii) Calculate the numerical values needed to complete the blank column in **Table 5.1**. [2]
- (iii) On the grid of **Fig. 5.1** opposite, draw the graph given in **(b)(i)** using the processed data in **Table 5.1**. Label the axes and choose suitable scales. Plot the points and draw the best fit straight line. [5]

Fig. 5.1

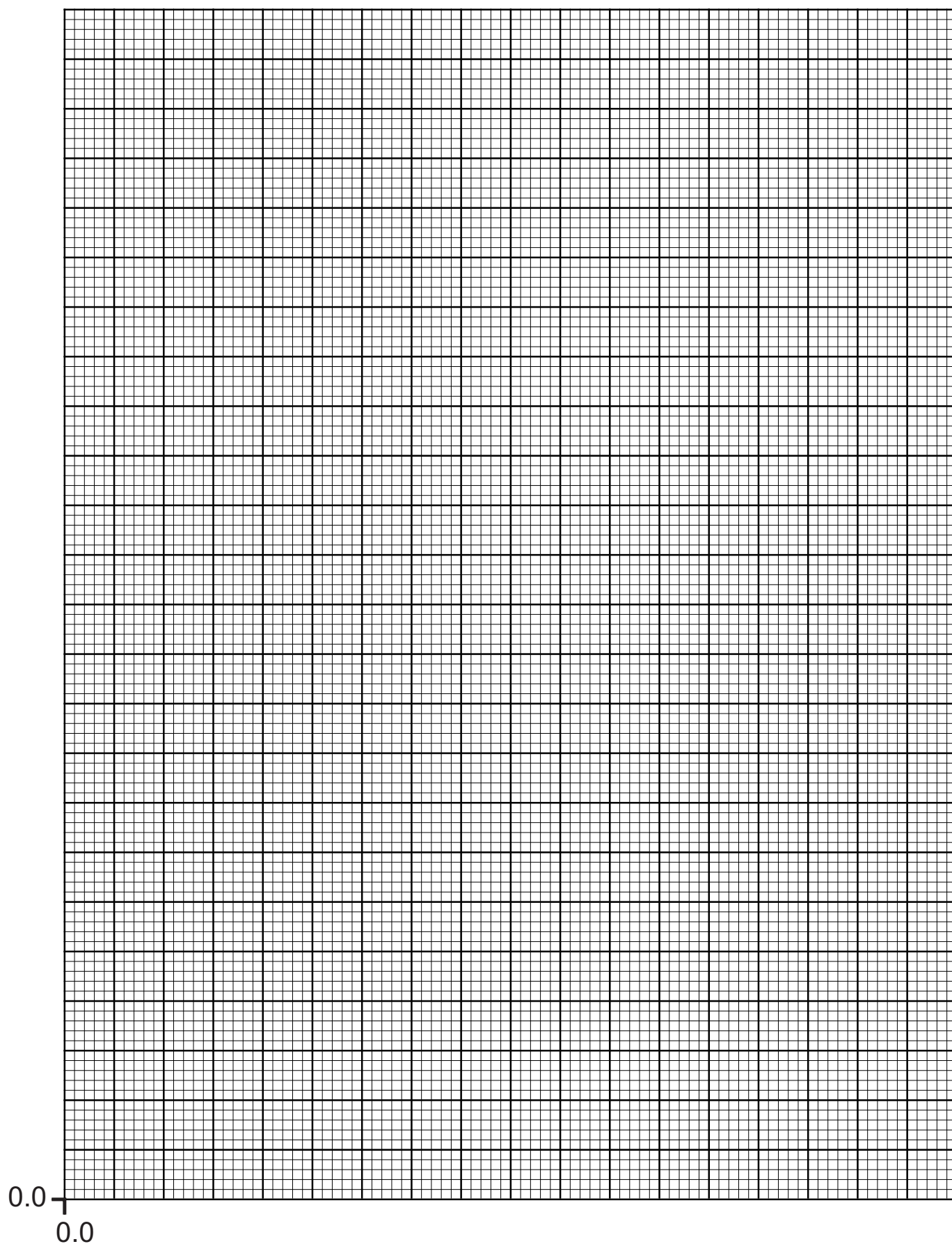

Analysis

(d) (i) Determine the gradient of the graph. [3]

Gradient = _____

Units of gradient = _____

(ii) Use your value for the gradient to calculate a value for P . [2]

P = _____

(e) In shallow water the relationship between v and λ is given by **Equation 5.2**.

Equation 5.2

$$v = \sqrt{P\lambda}$$

On the grid of **Fig. 5.1** draw a line to show the graph that would have been obtained if the experiment had been carried out in shallow water instead of in deep water, label this line **S**. Use your value of **P** and the space below for any necessary calculations. [2]

THIS IS THE END OF THE QUESTION PAPER

Question Number	Marks		Remark
	Teacher Mark	Examiner Check	
1			
2			
3			
4			
5			
Total Marks			

Permission to reproduce all copyright material has been applied for.
 In some cases, efforts to contact copyright holders may have been unsuccessful and CCEA will be happy to rectify any omissions of acknowledgement in future if notified.