



Centre Number

71	
----	--

Candidate Number

--

ADVANCED  
General Certificate of Education  
2013

---

## Physics

Assessment Unit A2 3  
Practical Techniques  
(Internal Assessment)  
Session 1

[AY231]

THURSDAY 9 MAY, MORNING

---

MV18

### TIME

1 hour 30 minutes, plus your additional time allowance.

### INSTRUCTIONS TO CANDIDATES

Write your Centre Number and Candidate Number in the spaces provided at the top of this page.

Turn to page 2 for further Instructions and Information.

## INSTRUCTIONS TO CANDIDATES

Answer **all** questions in this paper. Rough work and calculations must also be done in this paper. Except where instructed, do not describe the apparatus or experimental procedures.

The supervisor will tell you the order in which you are to answer the questions. Not more than 30 minutes are to be spent in answering each question. You may be told to start with the experimental tests in Section A, or with the single question in Section B.

Section A consists of two experimental tests. A 28-minute period is allocated for you to use the apparatus. Two minutes is allocated to the supervisor to prepare the station for the next candidate. At the end of the 30-minute period you will be instructed to move to the area set aside for your next question. Section B consists of one question in which you will be tested on aspects of planning and design. Timings may be longer if you have additional time allowance.

## INFORMATION FOR CANDIDATES

The total mark for this paper is 60.

All questions carry 20 marks each.

You are provided with **two** inserts, **Fig. 1.3** and **Fig. 2.2**.

Figures in brackets printed at the end of each question indicate the marks awarded to each part question.

You may use an electronic calculator.

**BLANK PAGE**

**(Questions start overleaf)**

## Section A

- 1 In this experiment you will use both a converging lens and a diverging lens to focus images of an object onto a screen in order to determine the focal length of the diverging lens.

The aims of this experiment are:

- to verify that the focal length of the converging lens is 0.2 m;
- to obtain focused images of the object and take measurements from an optical bench arrangement;
- to use the results to plot a linear graph; and
- to use the graph to determine the focal length of the diverging lens.

- (a) You are provided with an illuminated object, a converging lens in a holder, a screen and a metre rule, arranged as shown in **Fig. 1.1**. The illuminated object consists of two crossed lines with a flat circular ring. The lines are to assist focusing.

**Fig. 1.1**

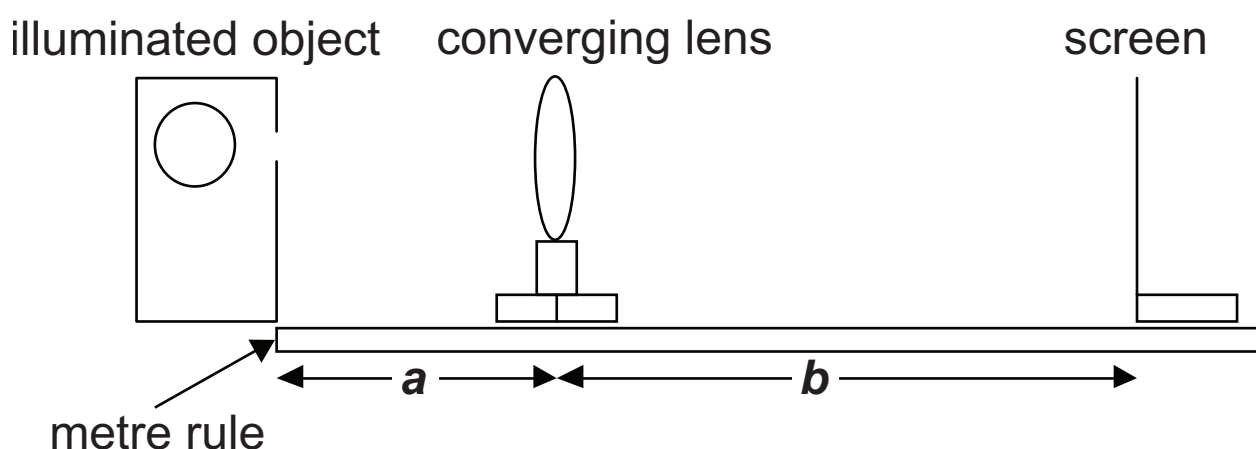

- (i) For the three object distances, **a**, given in **Table 1.1**, adjust the position of the screen to obtain a sharply focused image. Measure the corresponding image distance, **b**, for each **a** value. Record your values in **Table 1.1**. [3]

**Table 1.1**

<b>a/cm</b>	<b>b/cm</b>
35	
40	
45	

- (ii) Calculate a reliable value for the focal length,  $f_1$ , of the converging lens by using **Equation 1.1** and the data from **Table 1.1**. [2]

**Equation 1.1**

$$\frac{1}{f_1} = \frac{1}{a} + \frac{1}{b}$$

Focal length = \_\_\_\_\_ cm

- (iii) Explain whether or not your calculated focal length verifies that the focal length of the converging lens is 0.2 m. [1]
- 
-

(b) A diverging lens is introduced. Alter the optical bench arrangement of **Fig. 1.1** so that you have the arrangement shown in **Fig. 1.2**. **The converging lens must be placed 50.0 cm from the illuminated object and not moved from this position.**

**Fig. 1.2**

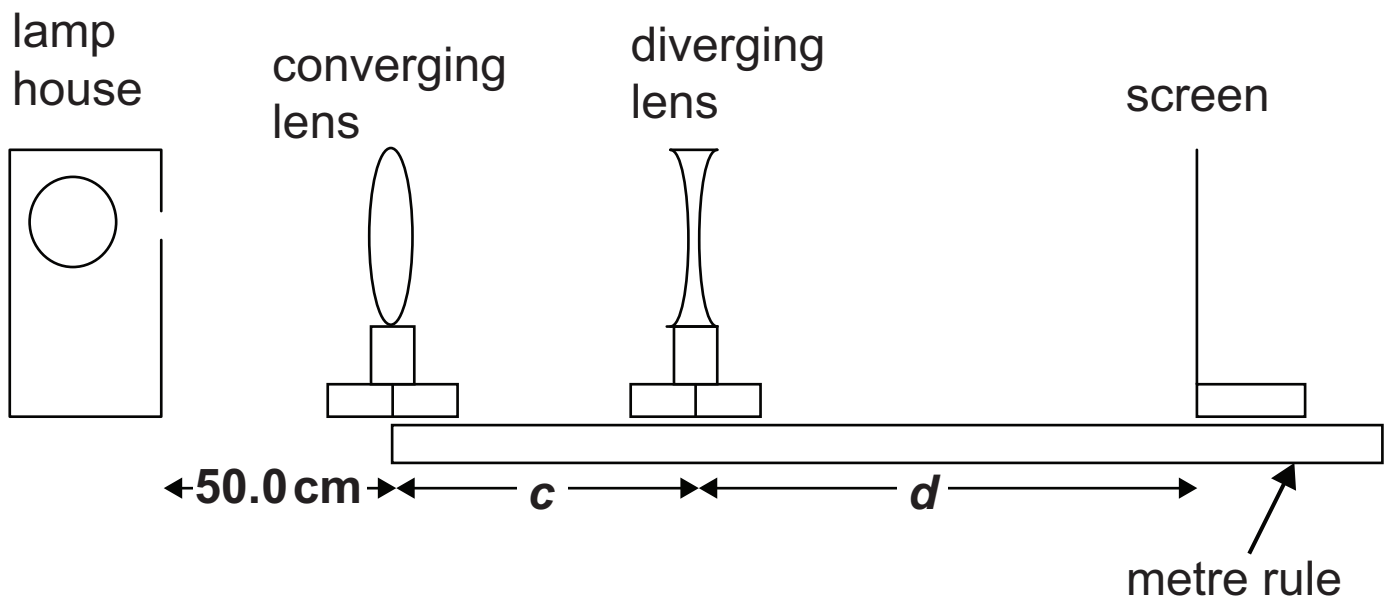

**With the converging lens 50.0 cm from the illuminated object,** re-position the metre rule so that the zero position corresponds to the converging lens position. Place the diverging lens at each distance  $c$ , listed in **Table 1.2**. Distance,  $c$  is the distance between the converging and diverging lenses. Adjust the position of the screen until a clearly focused image is obtained. Now record the distance  $d$ , the distance between the screen and the diverging lens. [3]

**Table 1.2**

Distance $c/cm$	Distance $d/cm$	$\left[\left(\frac{d+c-33}{d}\right)\right]$
26		
25		
24		
23		
22		

(c) The relationship between the distances  $c$  and  $d$  is given by **Equation 1.2**.

**Equation 1.2**

$$c = f_2 \left( \frac{d+c-33}{d} \right) + 33$$

where  $f_2$  is the focal length of the diverging lens.

(i) In the space below, use **Equation 1.2** to show what the gradient and y-intercept will be if  $c$  is plotted on the y-axis and  $\left(\frac{d+c-33}{d}\right)$  is plotted on the x-axis.

Gradient = \_\_\_\_\_

Intercept = \_\_\_\_\_ [2]

(ii) Complete **Table 1.2** by calculating the values for

$$\left( \frac{d+c-33}{d} \right)$$

Insert values that are correct to **two** significant figures. [2]

(iii) On the graph grid of **Fig. 1.3** (supplied as an Insert), choose a suitable scale for the horizontal axis, plot the points and draw the best-fit line. [4]

(d) Use your graph to determine the value for the focal length,  $f_2$ , of the diverging lens. [3]

$f_2 =$  \_\_\_\_\_ cm



- 2 In this experiment you will use a stopwatch to measure the time taken for the voltage across a capacitor to decay in order to determine the capacitance of the capacitor.

The aims of this experiment are:

- to determine the resistance of a resistor;
- to record the capacitor voltage as it discharges;
- to use the results to plot a linear graph; and
- to use the graph to determine the capacitance of the capacitor.

(a) You are provided with a mounted resistor, a voltmeter, a **microammeter**, a power supply unit and some connecting wires. For **three** different settings on the power supply unit determine a **reliable** value for the resistance of the mounted resistor using the ammeter-voltmeter method. Tabulate your results in the space below. [3]

Average resistance = \_\_\_\_\_  $\Omega$

(b) An identical resistor to that used in (a) has been placed in series with a capacitor in the circuit provided. The arrangement is shown in **Fig. 2.1**. The switch will allow the capacitor to be charged from the power supply unit when in position C and discharged through the resistor when in position D.

**Fig. 2.1**

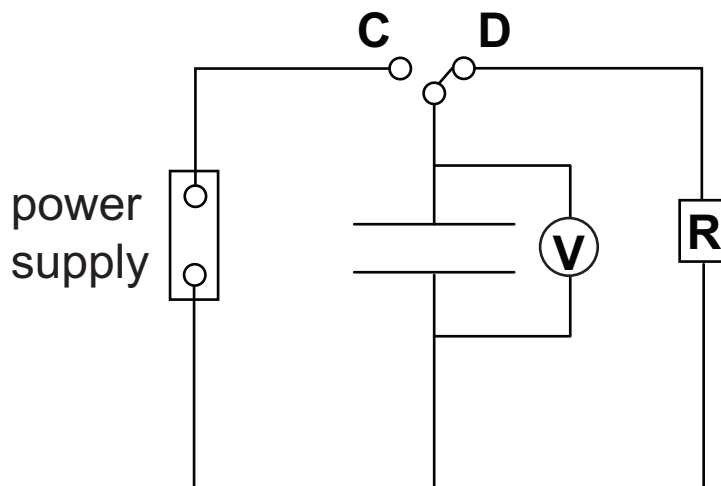

Set the switch to the charge position C for a few seconds. Then set the switch to the discharge position D and at the same time begin timing. You are to take a series of discharge voltage  $V_d$  readings at 10 second intervals for 90 seconds. Record your results in **Table 2.1**. [2]

**Table 2.1**

$t/s$	$V_d/V$	
0		
10		
20		
30		
40		
50		
60		
70		
80		
90		

- (c) (i) In order to obtain a linear graph it is necessary to obtain the natural logarithm ( $\ln$ ) of the discharge voltage,  $V_d$ . In the right hand column of **Table 2.1**, insert the title for the column and the corresponding natural logarithm values. [2]
- (ii) On the grid of **Fig. 2.2** (supplied as an Insert) you will plot the natural logarithm of the discharge voltage on the y-axis and time on the x-axis. [5]

- (d) (i) The mathematical relationship for this experiment is given by **Equation 2.1**.

**Equation 2.1**

$$V_d = V_0 e^{-t/CR}$$

Explain how the gradient of the graph you have drawn equals  $-\frac{1}{CR}$ . [2]

- (ii) Use your results to determine a value for  $C$ , the capacitance of the capacitor.  
N.B.  $R$  is the value obtained in (a). [3]

Capacitance = \_\_\_\_\_ F

(iii) Use the graph to obtain a value for  $V_0$ , the initial voltage. [3]

$$V_0 = \text{_____} \text{ V}$$

## Section B

- 3 In this exercise you are to plan and analyse two distinct methods for determining the mass per unit length  $\mu$  of a string. **Equation 3.1** defines mass per unit length,  $\mu$ .

### Equation 3.1

$$\mu = \frac{m}{l}$$

where  $m$  is the mass and  $l$  the length.

### Method 1: Direct measurement

- (a) Direct measurements of the string provide the following data:

The total length of the string is 92.4 cm and it has a mass of 5.83 g.

- (i) The length was measured using a metre rule. State the absolute uncertainty in this measurement and explain how you arrived at your answer. [2]

Absolute uncertainty =  $\pm$  \_\_\_\_\_

---

---

---

Five balances are available for measuring the mass. **Table 3.1** provides information about the balances.

**Table 3.1**

Balance	Range	Precision	Analogue or Digital	
A	0 g–100 g	$\pm 1$ g	Analogue	Spring balance
B	0 g–20 g	$\pm 0.1$ g	Analogue	Spring balance
C	0 g–4100 g	$\pm 0.1$ g	Digital	Top-pan balance
D	0 g–2000 g	$\pm 0.01$ g	Digital	Top-pan balance
E	0 g–210 g	$\pm 0.1$ mg	Digital	Top-pan balance

(ii) On which balance was the measurement of mass made? Explain your answer. [2]

---

---

---

(iii) Calculate the mass per unit length,  $\mu$ , in  $\text{kg m}^{-1}$  quoting your answer to the correct number of significant figures, and state the percentage uncertainty in your value. [4]

$$\mu = \text{_____} \text{ kg m}^{-1}$$

$$\text{Uncertainty} = \text{_____} \%$$



**BLANK PAGE**

**(Questions continue overleaf)**

## Method 2: Indirect measurement using standing waves

(b) The velocity,  $v$ , of a transverse wave along a stretched string is given by **Equation 3.2**

### Equation 3.2

$$v = \sqrt{\frac{T}{\mu}}$$

where  $T$  is the tension in the string and  $\mu$  is the mass per unit length.

One end of the string is attached to a vibrator and the other end is attached to a slotted mass hanger. The vibrator oscillates producing transverse waves in the string, with a frequency given by the signal generator to which it is connected. The string is looped over a pulley and the slotted masses hang freely, as shown in **Fig. 3.1**. At certain frequencies of vibration resonance is established and standing waves are set up on the string.

**Fig. 3.1**

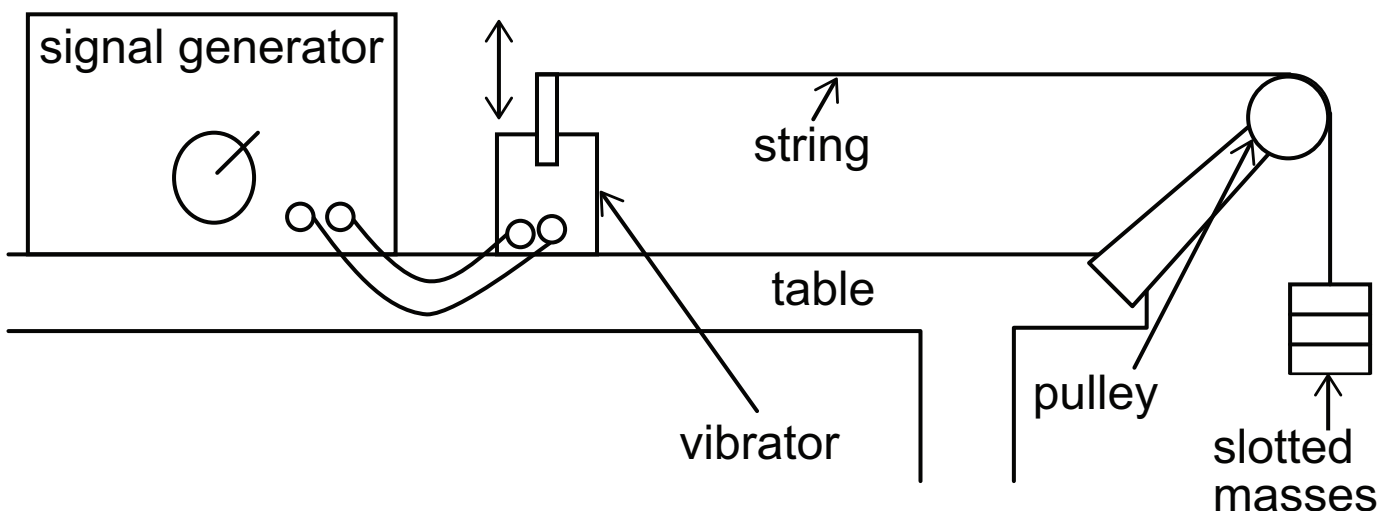

- (i) Explain how a value for the tension is determined in the arrangement shown in **Fig. 3.1**. [2]

---

---

---

---

When the **first position of resonance** (the **fundamental**) of the standing wave exists on the string, the velocity of the transverse wave can be determined using **Equation 3.3**.

**Equation 3.3**

$$v = 2fl$$

where  $f$  is the frequency of the wave and  $l$  is the length of the vibrating string.

- (ii) Using standing wave theory for the first position of resonance, derive **Equation 3.3**. [2]

- (iii) On **Fig. 3.1**, clearly identify the length,  $l$ , that should be measured. [1]

(iv) Describe how you would use the apparatus in **Fig. 3.1** to obtain the wave velocity for a particular string tension. [2]

---

---

---

---

---

---

---

(v) The frequency value from the signal generator dial lacks precision. An alternative method by which the frequency could be determined is the use of a cathode ray oscilloscope (CRO). Explain how the CRO is used to determine frequency. [2]

---

---

---

---

---

(vi) Assume five pairs of values of wave velocity and the corresponding string tension are available. Describe how you would analyse these results graphically to obtain a value for the mass per unit length. [3]

---

---

---

---

---

---

**THIS IS THE END OF THE QUESTION PAPER**

---





Question Number	Marks		
	Teacher Mark	Examiner Check	Remark
1			
2			
3			
<b>Total Marks</b>			

Permission to reproduce all copyright material has been applied for.  
 In some cases, efforts to contact copyright holders may have been unsuccessful and CCEA will be happy to rectify any omissions of acknowledgement in future if notified.



Insert: **Fig 1.3** to be used with Question 1.

8193.04 MV18

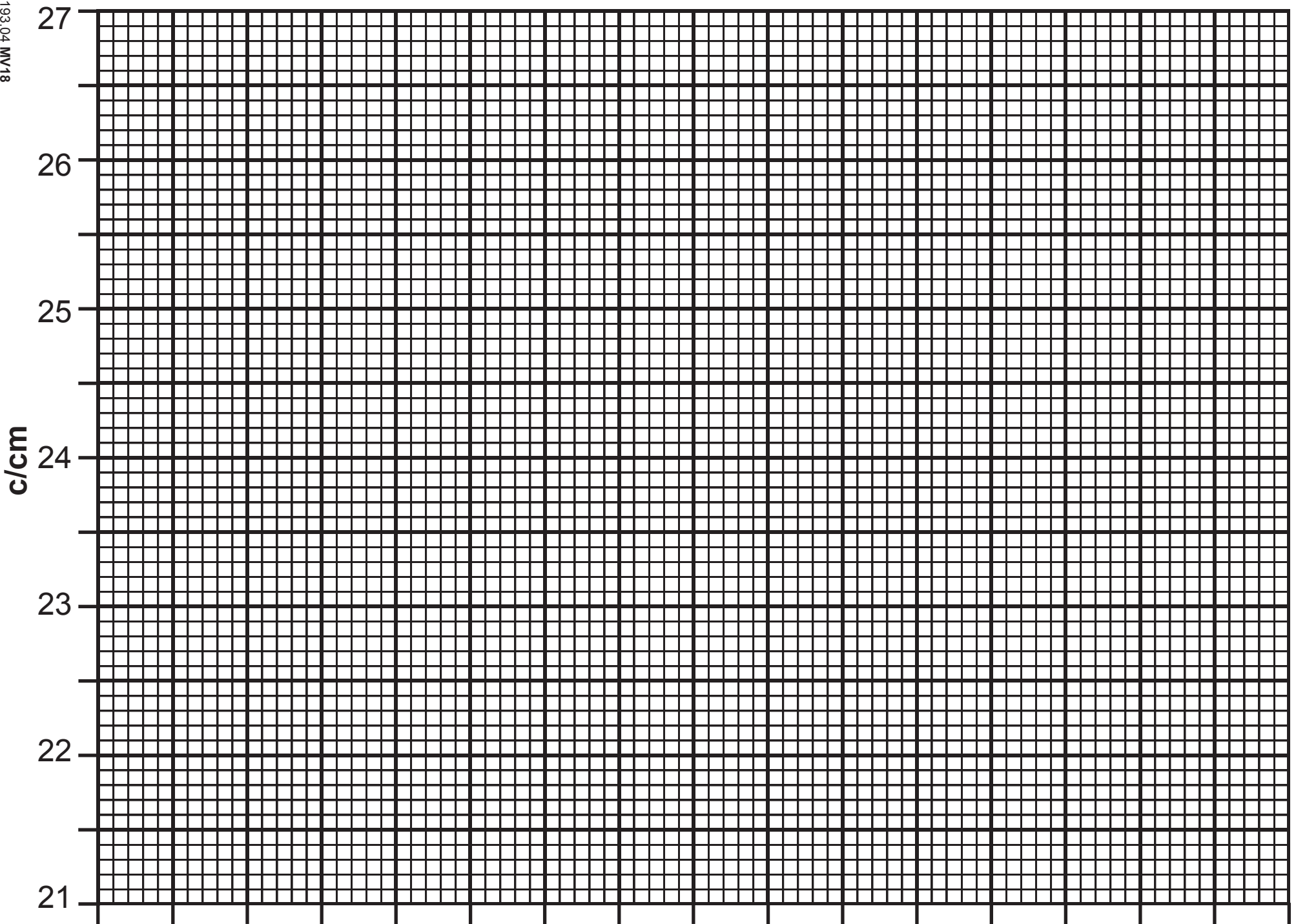

Insert: **Fig 2.2** to be used with Question 2.

