



Rewarding Learning

ADVANCED
General Certificate of Education
2012

Centre Number

71	
----	--

Candidate Number

--

Physics

Assessment Unit A2 3
Practical Techniques
(Internal Assessment)
Session 1

[AY231]



TUESDAY 8 MAY, MORNING

TIME

1 hour 30 minutes.

INSTRUCTIONS TO CANDIDATES

Write your Centre Number and Candidate Number in the spaces provided at the top of this page.

Turn to page 2 for further Instructions and Information.

Question Number	Marks		
	Teacher Mark	Examiner Check	Remark
1			
2			
3			
Total Marks			



7457

INSTRUCTIONS TO CANDIDATES

Answer **all** questions in this paper. Rough work and calculations must also be done in this paper. Except where instructed, do not describe the apparatus or experimental procedures. The Supervisor will tell you the order in which you are to answer the questions. Not more than 30 minutes are to be spent in answering each question. You may be told to start with the experimental tests in Section A, or with the single question in Section B.

Section A consists of two experimental tests. A 28-minute period is allocated for you to use the apparatus. Two minutes is allocated to the supervisor to prepare the station for the next candidate. At the end of the 30-minute period you will be instructed to move to the area set aside for your next question. Section B consists of one question in which you will be tested on aspects of planning and design.

INFORMATION FOR CANDIDATES

The total mark for this paper is 60.

All questions carry 20 marks each.

Figures in brackets printed down the right-hand side of pages indicate the marks awarded to each part question.

You may use an electronic calculator.

BLANK PAGE

(Questions start overleaf)

Section A

- 1 In this experiment you will investigate the oscillation of five wooden laths about a pivot close to one end of each lath.

The aims of the experiment are:

- To obtain the period of oscillation for each lath
- To use the results to plot a linear graph
- To use the graph to determine the value of a constant n

Apparatus

The apparatus, with the longest lath in place, has been set up as shown in **Fig. 1.1**.

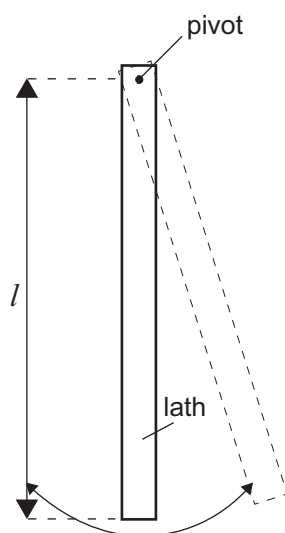

Fig. 1.1

- (a) Measure and record the length, l , the distance between the pivot and the end of the lath in **Table 1.1**. Set the lath swinging with small amplitude oscillations. Take and record sufficient readings to obtain an accurate value for T , the period of oscillation. Record your readings in **Table 1.1**.

Repeat the procedure for the other four laths.

Teacher Mark	Examiner Check	Remark

Table 1.1

l/cm		T/s	T^2/s^2

[5]

(b) The relationship between T and l is given by **Equation 1.1**

$$T = 2\pi\sqrt{\frac{nl}{g}} \quad \text{Equation 1.1}$$

where g is the acceleration of free fall, of value 981 cm s^{-2} and n is a constant.

You are required to plot a straight line graph to enable you to find the value of the constant n .

(i) Using **Equation 1.1**, show that plotting a graph of T^2 on the vertical axis against l on the horizontal axis gives a linear graph.

[2]

(ii) How would the value of n be found from the graph suggested in (i)?

_____ [2]

(iii) A blank column in **Table 1.1** has been provided for the values of T^2 . Calculate and record the values in the table. [1]

Teacher Mark	Examiner Check	Remark

(c) Plot the graph of T^2 against l on the grid of **Fig. 1.2**. Choose suitable scales, plot the five points and draw the best fit line. [4]

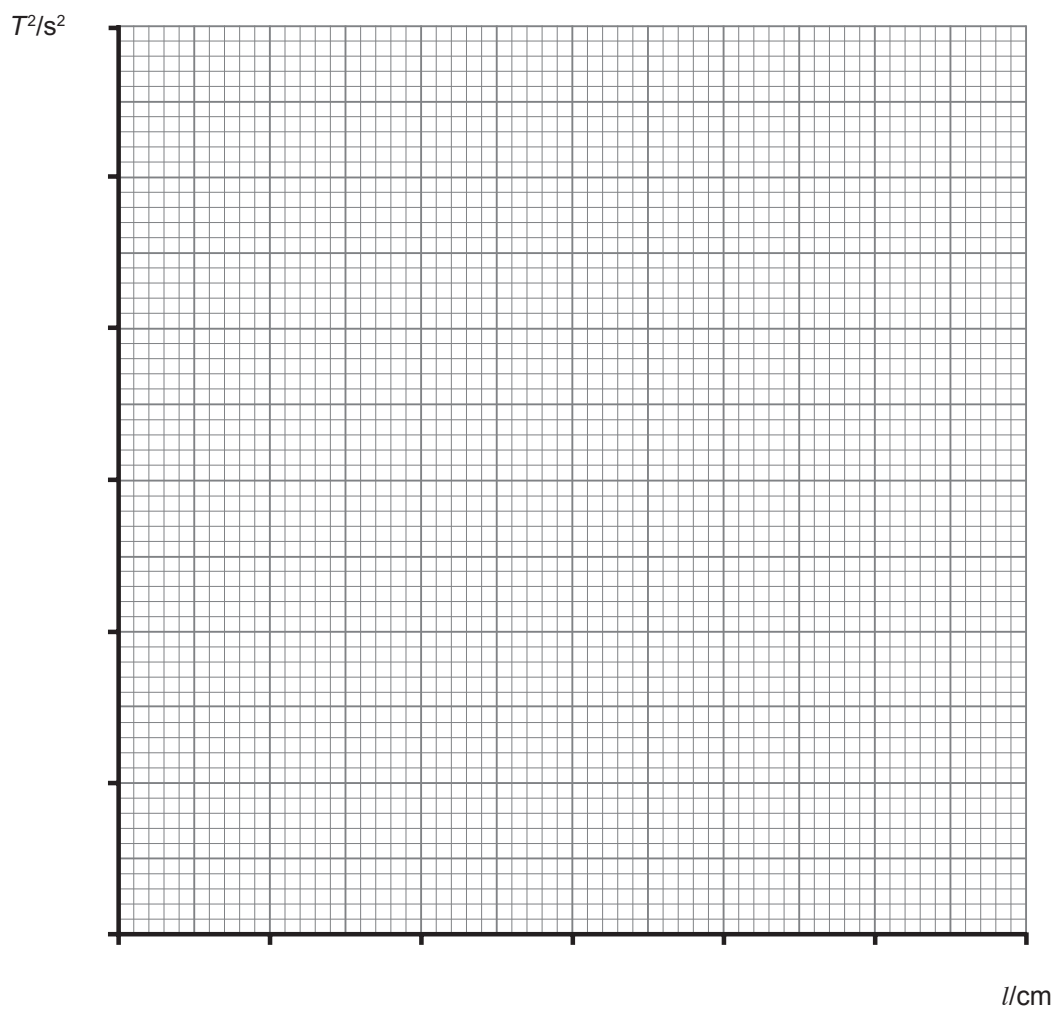

Fig. 1.2

Teacher Mark	Examiner Check	Remark

(d) Use your graph to find a value for the constant n .

$$n = \underline{\hspace{4cm}}$$

[4]

(e) Show that the constant n has no unit.

[2]

Teacher Mark	Examiner Check	Remark

2 Introduction

In this experiment you will find the resistance of an unknown resistor P, which is joined in series with a variable resistor Q. Different currents will be passed through the two resistors. The potential difference across each resistor and the current will be measured.

The aims of the experiment are:

- To measure current and voltages
- To plot a straight line graph to obtain values of two constants A and B
- To determine the value of the unknown resistor P .

Apparatus

You are supplied with a box which contains the two resistors arranged as shown in **Fig. 2.1**. Variable resistor Q is connected between the terminals X and Y and resistor P between terminals Y and Z.

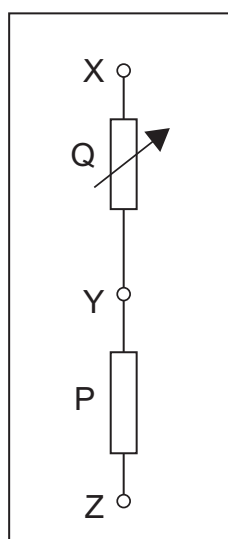

Fig. 2.1

Teacher Mark	Examiner Check	Remark

The circuit shown in **Fig. 2.2** has been connected for you.

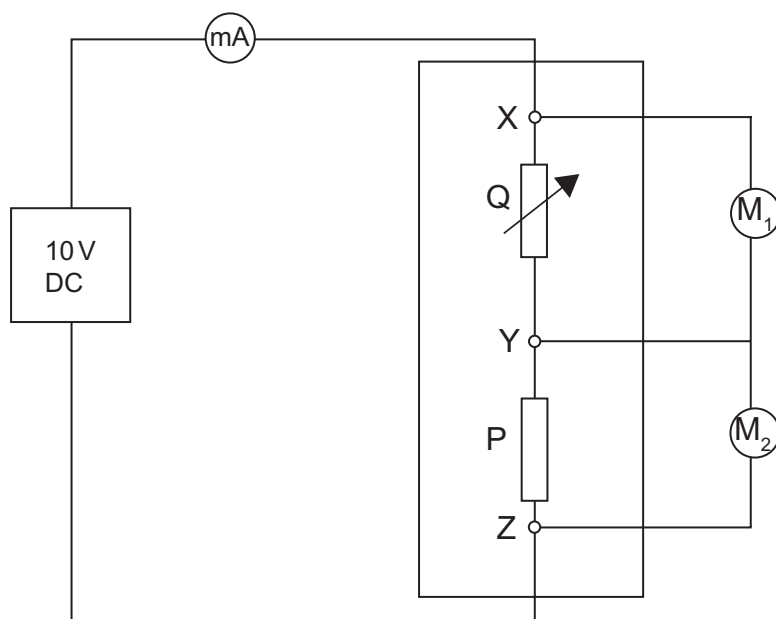

Fig. 2.2

- (a) Voltmeter M_1 measures the potential difference V_1 across resistor Q and voltmeter M_2 measures the potential difference V_2 across resistor P. The milliammeter measures the current I in the circuit.

Switch on the power supply and rotate the knob of the variable resistor fully clockwise. The voltmeters M_1 and M_2 should read 0V and approximately 10V respectively.

- (i) With the knob of the variable resistor still fully clockwise, read the value indicated by voltmeter M_2 .

Record this voltage as V_o .

$$V_o = \text{_____ V}$$

- (ii) Rotate the knob of the variable resistor slightly anti-clockwise and record the values of I , V_1 and V_2 in **Table 2.1**.

Teacher Mark	Examiner Check	Remark

Table 2.1

I/mA	V_1/V	V_2/V	R_Q/Ω	$1/V_2/\text{V}^{-1}$

[3]

Repeat this procedure four more times until the knob of the variable resistor is fully anti-clockwise.

(b) (i) For each of the readings of I and V_1 calculate the corresponding values of R_Q . [2]

(ii) Take the uncertainty in the ammeter and voltmeter to be $\pm 0.01 \text{ mA}$ and $\pm 0.01 \text{ V}$ respectively. Calculate the absolute uncertainty in the R_Q value you have calculated in the bottom row of **Table 2.1**.

Absolute uncertainty = \pm _____ Ω [3]

Teacher Mark	Examiner Check	Remark

- (c) The potential difference V_2 is related to the resistance R_Q by **Equation 2.1**

$$R_Q = \frac{A}{V_2} - B \quad \text{Equation 2.1}$$

where A and B are constants.

A graph of R_Q against $1/V_2$ will give a straight line of slope A and intercept B.

- (i) Calculate values for $1/V_2$ and record them in **Table 2.1**. [1]

- (ii) Plot the graph R_Q against $1/V_2$ on the grid of **Fig. 2.3**. Choose suitable scales, plot the five points and draw the best fit line. [4]

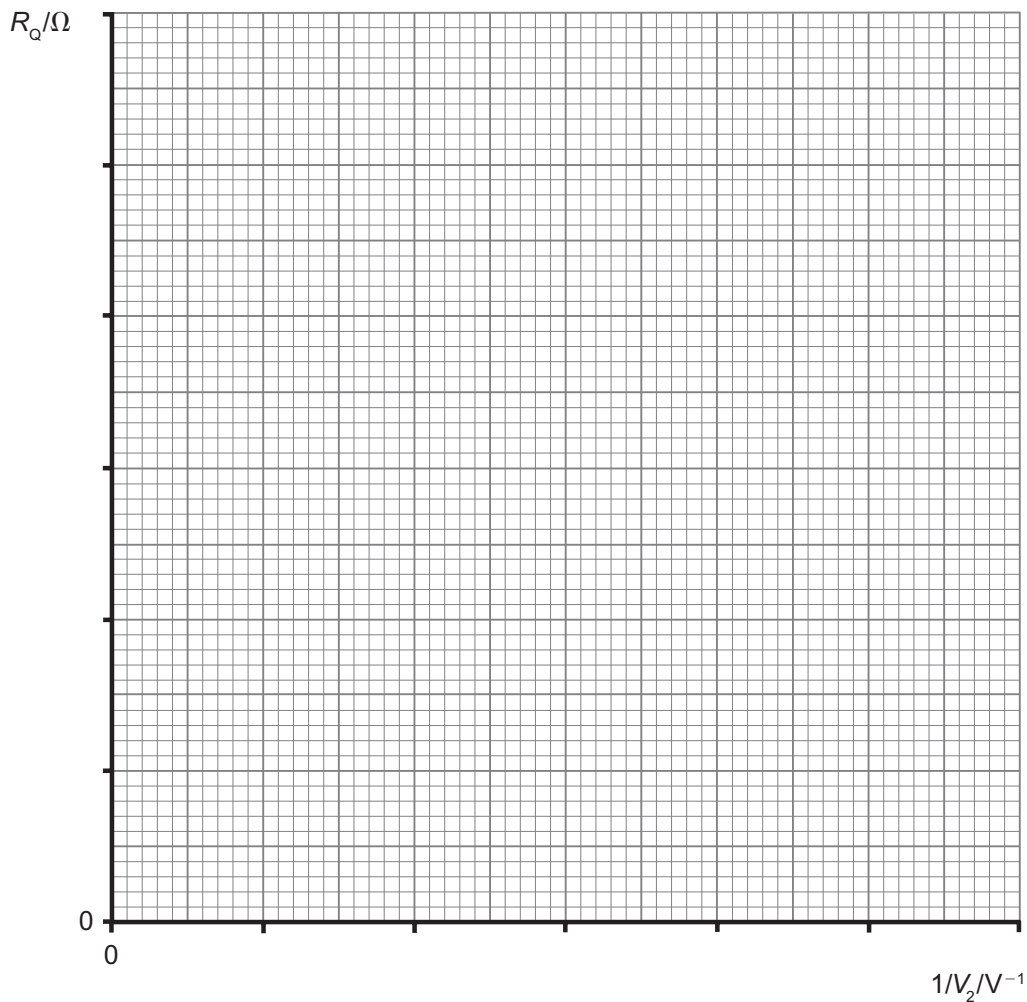

Fig. 2.3

Teacher Mark	Examiner Check	Remark

(d) (i) Use the graph you have plotted to find the value of A .

$A = \text{_____ } \text{V}\Omega$ [2]

(ii) Why can the value of B not be obtained **directly** from Fig. 2.3?

_____ [1]

(iii) The value of B can still be obtained by calculation. Calculate the value of B .

$B = \text{_____ } \Omega$ [3]

(e) The resistance R_p of resistor P is equal to A/V_o . Calculate the value of R_p and record it below. (Remember, V_o was recorded in (a)(i).)

$R_p = \text{_____ } \Omega$ [1]

Teacher Mark	Examiner Check	Remark

Section B

3 In this question you will plan an experiment to determine the sound absorption coefficient of a test material.

The sound absorption coefficient a describes how efficient a material is at absorbing sound. See **Fig. 3.1**.

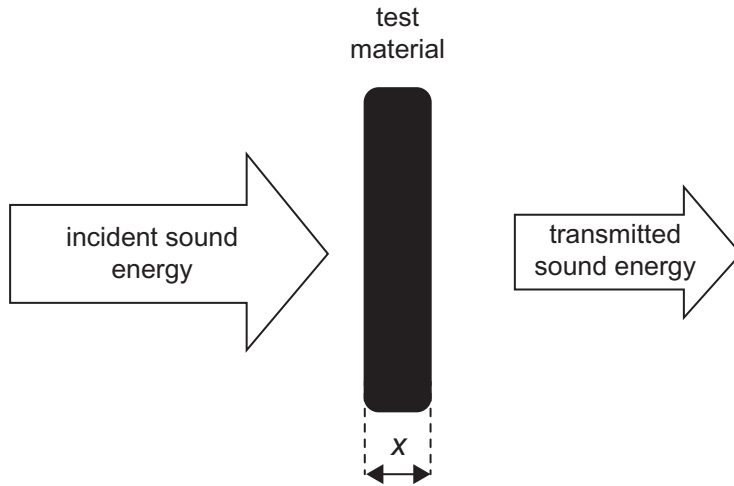

Fig. 3.1

The amplitude of the sound wave is proportional to the energy of the sound wave. Theory suggests that the amplitude of the transmitted sound wave varies exponentially with test material thickness x according to **Equation 3.1**.

$$A_x = A_o e^{-ax} \quad \text{Equation 3.1}$$

A_x is the amplitude after passing through distance x of the test material, A_o is the incident amplitude and a is the sound absorption coefficient.

(a) (i) You are provided with a loudspeaker, a microphone, a signal generator, three sheets of test material of thicknesses 4 mm, 7 mm and 15 mm and a cathode ray oscilloscope (CRO). Describe how this apparatus would be arranged to allow data to be collected that would allow the sound absorption coefficient a to be determined.

[4]

Teacher Mark	Examiner Check	Remark

- (ii) The height of the trace on the CRO varies with the amplitude of the transmitted sound waves. Name the **controls** on the cathode ray oscilloscope that have to be adjusted to obtain a single vertical line trace that almost fills the screen.

[2]

- (iii) When using the CRO a more appropriate form of **Equation 3.1** is given by **Equation 3.2**.

$$V_x = V_o e^{-ax} \quad \text{Equation 3.2}$$

Outline the steps required to determine the voltage, V_x , represented by the vertical line trace.

[3]

- (b) Describe the procedure that would be followed to obtain sufficient readings of V_x and x to plot a meaningful graph. Remember the sheets of test material have thicknesses of 4 mm, 7 mm and 15 mm.

[3]

Teacher Mark	Examiner Check	Remark

Permission to reproduce all copyright material has been applied for.
In some cases, efforts to contact copyright holders may have been unsuccessful and CCEA
will be happy to rectify any omissions of acknowledgement in future if notified.



Rewarding Learning

ADVANCED
General Certificate of Education
2012

Physics

Assessment Unit A2 3

assessing

Practical Techniques
Sessions 1 and 2

[AY231] [AY232]

TUESDAY 8 MAY AND THURSDAY 10 MAY



AY231 AY232

APPARATUS AND MATERIALS LIST

A2 PHYSICS UNIT 3 (A2 3) APPARATUS AND MATERIALS REQUIRED FOR PRACTICAL ASSESSMENTS

CONFIDENTIAL

Information about the apparatus and materials required for the A2 Practical Assessments **must not** be communicated to candidates sitting the examination.

This document gives preliminary information on the apparatus and materials required for the A2 Practical Assessments. The Practical Assessments will be marked by teachers as part of the internal assessment requirements for the GCE Physics Specification.

Teachers will be given detailed instructions for setting up the experiments in the *Confidential Instructions for Physics (A2) Practical Tests*, to which they will have confidential access from March 2012.

Teachers will have confidential access to a copy of the experimental tests two working days (48 hours) before the start of the assessment.

The A2 3 Practical Techniques Assessment is a test of practical skills consisting of Section A and Section B. Section A comprises 2 experimental tests (40 marks) and Section B consists of one question which tests aspects of planning and design (20 marks). The duration of the assessment is 1 hour 30 minutes. Some of this time will be set aside for supervisors to re-set apparatus for the next candidates. In each of the experimental tests (Q1 and Q2), candidates must stop using the apparatus after 28 minutes. At the end of each 28 minute period, a changeover time of 2 minutes will be set aside for the supervisor to re-set the apparatus for the next candidates. During the changeover periods, candidates may write-up anything they have not completed, however they will not have access to the apparatus. Candidates will move on to the next question after 30 minutes. The time allocation for **question 3** (planning and design) is 30 minutes. As the time allocation for each question is effectively the same, the supervisor can decide in which order the candidates should attempt the questions.

The apparatus in the following list will allow for **one experiment** to be set up for each of the practical tests which make up **questions 1 and 2**. In other words, each set of apparatus (as listed on page 4) will accommodate three candidates.

The apparatus can be used for alternative sessions according to the following schedule:

Tuesday 8 May 2012 Physics A2 3A (AY231)

(Main Session) **9.15 a.m. – 10.45 a.m.**
(First Alternative) **11.00 a.m. – 12.30 p.m.**
(Second Alternative) **1.15 p.m. – 2.45 p.m.**
(Third Alternative) **3.00 p.m. – 4.30 p.m.**

Thursday 10 May 2012 Physics A2 3B (AY232)

(Main Session) **9.15 a.m. – 10.45 a.m.**
(First Alternative) **11.00 a.m. – 12.30 p.m.**
(Second Alternative) **1.15 p.m. – 2.45 p.m.**
(Third Alternative) **3.00 p.m. – 4.30 p.m.**

One set of apparatus for A2 3A (AY231) will therefore be sufficient for twelve candidates on **8 May** if the Main Session and all three alternatives are used. Similarly, one set of apparatus for A2 3B (AY232) will be sufficient for twelve candidates on **10 May** if the Main Session and all three alternatives are used. A laboratory may contain one, two, three or more sets of apparatus. This means that three, six, nine or more candidates can be accommodated in the same session. **When alternative sessions are used care must be taken to segregate candidates who have taken the examination from those who have still to sit the examination.**

IMPORTANT NOTICE

Centres are urged to order items needed for the Physics Practical Tests from the suppliers as soon as possible.

Question 1

Ref	Component	Session 1	Session 2
1.1	Metre rule (wooden) (to be cut)	4	2
1.2	Optical pin	1	1
1.3	Cork	1	1
1.4	Retort stand, clamp and boss head	1	1
1.5	Stopclock to 0.01s	1	1

Question 2

Ref	Component	Session 1	Session 2
2.1	Box, wooden or plastic about 100 mm × 100 mm × 30 mm	1	1
2.2	Panel sockets (4 mm)		
	black	1	1
	red	2	2
2.3	Connecting leads about 300 mm long fitted with 4 mm plugs at each end	7	7
2.4	Potentiometer 4.7 k Ω , 0.4 W, e.g. Rapid 65–0510, with knob, e.g. Rapid 32–0175	1	1
2.5	Resistors (0.5 W ~ 1% tolerance)		
	1.2 k Ω , e.g. Rapid 62–0558	1	X
	1.5 k Ω , e.g. Rapid 62–0560	X	1
2.6	Smoothed d.c. power supply 10 mA at 10 V	1	1
2.7	Digital voltmeter, 0–10 V d.c. to 0.01 V	2	2
2.8	Digital milliammeter, 0–10 mA d.c. to 0.01 mA	1	1
2.9	Connecting wire and solder		
2.10	Self-adhesive labels		



Rewarding Learning

ADVANCED
General Certificate of Education
2012

Physics

Assessment Unit A2 3

assessing

Practical Techniques (Internal Assessment)

[AY231] [AY232]

TUESDAY 8 MAY AND THURSDAY 10 MAY

CONFIDENTIAL INSTRUCTIONS TO TEACHERS

CONFIDENTIAL INSTRUCTIONS FOR PHYSICS A2 PRACTICAL TEST

Confidentiality

To maintain the integrity of the Test, no question papers or any material pertaining to the Test should be publicly released until after the final session.

General

The Practical Test will contain three compulsory questions, of which two are 30-minute experimental tests and the third is a 30-minute question testing Planning and Design. The total time allowed is 1 hour 30 minutes. The order in which candidates are to take the questions is to be decided by the Supervisor. Candidates will have access to the apparatus in the experimental tests for 28 minutes each, the final two minutes being reserved for adjustment of the apparatus by the Supervisor. The question paper includes spaces for answers; candidates will write their answers in the Question/Answer booklet.

Question 1

Ref	Component	Session 1	Session 2
1.1	Metre rule (wooden) (to be cut)	4	2
1.2	Optical pin	1	1
1.3	Cork	1	1
1.4	Retort stand, clamp and boss head	1	1
1.5	Stopclock to 0.01s	1	1

SESSION 1

Preparation

Take two of the metre rules and cut the first one to give two laths, one 80 cm long and the other 20 cm long. Cut the second to give two laths, one 60 cm long and the other 40 cm long. The final lath is a 100 cm metre rule.

Drill a hole through each of the laths on the centre line 5 cm from one end of each of the 5 laths. The diameter of the hole must be such that the **HEAD** of the optical pin just passes easily through the hole.

Insert the optical pin into the cork, approximately along the axis of the cork, so that the head projects about 10 mm from the cork.

Mount the cork in the retort stand using the boss head and clamp so the the pin is horizontal and the head is slightly beyond the bench. Check that, when the hole in each lath is slipped over the pinhead, the lath will oscillate freely about the pin as a pivot, without striking the bench.

Ensure that the retort stand is sufficiently secure, so that on changing the lath on the pin, it does not move.

Before the Examination

Place the 100 cm lath on the pin. Place the four shorter laths, metre rule and stopclock on the bench, adjacent to the retort stand.

Action at Changeover

Zero the stopclock.

Place the 100 cm lath on the pin.

Check that the pin is horizontal.

Place the four shorter laths, metre rule and stopclock on the bench, adjacent to the retort stand.

Information required by Examiners

None

SESSION 2

Preparation

Drill holes along the centre line of the metre rule at the marks 20 cm, 25 cm, 30 cm, 35 cm and 40 cm. The diameter of the hole must be such that the **HEAD** of the optical pin just passes easily through the hole.

Insert the optical pin into the cork, approximately along the axis of the cork, so that the head projects about 10 mm from the cork.

Mount the cork in the retort stand using the boss head and clamp so that the pin is horizontal and the head is slightly beyond the bench. Check that, when each hole in the metre rule is slipped over the pinhead, the metre rule will oscillate freely about the pin as a pivot, without striking the bench.

Ensure that the retort stand is sufficiently secure, so that when removing and replacing the metre rule on the pin it does not move.

Before the Examination

Hang the metre rule on the pin at the 20 cm mark.
Place the other metre rule and stopclock on the bench, close to the stand with the pivot.

Action at Changeover

Zero the stopclock.
Hang the metre rule on the pin at the 20 cm mark.
Check that the pin is horizontal.
Place the other metre rule and stopclock on the bench, close to the stand with the pivot.

Information required by Examiners

None.

Question 2

Ref	Component	Session 1	Session 2
2.1	Box, wooden or plastic about 100 mm × 100 mm × 30 mm	1	1
2.2	Panel sockets		
	black	1	1
	red	2	2
2.3	Connecting leads about 300 mm long fitted with 4 mm plugs at each end	7	7
2.4	Potentiometer, 4.7 k Ω , 0.4 W with knob	1	1
2.5	Resistors 0.5 W 1% tolerance		
	1.2 k Ω	1	X
	1.5 k Ω	X	1
2.6	Smoothed d.c. power supply 10 mA at 10 V	1	1
2.7	Digital voltmeter, 0–10 V d.c. to 0.01 V	2	2
2.8	Milliammeter, 0–10 mA to 0.01 mA	1	1
2.9	Connecting wire and solder		
2.10	Self-adhesive labels		

SESSION 1

Preparation

Potential Divider Box

Drill four holes of appropriate size in the lid of the box as shown in **Fig. 2.1**.

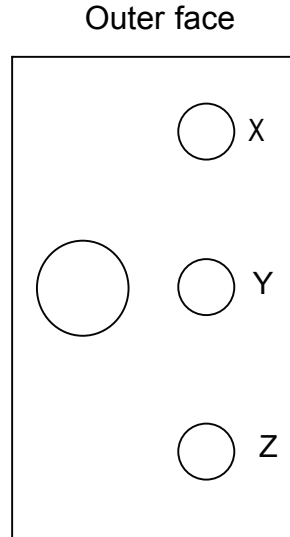

Fig. 2.1

Label the outer face of the box as shown in **Fig. 2.1**. Fit red 4 mm sockets to the holes at X and Y and a black 4 mm socket to the hole at Z. Fit the potentiometer so that its spindle protrudes on the outside of the lid. Viewing the outer face of the box, turn the potentiometer spindle fully clockwise. With the spindle in this position, select the two terminals on the potentiometer between which the resistance is approximately zero (the centre terminal and the appropriate outer terminal). These terminals are used in wiring the circuit in **Fig. 2.2**. Make the soldered connections as shown so that the potentiometer acts as a variable resistor.

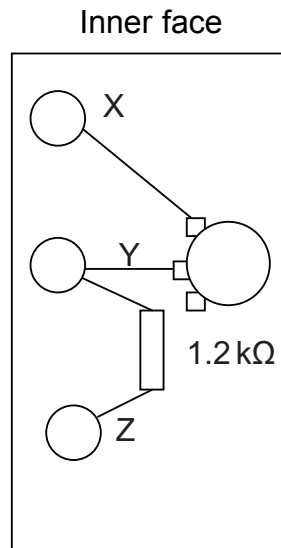

Fig. 2.2

Connect X to the negative terminal of the milliammeter and connect Z to the negative terminal of the power supply as shown in **Fig. 2.3**. Set the smoothed d.c. supply to provide 10V, but no more. Tape the output control in this position. Fit the knob to the potentiometer spindle and label the voltmeters M_1 and M_2 . Connect the voltmeters as shown in **Fig. 2.3**.

Fig. 2.3 is the pre-connected circuit provided for the candidate.

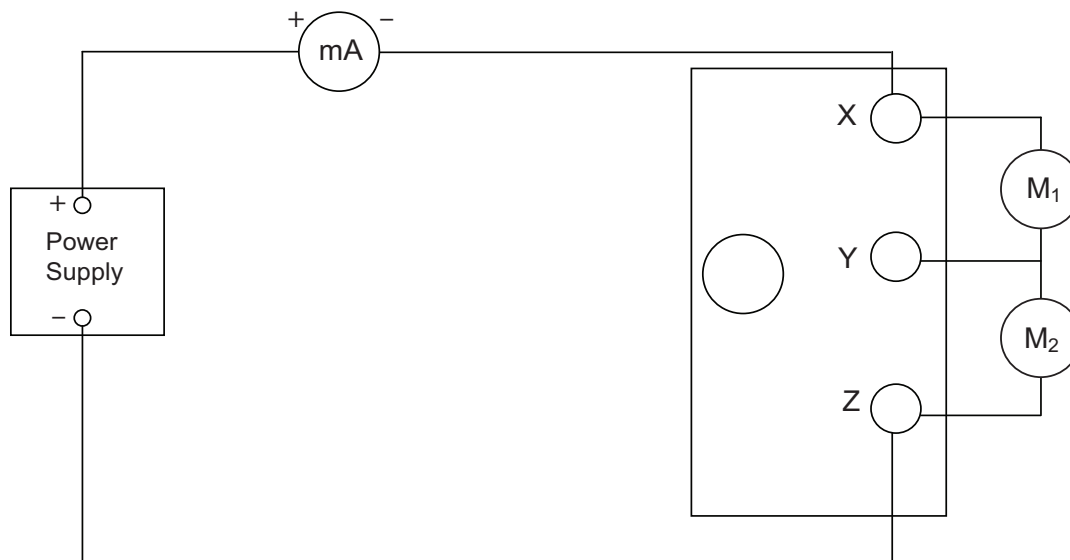

Fig. 2.3

Testing

Having set up the circuit shown in **Fig. 2.3** rotate the potentiometer knob fully clockwise. Check that the output voltage between X and Y is approximately zero, and the voltage between Y and Z is about 10V. Rotate the knob anticlockwise: the voltage between X and Y should rise to about 8V (7V in Session 2) eventually, and that between Y and Z should fall to about 2V (3V in Session 2). If these readings are not obtained, check the connections to the terminals and in particular the connections to the potentiometer. Correct the connections to obtain the stated values.

Close and seal the box.

Before the Examination

Provide the circuit as shown in **Fig. 2.3**. Leave it with the power supply switched off.

Action during Examination

None.

Action at Changeover

Switch off power supply.

Ensure that the circuit is connected as in **Fig. 2.3**.

SESSION 2

Same as Session 1 except that the $1.2\text{ k}\Omega$ is replaced with the $1.5\text{ k}\Omega$ resistor.

Question 3 – Session 1 and Session 2

Apart from the provision of a suitable working area, no apparatus is required for the planning and design question

Information required by examiners

None.

