

Surname		Other Names	
Centre Number		Candidate Number	
Candidate Signature			

Leave blank

General Certificate of Education
 January 2004
 Advanced Subsidiary Examination



PHYSICS (SPECIFICATION B)
Unit 3 Practical

PHB3

Tuesday 20 January 2004 Morning Session

<p>In addition to this paper you will require:</p> <ul style="list-style-type: none"> • a calculator; • A4 graph paper; • a ruler.
--

For Examiner's Use			
Number	Mark	Number	Mark
1			
2			
3			
Total (Column 1)	→		
Total (Column 2)	→		
TOTAL			
Examiner's Initials			

Time allowed: 2 hours

Instructions

- Use a blue or black ball-point pen.
- Fill in the boxes at the top of this page.
- Answer **all** questions in the spaces provided. A separate sheet of graph paper is required for Question 3.
- All working must be shown. Do all rough work in this book. Cross through any work you do not want marked.

Information

- The maximum mark for this paper is 78.
- Mark allocations are shown in brackets.
- You are expected to use a calculator where appropriate.
- You will be assessed on your ability to use an appropriate form and style of writing, to organise relevant information clearly and coherently, and to use specialist vocabulary where appropriate.
- The degree of legibility of your handwriting and the level of accuracy of your spelling, punctuation and grammar will also be taken into account.

Advice

- You are allowed 30 minutes for each of Questions 1 and 2, and one hour for Question 3.
- Before commencing the first part of any question, read the question through completely.

Answer **all** questions in the spaces provided.

30 minutes are allowed for this question.

Total for this question: 20 marks

- 1 You are going to investigate the rate at which kitchen paper absorbs water.

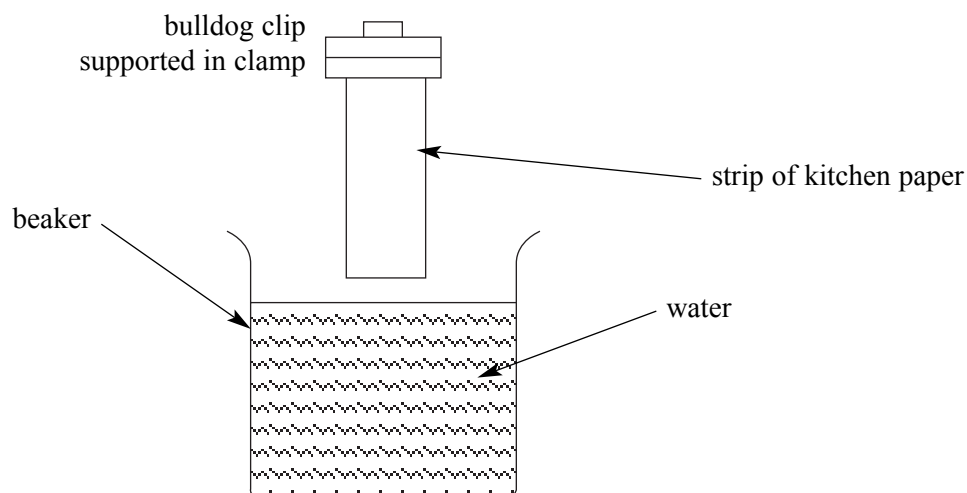

Figure 1

- (a) Set up the arrangement shown in **Figure 1**. Mount a strip of the paper so that its lower edge is initially about 5 mm above the water surface and parallel to it.

- (i) Add water to the beaker until the water touches the bottom edge of the paper strip.

Observe what happens for about 30 s and record the maximum height, H , above the bottom edge of the strip that the water reaches.

$H = \dots\dots\dots$ mm (1 mark)

- (ii) Sketch, on the axes below, a graph to show how you think the height reached by the water varies with time.

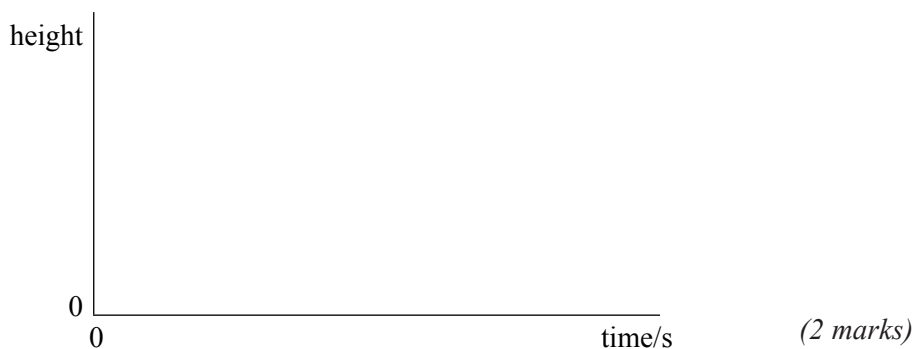

- (b) The purpose of kitchen paper is to soak up as much liquid as possible. State a measurement that would provide a better test than the height to which the water rises and describe briefly how you would make the measurement.

.....

.....

.....

.....

(3 marks)

- (c) (i) Calculate $h = 0.75 H$, where H is the measurement you made in part (a)(i).

$$h = \dots\dots\dots$$

On a new dry strip, draw a line a distance, h , above the bottom edge of the strip.

Repeat the procedure in part (a) starting timing at the instant the water touches the bottom edge of the paper.

Measure and record the time, t , for the water to reach the line you have drawn.

(2 marks)

- (ii) Calculate R , the average rate of change of height. Give your answer in mm s^{-1} .

(1 mark)

- (iii) State clearly the absolute uncertainties in h and t .

Absolute uncertainty in h

Absolute uncertainty in t

(2 marks)

- (iv) Calculate the percentage uncertainty in R .

Percentage uncertainty in R

(2 marks)

QUESTION 1 CONTINUES ON THE NEXT PAGE

Turn over ►

30 minutes are allowed for this question.

Total for this question: 20 marks

- 2 You are going to investigate how the depth to which a pencil penetrates water varies with the height from which it is dropped.

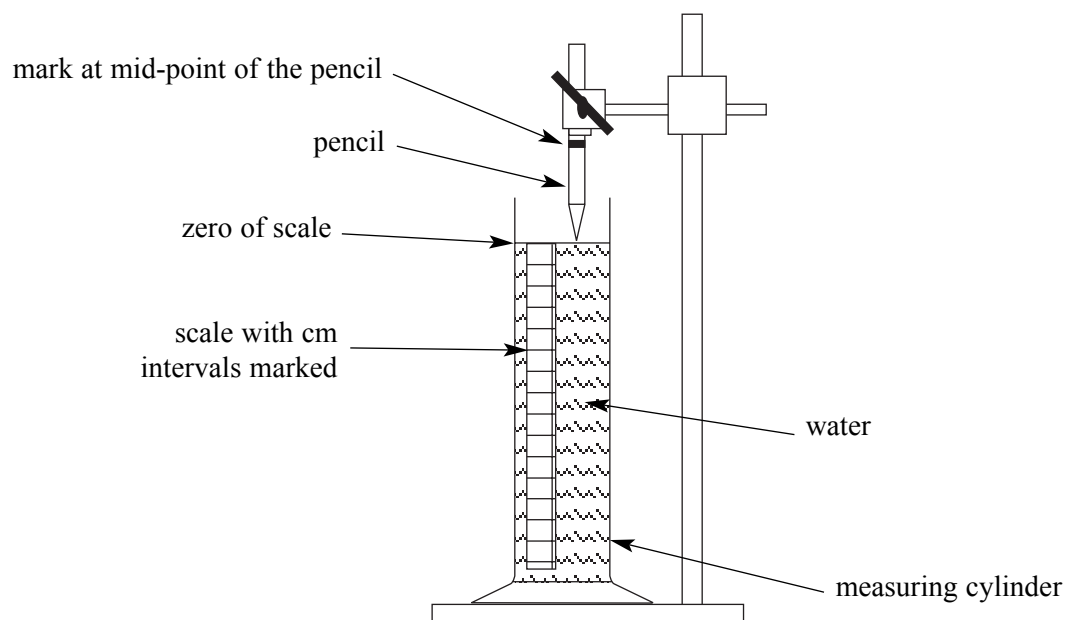

Figure 2

- (a) (i) Support the pencil in the retort stand clamp so that its sharpened end is just touching the surface of the water, as shown in **Figure 2**. Release the pencil from the clamp and determine the depth to which its lower end penetrates the water.

(2 marks)

- (ii) Repeat part (a)(i) with the flat end of the pencil just touching the surface of the water.

(1 mark)

QUESTION 2 CONTINUES ON THE NEXT PAGE

Turn over ►

- (iii) State any **one** difficulty you had when making the measurements in parts (a)(i) and (a)(ii) and state how you would modify the experiment to overcome the problem.

.....

.....

.....

.....

.....

(2 marks)

- (b) It is suggested that when the sharpened end of the pencil is at the bottom, the depth of penetration, D , of the mid-point of the pencil is proportional to the initial height, H , of the mid-point of the pencil above the water surface. The mid-point of the pencil is marked on it.

- (i) Make measurements using the values of H given in the table. Record your measurements in the table. You should rule in any additional columns that you need.

H/mm	
50	
70	
90	

(3 marks)

- (ii) Use your data to perform calculations to test whether D is proportional to H .

State below what you calculated, the results of your calculations and what you conclude from your calculations.

(4 marks)

One hour is allowed for this question.

Total for this question: 38 marks

- 3 You are going to measure the resistance, X , of a wire. **Figure 3** shows the circuit arrangement.

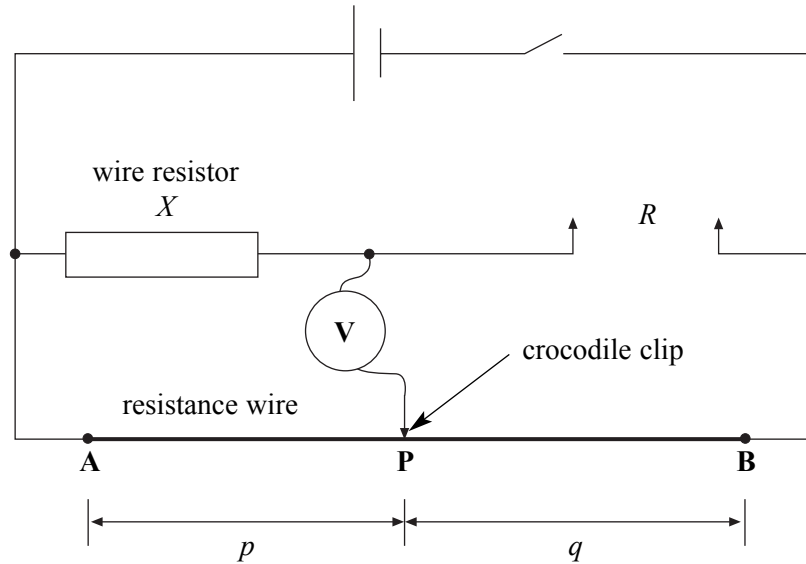

Figure 3

- (a) (i) Use the $3.9\ \Omega$ resistor for R . Touch the crocodile clip on to the wire AB and adjust its position P until the voltmeter records $0\ \text{V}$.

Note you should not clip the crocodile clip on to the wire as this will cause kinks which may affect your data.

Measure and record the lengths p and q , shown in **Figure 3**. Give the values in m.

(2 marks)

- (ii) State the absolute uncertainty in the values of p and q . Explain how you decided on the value of this uncertainty.

.....

.....

.....

.....

(2 marks)

- (iii) Suggest **two** ways in which the apparatus could be modified to reduce this uncertainty.

.....

.....

.....

.....

(2 marks)

- (iv) When the voltmeter reads 0 V, the potential difference across the wire **AP** is V . State which other component in the circuit has a potential difference V across it.

.....

(1 mark)

- (b) (i) The resistance X , in Ω , is given by

$$X = \frac{p}{q} R$$

Calculate a value for X .

(3 marks)

- (ii) State and explain **one** reason why the method in part (a) would be unsuitable for measuring the value of a resistance of about 0.1Ω

.....

.....

.....

.....

(2 marks)

QUESTION 3 CONTINUES ON THE NEXT PAGE

Turn over ►

- (c) You are now going to obtain the corresponding values of p using other resistance values. This will enable you to find the value of X by a graphical method.
- (i) Draw below a table in which to record all your values for R and p . Include in your table a column in which to record the corresponding values for $\frac{1}{p}$.
- (3 marks)*
- (ii) Repeat the procedure in part (a)(i) for each of the resistors provided and record your data in the table. When you have finished you should have 5 sets of data including the measurements made in part (a).

(9 marks)

- (d) (i) Plot a graph of R (y -axis) against $\frac{1}{p}$ (x -axis).

Draw the best straight line through your plotted points.

(7 marks)

- (ii) Determine the gradient of your graph.

(3 marks)

- (e) The equation for your line is

$$R = \frac{kX}{p} - X$$

where $k = 0.75 \text{ m}$.

The equation for a straight line graph is $y = mx + c$.

- (i) Using your gradient determine a second value for X .

(2 marks)

- (ii) State and explain whether the value from part (e)(i) or from part (b)(i) is more reliable.

.....

.....

.....

.....

(2 marks)

END OF QUESTIONS