

Centre Number						Candidate Number				
Surname										
Other Names										
Candidate Signature										

For Examiner's Use	
Examiner's Initials	
Question	Mark
1	
2	
3	
4	
5	
6	
7	
TOTAL	



General Certificate of Education  
Advanced Subsidiary Examination  
June 2009

# Physics A

# PHYA1

## Unit 1 Particles, Quantum Phenomena and Electricity

Thursday 21 May 2009 1.30 pm to 2.45 pm

**For this paper you must have:**

- a pencil and a ruler
- a calculator
- a Data and Formulae book.

**Time allowed**

- 1 hour 15 minutes

**Instructions**

- Use black ink or black ball-point pen.
- Fill in the boxes at the top of this page.
- Answer **all** questions.
- You must answer the questions in the spaces provided. Answers written in margins or on blank pages will not be marked.
- Do all rough work in this book. Cross through any work you do not want to be marked.

**Information**

- The marks for questions are shown in brackets.
- The maximum mark for this paper is 70.
- You are expected to use a calculator where appropriate.
- A *Data and Formulae Book* is provided as a loose insert.
- You will be marked on your ability to:
  - use good English
  - organise information clearly
  - use specialist vocabulary where appropriate.



J U N 0 9 P H Y A 1 0 1

Answer **all** questions in the spaces provided.

- 1 (a) Explain what is meant by an isotope.

.....

.....

.....

.....

(2 marks)

- 1 (b) The incomplete table shows information for two isotopes of uranium.

	number of protons	number of neutrons	specific charge of nucleus/.....
first isotope	92	143	
second isotope			$3.7 \times 10^7$

- 1 (b) (i) Write the unit for the specific charge in the heading of the last column of the table.

(1 mark)

- 1 (b) (ii) In the above table write down the number of protons in the second isotope in the table.

(1 mark)



1 (b) (iii) Calculate the specific charge of the first isotope and write this in the table.

.....  
.....  
.....  
.....

(3 marks)

1 (b) (iv) Calculate the number of neutrons in the second isotope and put this number in the table

.....  
.....  
.....  
.....  
.....

(3 marks)

<b>10</b>

**Turn over for the next question**

**Turn over ▶**



- 2 Electrons with a range of kinetic energies strike atoms of a particular element which are in their *ground state*. As a result of these collisions photons of various frequencies are emitted by some of the atoms.
- 2 (a) Explain what is meant by the ground state of an atom and describe the process that is taking place in the atoms emitting photons.

The quality of your written communication will be assessed in this question.

.....

.....

.....

.....

.....

.....

.....

.....

.....

.....

.....

.....

.....

.....

.....

*(6 marks)*



- 2 (b) The table below shows how the kinetic energies of electrons with different incident energies may change after collisions with atoms.

	kinetic energy of electron before collision/eV	kinetic energy of electron after collision/eV
First electron	5.5	5.5
Second electron	9.0	1.0

- 2 (b) (i) Explain why one of the electrons loses energy while the other does not.

.....  
 .....  
 .....  
 .....

(2 marks)

- 2 (b) (ii) Convert the energy of 9.0 eV into joules

.....  
 .....  
 .....  
 .....

(2 marks)

- 2 (b) (iii) Calculate the **maximum** frequency of the photon emitted when the 9.0 eV electron collides with an atom.

.....  
 .....  
 .....  
 .....  
 .....  
 .....

answer.....Hz  
 (3 marks)



3 (a) The  $\Sigma^+$  particle is a baryon with strangeness  $-1$ .

3 (a) (i) How many quarks does the  $\Sigma^+$  particle contain?

.....  
.....

answer.....  
(1 mark)

3 (a) (ii) How many of the quarks are strange?

.....  
.....

answer.....  
(1 mark)

3 (b) The  $\Sigma^+$  decays in the following reaction

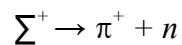

3 (b) (i) State **two** quantities that are conserved in this reaction.

.....  
.....

(2 marks)

3 (b) (ii) State a quantity that is not conserved in this reaction.

.....

(1 mark)

3 (b) (iii) What interaction is responsible for this reaction?

.....

(1 mark)

3 (b) (iv) Into what particle will the neutron formed in this reaction eventually decay?

.....

(1 mark)

7
---



4 When monochromatic light is shone on a clean metal surface, electrons are emitted from the surface due to the photoelectric effect.

4 (a) State and explain the effect on the emitted electrons of

4 (a) (i) increasing the frequency of the light,

.....  
.....  
.....  
.....

*(2 marks)*

4 (a) (ii) increasing the intensity of the light.

.....  
.....  
.....  
.....

*(2 marks)*

4 (b) The wave model was once an accepted explanation for the nature of light. It was rejected when validated evidence was used to support a particle model of the nature of light. Explain what is meant by **validated evidence**.

.....  
.....  
.....  
.....

*(2 marks)*

**Question 4 continues on the next page**

**Turn over ▶**



4 (c) The threshold frequency of lithium is  $5.5 \times 10^{14}$  Hz.

4 (c) (i) Calculate the work function of lithium, stating an appropriate unit,

.....  
.....  
.....  
.....

answer .....  
(3 marks)

4 (c) (ii) Calculate the maximum kinetic energy of the emitted electrons when light of frequency  $6.2 \times 10^{14}$  Hz is incident on the surface of a sample of lithium.

.....  
.....  
.....  
.....  
.....  
.....

answer .....J  
(3 marks)

12





5 A student wishes to collect data so he can plot the  $I$ - $V$  curve for a semiconductor diode.

5 (a) (i) Draw a suitable diagram of the circuit that would enable the student to collect this data.

(3 marks)

5 (a) (ii) Describe the procedure the student would follow in order to obtain an  $I$ - $V$  curve for the semiconductor diode.

The quality of your written communication will be assessed in this question.

.....

.....

.....

.....

.....

.....

.....

.....

.....

.....

.....

.....

.....

.....

.....

.....

.....

.....

.....

.....

.....

.....

.....

(6 marks)

Turn over ▶



5 (b) **Figure 1** shows an arrangement of a semiconducting diode and two resistors.

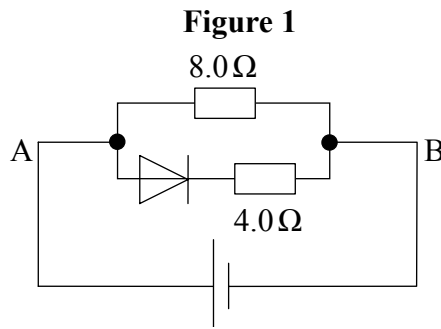

A 12.0 V battery is connected with its positive terminal to A and negative terminal to B.

5 (b) (i) Calculate the current in the 8.0Ω resistor

.....

.....

.....

answer .....A  
(2 marks)

5 (b) (ii) Calculate the current in the 4.0Ω resistor if the p.d. across the diode, when in forward bias, is 0.65 V expressing your answer to an appropriate number of significant figures.

.....

.....

.....

.....

answer .....A  
(3 marks)

**Turn over for the next question**



**Turn over for the next question**

**DO NOT WRITE ON THIS PAGE  
ANSWER IN THE SPACES PROVIDED**

**Turn over ▶**



6 **Figure 2** shows an ac waveform that is displayed on an oscilloscope screen.

**Figure 2**

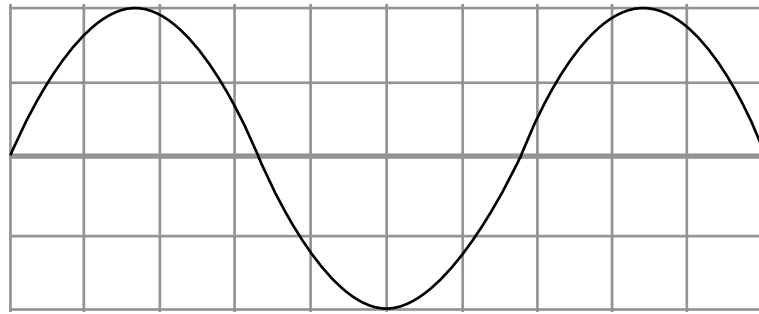

The time base of the oscilloscope is set at 1.5 ms per division and the y-gain at 1.5 V per division.

6 (a) For the ac waveform shown,

6 (a) (i) Calculate the frequency

.....

.....

.....

.....

answer ..... Hz  
(3 marks)

6 (a) (ii) Calculate the peak voltage

.....

.....

.....

.....

answer ..... V  
(2 marks)



6 (a) (iii) the rms voltage

.....  
.....  
.....  
.....

answer .....V  
(2 marks)

6 (b) State and explain the effect on the oscilloscope trace if the time base is switched off.

.....  
.....  
.....  
.....  
.....  
.....

(2 marks)

9

Turn over ▶



7 A car battery has an emf of 12 V and an internal resistance of  $9.5 \times 10^{-3} \Omega$ . When the battery is used to start a car the current through the battery is 420 A.

7 (a) Calculate the voltage across the terminals of the battery, when the current through the battery is 420 A.

.....  
 .....  
 .....  
 .....

answer .....V  
 (2 marks)

7 (b) The copper cable connecting the starter motor to the battery has a length of 0.75m and cross-sectional area of  $7.9 \times 10^{-5} \text{ m}^2$ . The resistance of the cable is  $1.6 \times 10^{-3} \Omega$ .

Calculate the resistivity of the copper giving an appropriate unit.

.....  
 .....  
 .....  
 .....  
 .....  
 .....

answer .....  
 (3 marks)

5
---

**END OF QUESTIONS**

