

Paper Reference(s)

6680/01

Edexcel GCE

Mechanics M4

Advanced Level

Thursday 15 June 2006 – Afternoon

Time: 1 hour 30 minutes

Materials required for examination

Mathematical Formulae (Green)

Items included with question papers

Nil

Candidates may use any calculator EXCEPT those with the facility for symbolic algebra, differentiation and/or integration. Thus candidates may NOT use calculators such as the Texas Instruments TI 89, TI 92, Casio CFX 9970G, Hewlett Packard HP 48G.

Instructions to Candidates

In the boxes on the answer book, write the name of the examining body (Edexcel), your centre number, candidate number, the unit title (Mechanics M4), the paper reference (6680), your surname, other name and signature.

Whenever a numerical value of g is required, take $g = 9.8 \text{ m s}^{-2}$.

When a calculator is used, the answer should be given to an appropriate degree of accuracy.

Information for Candidates

A booklet 'Mathematical Formulae and Statistical Tables' is provided.

Full marks may be obtained for answers to ALL questions.

The marks for individual questions and the parts of questions are shown in round brackets: e.g. (2).

There are 7 questions on this paper. The total mark for this paper is 75.

Advice to Candidates

You must ensure that your answers to parts of questions are clearly labelled.

You must show sufficient working to make your methods clear to the Examiner. Answers without working may gain no credit.

N22908RA

1. At noon, a boat P is on a bearing of 120° from boat Q . Boat P is moving due east at a constant speed of 12 km h^{-1} . Boat Q is moving in a straight line with a constant speed of 15 km h^{-1} on a course to intercept P . Find the direction of motion of Q , giving your answer as a bearing. (5)
-

2. A smooth uniform sphere S of mass m is moving on a smooth horizontal plane when it collides with a fixed smooth vertical wall. Immediately before the collision, the speed of S is U and its direction of motion makes an angle α with the wall. The coefficient of restitution between S and the wall is e . Find the kinetic energy of S immediately after the collision. (6)
-

3. A cyclist C is moving with a constant speed of 10 m s^{-1} due south. Cyclist D is moving with a constant speed of 16 m s^{-1} on a bearing of 240° .

(a) Show that the magnitude of the velocity of C relative to D is 14 m s^{-1} . (3)

At 2 pm, D is 4 km due east of C .

(b) Find

- (i) the shortest distance between C and D during the subsequent motion,
(ii) the time, to the nearest minute, at which this shortest distance occurs.

(7)

4.

Figure 1

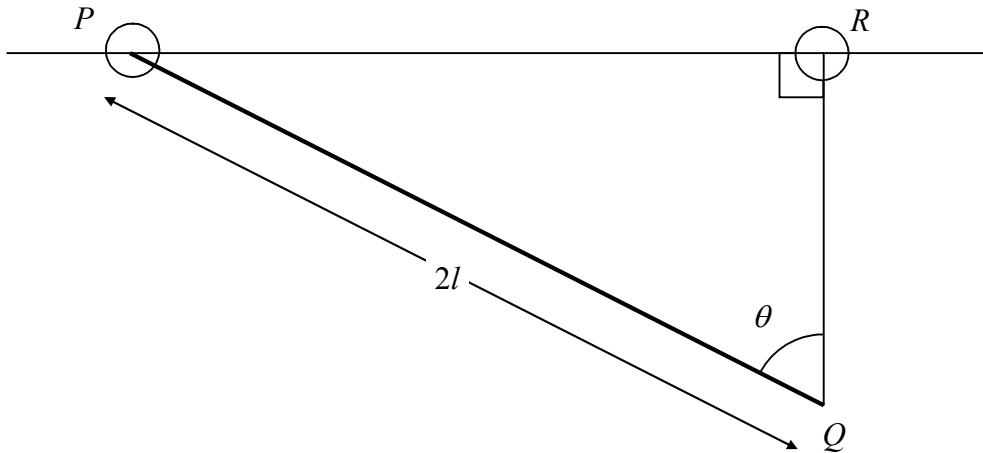

A uniform rod PQ has mass m and length $2l$. A small smooth light ring is fixed to the end P of the rod. This ring is threaded on to a fixed horizontal smooth straight wire. A second small smooth light ring R is threaded on to the wire and is attached by a light elastic string, of natural length l and modulus of elasticity kmg , to the end Q of the rod, where k is a constant.

- (a) Show that, when the rod PQ makes an angle θ with the vertical, where $0 < \theta \leq \frac{\pi}{3}$, and Q is vertically below R , as shown in Figure 1, the potential energy of the system is

$$mgl [2k \cos^2 \theta - (2k + 1) \cos \theta] + \text{constant}. \quad (7)$$

Given that there is a position of equilibrium with $\theta > 0$,

- (b) show that $k > \frac{1}{2}$. (5)

5. A train of mass m is moving along a straight horizontal railway line. A time t , the train is moving with speed v and the resistance to motion has magnitude kv , where k is a constant. The engine of the train is working at a constant rate P .

- (a) Show that, when $v > 0$, $mv \frac{dv}{dt} + kv^2 = P$. (3)

When $t = 0$, the speed of the train is $\frac{1}{3} \sqrt{\left(\frac{P}{k}\right)}$.

- (b) Find, in terms of m and k , the time taken for the train to double its initial speed. (8)

6.

Figure 2

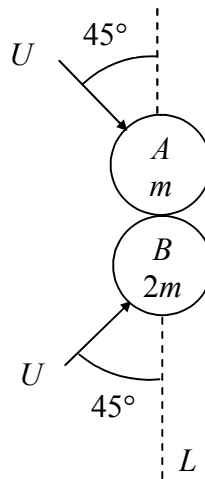

Two small smooth spheres A and B , of equal size and of mass m and $2m$ respectively, are moving initially with the same speed U on a smooth horizontal floor. The spheres collide when their centres are on a line L . Before the collision the spheres are moving towards each other, with their directions of motion perpendicular to each other and each inclined at an angle of 45° to the line L , as shown in Figure 2. The coefficient of restitution between the spheres is $\frac{1}{2}$.

(a) Find the magnitude of the impulse which acts on A in the collision.

(9)

Figure 3

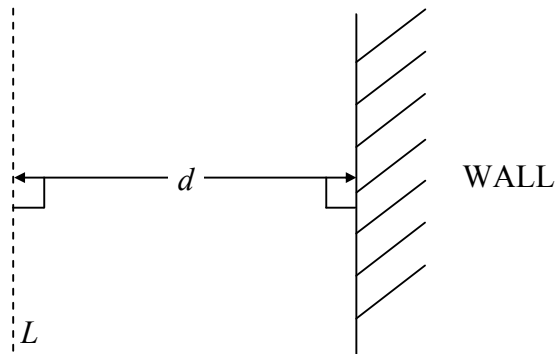

The line L is parallel to and a distance d from a smooth vertical wall, as shown in Figure 3.

(b) Find, in terms of d , the distance between the points at which the spheres first strike the wall.

(5)

7.

Figure 4

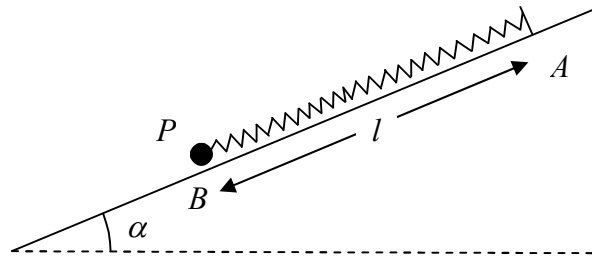

A light elastic spring has natural length l and modulus of elasticity $4mg$. One end of the spring is attached to a point A on a plane that is inclined to the horizontal at an angle α , where $\tan \alpha = \frac{3}{4}$. The other end of the spring is attached to a particle P of mass m . The plane is rough and the coefficient of friction between P and the plane is $\frac{1}{2}$. The particle P is held at a point B on the plane where B is below A and $AB = l$, with the spring lying along a line of greatest slope of the plane, as shown in Figure 4. At time $t = 0$, the particle is projected up the plane towards A with speed $\frac{1}{2}\sqrt{gl}$. At time t , the compression of the spring is x .

(a) Show that $\frac{d^2x}{dt^2} + 4\omega^2x = -g$, where $\omega = \sqrt{\left(\frac{g}{l}\right)}$. (6)

(b) Find x in terms of l , ω and t . (7)

(c) Find the distance that P travels up the plane before first coming to rest. (4)

TOTAL FOR PAPER: 75 MARKS

END