

Please write clearly, in block capitals.

Centre number

--	--	--	--	--

Candidate number

--	--	--	--

Surname

Forename(s)

Candidate signature

AS

FURTHER MATHEMATICS

Paper 1

Exam Date

Morning

Time allowed: 1 hour 30 minutes

Materials

For this paper you must have:

- The AQA booklet of formulae and statistical tables.
- You may use a graphics calculator.

Instructions

- Use black ink or black ball-point pen. Pencil should be used for drawing.
- Answer **all** questions.
- You must answer each question in the space provided for that question. If you require extra space, use an AQA supplementary answer book; do **not** use the space provided for a different question.
- Do not write outside the box around each page.
- Show all necessary working; otherwise marks for method may be lost.
- Do all rough work in this book. Cross through any work that you do not want to be marked.

Information

- The marks for questions are shown in brackets.
- The maximum mark for this paper is 80.

Advice

Unless stated otherwise, you may quote formulae, without proof, from the booklet. You do not necessarily need to use all the space provided.

Answer **all** questions in the spaces provided.

- 1 A reflection is represented by the matrix $\begin{bmatrix} 1 & 0 \\ 0 & -1 \end{bmatrix}$

State the equation of the line of invariant points.

Circle your answer.

[1 mark]

$x = 0$

$y = 0$

$y = x$

$y = -x$

- 2 Find the mean value of $3x^2$ over the interval $1 \leq x \leq 3$

Circle your answer.

[1 mark]

$8\frac{2}{3}$

10

13

26

- 3 Find the equations of the asymptotes of the curve $x^2 - 3y^2 = 1$

Circle your answer.

[1 mark]

$$y = \pm 3x$$

$$y = \pm \frac{1}{3}x$$

$$y = \pm \sqrt{3}x$$

$$y = \pm \frac{1}{\sqrt{3}}x$$

Turn over for the next question

- 7 A lighting engineer is setting up part of a display inside a large building. The diagram shows a plan view of the area in which he is working.

He has two lights, which project narrow beams of light.

One is set up at a point 3 metres above the point A and the beam from this light hits the wall 23 metres above the point D .

The other is set up 1 metre above the point B and the beam from this light hits the wall 29 metres above the point C .

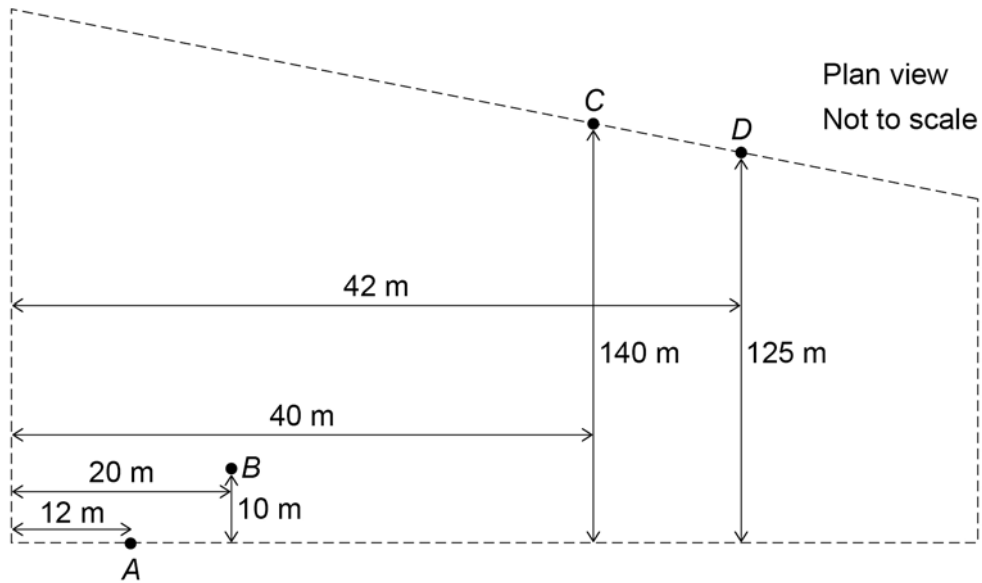

- 7 (a) By creating a suitable model, show that the beams of light intersect.

[6 marks]

8 A curve has polar equation $r = 3 + 2 \cos \theta$, where $0 \leq \theta < 2\pi$

8 (a) (i) State the maximum and minimum values of r .

[2 marks]

8 (a) (ii) Sketch the curve.

[2 marks]

O ————— \rightarrow Initial line

- 9 (a) Sketch on the Argand diagram below, the locus of points satisfying the equation $|z - 2| = 2$

[2 marks]

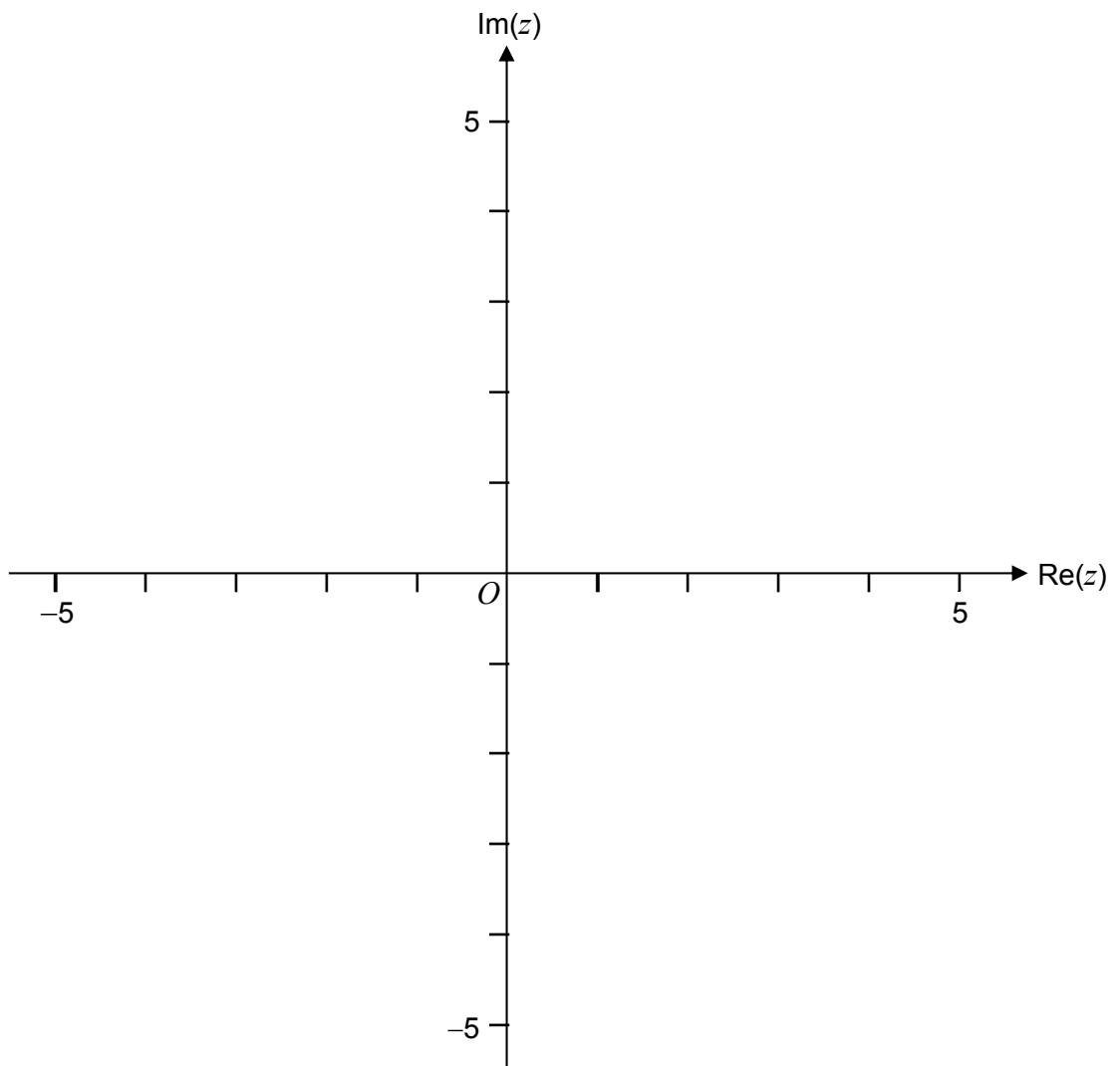

-
- 10 (b)** Alex substituted a few values of n into the expression $(n + 1)(n + 2)(n + 3)$ and made the statement:

“For all positive integers n ,

$$6 + 3 \sum_{r=1}^n (r + 1)(r + 2)$$

is divisible by 12.”

Disprove Alex’s statement.

[2 marks]

Turn over for the next question

-
- 12 (b)** Show that the curve C_2 whose equation is $y = \frac{1}{f(x)}$, has no vertical asymptotes.

[2 marks]

- 12 (c)** State the equation of the line that is a tangent to both C_1 and C_2 .

[1 mark]

END OF QUESTIONS