

# Edexcel GCE

## Engineering

### Unit 4: Applied Engineering Systems Candidate Brief

June 2011 Series

Paper Reference

**6934/01**

**You do not need any other materials.**

#### Advice to Candidates

- This brief is the **only** vehicle for the assessment of this unit.
- Apart from this document there will be **no examination paper** for this unit.
- Candidates' work must be carried out individually in a suitable environment, such as the workshop, and under strictly controlled/managed conditions.
- The three practical activities may be started at anytime after the brief has been published on the Edexcel website, at the centre's discretion.
- Candidates should spend no more than a total of ten hours in completing the three practical activities.
- You must enter your details and sign and date the candidate authentication document stating it is your own work.
- Task labelled with an asterisk (\*) is one where the quality of your written communication will be assessed.

#### Advice to Centre Staff

- The evidence to be submitted for assessment must demonstrate compliance with the requirements of the assessment criteria grid.
- Assessment will be carried out by centre assessors, whose decisions will be subject to moderation by Edexcel's external moderators. For this purpose, Edexcel will require a sample of the candidates' work and moderation will take place during the June examination series.
- The candidates' work must be completed, assessed and submitted to the designated moderator by the end of the published deadline.
- The candidates' mark must be entered on the appropriate OPTEMS forms and returned to Edexcel by the published deadline.
- **Centres should note that the marks and candidate work can only be submitted in the June examination series.**
- Centre staff must sign and date the candidate authentication document and return it with the candidate's work.
- Candidates' marks must be recorded on the Unit 4 Mark Record Sheet, which must be attached to the candidates' work when submitted to Edexcel for moderation. This form can be found on page 7 of the Candidate Brief.

Turn over ►

W38826A

©2011 Edexcel Limited.

5/4/4



edexcel   
advancing learning, changing lives

## Practical activity brief

### Activity 1

It is important for engineers to know the forces acting in members of load bearing structures and the strength of the materials from which they are made. In this activity you will be asked to carry out a destructive tensile test on a structural material to determine its load bearing properties. You will also be asked to analyse a loaded framed structure to determine how its members react and whether it is in a safe condition.

You are required to complete the following tasks and submit evidence of your work.

#### Task (a) (i)

Measure and record the behaviour of a sample of a known metal by subjecting a standard sample to a destructive tensile test.

Produce a load/extension graph for the metal and record the dimensions of the sample.

State the type of metal you have used.

#### Task (a) (ii)

Plot a graph of stress v strain and from it determine:

- the ultimate tensile strength of the metal
- the modulus of elasticity of the metal

Compare these values with the published data for the metal. (Note that it is quite reasonable for your values to vary by 20% or more from the known values, owing to factors such as slight variations in the composition of the metal.)

The supports of a roof are arranged as shown in Figure 1. They are made from solid rods of circular cross section of the metal you have tested. They are fixed at one end C to a wall and to rollers at end B. The rollers ensure that the reaction at B is vertical and you can assume that the other joints behave like pinned joints. The wind load at A is 1 tonne in a horizontal direction.

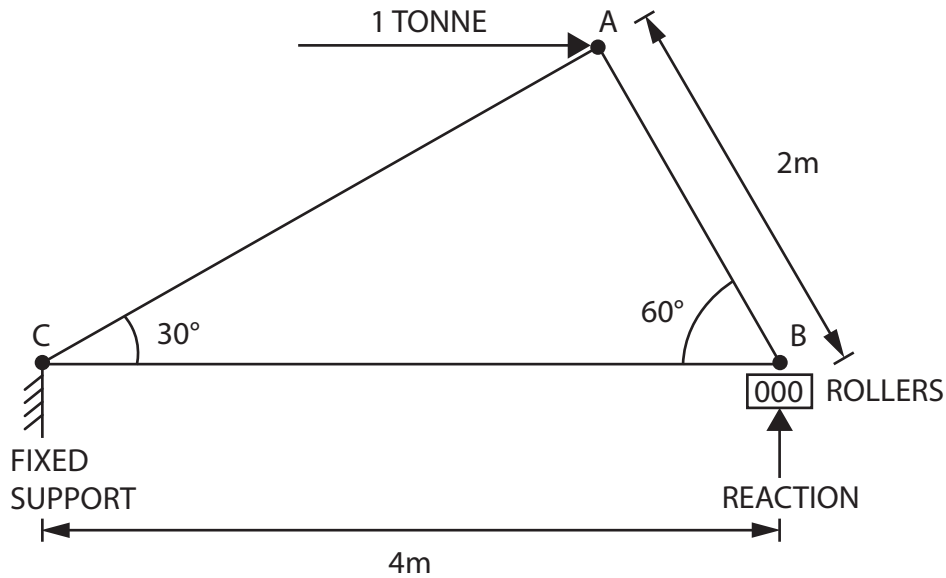

**Figure 1**

**Task (a) (iii)**

Determine the magnitudes and natures of the forces in all members of the structure.

**Task (a) (iv)**

Assuming a factor of safety of 8, for member AB calculate a suitable diameter for that member.

**Task (a) (v)**

Determine the change in dimensions of member AB as a result of the load. You may assume that the modulus of elasticity of the metal is the same in tension and compression.

**(Total for Activity 1 = 16 marks)**

## Activity 2

Electro-mechanical systems are to be found in everyday life. They include domestic appliances, power tools and some items of laboratory, workshop and office equipment. In this activity you will be asked to explain the function and investigate the design of an electro-mechanical system.

You are required to complete the following tasks and submit evidence of your work.

### Task (b)

The motor for a pillar drill takes an average current of 6A from a 230V 50Hz supply. It operates for 2.5 hours per day for 5 days per week.

- (i) Explain the function of the electric motor driving a pillar drill in a workshop. (2)
- (ii) State the formula you would use to calculate energy. (1)
- (iii) Calculate the weekly cost of running the motor if energy costs 13.24p/kWh. (3)

### Task (c)

The pillar drill is supplied from a wall-mounted distribution switchboard.

- (i) With the aid of a block diagram show the energy transfers which take place between the incoming supply and the drill bit. (4)
- (ii) Describe the energy losses that take place in the system, with reference to:
- electrical energy losses
  - mechanical energy losses
  - magnetic circuit losses
- (6)

### Task (d)

The motor of a pedestal drill rotates at a constant speed, but a range of output spindle speeds is available.

Explain how the range of output speeds is achieved.

Power circuits, such as those driving a pedestal drill, must be protected to keep them safe in use.

Name one method of circuit protection and describe how it protects the circuit. (6)

---

**(Total for Activity 2 = 22 marks)**

### Activity 3

Process variables such as temperature, pressure, speed, light intensity etc., often need to be monitored and controlled.

In this activity you are asked to design a suitable monitoring or control system which fulfils the requirements of the given design brief.

#### Design brief

Design a monitoring and measuring system for the speed of a drive motor. The system must have a digital display and give warnings when the speed exceeds a pre-set value which would indicate possible mechanical problems.

You are required to complete the following tasks and submit evidence of your work.

#### \*Task (e)

Produce a feasible design solution for the system which should include:

- a block diagram showing all system elements
- signal pathways, inputs and outputs
- a detailed explanation of how your system functions
- the requirements of the design brief, taking into account health and safety considerations
- details of the sensors, transducers, display equipment and associated circuits

(18)

#### Task (f)

Select suitable materials and components for your design which take into account:

- production constraints
- safety considerations

(4)

---

**(Total for Activity 3 = 22 marks)**

---

**TOTAL FOR PAPER = 60 MARKS**

## Authentication Statement

### Authentication Statement GCE Engineering External Test

The statement below **MUST** be completed for each candidate where a Unit Test specifies that a candidate's work must be handed in with the question paper. Failure to do so will result in the candidate receiving **zero marks** for the whole test.

<b>Unit Number</b>	6934
<b>Unit Name</b>	Applied Engineering Systems
<b>Level</b>	Advanced

### Candidate's Declaration

**I certify that the work submitted for this unit is my own.**

Name of Candidate		Date	
Signature of Candidate			

### Teacher's Declaration

**I certify that the candidate named above has completed the work submitted.**

Name of Teacher		Date	
Signature of Teacher			

## Appendix E: Edexcel GCE in Engineering – Unit 4 Mark Record Sheet

Centre no:

Centre name:

Internal moderator name:

Candidate no:

Candidate name:

Series number:

Unit 4: Applied Engineering Systems						Centre mark	Edexcel use only
Assessment evidence	Annotation and page number	Mark band					
		1	2	3			
(a)		0-8	9-12	13-16			
(b)		0-2	3-4	5-6			
(c)		0-4	5-7	8-10			
(d)		0-2	3-4	5-6			
(e)		0-9	10-14	15-18			
(f)		0-2	3	4			
<b>Final total</b>							

Edexcel moderator use only

AA number:

Name:

Signature:

**BLANK PAGE**