

ADVANCED GCE
DESIGN AND TECHNOLOGY
Product Design: Component 1

F524/01

* 6 7 0 1 0 2 5 2 4 0 1 *

Candidates answer on the question paper.

OCR supplied materials:
None

Other materials required:

- A calculator may be used

Wednesday 26 January 2011
Morning
Duration: 1 hour



| | | | |
|--------------------|--|-------------------|--|
| Candidate forename | | Candidate surname | |
|--------------------|--|-------------------|--|

| | | | | | | | | | | | |
|---------------|--|--|--|--|--|--|------------------|--|--|--|--|
| Centre number | | | | | | | Candidate number | | | | |
|---------------|--|--|--|--|--|--|------------------|--|--|--|--|

MODIFIED LANGUAGE

INSTRUCTIONS TO CANDIDATES

- Write your name clearly in capital letters, your Centre Number and Candidate Number in the boxes above.
- Use black ink. Pencil may be used for graphs and diagrams only.
- This paper is to be taken with F524/02 in the same examination session of **2 hours 30 minutes**. The times given on the front of each paper are advisory.
- Components 1 and 2 should be available to candidates for the full session.
- Answer **ONE** question only from component 1 and **ONE** question only from component 2.
- Component 1 and Component 2 choices can be from different material areas although it is envisaged that most candidates will select the same material area.
- Read each question carefully and make sure that you know what you have to do before starting your answer.
- Do **not** write in the bar codes.
- The discuss question will be used to assess the quality of written communication.
- Write your answer to each question in the space provided. Additional paper may be used if necessary but you must clearly show your Candidate Number, Centre Number and question number(s).

INFORMATION FOR CANDIDATES

- The number of marks is given in brackets [] at the end of each question or part question.
- The total number of marks for this paper is **36**.
- All dimensions are in mm.
- Where appropriate calculations should be shown.
- This document consists of **44** pages.
Any blank pages are indicated.

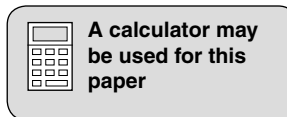

1 Built Environment and Construction

Fig. 1 shows a foundation.

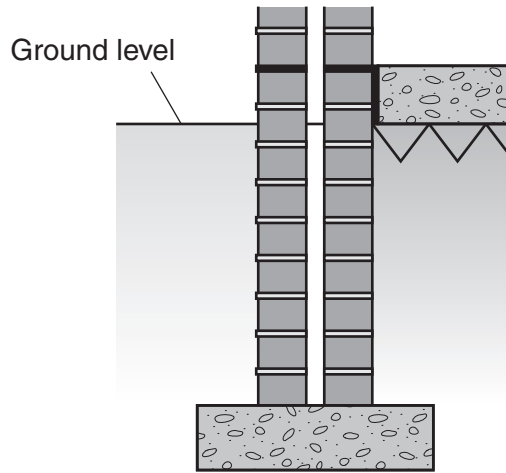

Fig. 1

(a) Give **four** design requirements for the foundation shown in Fig. 1. Justify each requirement.

- 1
- 2
- 3
- 4

[4]

- (e) (i) State a **suitable specific material** used in the construction of a foundation.
Give **two** properties or characteristics that make the material suitable for this use.

.....

.....

.....

.....

..... [3]

- (ii) Describe, in detail, the Site Preparation procedure used to aid the design and construction of a building.
Use a flowchart and/or annotated diagrams to support your answer.

2 Engineering

Fig. 2 shows a base for a garden parasol.

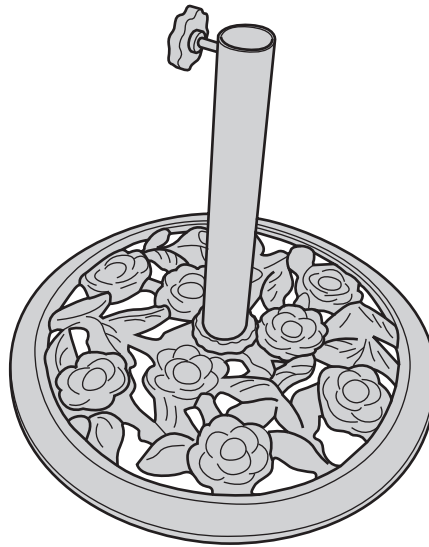

Fig. 2

(a) Give **four** design requirements for the parasol base shown in Fig. 2. Justify each requirement.

- 1
- 2
- 3
- 4

[4]

- (ii) Describe, in detail, how the connector shown in Fig. 3 would be manufactured and fixed into the support tube.
Include details of quality control checks that you would use.
Use a flowchart and/or annotated diagrams to support your answer.

[9]

11
BLANK PAGE

PLEASE DO NOT WRITE ON THIS PAGE

3 Food

Fig. 4 shows a frozen fish product.



Fig. 4

(a) Give **four** design requirements for the frozen fish product shown in Fig. 4. Justify each requirement.

- 1
 -
 - 2
 -
 - 3
 -
 - 4
 -
- [4]

(b) Describe **two** ways in which computers could be used for designing a food product.

- 1
 -
 -
 - 2
 -
 -
- [4]

(c) Explain **two** disadvantages of using computerised stock control systems in the Food Industry.

1

.....

.....

2

.....

.....

[4]

(d) Explain what the term 'Intellectual Property' means in relation to the Food Industry. Use **two** examples to support your answer.

.....

.....

.....

.....

.....

.....

.....

.....

.....

.....

[4]

(e) (i) Give **three** reasons why the UK Government recommend that we should include more fish in our diet.

1

.....

2

.....

3

.....

[3]

- (ii) Describe, in detail, how the frozen fish product in Fig. 4 would be manufactured. Include details of all processes and the scientific principles underlying the process. Do not include the packaging. Use a flowchart and/or annotated diagrams to support your answer.

[9]

4 Graphic Products

Fig. 5 shows a drinks carton.

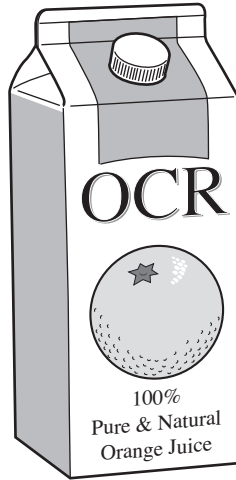

Fig. 5

(a) Give **four** design requirements for the drinks carton shown in Fig. 5. Justify each requirement.

- 1
- 2
- 3
- 4

[4]

- (e) (i) State a **suitable specific material** for the drinks carton shown in Fig. 5.
Give **two** properties or characteristics that make the material suitable for this use.

.....

.....

.....

.....

..... [3]

- (ii) Describe, in detail, how the drinks cartons shown in Fig. 5 would be manufactured as a batch of 500 000.
Do not include the plastic cap.
Use a flowchart and/or annotated diagrams to support your answer.

5 Manufacturing

Fig. 6 shows a folding picnic table.

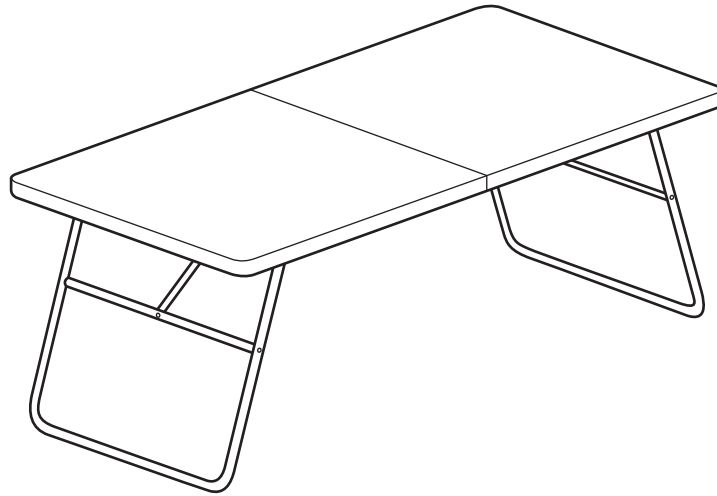

Fig. 6

(a) Give **four** design requirements for the picnic table shown in Fig. 6. Justify each requirement.

- 1
- 2
- 3
- 4

[4]

Fig. 7 shows one of the legs from the picnic table.

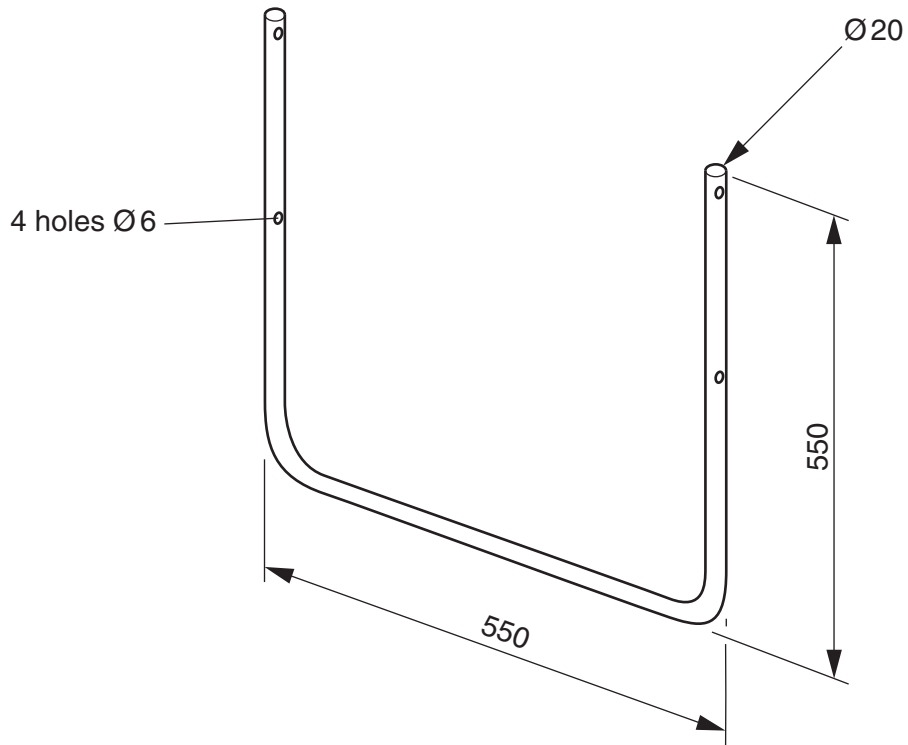

Fig. 7

- (e) (i) State a **suitable specific material** for the leg shown in Fig. 7. Give **two** properties or characteristics that make the material suitable for this use.

.....

.....

.....

.....

.....

..... [3]

- (ii) Describe, in detail, how the leg shown in Fig. 7 would be manufactured as a batch of 10 000.
Include details of any special equipment and quality control checks that would be used.
Use a flowchart and/or annotated diagrams to support your answer.

[9]

25
BLANK PAGE

PLEASE DO NOT WRITE ON THIS PAGE

6 Resistant materials

Fig. 8 shows a desk lamp.

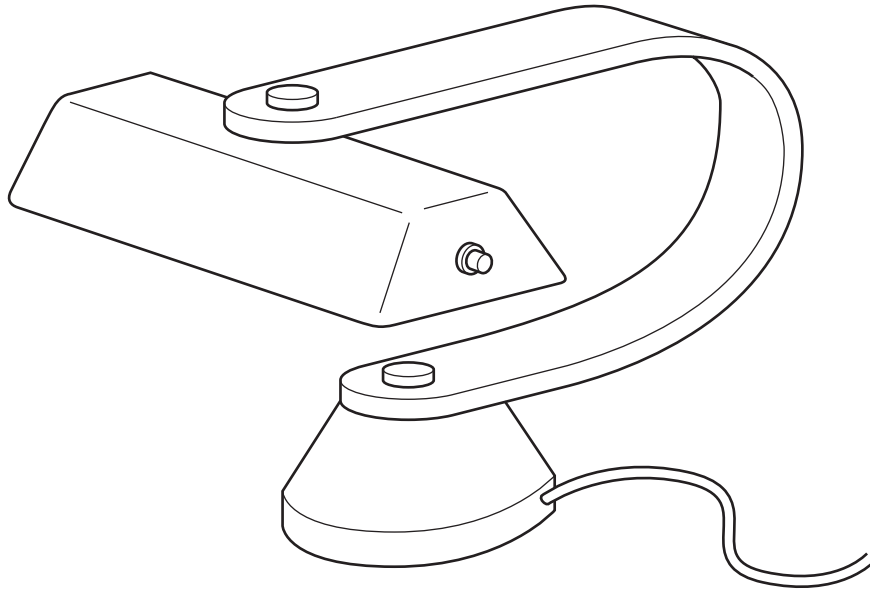

Fig. 8

(a) Give **four** design requirements for the desk lamp shown in Fig. 8. Justify each requirement.

- 1
- 2
- 3
- 4

[4]

(b) Describe **two** ways in which CAD can be used in designing a desk lamp.

1

.....

.....

2

.....

.....

[4]

(c) Explain **two** disadvantages of using computerised stock control systems in the manufacture of resistant material products.

1

.....

.....

2

.....

.....

[4]

(d) Explain what the term 'Intellectual Property' means in relation to resistant material products. Use **two** examples to support your answer.

.....

.....

.....

.....

.....

.....

.....

.....

.....

.....

.....

[4]

(e) Fig. 9 shows parts of the desk lamp.

A Shade

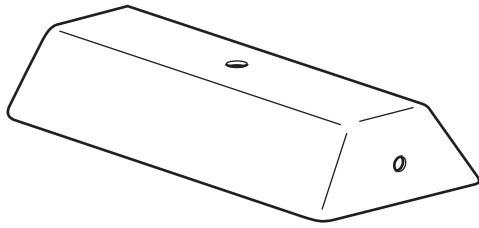

B Frame

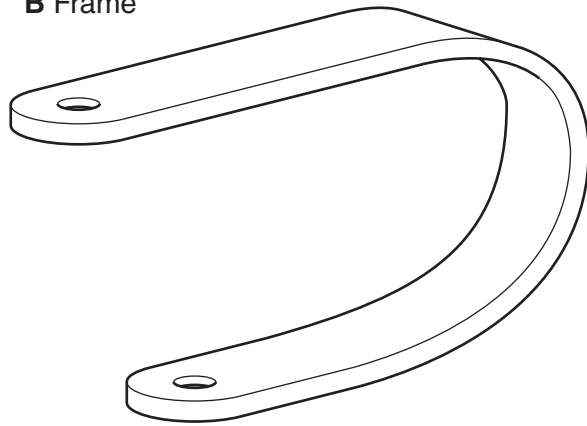

C Base

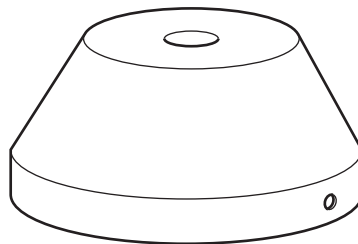

Fig. 9

Choose **one** of the parts shown in Fig. 9.

Chosen part

(i) State a **suitable specific material** for the part that you have chosen.
Give **two** properties or characteristics that make the material suitable for this use.

.....

.....

.....

.....

.....

.....

[3]

- (ii) Describe, in detail, how the part you have chosen would be manufactured as a batch of 50.
Include details of jigs, presses or formers.
Use a flowchart and/or annotated diagrams to support your answer.

[9]

31
BLANK PAGE

PLEASE DO NOT WRITE ON THIS PAGE

7 Systems and Control

Fig. 10 shows an electronic car tyre inflator.

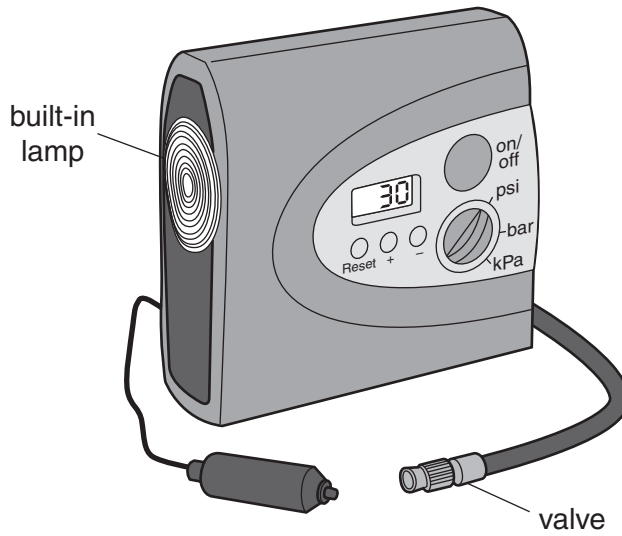

Fig. 10

(a) Give **four** design requirements for the electronic car tyre inflator shown in Fig. 10. Justify each requirement.

- 1
- 2
- 3
- 4

[4]

- (e) (i) The electronic car tyre inflator contains a DC motor.
Sketch a diagram to show how a DC motor could be used with other components to pump air under pressure into a tyre.

[3]

- (ii) The electronic car tyre inflator monitors the pressure of the air in the tyre and cuts off the motor when the pressure reaches a preset level.
Design an electronic system that will carry out this function.
Use annotated diagrams to support your answer.
Your answer should include a circuit diagram.

[9]

BLANK PAGE

PLEASE DO NOT WRITE ON THIS PAGE

8 Textiles

Fig. 11 shows a pair of children's dungarees.

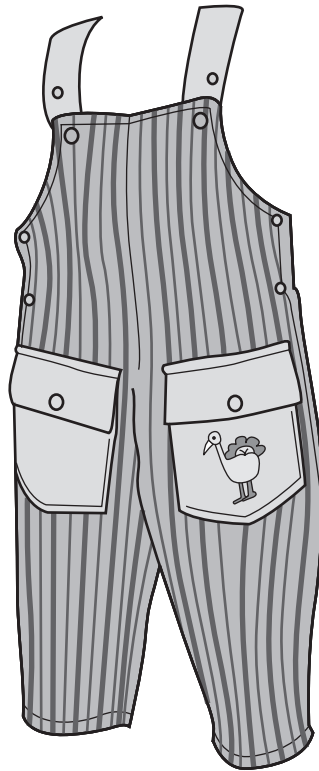

Fig. 11

(a) Give **four** design requirements for the children's dungarees shown in Fig. 11. Justify each requirement.

- 1
- 2
- 3
- 4

[4]

(b) Describe **two** ways in which CAD can be used in designing dungarees.

1

.....

.....

2

.....

..... [4]

(c) Explain **two** disadvantages of using computerised stock control systems in the Textiles Industry.

1

.....

.....

2

.....

..... [4]

(d) Explain what the term 'Intellectual Property' means in relation to textile products. Use **two** examples to support your answer.

.....

.....

.....

.....

.....

.....

.....

.....

.....

..... [4]

- (e) (i) State a **suitable specific fabric** for the children’s dungarees as shown in Fig. 11. Give **two** performance characteristics that make the fabric suitable for this use.

.....

.....

.....

.....

..... [3]

- (ii) The children’s dungarees shown in Fig. 11 have patch pockets with an embroidered design. Describe, in detail, how the pockets would be manufactured and attached to the dungarees in a batch of 500. Use a flowchart and/or annotated diagrams to support your answer.

PLEASE DO NOT WRITE ON THIS PAGE

PLEASE DO NOT WRITE ON THIS PAGE

PLEASE DO NOT WRITE ON THIS PAGE



Copyright Information

OCR is committed to seeking permission to reproduce all third-party content that it uses in its assessment materials. OCR has attempted to identify and contact all copyright holders whose work is used in this paper. To avoid the issue of disclosure of answer-related information to candidates, all copyright acknowledgements are reproduced in the OCR Copyright Acknowledgements Booklet. This is produced for each series of examinations and is freely available to download from our public website (www.ocr.org.uk) after the live examination series.

If OCR has unwittingly failed to correctly acknowledge or clear any third-party content in this assessment material, OCR will be happy to correct its mistake at the earliest possible opportunity.

For queries or further information please contact the Copyright Team, First Floor, 9 Hills Road, Cambridge CB2 1GE.

OCR is part of the Cambridge Assessment Group; Cambridge Assessment is the brand name of University of Cambridge Local Examinations Syndicate (UCLES), which is itself a department of the University of Cambridge.