



Cambridge International Examinations
Cambridge International Advanced Subsidiary Level and Advanced Level

CANDIDATE NAME

CENTRE NUMBER

CANDIDATE NUMBER

* 7 4 9 7 0 2 8 8 5 7 *

COMPUTING **9691/13**
Paper 1 **May/June 2014**
1 hour 30 minutes

Candidates answer on the Question Paper.
No additional materials are required.
No calculators allowed.

READ THESE INSTRUCTIONS FIRST

Write your Centre number, candidate number and name on all the work you hand in.
Write in dark blue or black pen.
You may use an HB pencil for any diagrams, graphs or rough working.
Do not use staples, paper clips, glue or correction fluid.
DO NOT WRITE IN ANY BARCODES.

Answer **all** questions.
No marks will be awarded for using brand names for software packages or hardware.

At the end of the examination, fasten all your work securely together.
The number of marks is given in brackets [] at the end of each question or part question.

This document consists of **14** printed pages and **2** blank pages.

- 1 The following diagram shows **five** questions on the left and **eight** numerical values on the right. Draw arrows to connect each question to the correct numerical value.

10

How many bits are there in 3 bytes of data?

12

If 2^x bytes = 1 kilobyte, what is the value of x?

14

If the binary pattern 00010010 represents a positive integer, what is its denary value?

16

How many possible binary input combinations are there in a 4-input logic circuit?

18

The next change to the stack is to remove an item.

Which one?

14
18
20

20

22

24

[5]

- 2 (a) Describe how buffers and interrupts are used when printing a large document stored on a hard drive.

.....
.....
.....
.....
.....
.....
.....
.....
.....
..... [4]

- (b) Data from a computer are sent to peripherals by using either serial or parallel data transmission.

Explain the difference between serial data transmission and parallel data transmission.

.....
.....
.....
.....
..... [2]

3 A pharmaceutical company uses computer control systems. The company has employed a systems analyst to modernise these systems.

(a) One stage in the analysis is **fact finding**.

Name and describe **two** fact finding techniques suitable for this application.

technique 1

description

.....

technique 2

description

..... [2]

(b) At the design stage, diagrams are used.

Describe the function of the following diagrams in the design process.

dataflow diagram (DFD)

.....

.....

.....

system flowchart

.....

.....

..... [4]

(c) **Technical documentation** is also produced as part of the system's development.

State **two** items you would expect to find in technical documentation.

1

2

[2]

4 A supermarket uses barcodes on all its products.

(a) When products pass through the point-of-sale (POS), various data are captured.

Name **three** suitable input devices at the POS.

input device 1

input device 2

input device 3 [3]

(b) Describe how the data captured at the POS are used in the automatic stock control system. Include in your answer how the system decides when to order new stock automatically.

.....

.....

.....

.....

.....

.....

.....

.....

.....

.....

.....

..... [4]

(c) The wages department at the supermarket runs the payroll program and produces employee wage slips each month. The payroll program uses **batch processing**.

(i) State what is meant by batch processing.

.....

..... [1]

(ii) Describe why batch processing is used in this application.

.....

.....

.....

.....

.....

..... [2]

5 A company issues a plastic card security pass to each of its workers. The pass consists of a photograph and a 10-digit security number stored on a magnetic stripe.

(a) When a worker arrives at the workplace, he inserts his card into a device at the gate and the magnetic stripe is read. The photograph is also scanned. He then looks up at a digital camera which also records his face pattern. The system is controlled by a computer.

(i) Explain how the system confirms that the worker is allowed access.

.....
.....
.....
.....
.....
..... [3]

(ii) Name and describe **two** validation checks that could be carried out on the 10-digit security number.

validation check 1
description
.....
validation check 2
description
..... [2]

(b) A card was recently stolen and a new photograph attached to the card.

Describe what additional security measures could be implemented to prevent this card allowing entry at the gate.

.....
.....
.....
..... [2]

6 (a) Describe the difference between a command line interface (CLI) and a graphical user interface (GUI).

.....
.....
.....
..... [2]

(b) CLI and GUI interfaces have advantages to certain users. Describe which type of user would find each of the interfaces the most useful. Justify your choice.

CLI

.....
.....

GUI

.....
..... [2]

(c) To enable a disabled person to communicate with a computer system, explain how the user interface could be modified. In your answer include:

- the disability you are considering
- how the modified interface will help overcome the disability.

.....
.....
.....
.....
.....
.....
.....
.....
.....
..... [4]

- 7 (a) A communication line uses half duplex.

State what is meant by half duplex.

.....
 [1]

- (b) A computer system uses **even parity**. The leftmost position of each byte is the parity bit.

- (i) Complete the byte below:

	1	0	1	0	0	0	1
--	---	---	---	---	---	---	---

[1]

- (ii) The parity bit is used to perform a parity check when a byte is transmitted from computer **A** to computer **B**.

Explain how computer **B** will establish whether or not the byte has been transmitted correctly.

.....

 [2]

- (c) In addition to a parity bit check on a byte, a parity block check is also carried out. Computer **A** transmits four bytes followed by a parity byte. The following sequence of bytes has just been received by computer **B**.

```

1 0 1 1 0 1 1 1
0 1 1 1 1 0 0 0
0 0 0 1 1 0 1 0
0 1 1 1 0 0 0 1
-----
1 0 1 0 1 1 0 0 ← parity byte
-----

```

One of the four bytes has an error in one of the bits.

- (i) Identify the byte where the error has occurred with an arrow.
 Circle the bit that has been altered.

[2]

- (ii) Write down the corrected byte:

--	--	--	--	--	--	--	--

[1]

(iii) Explain what the computer system needs to do if more than 1 bit has been transmitted wrongly.

.....

.....

.....

..... [2]

8 (a) Complete the truth table for the following logic circuit:

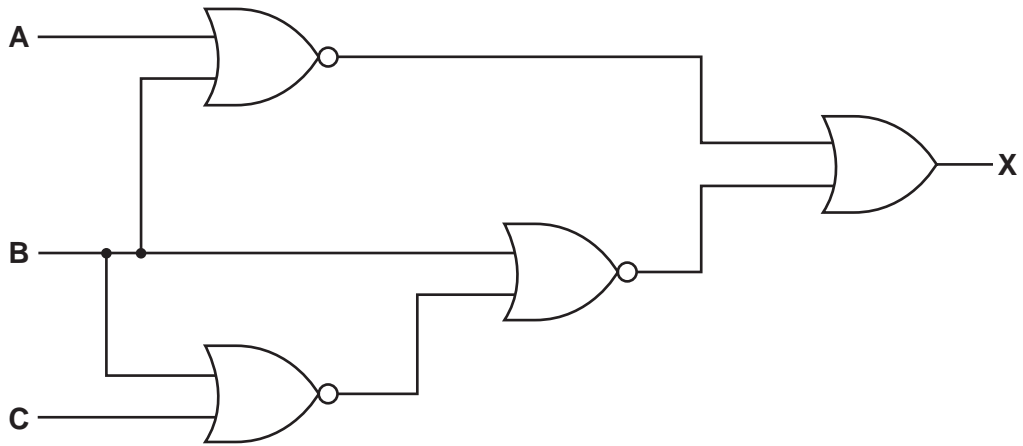

A	B	C	working	X
0	0	0		
0	0	1		
0	1	0		
0	1	1		
1	0	0		
1	0	1		
1	1	0		
1	1	1		

[4]

(b) Draw a logic circuit corresponding to the following logic statement:

$X = 1$ if ($A = \text{NOT } 1$ OR $B = 1$) AND ($B = \text{NOT } 1$ AND $C = \text{NOT } 1$)

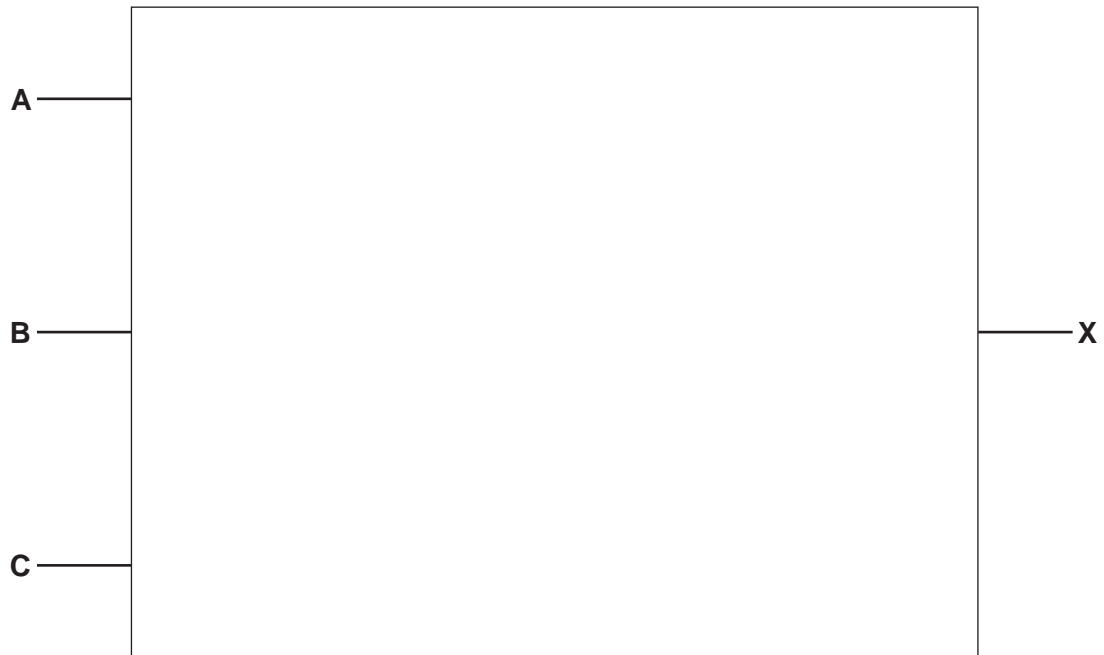

[6]

- 9 A tall office building has 60 floors. The building has 22 lifts (elevators), which operate between these floors. A computer is used to ensure efficient use of these lifts.

Each lift has its status stored in its own 12-bit register.



- The leftmost 5 bits represent the lift number.
- The next 6 bits represent the floor level where the lift is currently located.
- The rightmost bit represents whether the lift is going up (1) or going down (0).

(a) The register for one particular lift contains the following values:

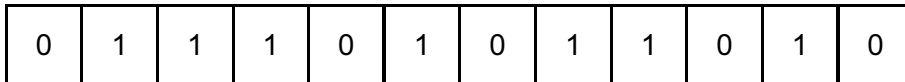

In each case below, give the information being represented.

lift number (in denary)

current floor level (in denary)

lift going up or down [3]

(b) State what the register for lift 17 would contain if it is currently on the 25th floor and is going up.



[3]

- (c) (i) A member of staff is on the 11th floor and wishes to go up. She presses the “up” button next to the lifts.

Identify the criteria the computer program will use to determine which lift should be sent to the 11th floor.

.....

.....

.....

.....

..... [2]

- (ii) Which of the following four lifts (A, B, C, D) should be chosen by the computer program to go to the 11th floor to allow the member of staff to go up? Give a reason for your choice.

0	1	1	1	1	0	0	1	0	0	1	0	A
0	0	0	1	1	0	0	1	1	1	0	1	B
1	0	0	1	0	0	0	0	1	0	0	1	C
0	1	0	0	0	0	0	0	1	1	1	0	D

lift

.....

reason for choice

..... [2]

(d) The member of staff gets into the lift and selects the 40th floor.

A second person gets in this lift at the 20th floor and selects the 28th floor and a third person gets in the lift at the 24th floor and selects the 38th floor.

The destination floors are now 40, 28 and 38.

Explain how the computer program ensures that the lift stops at the floors in the correct logical sequence.

.....

.....

.....

.....

.....

..... [2]

BLANK PAGE

Permission to reproduce items where third-party owned material protected by copyright is included has been sought and cleared where possible. Every reasonable effort has been made by the publisher (UCLES) to trace copyright holders, but if any items requiring clearance have unwittingly been included, the publisher will be pleased to make amends at the earliest possible opportunity.

Cambridge International Examinations is part of the Cambridge Assessment Group. Cambridge Assessment is the brand name of University of Cambridge Local Examinations Syndicate (UCLES), which is itself a department of the University of Cambridge.