



UNIVERSITY OF CAMBRIDGE INTERNATIONAL EXAMINATIONS  
 General Certificate of Education  
 Advanced Subsidiary Level and Advanced Level

CANDIDATE  
 NAME

CENTRE  
 NUMBER

--	--	--	--	--

CANDIDATE  
 NUMBER

--	--	--	--

\* 5 0 4 0 4 4 5 4 5 5 8 \*

**COMPUTING**

**9691/11**

Paper 1

**May/June 2012**

**1 hour 30 minutes**

Candidates answer on the Question Paper.

No additional materials are required.

No calculators allowed.

**READ THESE INSTRUCTIONS FIRST**

Write your Centre number, candidate number and name on all the work you hand in.

Write in dark blue or black pen.

You may use a soft pencil for any diagrams, graphs or rough working.

Do not use staples, paper clips, highlighters, glue or correction fluid.

**DO NOT WRITE IN ANY BARCODES.**

Answer **all** questions.

No marks will be awarded for using brand names for software packages or hardware.

At the end of the examination, fasten all your work securely together.

The number of marks is given in brackets [ ] at the end of each question or part question.

This document consists of **10** printed pages and **2** blank pages.



1 (a) (i) Give **two** differences between ROM (Read Only Memory) and RAM (Random Access Memory).

1 .....

.....

2 .....

..... [2]

(ii) State a program stored in ROM, giving a reason why it must be stored in ROM.

Program .....

Reason .....

.....

..... [2]

(iii) State the purpose of this program.

.....

..... [1]

(b) Define what is meant by:

(i) an input device

.....

..... [1]

(ii) an output device

.....

..... [1]

(c) A local hockey league is run by a secretary from home. The secretary is responsible for all fixtures and league tables.

The secretary is blind and uses her home computer for carrying out the necessary tasks.

State a suitable hardware peripheral for each of input, output and storage, which the secretary could use. Justify your choices.

*For  
Examiner's  
Use*

Input .....

Justification .....

.....

Output .....

Justification .....

.....

Storage .....

Justification .....

..... [6]

2 (a) Define the following types of software:

(i) operating system

.....  
..... [1]

(ii) applications software

.....  
..... [1]

(b) (i) Explain the difference between custom-written software and off-the-shelf software.

.....  
.....  
.....  
..... [2]

(ii) Explain **four** advantages of using off-the-shelf software.

.....  
.....  
.....  
.....  
.....  
.....  
.....  
..... [4]

(c) A student is completing a project for submission to the Geography department about rainfall in their area.

Explain how the student could use the following software:

(i) word processor

.....  
..... [1]

(ii) spreadsheet

.....  
..... [1]

(iii) desktop publishing

.....  
..... [1]

(d) The student uses a single-user, multi-tasking operating system.  
Describe what is meant by a single-user, multi-tasking operating system.

.....  
.....  
.....  
.....  
.....  
.....  
.....  
.....  
..... [4]

3 (i) State what is meant by a real-time operating system.

.....  
..... [1]

(ii) Describe an application which needs to be carried out in real time.

.....  
..... [1]

(iii) Explain why your choice needs to be a real-time application.

.....  
.....  
.....  
..... [2]

4 Describe the following methods of automated data capture. Give an example, in each case, of an application where it would be used.

(i) Optical Mark Recognition (OMR)

.....  
.....  
.....  
.....  
.....  
..... [3]

(ii) Optical Character Recognition (OCR)

.....  
.....  
.....  
.....  
..... [3]



- 7 (a) (i) Change the denary integer 278 into a binary number, using 10 bits.

.....  
 ..... [1]

- (ii) Change the binary number 10101100 into a positive denary integer.

.....  
 ..... [1]

- (b) A school stores data about the courses offered. A program which uses this data declares the following variables and data types:

**CourseName** as a **String**  
**CourseLevel** as a **Character**  
**StartDate** as a **Date**

- (i) "Computing" would be an appropriate value to be stored in **CourseName**.  
 Give a value appropriate to each of the other two variables:

**CourseLevel** .....

**StartDate** ..... [2]

- (ii) The table shows three fields that are used in the records for data stored about students.  
 Give the data type for each field. Give a reason for your choice in each case.

Field name	Data type	Reason
<b>StudentName</b>		
<b>NumberOfPrizesWon</b>		
<b>AverageExaminationMark</b>		

[6]



8 (a) The manager of a firm has been advised to link all the firm's computers to form a Local Area Network (LAN).

(i) Explain to the manager **two** benefits of connecting the computers in a LAN.

Benefit 1 .....

Benefit 2 ..... [2]

(ii) One computer is connected to its own printer using parallel data transmission. Explain what is meant by parallel data transmission.

..... [2]

(b) Explain the difference between packet switching and circuit switching. Give **one** advantage and **one** disadvantage of each.

Packet switching

Advantage .....

Disadvantage .....

Circuit switching

Advantage .....

Disadvantage ..... [6]

- 9 (a) Complete the truth table to show the output from the logic gate shown.

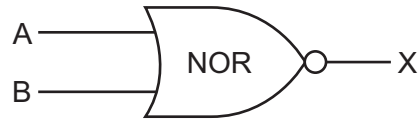

A	B	X
0	0	
0	1	
1	0	
1	1	

[2]

- (b) Complete the truth table to show the outputs from the logic circuit shown.

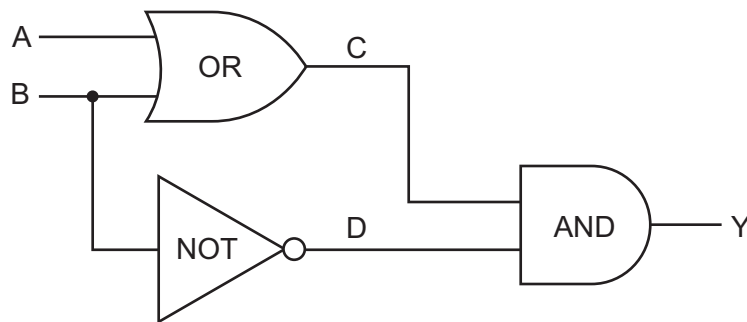

A	B	C	D	Y
0	0			
0	1			
1	0			
1	1			

[4]



**BLANK PAGE**

---

Permission to reproduce items where third-party owned material protected by copyright is included has been sought and cleared where possible. Every reasonable effort has been made by the publisher (UCLES) to trace copyright holders, but if any items requiring clearance have unwittingly been included, the publisher will be pleased to make amends at the earliest possible opportunity.

University of Cambridge International Examinations is part of the Cambridge Assessment Group. Cambridge Assessment is the brand name of University of Cambridge Local Examinations Syndicate (UCLES), which is itself a department of the University of Cambridge.