



*Rewarding Learning*

**ADVANCED SUBSIDIARY (AS)  
General Certificate of Education  
2016**

---

## **Technology and Design**

**Assessment Unit AS 1**

*assessing*

**Product Design and Systems and Control**

**[AV111]**

**FRIDAY 10 JUNE, MORNING**

---

**MARK  
SCHEME**

## **General Marking Instructions**

These mark schemes are intended to ensure that the AS/A2 examinations are marked consistently and fairly. The mark schemes provide examiners with an indication of the nature and range of candidate responses likely to be worthy of credit. They also set out the criteria which they should apply in allocating marks to candidates' responses. The mark schemes should be read in conjunction with these general marking instructions which apply to all papers.

### **Quality of candidates' responses**

In marking the examination papers, examiners will be looking for a quality of response reflecting the level of maturity which may reasonably be expected of 17- and 18-year-olds which is the age at which the majority of candidates sit their AS/A2 examinations.

### **Flexibility in marking**

The mark schemes which accompany the specimen examination papers are not intended to be totally prescriptive. For many questions, there may be a number of equally legitimate responses and different methods by which the candidates may achieve good marks. No mark scheme can cover all the answers which candidates may produce. In the event of unanticipated answers, examiners are expected to use their professional judgement to assess the validity of answers. If an answer is particularly problematic, then examiners should seek the guidance of the Supervising Examiner for the paper concerned.

### **Positive marking**

Examiners are encouraged to be positive in their marking, giving appropriate credit for valid responses rather than penalising candidates for errors or omissions. Examiners should make use of the whole of the available mark range for any particular question and be prepared to award full marks for a response which is as good as might reasonably be expected for 17- and 18-year-old candidates. Conversely, marks should only be awarded for valid responses and not given for an attempt which is completely incorrect and inappropriate.

### **Types of mark schemes**

Mark schemes for questions which required candidates to respond in extended written form are marked on the basis of levels of response which take account of the quality of written communication. These questions are indicated on the cover of the examination paper.

Other questions which require only short answers are marked on a point for point basis with marks awarded for each valid piece of information provided.

### **Quality of written communication**

Quality of written communication is taken into account in assessing candidates' responses to all questions that require them to respond in extended written form. These questions are marked on the basis of levels of response.

## Levels of response

Questions requiring extended written answers are marked in terms of levels of response. In deciding which mark within a particular level to award any response, examiners are expected to use their professional judgement. The following guidance is provided to assist examiners.

**Threshold performance:** Response which just merits inclusion in the level and should be awarded a mark at or near the bottom of the range.

**Intermediate performance:** Response which clearly merits inclusion in the level and should be awarded a mark at or near the middle of the range.

**High performance:** Response which fully satisfies the level description and should be awarded a mark at or near the top of the range.

In all cases, correct alternative responses will be given full credit.

AVAILABLE  
MARKS

Section A

1	(i) Any <b>one</b> specific example of a physical property, for example: <ul style="list-style-type: none"> <li>• Density.</li> <li>• Electrical conductivity.</li> </ul>	[1]	
	(ii) Any <b>one</b> specific example of a mechanical property, for example: <ul style="list-style-type: none"> <li>• Strength.</li> <li>• Elasticity.</li> </ul>	[1]	
	(iii) The scale of production required will influence the selection of the manufacturing processes to meet the perceived demands. In turn the manufacturing process may restrict the range of materials and hence the selection.	[2]	4
2	(i) Any <b>two</b> main properties of plywood that make it suitable for furniture, for example: <ul style="list-style-type: none"> <li>• Very good strength to weight ratio.</li> <li>• High impact resistance.</li> <li>• Good resistance to chemical cleaning products.</li> </ul>	[2]	
	(ii) Knock down fittings – annotated sketch showing blocks or brackets assembled with screws using screwdriver or specialised key design.	[3]	5
3	(i) Any <b>two</b> main properties of nylon which make it suitable for clothing, for example: <ul style="list-style-type: none"> <li>• Very durable.</li> <li>• Tough.</li> <li>• Resilient to wear.</li> </ul>	[2]	
	(ii) Any <b>two</b> main properties of brass which make it suitable for musical instruments, for example: <ul style="list-style-type: none"> <li>• Good malleability.</li> <li>• Good corrosion resistance.</li> <li>• Good acoustic properties.</li> </ul>	[2]	4
4	(i) <ul style="list-style-type: none"> <li>• Wasting – is the process of taking something away from a material.</li> <li>• Forming – is the process which results in a change of shape without adding or removing material.</li> <li>• Moulding – is the process which results in a change of shape with the aid of a mould using solid or molten material.</li> </ul>	[3]	
	(ii) Annotated sketch of the blanking process to include the Punch. Sheet material and die. Description.	[1] [1] [1]	6

- 5 (i) The difference between permanent and semi-permanent methods used to join materials.

Permanent joining methods (e.g. welding) are used with the expectation that the components will not be disassembled during their life cycle. Semi-permanent joining methods (e.g. nuts and bolts) facilitate disassembly during life cycle. [2]

- (ii) Riveting – annotated sketches showing the trapping together of two pieces of metal to be joined using rivets. [3]

- 6 (i) Any **two** main characteristics associated with cell production for example:
- Individual cell has responsibility for every aspect of the production of the component.
  - Operates as separate units within a large manufacturing plant.
  - Numbers of people in cells can vary and it is essential that all members of the cell work as a team. [2]

- (ii) The term ‘factor of safety of the frame’ – is the safety margin (factor) that the designer has allowed for in the design above the level which the frame would normally be expected to withstand. [2]

For a response not worthy of credit	[0]
Limited explanation and use of English grammar	[1]
Clear and coherent explanation using good English grammar.	[2]

Quality of written communication [2]

- 7 (i) Any **one** main advantage associated with computer-aided design (CAD) for example:
- Designs can be easily viewed in 3D, stored, edited and copied.
  - Designs can be easily shared or exported for rapid prototyping or manufacture. [1]

- (ii) Any **two** specific characteristics associated with solid modelling, for example:
- Computer based pictorial views provided.
  - Contains information about the volume and mass of the object.
  - Suitable for section views. [2]

- (iii) Any **two** specific characteristics associated with virtual imaging, for example:
- Three dimensional views of products on screen.
  - Images can be manipulated on-screen to give sense of realism.
  - Quick, interactive with client. [2]

AVAILABLE MARKS

5

6

5

- 8 (i) The term life cycle analysis means the analysis of a product in terms of its energy consumption, use of raw materials, waste, emissions and by-products from its conception through manufacture, distribution and use, to its recycling or disposal. [2]
- (ii) The term quality assurance (QA) refers to the setting and meeting of standards for every stage of the product from the design through to the after sales care. [2]
- Any **one** main reason why a company would need to consider it, for example:
- Companies which comply with the standards receive an ISO 9000 award which may contribute to improved sales figures.
  - With appropriate QA procedures and the ISO 9000 award the general public may be more confident in the quality of the product and the standard of the company. [1]

**Section A**

**AVAILABLE  
MARKS**

5

**40**

Section B

AVAILABLE MARKS

9 (a) (i)

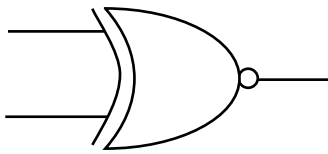

[1]

(ii)

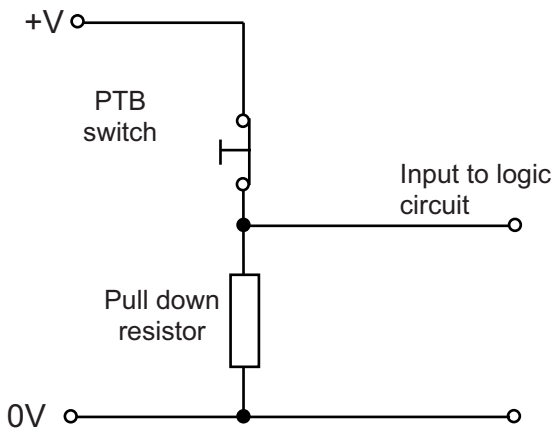

[2]

(iii) Truth table

1,  
1,  
0.

[3]

(b) (i)

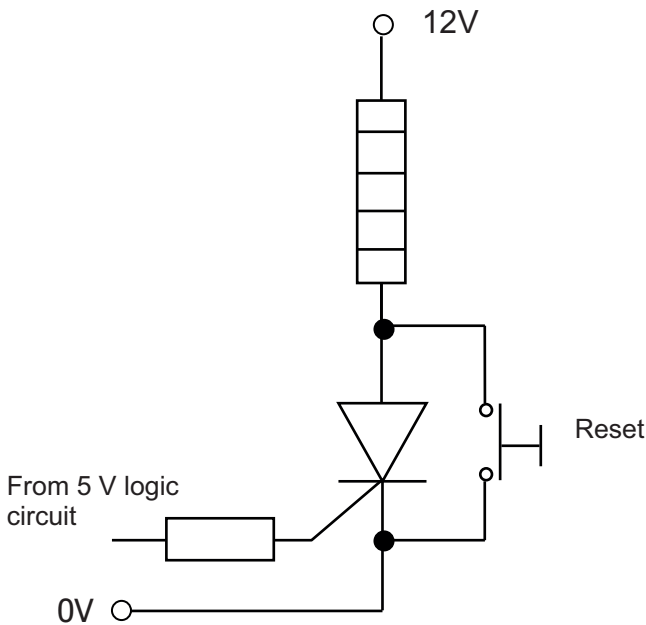

[4]

(ii)  $12/60 = 200\text{mA}$ .  $200\text{mA} \times 12\text{V} = 2.4\text{W}$

[2]

(iii) Sample answer likely to refer to any two of the following:

1. Using a programmable system such as a PIC can reduce the number of ICs required since many circuit output functions can be generated using the software. (Fig.1 would require 2 ICs). This can allow for smaller circuit boards.
2. PICs generally have multiple and/or flexible inputs and outputs whereas most dedicated integrated circuits such as those required for Fig.1 have fixed number of inputs and outputs. Additionally the PIC inputs can cope with different types of signals.

3. PIC circuits allow for greater flexibility when changes or adjustments need to be made to the logic system. This can be achieved by quickly programming the system rather than rewiring the gates. [2]

For a response not worthy of credit	[0]
Clear and coherent explanation using good English grammar.	[1]

Quality of written communication [1]

(c) (i) When S is logic 1 Q = 0 and when R = 0 then  $\bar{Q} = 1$  [2]

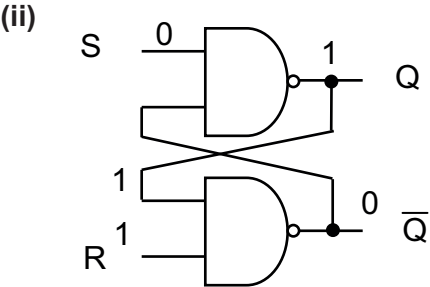

[1]

Description of latching action, e.g. if S is logic 0 then Q = 1, this is a stable state. If S then changes to logic 1 Q will remain at logic 1 meaning that the S input is effectively latched. Q can only be 'reset' by applying a logic 0 to the R input. [2]

20

10 (a) (i) The term 'negative temperature coefficient' refers to the characteristic of the thermistor where the resistance increases as the temperature decreases. [1]

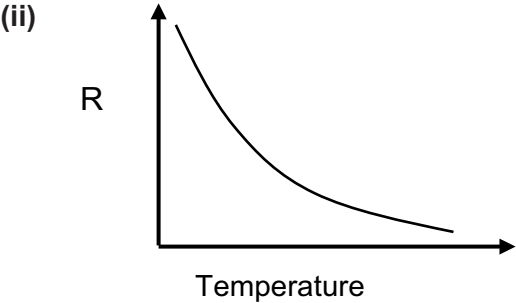

[2]

(b) (i) Sample answer  
Open-loop systems have no feedback while closed loop systems do. [1]

(ii) As the temperature increases and the resistance of the thermistor decreases, the time taken to charge the capacitor will be reduced. This will cause the threshold voltage to be reached sooner and consequently result in a shorter time period at the output. [2]

For a response not worthy of credit	[0]
Clear and coherent explanation using good English grammar.	[1]

Quality of written communication [1]



(iii)

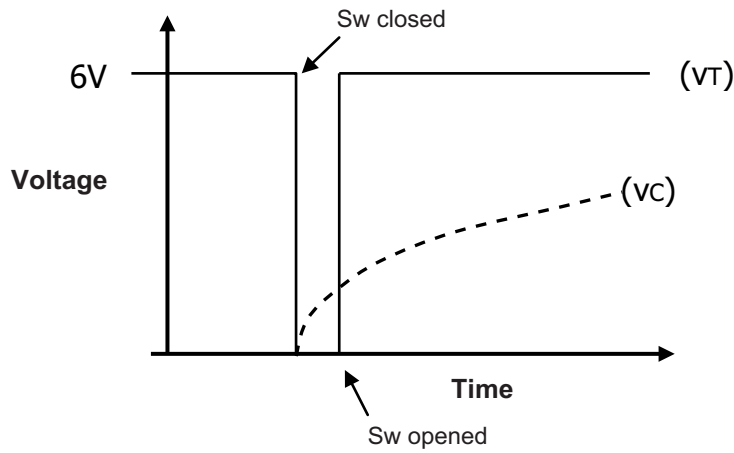

(2 marks for each correct graph)

[4]

(iv)  $T = 1.1 \times 5600 \times 0.001$   
therefore  $T = 6.16$  seconds

[2]

(c) (i)  $I_b = I_c/h_{fe} = 0.2/120 = 1.7\text{mA}$   
Voltage drop across resistor =  $6 - 0.7 = 5.3\text{V}$   
Therefore resistor value =  $5.3/0.0017 = 3118 \Omega$

[3]

(ii)

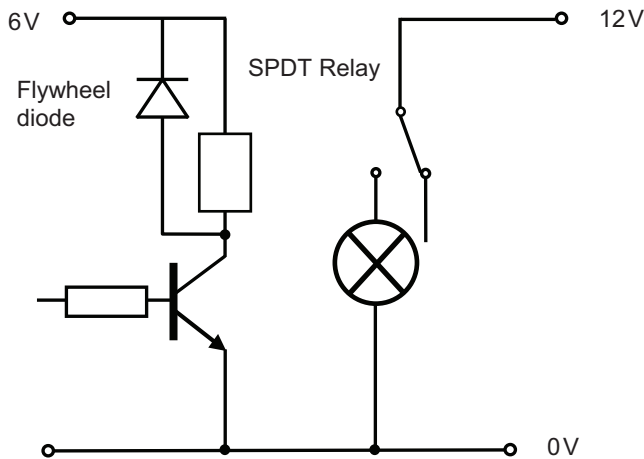

[1] for correctly connecting relay 6V supply  
[1] for correctly connecting UV unit to relay left terminal  
[1] for 12 volt supply to right terminal.  
[1] for flywheel diode placed correctly.

[4]

20

Section B

40

**Section C**

**AVAILABLE  
MARKS**

- 11 (a) (i)** A rotates in a different direction compared to F. [1]
- (ii)** Annotated sketch outlining a suitable grub screw. [1]  
Positioning of grub screw on shaft inside housing – integrating the grub screw. [1]
- (iii)** Any **two** reasons from:  
No slippage when motion is being transmitted between shafts. Precise positional control can be relied upon and ability to transmit considerable torque between shafts. Long lasting when suitably lubricated. [2]
- Quality of written communication [1]
- |  |     |
|--|-----|
| For a response not worthy of credit                        | [0] |
| Clear and coherent explanation using good English grammar. | [1] |
- (iv)** A–B  $100/50 = 2$  [1]  
C–D  $50/100 = 0.5$   
E–F  $90/60 = 1.5$  [1]
- Tot VR =  $2 \times 0.5 \times 1.5 = 1.5$  [1]
- (v)** D–C  $100/50 = 2$   
B–H  $100/100 = 1$   
Tot VR  $2 \times 1 = 2$  [1]  
OS = IS/VR  
 $130 = 260/2$   
Worm shaft rotates at 130 rev/min [1]
- (vi)** A–H  $100/50 = 2$   
Wormwheel = 80 [1]
- OS = IS/VR  
 $5 = 3200/VR$   
Therefore VR = 640 [1]
- $2 \times 80 \times 4 = 640$  [1]
- J–K VR of 4 required  
K = 176 teeth [1]

- (b) A suitable answer could involve the use of two gears with a chain and sprocket system.  
Block X could be raised or lowered on a small platform attached to the chain.

Marks awarded as follows:

Level of response not worthy of credit	[0]
Poor sketch with little or no annotation. Little information on how the design raises/lowers the block. Lack of clarity on the method used to convert the rotary motion of Shaft W to drive the raising and lowering system.	[1]
Annotated sketch is limited. The design is generally suitable showing some information on how the design raises/lowers the block. There is a limited explanation outlining the method used to convert the rotary motion of Shaft W to drive the raising and lowering system.	[2]–[3]
Detailed annotated sketch. The design is suitable showing clearly how the block raises/lowers. The explanation clearly outlines the method used to convert the rotary motion of Shaft W to drive the raising and lowering system.	[4]–[5]

[5]

20

- 12 (a) (i)** The activation method at A is a push button. [1]
- (ii)** The activation method at D is a lever. [1]
- (iii)** Method used to produce the following:
- or** connection between A, B, C & D [1]
  - Solenoid activation method including switch and power supply. [1]
  - Grouping of **or** connections [1]
  - Connection to 5PV [1]
  - See sample solution
  - or** other suitable solution
- (iv)** Method used to produce the following:
- Air bleeds [2]
  - Integration of air bleeds. [1]
  - Positioning at outstroke/Combined activation [1]
  - Connection to 5PV [1]
  - See sample solution
  - or** other suitable solution
- (v)** Flow control valve positioned on outstroke exhaust to enable cylinder **H** to outstroke slowly. [2]
- See sample solution
  - or** other suitable solution

- (b) Single and double acting cylinder outstroke force is determined by the air pressure and the size of piston area available for the air pressure to act against. The single acting cylinder instroke force is determined by the force exerted by the internal return spring. The double acting cylinder instroke force is determined by the piston area for the air pressure to act against minus the area occupied by the piston rod. [3]

For a response not worthy of credit	[0]
Little information on what determines the outstroke and instroke forces in single and double acting cylinders.	[1]
Detailed information on what determines the outstroke and instroke forces in single and double acting cylinders.	[2]–[3]
For a response not worthy of credit	[0]
Clear and coherent explanation using good English grammar.	[1]

Quality of written communication [1]

- (c) Please assume  $\pi = 3.14$ .

$$F = P \times A$$

$$8 \text{ mm diameter} = 4 \text{ mm radius}$$

$$4 \times 4 = 16$$

$$16 \times 3.14 = 50.24 \text{ mm}^2$$

[1]

$$50.24 + 420 = 470.24 \text{ mm}^2$$

$$470.24/3.14 = 149.76$$

[1]

$$\sqrt{149.76} = 12.24 \text{ mm}$$

$$12.24 \text{ mm} \times 2 = 24.48 \text{ mm}$$

[1]

20

**Section C**

**40**

AVAILABLE  
MARKS

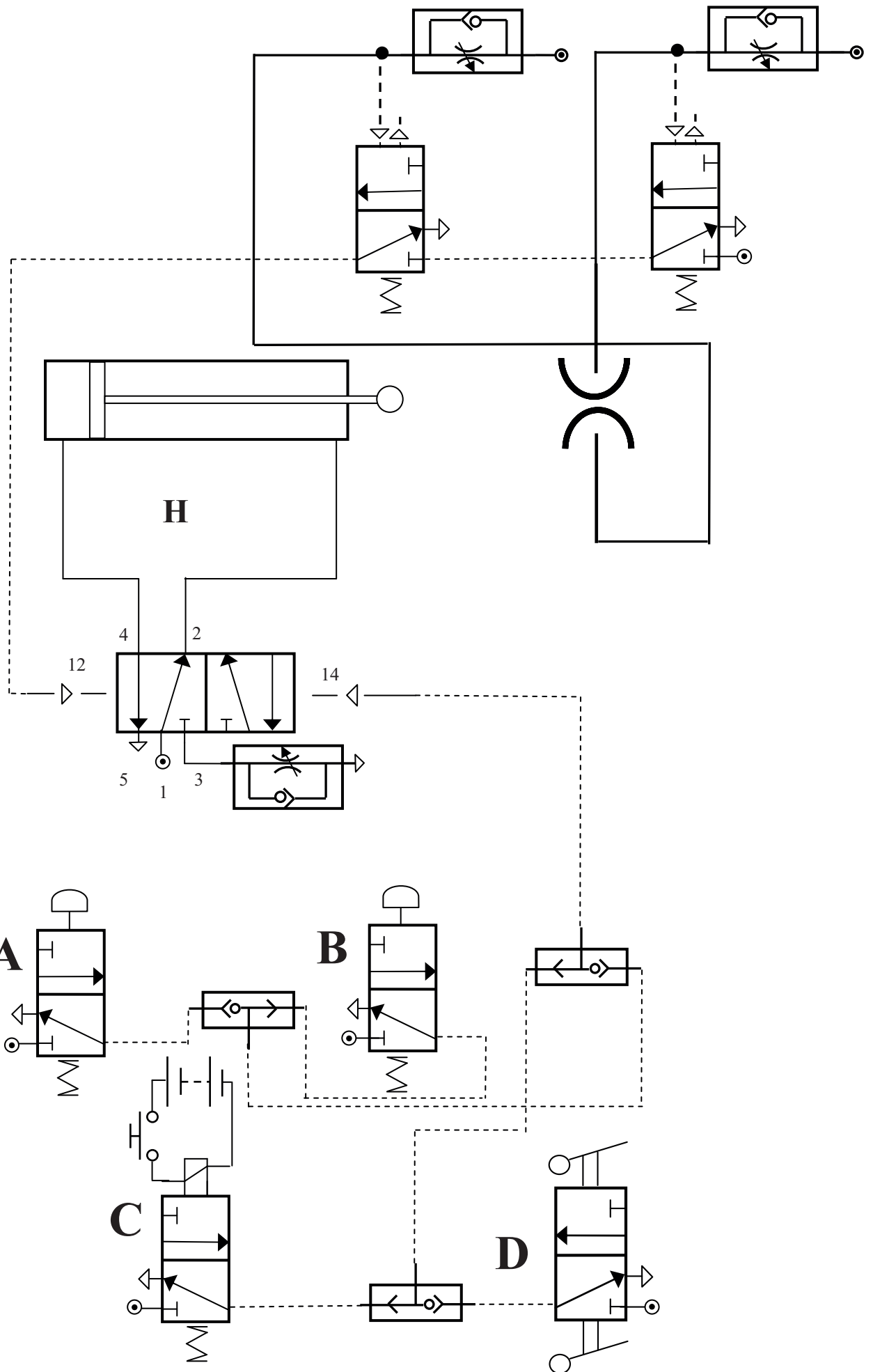

Answer No. 12 (a)(iii), (iv) and (v)

**Section D**

**AVAILABLE  
MARKS**

- 13 (a) (i)** One way in which the designer has taken into consideration the safety of the user, for example:
- The harness allows the cyclist to strap the child in place preventing them from moving forward and getting their fingers caught.
  - The foot straps allow the cyclist to strap the child’s feet in place thus preventing the child getting their foot caught in the wheel. [1]

- (ii)** Any **two** specific ways in which the designer has incorporated aesthetic appeal for example:
- Use of contrasting colours red and grey.
  - Use of soft edge curved profile.
  - Product displays good symmetry. [2]

Quality of written communication [1]

For a response not worthy of credit	[0]
Clear and coherent explanation using good English grammar.	[1]

- (iii)** Any **two** main criteria that would influence the selection of the material, for example:
- The properties required from the product (e.g. good impact resistance and toughness).
  - The range of outdoor environments that the product would be subjected to.
  - The selected scale of production. [2]

- (iv)** Any **two** main criteria that would influence the selection of the manufacturing process, for example:
- It is a cost-effective method which will facilitate manufacturing in large numbers
  - Can be manufactured as a one piece shell to reduce assembly costs
  - Requires the minimum amount of finishing techniques in order to make it suitable for use by the consumer. [2]

- (b)** Any **two** main characteristics associated with reflective films for example:
- Available in a range of colours.
  - Relative low cost.
  - Suitable for outdoor conditions. [2]

- (c) (i)** Any **one** main characteristic associated with corrugated board, for example:
- Good strength to weight ratio.
  - Can be recycled. [1]

- (ii)** Any **one** main characteristic associated with bio-degradable plastic, for example:
- Appropriate strength making it suitable for packaging.
  - Low environmental impact. [1]

- (d) (i) Pictogram based on a child's profile positioned in the seat. The representation of weight of between 9 and 22 kg could be presented as a dial and a form is needed to indicate that this is acceptable. [4]

Level of response not worthy of credit	[0]
A vague sketch. Difficulty in determining if the design is appropriate and conveys the stated information.	[1]
The sketch is limited. The design conveys aspects of the stated information.	[2] or [3]
Detailed and appropriate sketch. The design clearly conveys all aspects of the stated information.	[4]

- (ii) Straps could be riveted to the back of the seat and adjustable side release plastic buckles could be used to secure the cover. [4]

Level of response not worthy of credit	[0]
A vague sketch lacking detail and appropriate annotation. Difficulty in disseminating if the design is appropriate.	[1]
The design is appropriate but the sketch and annotation are limited.	[2] or [3]
Detailed annotated sketch representing an appropriate design.	[4]

20

- 14 (a) A design specification is a list that tells the designer exactly what the product has to do and what the design requirements are whereas a manufacturing specification lists the information a manufacturer needs in order to produce the product. [2]

- (b) (i) Any **two** main characteristics associated with lateral thinking, for example:
- Lateral thinking is solving problems through an indirect and creative approach.
  - Lateral thinking is the removal of dominant ideas and the search for different ways of looking at things.
  - Lateral thinking is a relaxation of the rigid logical control associated with vertical thinking, and the use of chance. [2]

- (ii) Any **two** main characteristics associated with a registered design, for example:
- Registered designs give you the right to stop anyone copying or using your design in the UK for up to 25 years
  - A registered design will cover the lines, contours, colours, shape, texture and materials of the product.
  - Registered designs must be renewed every 5 years for up to 25 years. [2]

(c) **Three** main characteristics associated with the COSHH regulations, for example:

- Outline guidance on the safe handling, use and storage of hazardous substances in the workplace.
- Series of regulations that every business/company must follow to protect workers, customers and the general public from the effects of hazardous substances.
- COSHH set out eight basic measurements that should be taken into account to assess and control exposure of hazardous substances. [3]

Quality of written communication [1]

For a response not worthy of credit	[0]
Clear and coherent explanation using good English grammar.	[1]

(d) Any **two** main characteristics associated with a Gantt chart, for example:

- A Gantt chart is a chart that shows a project schedule.
- Gantt charts illustrate the start and finish dates/timings of the elements of a project.
- Some Gantt charts also show the dependency or relationships between activities. [2]

(e) (i) A solution could be based on a coarse threaded section on the scoop end mating with a threaded hole on the shaft or handle.

Level of response not worthy of credit	[0]
A vague sketch lacking detail and appropriate annotation. Difficulty in determining if the design is appropriate.	[1]
The design is appropriate but the sketch and annotation are limited.	[2] or [3]
Detailed annotated sketch representing an appropriate design.	[4]

[4]

(ii) A solution could be based on an ergonomically profiled covering manufactured from rubber to facilitate it to be pressed onto the body, and capable of being produced in a range of colours and designs.

Level of response not worthy of credit	[0]
A vague sketch lacking detail and appropriate annotation. Difficulty in determining if the design is appropriate.	[1]
The design is appropriate but the sketch and annotation are limited.	[2] or [3]
Detailed annotated sketch representing an appropriate design.	[4]

[4]

**Section D**

**Total**

**AVAILABLE  
MARKS**

20

**40**

**80**