



Rewarding Learning

ADVANCED
General Certificate of Education
2013

Technology and Design

Assessment Unit A2 1

assessing

Systems and Control

and

Product Design

[AV211]



TUESDAY 14 MAY, MORNING

TIME

2 hours.

INSTRUCTIONS TO CANDIDATES

Write your Centre Number and Candidate Number on the Answer Booklet provided and on the A3 pro forma answer pages provided.

Answer **two** questions from Section A **or** Section B **or** Section C.

Answers to question **1(d)**, question **2(d)(iii)**, questions **4(c)** and **(d)**, question **5(f)** and question **6(f)** should be made on the A3 pro forma answer pages provided.

At the conclusion of the examination, attach the A3 pro forma answer pages securely to the Answer Booklet with the treasury tag supplied.

INFORMATION FOR CANDIDATES

The total mark for this paper is 80, including a maximum of 4 marks for quality of written communication.

Marks for quality of written communication will be awarded for questions **1(e)**, **3(c)(ii)** and **6(e)**.

Figures in brackets printed down the right-hand side of pages indicate the marks awarded to each question or part question.



Section A

Electronic/Microelectronic Systems

Answer **either** the two questions in Section A or the **two** questions in Section B or Section C.

- 1 (a) A microswitch is to be used to provide an input to an electronic system. The microswitch is operated by pressing the actuator button. The microswitch and its corresponding circuit symbol are shown in **Fig. 1(a)**.

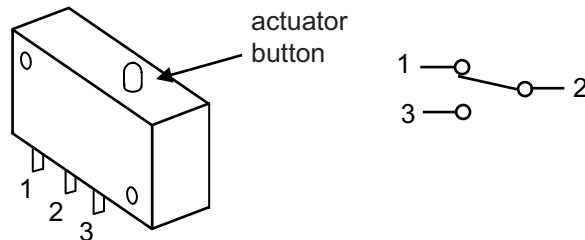

Fig. 1(a)

- (i) State how the contact between terminal 1 and 2 is held in the normally closed position. [1]
- (ii) Show with the aid of a circuit diagram how the microswitch shown in **Fig. 1(a)** could be used in conjunction with any other components to provide a 5 volt logic “1” input to an electronic system when the actuator button is pressed. [2]
- (iii) During tests it was found that the microswitch contacts tended to “bounce” when activated, causing unwanted input signals. Draw an annotated diagram of a circuit which could be used to overcome this problem. [5]
- (b) A conveyor system on a container packaging line is shown in **Fig. 1(b)**. As the containers pass a microswitch they are counted in batches of either 2 or 4 depending on customer requirements. A stepper motor is to be used to control the speed and position of the conveyor.

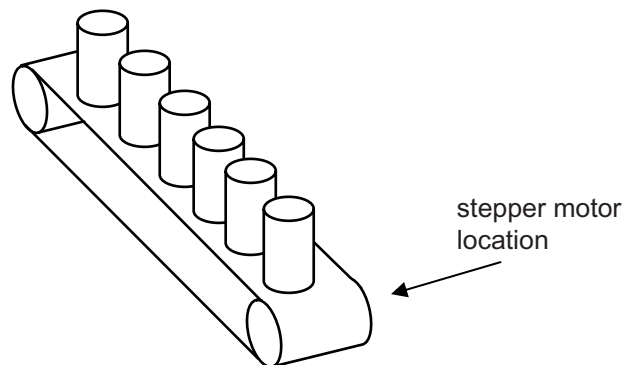

Fig. 1(b)

Draw an annotated circuit diagram showing how the speed and position of a stepper motor can be controlled using a stepper motor driver integrated circuit. [4]

(c) Fig. 1(c) shows part of a counter circuit that has been designed to count the number of containers into batches as they pass from the conveyor.

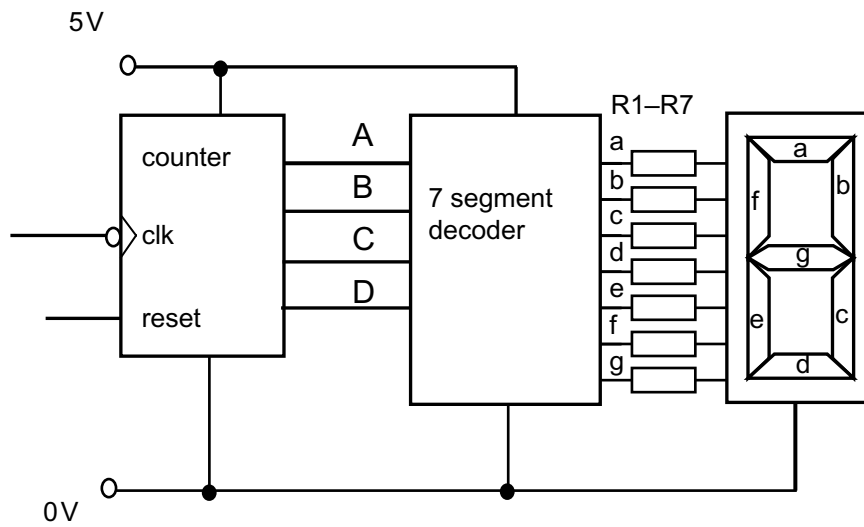

Fig. 1(c)

- (i) State the function of the resistors labelled R1–R7 in Fig. 1(c). [1]
- (ii) Briefly explain the purpose of the 7 segment decoder in the circuit shown in Fig. 1(c). [2]
- (iii) Draw a truth table for the 7 segment decoder shown in Fig. 1(c) for the inputs A, B, C, and D with the corresponding outputs a to g for the displayed numbers 2 and 4 only where A is the least significant bit. [4]
- (iv) Describe an alternative method of decoding the 7 segment display in the circuit shown in Fig. 1(c). [2]
- (d) The circuit shown in Fig. 1(c) is to form the basis of a system to stop the stepper motor driven conveyor in Fig. 1(b) when the batch number has been reached. Using electronic circuit diagrams on the blank pro forma provided (answer number 1(d)) show how the following could be achieved.
- Allow the operator to select batch counts of either 2 or 4.
 - Count and display up to 2 or 4.
 - Produce a logic “0” to stop the stepper motor after each batch has been completed.
 - Allow the operator to reset the system (using a switch) to cause the conveyor to move again.
- [10]
- (e) An electronic systems designer may have to choose between using a stepper motor and a DC motor for a particular application. Outline in detail **three** main differences between these 2 types of motors. Discuss the main criteria that will influence the choice of motor for a particular application, providing a specific example to supplement your discussion. [5]
- Quality of written communication [4]

2 **Fig. 2(a)** shows part of a proposed system which consists of 3 tanks that supply powdered chemicals to a mixing unit. The levels in the tanks are indicated on coloured lamps which can be checked by an operator. The levels in the tanks are detected by 3 sensors S1, S2, and S3 as shown in **Fig. 2(a)**. Each sensor outputs logic “0” when the powder levels are satisfactory and a logic “1” when low. A green coloured lamp will be illuminated if all tanks are sufficiently full. If any one tank has a low level an amber lamp will illuminate and if any 2 or all 3 tanks have low levels a red lamp will be illuminated.

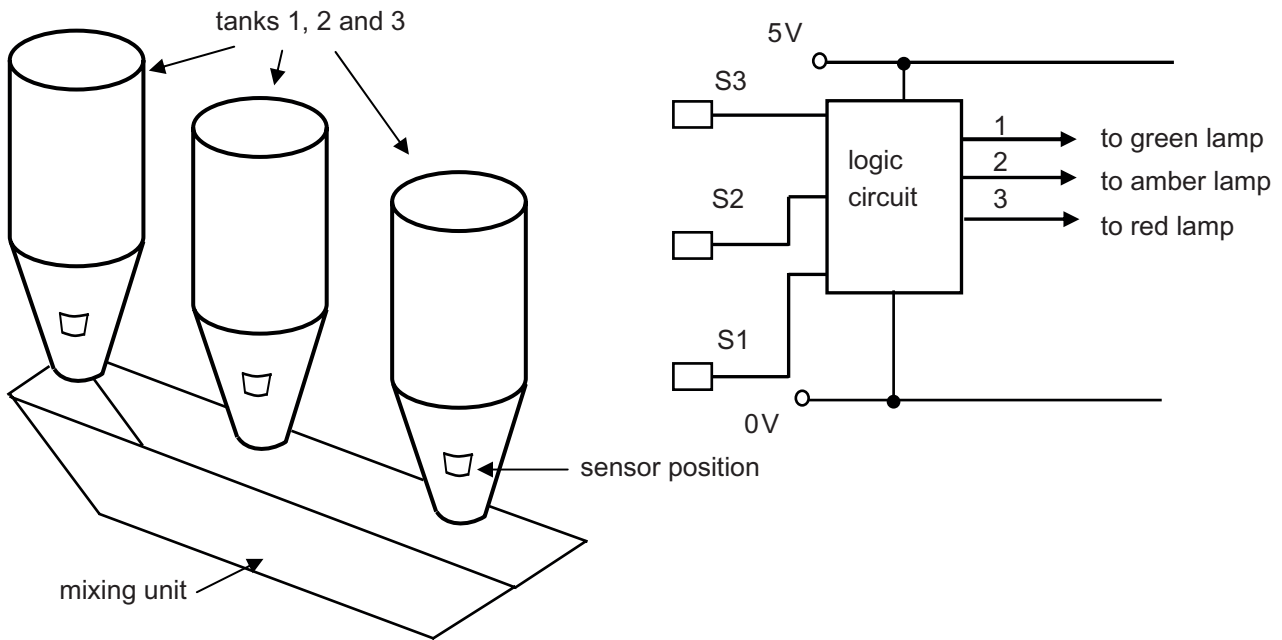

Fig. 2(a)

- (a) (i) The sensors to be used to detect the levels in the tanks in **Fig. 2(a)** should not come into direct contact with the powder. Describe, with the aid of a diagram a suitable sensor that could be used for this purpose. [2]
- (ii) Draw a truth table showing the logic signals from the sensors and the corresponding outputs 1, 2 and 3 for the logic circuit shown in **Fig. 2(a)**. [4]
- (iii) Using Karnaugh Maps where appropriate, deduce minimised logic expressions for the outputs 1, 2 and 3. [3]
- (iv) Draw logic circuits for the minimised logic expressions for outputs 1, 2 and 3. [3]

(b) The system shown in **Fig. 2(a)** is to be modified to incorporate a more sophisticated method of determining the quantity of powder in the tanks by using strain gauge sensors. A separate strain gauge R_g , attached to the bottom of each of the 3 tanks is to be connected in a circuit arrangement shown in **Fig. 2(b)**.

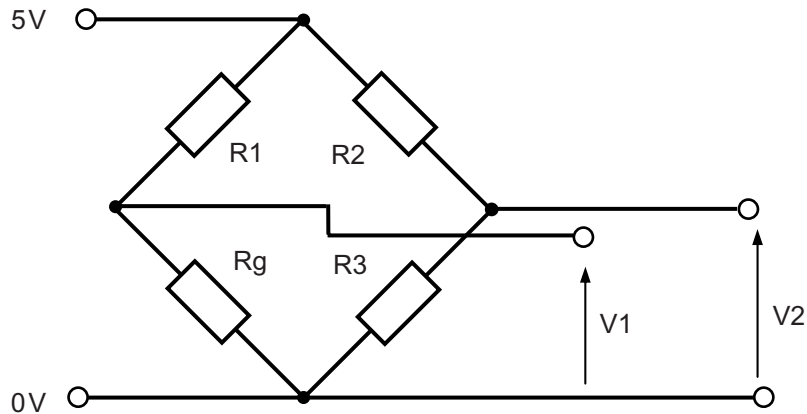

Fig. 2(b)

- (i) State the name of the circuit arrangement shown in **Fig. 2(b)**. [1]
- (ii) With the aid of an annotated sketch, explain the principle of operation of a strain gauge. [3]
- (iii) The strain gauge resistance R_g is 120.0Ω when not strained. Calculate the voltages V_1 and V_2 for the circuit arrangement shown in **Fig. 2(b)** when the resistance of the gauge is increased by 2% due to strain where R_1, R_2 and $R_3 = 120\Omega$. [3]
- (c) The outputs from the circuit arrangement shown in **Fig. 2(b)** are to be connected to a difference amplifier with an output voltage V_o that will range from 0V to 4V as the strain gauge resistance is increased by 2% (where $V_o = (R_f/R_1)(V_1 - V_2)$).
- (i) Draw a difference amplifier based on an op amp showing how the circuit shown in **Fig. 2(b)** would be connected to it. [2]
- (ii) Determine the gain of the difference amplifier to provide the required output. [2]
- (iii) Choose suitable values for R_f and R_1 where the resistor values should be at least $10k\Omega$. [2]

- (d) As a further development the output from the difference amplifier in **2(c)** is to be displayed on an 8 segment common cathode LED bar array as shown in **Fig. 2(d)**. A PIC with an analogue input and built in analogue to digital converter (ADC) is to be utilised to drive the LED bar array. There will be one bar array for each of the tanks shown in **Fig. 2(a)** and the digital range of the PIC is 0–255.

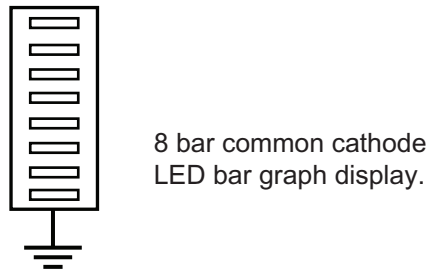

Fig. 2(d)

- (i) When developing the electronic system described in **2(d)** above, safety must be considered. State **three** main safety issues that should be considered when using electronic and microelectronic systems. [3]
- (ii) Explain with the aid of a circuit diagram how common cathode LEDs are connected. [2]
- (iii) Using electronic circuit diagrams on the blank pro forma provided (answer number **2(d)(iii)**), design a PIC based circuit and associated flow chart program (for one display only) that will fulfil the following:
- Light each bar of the LED array for input voltage levels up to a maximum of 4 volts, each bar corresponding to a 0.5 V increment.
 - When the input voltage is less than 0.5 V the bottom bar in the LED should flash on and off once per second. At the same time a buzzer should sound to alert the operator that the tank is almost empty. [10]

Section B

Mechanical and Pneumatic Control Systems

Answer **either** the two questions in Section B or the **two** questions in Section A or Section C.

- 3 (a) **Fig. 3(a)** shows a prototype design for a ride on lawnmower. The lawnmower contains a range of mechanical systems including a gearbox, pulleys and bearings.

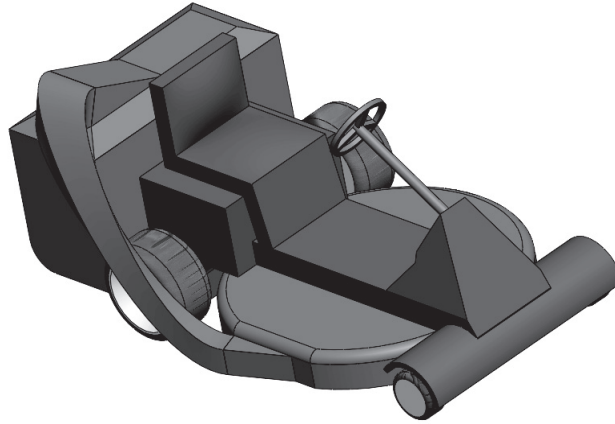

Fig. 3(a)

- (i) The gearbox of the lawnmower contains a range of gears. Using an annotated sketch briefly explain what is meant by the following terms associated with gears:
- Metric module. [1]
 - Pitch circle diameter. [1]
- (ii) The drive shaft and cutting blade in the lawnmower are linked by chain and sprocket. Outline **one** advantage and **one** disadvantage of using this system. [2]
- (iii) Using an annotated sketch, name and draw in your answer booklet an appropriate clutch which could transmit motion from shaft **Z** to shaft **X** (**Fig. 3(a)(iii)** below) to enable a speed of approximately 1600 rev/min to be reached. [4]

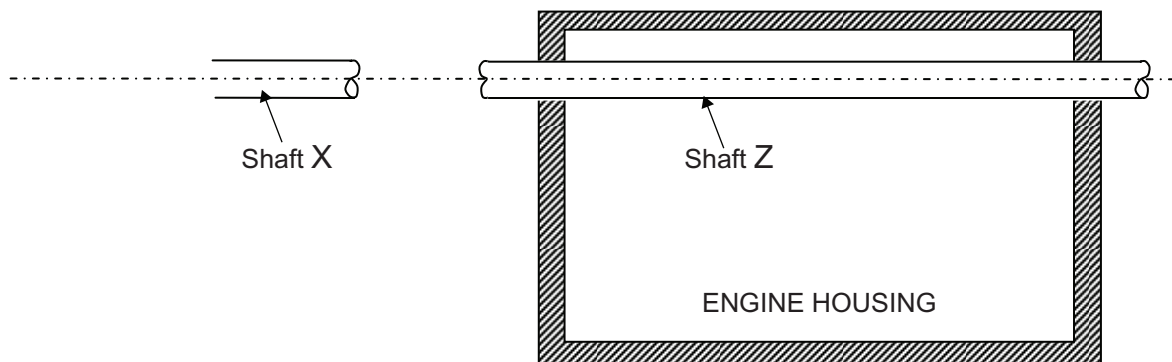

Fig. 3(a)(iii)

(b) Fig. 3(b) below shows a compound gear train to be used for initial testing in the gearbox.

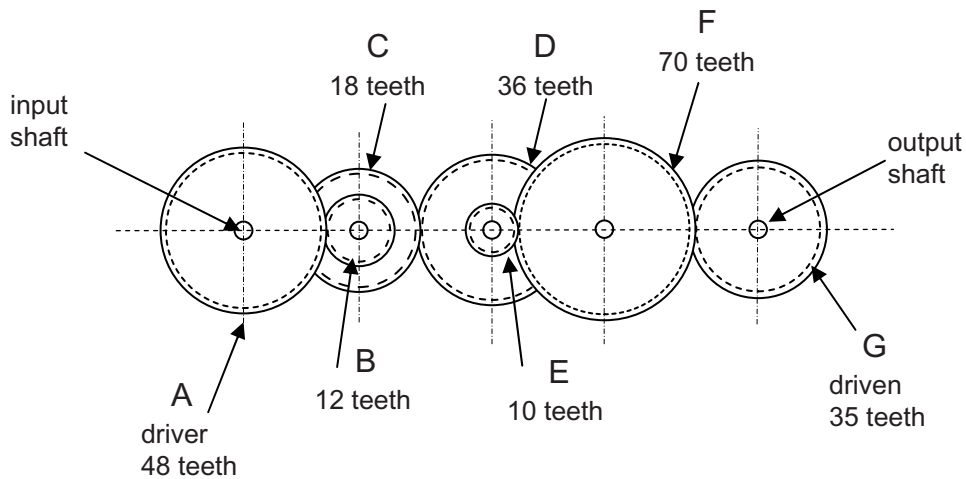

Fig. 3(b)

- (i) Calculate the velocity ratio from gear A to gear G. [2]
- (ii) Calculate the output torque for the compound gear train shown in Fig. 3(b) if the input torque is 210 Nm. [3]
- (iii) Using the value for output torque from (b)(ii) and assuming no power loss due to friction, calculate the power from the output shaft if it rotates at 215 rev/min (rpm). [3]

(c) In any mechanical system it is essential that all aspects of the engine are suitably sealed.

- (i) With the use of an annotated sketch in your answer booklet describe and fully justify a suitable seal between the engine housing and the rotating shaft as shown in Fig. 3(c)(i). [5]

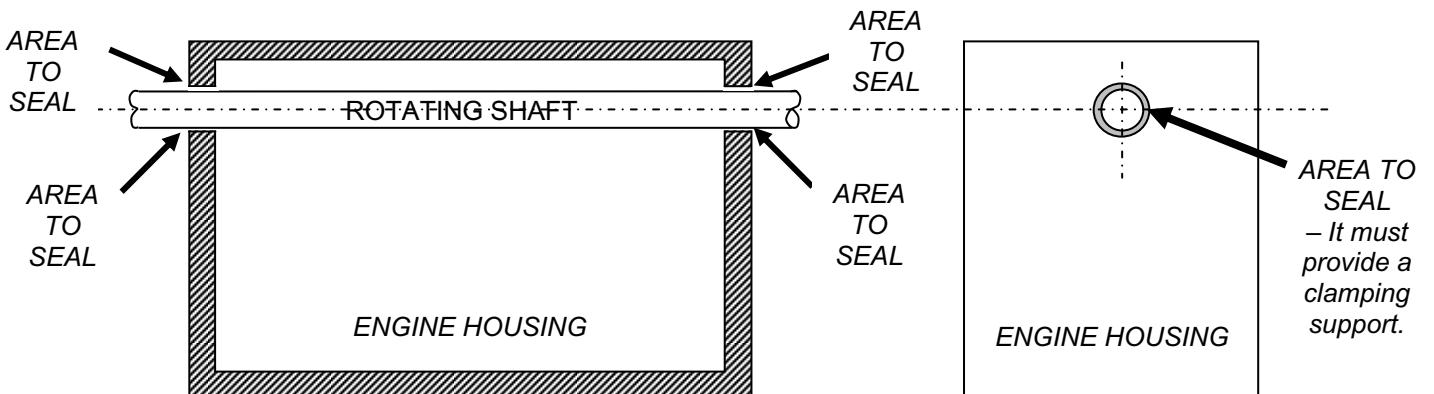

Fig. 3(c)(i)

- (ii) The wheel assembly of the lawnmower shown in **Fig. 3(c)(ii)** uses a bearing to support the motion of the axle. Given that there are radial and axial loads imposed on the axle outline **one** advantage and **one** disadvantage when using each of the following bearings; plain bearing and self-aligning bearing. Also, select a suitable bearing for the lawnmower.

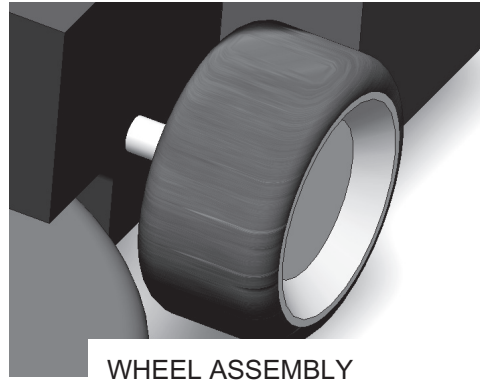

Fig. 3(c)(ii)

Quality of written communication

[5]

[4]

- (d) A number of modifications have been suggested for the lawnmower. In your answer booklet design, draw and annotate a mechanical system that would achieve each of the following requirements:

- (i) A mechanism by which the top of the lawnmower box could be locked down to seal the grass as shown in **Fig. 3(d)(i)**. This mechanism must be **quick release**. [5]

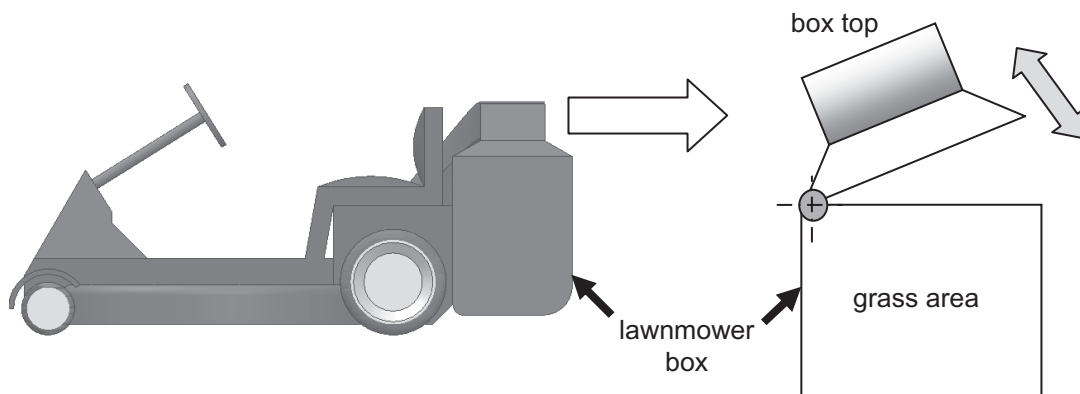

Fig. 3(d)(i)

- (ii) The operator uses a trailer to transport the lawnmower. The straps in **Fig. 3(d)(ii)**, after being attached need tensioned in order to secure the lawnmower on the trailer during transit. Outline a means of allowing the operator to increase or decrease the tension on the straps at **A** in order to secure the lawnmower firmly on the trailer. [5]

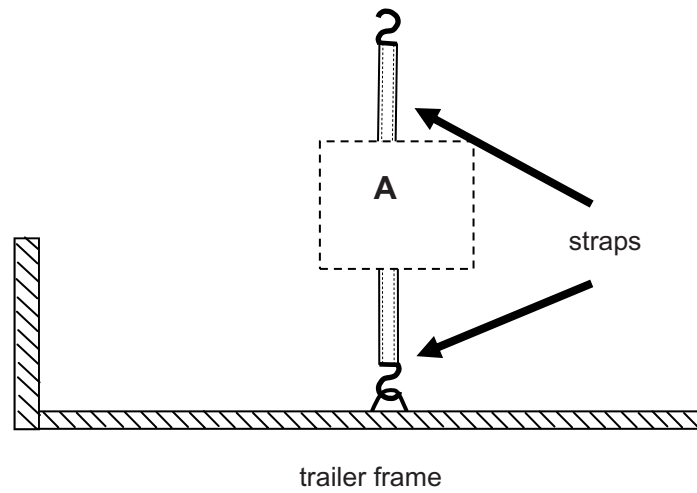

Fig. 3(d)(ii)

- 4 (a) (i) Outline the difference between an open and closed loop system. [1]
- (ii) State the main advantage of having feedback in a closed loop system. [2]
- (b) (i) Explain how the circuit in **Fig. 4(b)** operates starting from when valve A is activated (your answer should include a detailed explanation of the operation of valve C). [4]

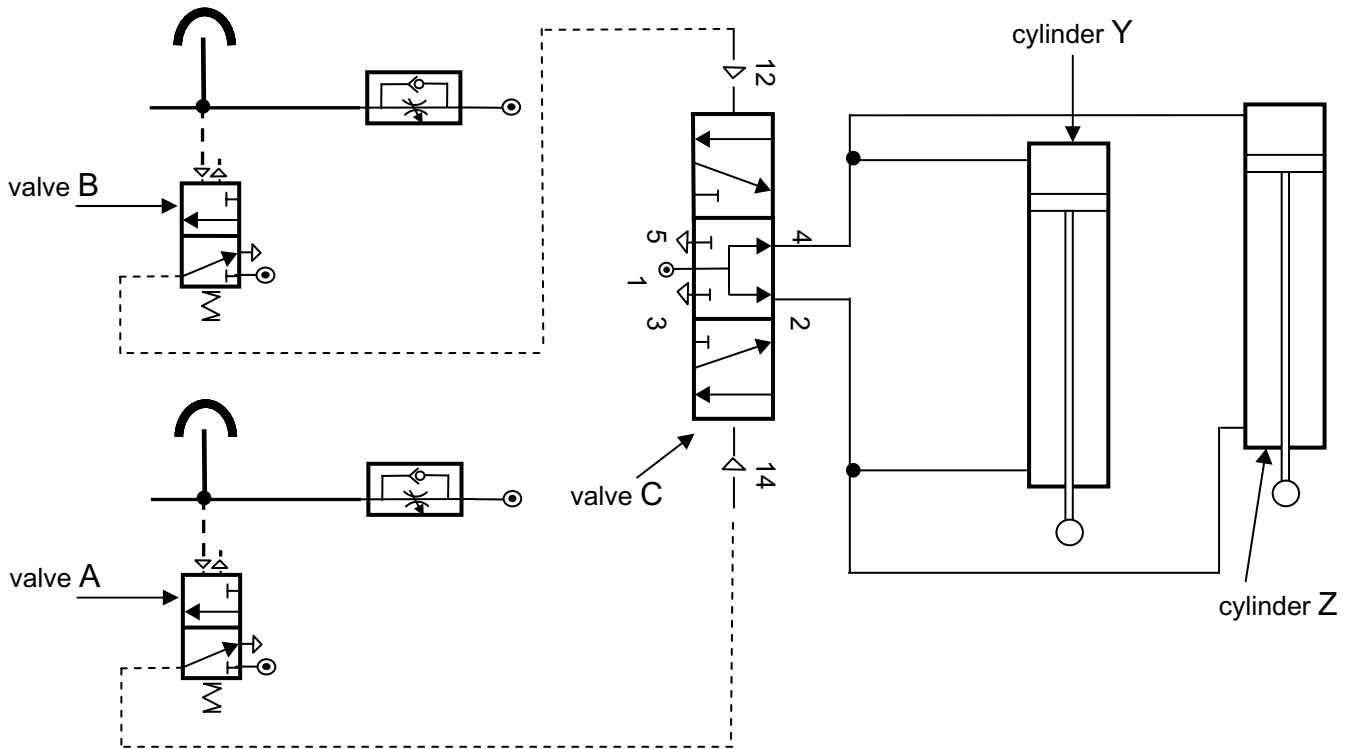

Fig. 4(b)

- (ii) Calculate the work done by the cylinder Y if the force required to outstroke is 1098.3 N and the distance moved by the force is 400 mm. [2]
- (iii) The double acting cylinders Y and Z operate with an air pressure of 0.3 N/mm^2 with each producing a force of 1098.3 N during the outstroke. It is intended to replace Y and Z with one large double acting cylinder. Calculate the piston radius of this replacement double acting cylinder which will operate at the same air pressure and produce the same overall force. Assume $\pi = 3.14$. [3]

(c) On the pro forma provided (answer number **4(c)**) draw a suitable sequential pneumatic circuit to achieve the desired sequence outlined below. This pro forma shows a pneumatic based system used in a log cutting factory and is operated from the control panel using the following sequence:

- A log is positioned on the rollers and the guard lowered to the closed position.
- On the control panel the operator must press two valves at the same time to start the sequence. This sequence cannot begin unless the guard is closed.
- Cylinders A1 and A2 go positive to clamp the log in place.
- Cylinder B goes positive, and remains out for a set time in order to release the acid to assist with removing the bark and then goes negative.
- Cylinder C goes positive with the motorised saw cutting the log to the desired length.
- Cylinders A1 and A2 go negative and allow the log to be unclamped.
- Cylinder C goes negative to retract the motorised saw.
- Cylinder D goes positive pushing the log off the rollers and down the chute.
- When the log has dropped into the chute it momentarily covers the air bleed to enable cylinder D to go negative. [18]

(d) On the pro forma provided (answer number **4(d)**) design, draw and annotate a pneumatic system which will:

- (i)** Return Cylinder C to the negative position if the guard is accidentally lifted or the emergency button is pressed at any stage during the operation. Cylinder C must also be able to accommodate any existing signal lines. [5]
- (ii)** Send a momentary signal (single air pulse) to the counter using a proximity sensor each time a log leaves the chute. [5]

BLANK PAGE
(Questions continue overleaf)

Section C

Product Design

Answer **either** the two questions in Section C or the **two** questions in Section A or Section B.

- 5 **Fig. 5(a)** shows an outline drawing of a car seat suitable for children of age range 3–8 years.



© Thinkstock

Fig. 5(a)

- (a) Briefly explain how and why new products arise. [2]
- (b) Introduction, growth, maturity and decline are stages in the life cycle of products such as the car seat shown in **Fig. 5(a)**. With reference to the car seat briefly explain **two** main characteristics associated with each of the following:
- Introduction.
 - Growth.
 - Maturity. [6]
- (c) For the company designing and manufacturing the car seat in **Fig. 5(a)** researching the market environment provides valuable information about demographic trends, lifestyle changes and government legislation.
- (i) Briefly explain the type of information that would be gained by researching each of the following and suggest how this would inform the future decisions of the company:
- Demographic trends.
 - Lifestyle changes.
 - Government legislation. [6]

(ii) In order to expand their business potential the car seat company has developed a marketing strategy which is to involve market penetration, product development and diversification.

With reference to the car seat manufacturer, briefly explain what is meant by the following terms and how they could help expand the business potential of the company:

- Market penetration.
- Product development.
- Diversification.

[6]

(d) Information and Communication Technology (ICT) is widely used to assist companies with Quality Control (QC) and Quality Assurance (QA) systems.

(i) For a specific product of your choice describe how ICT is used to assist in the implementation of Quality Control systems.

[2]

(ii) For a specific product of your choice describe how ICT is used to assist in the implementation of Quality Assurance systems.

[2]

(e) With the use of environmentally friendly manufacturing processes and with the introduction of new technology product designers can help influence some of our environmental concerns and issues.

(i) Select a specific manufacturing process of your choice and explain how this process has become more environmentally friendly.

[2]

(ii) Select **two** different examples of the use of new technology and briefly explain how each of these have influenced environmental issues.

[4]

(f) With reference to **Fig. 5(f)** below using the blank A3 pro forma provided (answer number **5(f)**) produce:

(i) Sketches of a suitable graphic design for a single sided leaflet to communicate to the user how the harness needs to be fitted using the following steps (leaflet size is indicated on the pro forma).

1. Release the harness by pressing the centre of the buckle.
2. Slip the retainer strap over the child's head.
3. Place the straps over the child's shoulders.
4. Bring the buckle up between the legs and insert the two brackets on the straps into the buckle to secure the child in the harness. [5]

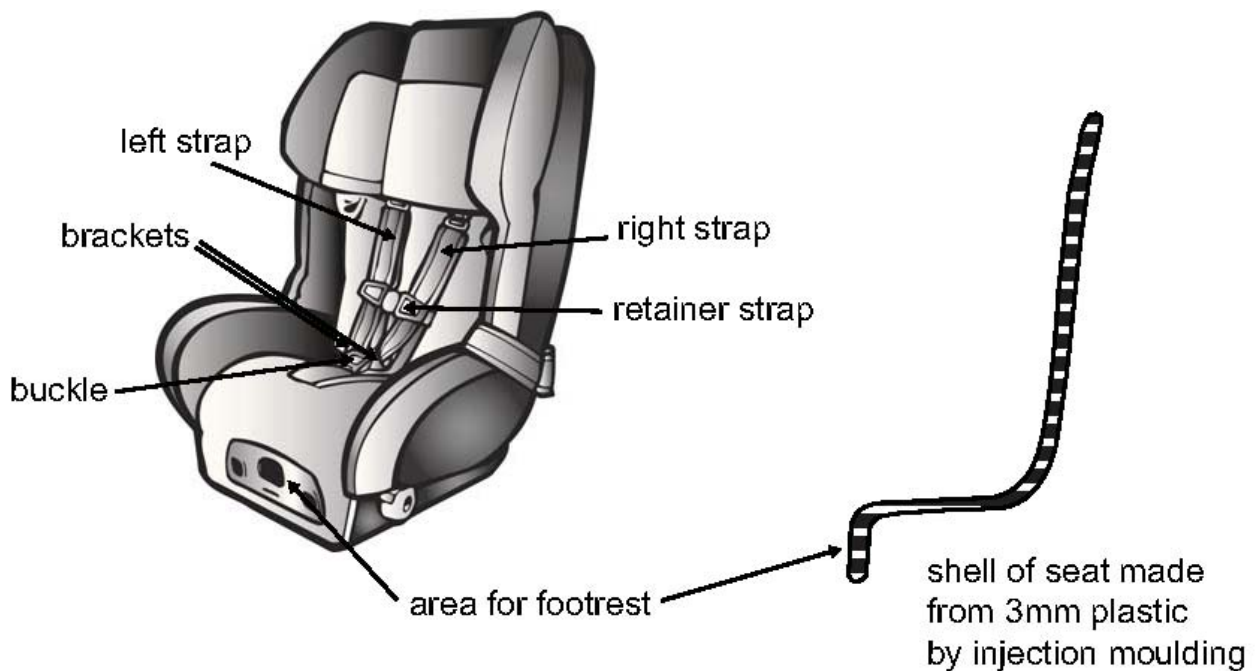

© Thinkstock
Fig. 5(f)

(ii) Annotated sketches of a design of a footrest located as shown in **Fig. 5(f)**. Your sketch should show any changes to be made to the profile of the chair and how the footrest could be manufactured and secured to the shell of the seat. [5]

6 Fig. 6(a) below shows a photograph of a wheelie bin used for domestic waste.

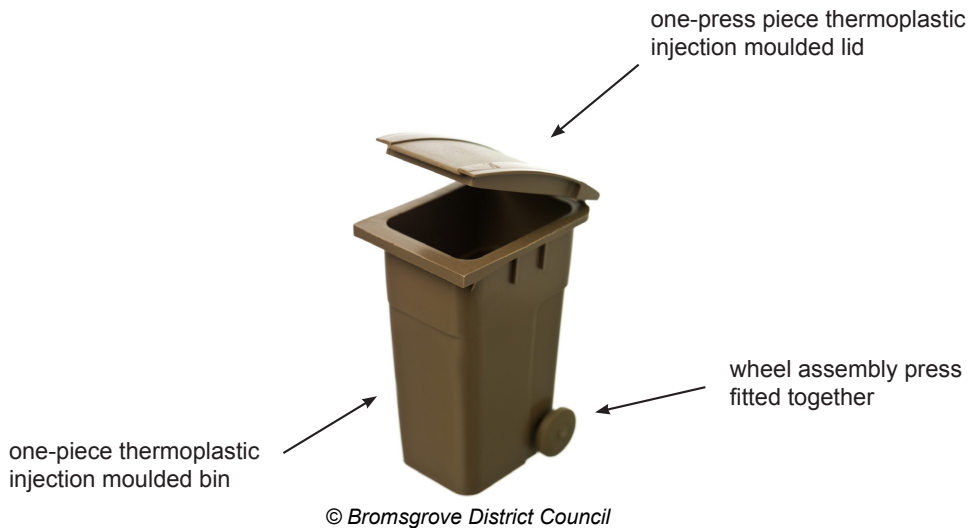

Fig. 6(a)

- (a) For any **two** of the 6R's explain how the company could claim that through the design and manufacture of the wheelie bin shown in Fig. 6(a) environmental issues are being addressed. [4]
- (b) The company manufacturing the wheelie bins is considering the use of geothermal and solar as alternative energy sources in order to drive down long-term energy costs and utilise more sustainable sources.
- (i) Briefly explain the basic principles of geothermal as a renewable energy source. [2]
- (ii) Briefly explain the basic principles of solar power as a renewable energy source. [2]
- (c) The company is considering researching the market to gain opinion from the client base on the feasibility of offering a graphic design service. This service is intending to design the exterior appearance of the wheelie bin to individual personal preferences.
- (i) Telephone interviews are to be used as a means of collecting information. Briefly outline **two** advantages and **one** disadvantage associated with the use of telephone interviews as a means of collecting information. [3]
- (ii) In planning for this service the company would need to be aware of the demands of the consumer.
- Briefly explain the main characteristics associated with each of the following types of consumers:
- Fashion innovators.
 - Masses.
 - Laggards.
- [6]

(d) If this service is to operate and personalised wheelie bins are to be produced, then a pricing strategy needs to be considered.

Briefly explain how the pricing strategy for each of the stages of the life cycle of the product (introduction, growth, maturity and decline) may be determined. [4]

(e) Describe and fully justify the impact that the Memphis movement has had on product design. [5]
Quality of written communication [4]

(f) (i) Fig. 6(f)(i) shows the wheelie bin with the lid partially open.

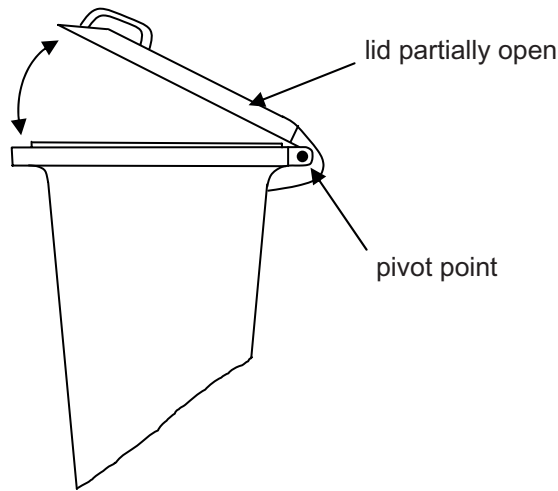

Fig. 6(f)(i)

On the blank A3 pro forma provided (answer number 6(f)) produce **one** suitable solution for the following:

Annotated sketches of a design which can be quickly engaged or released by the operator to ensure that the lid of the bin is securely closed. This will ensure that the wind will not blow the lid open and remove some of the waste from the bin. [5]

- (ii) **Fig. 6(f)(ii)** shows a part drawing of the profile of the main body of the wheelie bin. Periodically the inside of the bin is cleaned by using a power washer to create a high pressure jet of water to help remove the dirt which builds up in the inside.

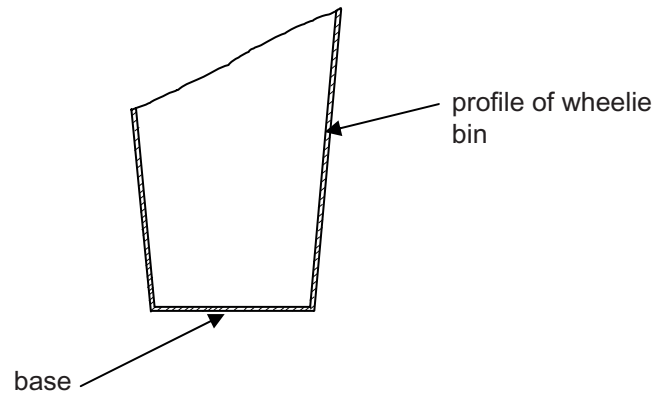

Fig. 6(f)(ii)

On the blank A3 pro forma provided (answer number **6(f)**) produce **one** suitable solution for the following:

Annotated sketches of a design which will aid the internal cleaning of the bin by addressing the following:

1. Change the internal profile of the bin to assist the removal of the dirty water from the base.
2. Provide a means of draining the dirty water out of the base (your design must be easily removed in order to release the dirty water and easily replaced and secured after cleaning).

[5]

THIS IS THE END OF THE QUESTION PAPER

Permission to reproduce all copyright material has been applied for.
In some cases, efforts to contact copyright holders may have been unsuccessful and CCEA
will be happy to rectify any omissions of acknowledgement in future if notified.

Question No. 1(d)

ADVANCED LEVEL TECHNOLOGY AND DESIGN
Assessment Unit A2 1
2013

Centre Number

71	
----	--

Candidate Number

--

Pro forma answer page
(answer number 1(d))

Question No. 2(d)(iii)

ADVANCED LEVEL TECHNOLOGY AND DESIGN
Assessment Unit A2 1
2013

Centre Number

71	
----	--

Candidate Number

--

Pro forma answer page
(answer number 2(d)(iii))

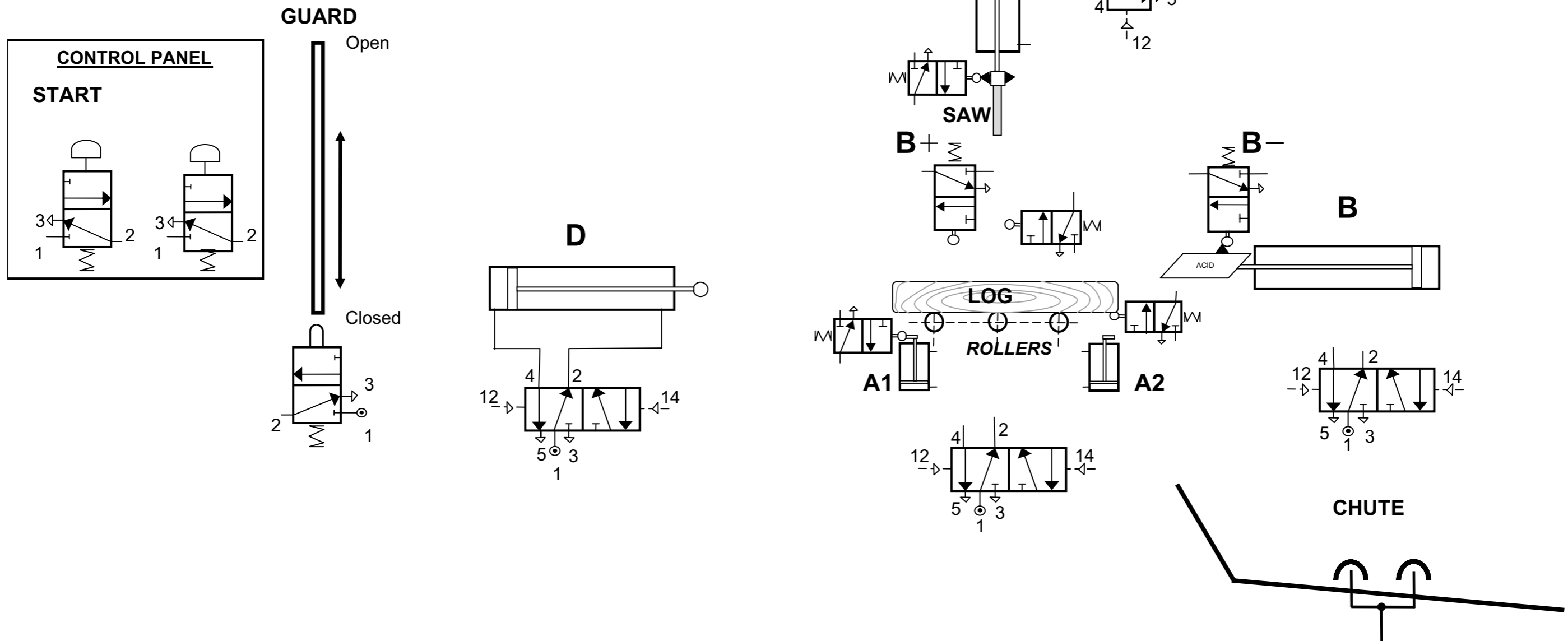

Pro forma answer page
 (answer number 4(c))

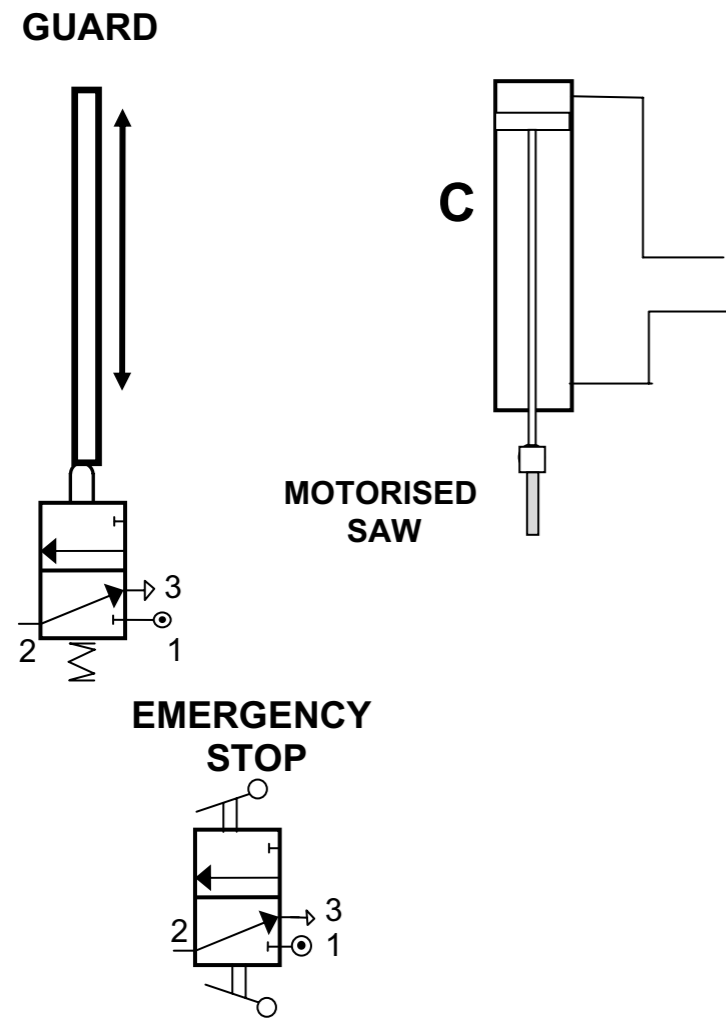

Momentary air signal
 send to activate counter

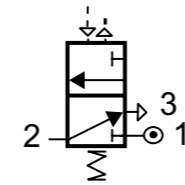
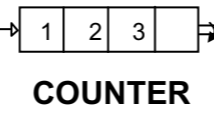

CHUTE

LOCATION OF
 PROXIMITY SENSOR

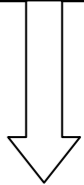

Pro forma answer page
 (answer number 4(d))

71	
----	--

--



**Pro forma answer page
(answer number 5(f))**

Question No. 6(f)

ADVANCED LEVEL TECHNOLOGY AND DESIGN
Assessment Unit A2 1
2013

Centre Number

71

Candidate Number

Pro forma answer page
(answer number 6(f))