



Rewarding Learning

ADVANCED
General Certificate of Education
2013

Technology and Design

Assessment Unit A2 1

assessing

Product Design and Systems and Control

[AV211]

TUESDAY 14 MAY, MORNING

**MARK
SCHEME**

General Marking Instructions

These mark schemes are intended to ensure that the AS/A2 examinations are marked consistently and fairly. The mark schemes provide examiners with an indication of the nature and range of candidate responses likely to be worthy of credit. They also set out the criteria which they should apply in allocating marks to candidates' responses. The mark schemes should be read in conjunction with these general marking instructions which apply to all papers.

Quality of candidates' responses

In marking the examination papers, examiners will be looking for a quality of response reflecting the level of maturity which may reasonably be expected of 17- and 18-year-olds which is the age at which the majority of candidates sit their AS/A2 examinations.

Flexibility in marking

The mark schemes which accompany the specimen examination papers are not intended to be totally prescriptive. For many questions, there may be a number of equally legitimate responses and different methods by which the candidates may achieve good marks. No mark scheme can cover all the answers which candidates may produce. In the event of unanticipated answers, examiners are expected to use their professional judgement to assess the validity of answers. If an answer is particularly problematic, then examiners should seek the guidance of the Supervising Examiner for the paper concerned.

Positive marking

Examiners are encouraged to be positive in their marking, giving appropriate credit for valid responses rather than penalising candidates for errors or omissions. Examiners should make use of the whole of the available mark range for any particular question and be prepared to award full marks for a response which is as good as might reasonably be expected for 17- and 18-year-old candidates. Conversely, marks should only be awarded for valid responses and not given for an attempt which is completely incorrect and inappropriate.

Types of mark schemes

Mark schemes for questions which required candidates to respond in extended written form are marked on the basis of levels of response which take account of the quality of written communication. These questions are indicated on the cover of the examination paper.

Quality of written communication

Quality of written communication is taken into account in assessing candidates' responses to all questions that require them to respond in extended written form.

In all cases, correct alternative responses will be given full credit.

AVAILABLE MARKS

Section A

1 (a) (i) By means of a spring or spring mechanism. [1]

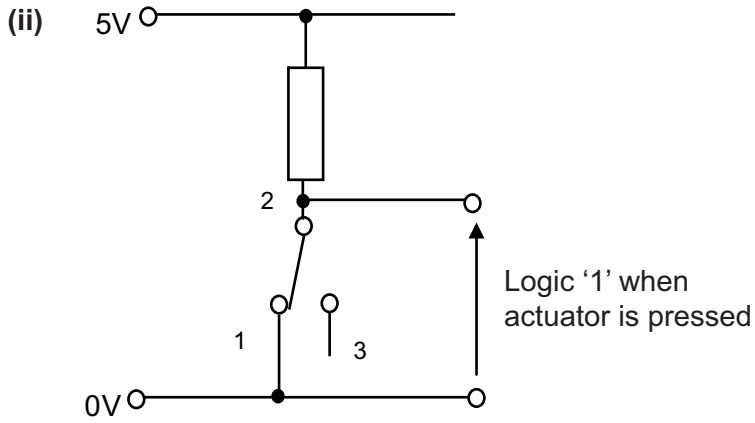

[2]

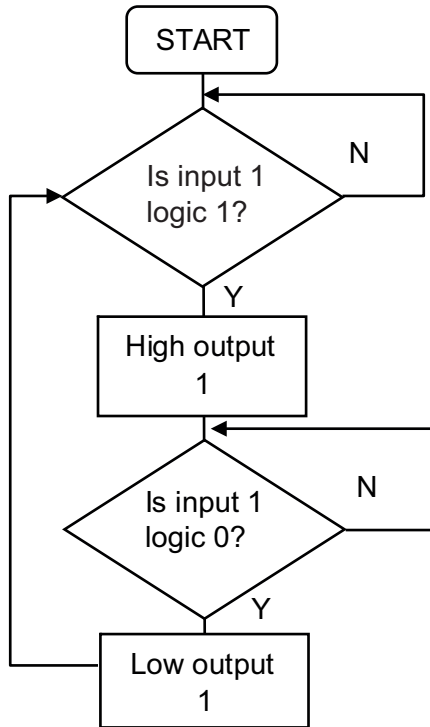
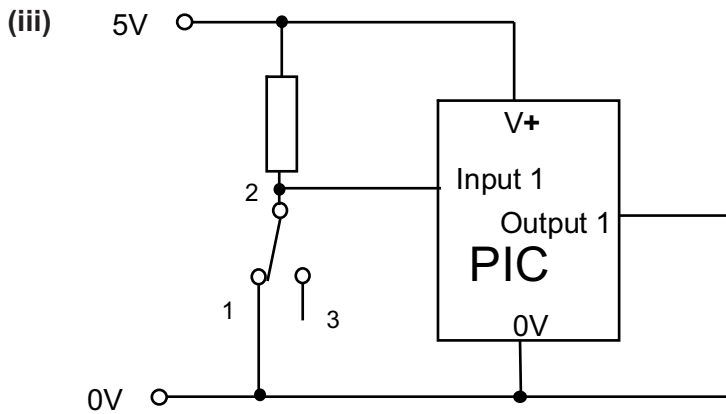

[5]

(b)

A 'high' voltage will cause the motor to rotate clockwise

The frequency of the step pulses will determine the speed of the motor

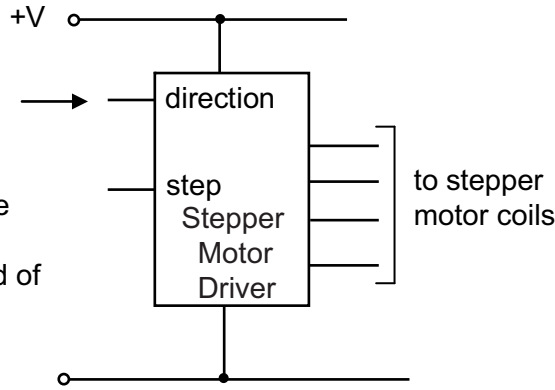

[4]

(c) (i) Current limiting resistors to protect the segments in the display. [1]

(ii) To produce a decimal digit by switching on the appropriate segments that correspond with the binary inputs from the binary counter. [2]

(iii)

A	B	C	D	a	b	c	d	e	f	g
0	1	0	0	1	1	0	1	1	0	1
0	0	1	0	0	1	1	0	0	1	1

[4]

(iv) A microcontroller (PIC) could be programmed to 'read' the output from the logic circuit and turn on the appropriate outputs on the 7 segment display. [2]

(d) Possible answer

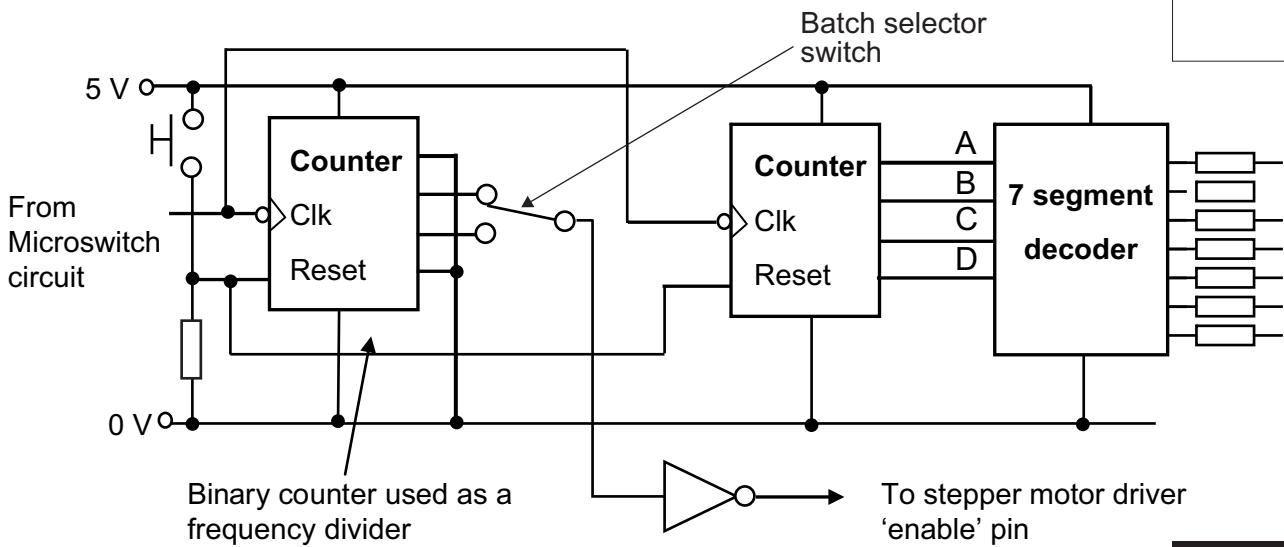

[10]

AVAILABLE MARKS

AVAILABLE MARKS

- (e) Main differences – answers likely to refer to any **three** of the following:
- Positional accuracy – stepper motors provide positional accuracy. DC motors without position transducers do not have such accuracy.
 - Torque/RPM – stepper motors provide good torque at lower RPM. DC motors have good torque characteristics at higher RPM.
 - Ability to stop quickly – Stepper motors do not overshoot under normal operating conditions.
 - Efficiency – Stepper motors require a holding current to maintain position which can be inefficient. DC motors with an appropriate gearbox do not require a holding current.
 - Cost consideration – basic DC motors are relatively cost effective solution compared to stepper motors.

Factors to consider: any **one** from the following:

1. torque and RPM requirements
2. space considerations
3. positional requirements
4. cost/efficiency

Examples – a robot arm for assembly line will require positional accuracy with high torque and speed requirements therefore a stepper motor would be chosen.

Motorised valve – opening and closing a valve will require forward and reverse only with high torque obtained through use of a gearbox therefore a DC motor would be chosen. [5]

Quality of written communication [4]

40

Level of response not worthy of credit.	[0]
Poor selection and use of a writing form and style appropriate to the content. The content is poorly organised and little use is made of appropriate Technological vocabulary. The writing is barely legible and the spelling, grammar and punctuation is inaccurate.	[1]–[2]
Good selection and use of a writing form and style appropriate to the content. The content is organised and use is made of appropriate Technological vocabulary. The writing is legible and the spelling, grammar and punctuation is accurate.	[3]
Very good selection and use of a writing form and style appropriate to the content. The content is well organised and good use is made of appropriate Technological vocabulary. The writing is clearly legible and the spelling, grammar and punctuation is very accurate.	[4]

2 (a) (i) Circuit diagram showing suitable non contact sensor such as an infrared transmitter and phototransistor.

[2]

AVAILABLE MARKS

(ii)

S1	S2	S3	3	2	1
0	0	0	0	0	1
1	0	0	0	1	0
0	1	0	0	1	0
1	1	0	1	0	0
0	0	1	0	1	0
1	0	1	1	0	0
0	1	1	1	0	0
1	1	1	1	0	0

[4]

(iii)

Green light = $S1'S2'S3'$

S1 S2	00	01	11	10
S3				
0	0	0	1	0
1	0	1	1	1

Red light = $S2S3 + S1S3 + S1S2$

S1 S2	00	01	11	10
S3				
0	0	1	0	1
1	1	0	0	0

Amber light = $S1'S2'S3 + S1'S2S3' + S1S2'S3'$

[3]

(iv)

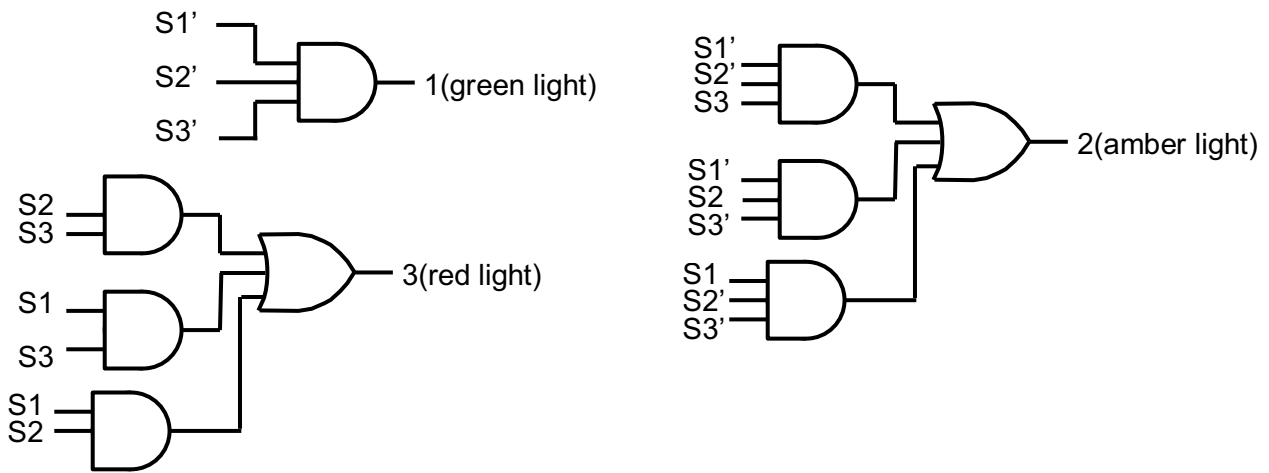

[3]

(b) (i) Wheatstone bridge.

[1]

(ii) Annotated sketch showing foil pattern with explanation that resistance changes when the gauge is deflected.

[3]

(iii) $V_1 = 2.53 \text{ V}$ [2]
 $V_2 = 2.5 \text{ V}$ [1]

[3]

(c) (i)

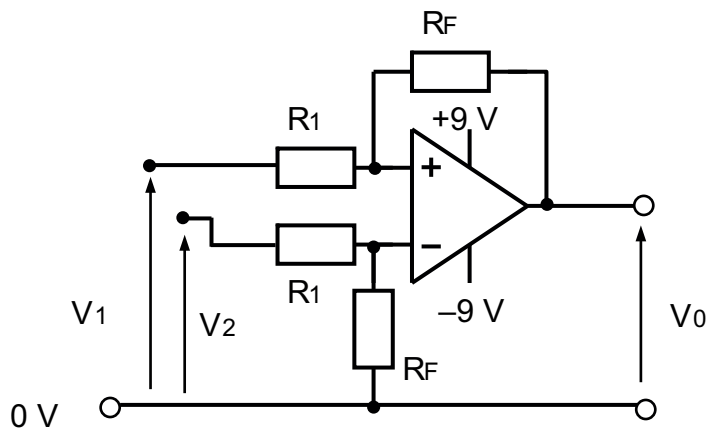

[2]

(ii) $4 = (R_f/R_1)(2.53-2.5)$ therefore gain = 133

[2]

(iii) $R_f = 1.33 \text{ M}\Omega$ $R_1 = 10 \text{ k}\Omega$

[2]

(d) (i) 1. Correct component rating to prevent overheating/burn hazard.
 2. Correct insulation to prevent electric shock or short circuit.
 3. Fire hazard caused by overheating circuits or exposed contacts. [3]

(ii) Diagram showing common cathode connections, with explanation [2]

AVAILABLE MARKS

(iii) Sample answer.

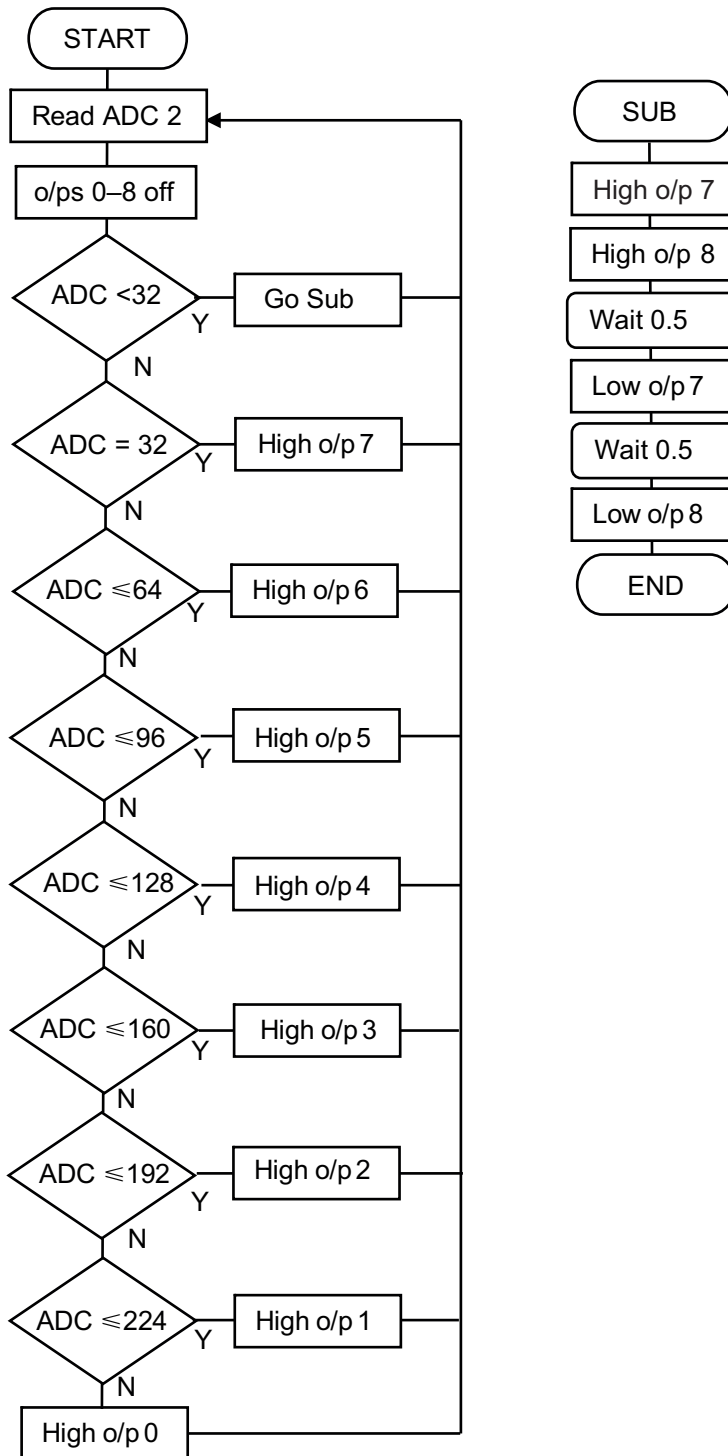
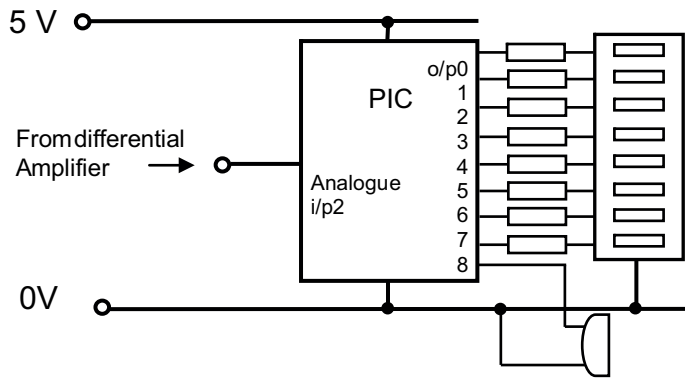

AVAILABLE MARKS

[10]

40

Section A

40

Section B

Mechanical

**AVAILABLE
MARKS**

- 3 (a) (i)** Metric module – is the pitch circle diameter in mm divided by the number of teeth. [1]
 Pitch circle diameter – the effective circle that passes through the contact point of meshing gears. [1]
- (ii)** Advantages [1]:
 Any **one** from:
 No slippage
 Is very strong
 Distance between sprockets can be large
- Disadvantages [1]:
 Any **one** from:
 Chain can stretch
 Tension must be constant
 Expensive to manufacture [2]
- (iii)** Centrifugal clutch [1]
 Outer drum and shaft [1]
 Inner linings and shaft [1]
 Spring [1] [4]
- (b) (i)** $VR = \frac{\text{Driven}}{\text{Driver}}$
- $$\frac{12}{48} \times \frac{36}{18} \times \frac{70}{10} \times \frac{35}{70}$$
- $$\frac{1}{4} \times \frac{2}{1} \times \frac{7}{1} \times \frac{1}{2}$$
- $$\frac{14}{8} = 1:1.75$$
- [2]
- (ii)** output torque = input torque $\times \frac{\text{Product of driven teeth}}{\text{Product of driver teeth}}$
- output torque = $210 \times (12 \times 36 \times 70 \times 35 / 48 \times 18 \times 10 \times 70)$
 output torque = $210 \times 1058400 / 604800$
 output torque = 367.5 Nm [3]
- (iii)** $P = T\omega$
 $P = T = 367.5 \times \omega = 2 \pi / 60 \times 215 \text{ rpm}$
 $P = 367.5 \times 22.50$
 $P = 8268.75 \text{ W}$
 $P = 8.27 \text{ kW}$ [3]

(c) (i) **Garter Seal**
Annotated Sketch [2]

Description

A garter spring is a helical extension spring with its ends connected so that each spring becomes a circle and exerts radial forces. [2]

Justification

They are often used to maintain the function of radial shaft seals by keeping the elastomer seals tight against the rotating shaft. [1] [5]

(ii) **Plain Bearing**

Advantage (One from the following)

- This type of bearing is extremely effective when used for a range of speeds and loads.
- Cheap to manufacture – Nylon is often used for plain bearings because of self-lubricating properties. Other suitable materials are brass, cast iron and aluminium if the bearing is suitably lubricated.

Disadvantage (One from the following)

- Act as a very basic bearing
- Prone to wear

Self-Aligning Bearing

Advantage (One from the following)

- Self-aligning bearings allow the shaft to run at a slight angle to the housing axis.
- Can be used where precise alignment cannot be maintained.

Disadvantage (One from the following)

- The axis of the inner ring, balls and cage can deflect to some extent around the bearing centre.
- Often quite expensive given the range of mechanisms.

Select a suitable bearing – Self-Aligning [5]

For a response not worthy of credit.	[0]
Poor selection and use of a writing form and style appropriate to the content. The content is poorly organised and little use is made of appropriate technological vocabulary. The writing is barely legible and the spelling, grammar and punctuation is inaccurate.	[1]–[2]
Good selection and use of a writing form and style appropriate to the content. The content is organised and use is made of appropriate technological vocabulary. The writing is legible and the spelling, grammar and punctuation is accurate.	[3]
Very good selection and use of a writing form and style appropriate to the content. The content is well organised and good use is made of appropriate technological vocabulary. The writing is clearly legible and the spelling, grammar and punctuation is very accurate.	[4]

Quality of written communication [4]

- (d) (i) Toggle clamps – sketch and annotation showing key features of the application. [5]
- (ii) Ratchet and pawl – sketch and annotation showing key features of the application. [5]
- 4 (a) (i) Open loop describes a system in which the building blocks connect in a linear way, i.e. operator pressing a valve to operate a cylinder to stamp boxes, a closed loop describes a system with feedback. [1]
- (ii) Feedback is used to provide information back to the control device so that the output can be modified. [2]
- (b) (i) When the air bleed in Valve A is covered this allows air to flow to the 14 side of the 5/3 valve C. This will enable both double acting cylinders to go positive only when the air bleed is being covered. When the air bleed is released by the user the 5/3 valve will return to the centre state which is pressurised and as a result the cylinders have positional control i.e. it can hold any position between being fully outstroked or fully instroked. When the air bleed is pressed which controls valve B air is supplied to the 12 side of the 5/3 valve both double acting cylinders will start to go negative. If the user releases contact with the bleed the 5/3 valve will move to the central position and lock the cylinder at its current position. [4]
- (ii) $W = F \times L$ $1098.3\text{ N} \times 0.4 = 439.32\text{ J}$ [2]
- (iii) $F = PXA$ Total force = 2196.6 N
 $2196.6\text{ N} = 0.3 \times A$ [1]
 $7322 = A$ [1]
 $48.29\text{ mm} = \text{radius}$ [1] [3]
- (c) Guard 3/2 valve piped up correctly [1]
Control Panel piped up correctly [1]
Method of activating cylinder A1 A2+ [1]
Method of activating cylinder B+ with Time Delay then B – [3]
Method of activating cylinder C+ [1]
Method of activating A1 A2– [1]
Method of activating cylinder C– [1]
Method of activating cylinder D+ [1]
Method of connecting up air bleed [2]
Method of activating Cylinder D– [1]
Group changeover valves [5] [18]

AVAILABLE
MARKS

40

Answer No. 4(c)

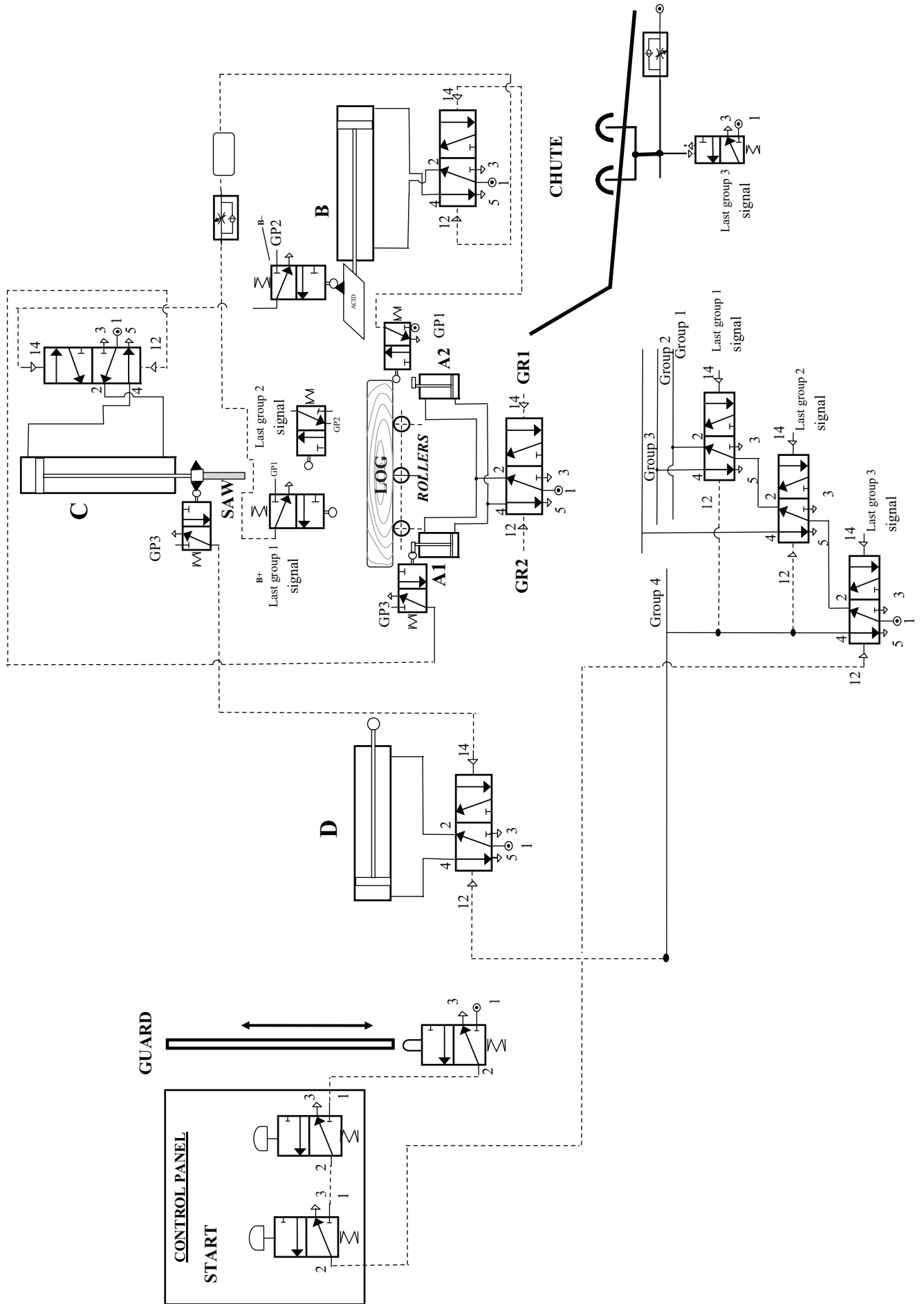

(d) (i)

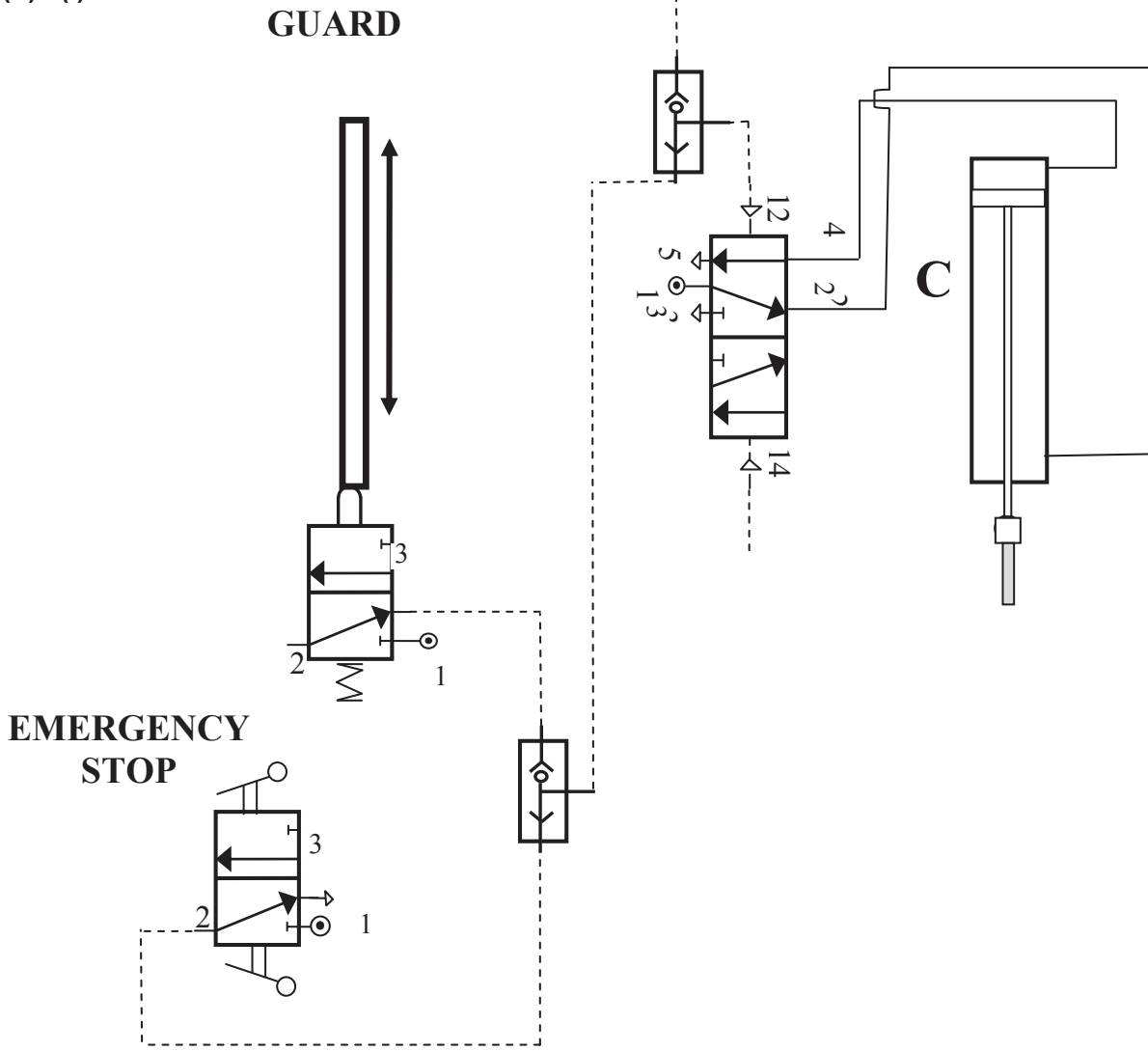

(ii)

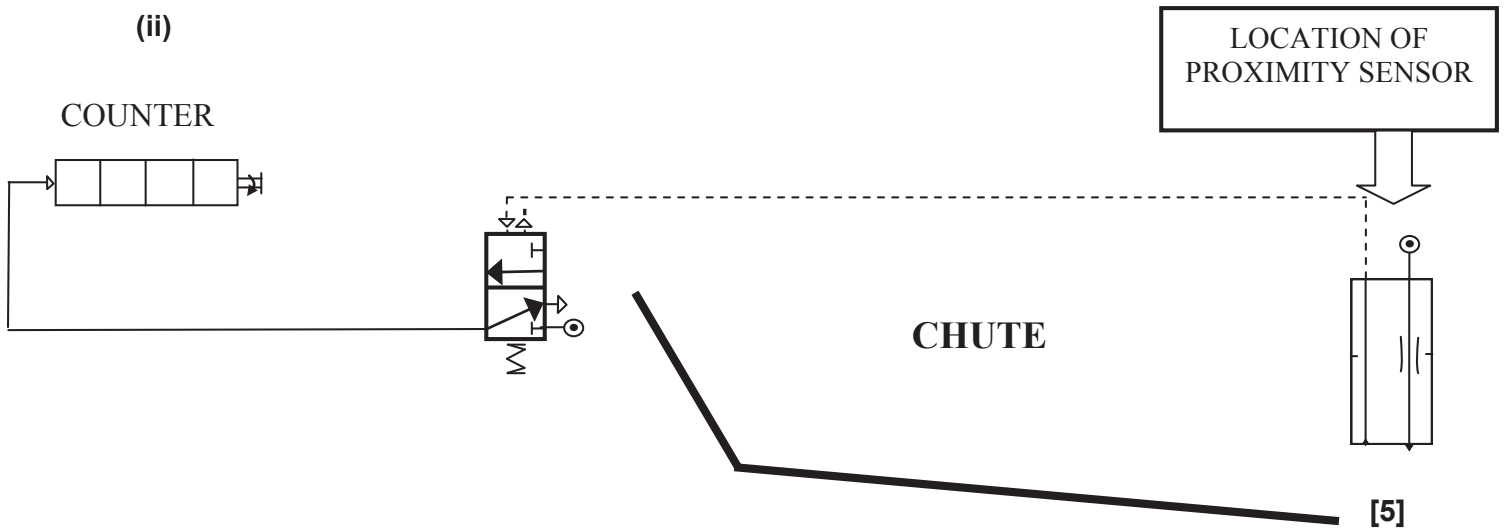

AVAILABLE MARKS
40
40

Section B

Section C

AVAILABLE
MARKS

Product Design

5 (a) New Products:

- They may arise as a result of new technology, materials or processes.
 - As a result in people’s wants, needs or possible a change in trends likes and perceived value.
 - A drive to improve the quality of people’s lives
 - Some companies develop new products due to commercial reasons. [2]
- Other answers considered.

(b) Any **two** from each heading:

Introduction

- New car seat product launch with low growth of sales figures
- Large promotional campaign to introduce product to the market
- Large initial costs to launch the campaign
- Little or no profit in this phase of the product. [2]

Other answers considered.

Growth

- The profits margins start to rise in this phase of the life cycle
- Steady growth in sales figures as market accepts product
- Change in focus regarding advertising and promotion
- Initial set cost reduced considerably. [2]

Other answers considered.

Maturity

- Sales figures reach a steady level
- Profit remains stable or declines slightly
- Company needs to spend money to invigorate the market place
- Sales/promotional strategy changes. [2]

[6]

Other answers considered.

(c) (i) Any **two** from each heading:

Demographic trends

- By researching demographic trends the company would gain information on population numbers at a specific age and projected figures for the future. This would help inform decision on production, life span of the product and possibly determine the range within the product. [2]

Other answers considered.

Lifestyle changes

- By researching lifestyle changes the company will gain information on the use of cars versus public transport information on available income (make up of the home), information on the public’s perception on safety of children in the car. The role of other agents, e.g. day care and after school agents. This will help inform the design (lower cost models) numbers and specific features for the car seat. [2]

Other answers considered.

Government Legislation

- By researching government legislation the company would gain information on what current legislation or future legislation is planned by government regarding child car seats in terms of direction (forward or rear facing), seat belt positioning, age and restrictions. Research may reveal if the legislation is compulsory and if it allows some flexibility
This will inform the future decisions in design, range of products and potential sales figures. [2] [6]
- Other answers considered.

(ii) Market penetration

- Market penetration involves increasing sales to existing customers and/or finding new customers for existing products, for example by various methods of promotion and advertising. The company could look into providing car companies with child seats for family customers as an incentive. [2]

Other answers considered.

Product development

- Product development involves creating new, modified or updated products aimed mainly at the company's existing customers. For the car seat company a new model for older children could be included a model which fits directly onto the pram and provides coverage for the outdoor environment etc. [2]

Other answers considered.

Diversification

- Diversification involves a company both in the development of new products and in selling those products to new customers. For example the company could look at expanding into other aspects of seating, e.g. for bicycles, high chairs and seating for toys etc. [2] [6]

Other answers considered.

(d) (i) Depending upon the specific choice of product.

ICT is used in Quality control, which reviews the quality of all factors involved in production. ICT can be used for data comparisons, electronic dimensioning, monitoring production, decision making and taking recovery action. [2]

Other answers considered.

(ii) Depending upon the specific choice of product.

ICT can be used to monitor, inspect, evaluate and make decisions with regard to the quality of raw materials. ICT is also widely used in assemblies (monitoring position of components), products and components, services related to production, and management, production and inspection processes. [2]

Other answers considered.

(e) (i) Powder metallurgy:

Powder metallurgy is a manufacturing process where various powder metals such as stainless steel, brass, copper, iron and bronze are compressed and then sintered (heated) to increase adhesion between particles.

The part is formed by compressing the powder metal, or blended metal powders, in accurately formed dies and punches in special types of hydraulic presses. The compressed pieces are then sintered in an atmosphere controlled furnace at high temperatures, causing the metal powder particles to be metallurgically bonded together. This remarkably “green” and environmentally friendly process uses 99% of the material that’s in the mould, producing harmless by-products of nitrogen and hydrogen. [2]

Other answers considered.

(ii) Example 1. Car:

- Catalytic converter – to convert toxic exhaust emission from the engine into non toxic substances causing less harm to the environment.
- Start stop technology has been introduced into some cars to cut down on the use of fuels when the car is stationary.
- Hybrid car technology – the use of electric and fuel as the energy source to drive cars. This will reduce the use of non-renewable energy sources.

Other answers considered.

Example 2. Lights

- Mercury is an essential element in producing light in energy saving lamps and its amount will affect the performance of the lamps. CFL normally requires approximately 5 mg of mercury in order to deliver quality luminance. TBT has been striving to use as less mercury as possible while providing excellent performance.
- Instead of using liquid mercury, some companies have employed the latest technology using Amalgam as a substitution to minimize the impact to the environment. [4]

Other answers considered.

(f) (i) A sketch or sketches of a suitable design to communicate to parents or guardian how the harness needs to fitted using the following steps.

Level of response not worthy of credit.	[0]
Poor sketches. Difficulties in disseminating if the design would communicate how the harness is fitted.	[1]–[2]
Sketches are limited. The design lacks clarity in places or is confusing on how the harness is fitted.	[3]
Detailed quality sketches. The design is suitable for the product and communicates clearly how the harness should be fitted by the operator.	[4]–[5]

[5]

- (ii) Annotated sketches of a design of a footrest located as shown in Fig. 5(f).

Level of response not worthy of credit	[0]
Poor sketches with little or no annotation. Difficulties in disseminating if the design is suitable for the seat.	[1]–[2]
Annotated sketches are limited. The design is limited in certain aspects (profile, footrest, manufacturing and securing method).	[3]
Detailed annotated sketches. The design profile, footrest, manufacturing and securing method are suitable for the product.	[4]–[5]

[5]

AVAILABLE
MARKS

40

- 6 (a) Any **two** of the 6Rs.

Reduce – reduce the material used to produce the overall product profile. Reduce solid bar to tubing and minimise the need for temporary fastenings by including interference fits.

Recycle – design for ease of disassembly and ensure that materials are clearly labelled for recycling purposes. Avoid complex joining methods which present difficulty to recycle.

Reuse – The product after its life span for domestic waste could find many uses and be reused for external storage or as a composting unit.

Repair – The company can demonstrate how the product is designed with repair in mind. All sub assemblies are able to be replaced/repared with parts supplied on a cost effective basis.

Rethink – The company could claim to have rethought the entire design and manufacture process in order to prioritise and address environmental issues.

Refuse – the customer has the right to refuse to purchase the product if they feel that the company with its design and manufacture has not done everything in its power to address environmental issues. [4]
Other answers considered.

- (b) (i) This involves harnessing the temperatures in the Earth's surface to create electricity. By drilling two boreholes deep into the Earth's mantle or core, water passed down one of the boreholes would return up the other borehole as high pressure steam which could be used to drive turbines and create electricity. [2]

- (ii) Solar power as a renewable energy source:

- Photovoltaic cells converts light energy directly into electrical energy. These cells need to be exposed to intensive and continuous sunlight and are often arranged in long rows in huge solar farms.
- Solar panels – with metal pipes through which water is circulated these pipes are heated with sunlight raising the temperature of the water.

- Solar furnace – solar furnace collects heat energy concentrating it into a small area using a parabolic mirror. Intense heat is used to change water into high pressure steam. This in turn is used to drive a turbine generator to produce electricity. [2]

Other answers considered.

(c) (i) Any **two** advantages and **one** disadvantage:

Advantages

1. Telephone interviews can be an effective way of making contact with respondents and conducting short interviews which do not require any visual stimulus.
2. Quick gathering of information over any geographical distance and it is as flexible as the personal interview yet at a much lower cost.
3. An experienced interviewer with a good script can interview up to 50 respondents a day.

Disadvantage

1. The disadvantage is that non-phone owners are excluded from the research and also some people are reluctant to disclose certain information over the phone. [3]

Other answers considered.

(ii) Briefly explain the main characteristics associated with each of the following types of consumers:

- Fashion innovators – Fashion innovators adopt a new product first. They are interested in innovative and unique features. Marketing and promotion should emphasize the newness and distinctive features of the product.
- Masses – At the peak of its popularity, a fashion product is adopted by the masses. Marketing is through mass merchandisers and advertising to broad audiences.
- Laggards – As its popularity fades, the fashion product is often marked for clearance, to invite the bargain hunters and consumers, the late adopters and laggards, who are slow to recognize and adopt a fashionable style. [6]

Other answers considered.

(d) Introduction – The introductory phase of a product's life there are various pricing strategies which are possible; one option is to price the product low to stimulate sales and penetrate the potential market, this is known as a market penetration strategy. A contrasting strategy is to offer the product at a high price to reach a smaller target market and create an image of exclusiveness and quality, this is known as a market skimming strategy.

Growth – In the growth stage of a product's life the aim of the company will be to keep prices steady in order to encourage new and repeat purchasers. However in this phase of a product's life, once the competition is known it is possible that either the price of the product will be reduced to make the product more competitive or new features will be added to the basic product to give it added value for the same price.

Maturity – In the maturity stage of the life cycle similar strategies of price reduction or added value might be adopted to try and stimulate market demand and special price offers might be used to re-awaken interest in the product.

Decline – In the decline phase of a product’s life decisions will have to be made about how long the declining product can be sustained. The strategies adopted may not involve price changes but the company will look for ways in which to cut the costs that they incur in producing, distributing and marketing the product. [4]

(e) Memphis movement main points:

- Founded in 1981 by Ettore Sottsass, the group aimed to revive radical design.
- It was a reaction to the slick, black, humourless design of the 1970s with its minimalist design all of which were visually similar and in the eyes of the Memphis group devoid of personality and individualism.
- They created limited production creations of unusual objects and functional designs featuring plastic laminate surfaces, bright colours and bold patterns.
- Inspiration was drawn from such movements as the Art Deco and Pop Art, as well as the 1950s Kitsch styles and futuristic themes.
- They attempted to make a political statement and breakdown between high class and low class.
- It played a key role in the promotion of Italian design at a worldwide level.
- They encapsulated post modernist design in the 1980s challenging perceptions of ‘good design’ through their gaudy ornamental and decorative products.
- Many designers in graphic, interior and textile design is as strong today as it has ever been.
- Many contemporary designers looking for inspiration find many aspects of Memphis design invaluable to their work. [5]

Other answers considered.

Quality of written communication [4]

Level of response not worthy of credit.	[0]
Poor selection and use of a writing form and style appropriate to the content. The content is poorly organised and little use is made of appropriate Technological vocabulary. The writing is barely legible and the spelling, grammar and punctuation is inaccurate.	[1]–[2]
Good selection and use of a writing form and style appropriate to the content. The content is organised and use is made of appropriate Technological vocabulary. The writing is legible and the spelling, grammar and punctuation is accurate.	[3]
Very good selection and use of a writing form and style appropriate to the content. The content is well organised and good use is made of appropriate Technological vocabulary. The writing is clearly legible and the spelling, grammar and punctuation is very accurate.	[4]

(f) (i)

[5]

Level of response not worthy of credit.	[0]
Poor sketches with little or no annotation. Difficulties in disseminating if the design is suitable for the bin.	[1]–[2]
Annotated sketches are limited. The design is limited and may not be engaged or released quickly by the operator.	[3]
Detailed annotated sketches. The design is suitable for the product and clearly allows the operator to quickly engage or release the lid of the bin.	[4]–[5]

(ii)

[5]

Level of response not worthy of credit	[0]
Poor sketches with little or no annotation. Difficulties in disseminating if the design is appropriate for the bin.	[1]–[2]
Annotated sketches are limited. The design profile is suitable and the drainage design allows the user to remove the dirty water from the base and be replaced	[3]
Detailed annotated sketches. The design profile is clearly suitable and drainage design enables the user to remove the dirty water out of the base easily and be replaced securely after cleaning.	[4]–[5]

AVAILABLE
MARKS

40

Section C

40

Total

80