



Rewarding Learning

ADVANCED
General Certificate of Education
January 2013

Technology and Design

Assessment Unit A2 1

assessing

Systems and Control and
Product Design

[AV211]



FRIDAY 18 JANUARY, MORNING

TIME

2 hours.

INSTRUCTIONS TO CANDIDATES

Write your Centre Number and Candidate Number on the Answer Booklet provided and on the A3 pro forma answer pages provided.

Answer **both** questions in **either** Section A, Section B **or** Section C.

Answers to Questions **1(d)**, **2(e)**, **3(d)(i)**, **3(d)(ii)**, **4(c)(i)**, **4(c)(ii)**, **5(f)** and **6(f)** should be made on the A3 pro forma answer pages provided.

At the conclusion of the examination, attach the A3 pro forma answer pages securely to the Answer Booklet with the treasury tag supplied.

INFORMATION FOR CANDIDATES

The total mark for this paper is 80, including a maximum of 4 marks for quality of written communication.

Marks for quality of written communication will be awarded for Questions **1(e)**, **3(c)** and **5(d)**.

Figures in brackets printed down the right-hand side of pages indicate the marks awarded to each question or part question.



Answer **both** questions in **either** Section A, Section B **or** Section C.

Section A

Electronic/Microelectronic Systems

1 (a) A voltage divider circuit utilising a thermistor is shown in **Fig. 1(a)**.

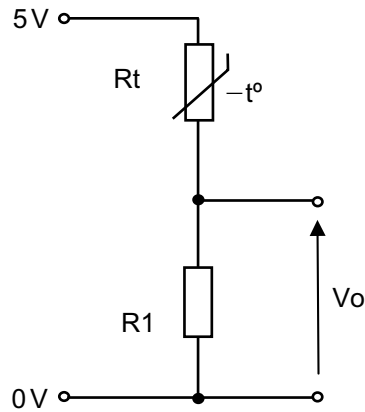

Fig. 1(a)

- (i) A thermistor can be used as the basis for a sensor to measure air temperature. State the main physical property of the thermistor that makes it suitable for this application. [1]
- (ii) Sketch and label a graph showing V_o against temperature for the voltage divider shown in **Fig. 1(a)**. Assume that the thermistor has a negative temperature coefficient. [2]
- (iii) The resistance of the thermistor shown in **Fig. 1(a)** can vary from $3.6\text{ k}\Omega$ to $4.8\text{ k}\Omega$. Calculate the corresponding values for V_o if R_1 has a value of $10\text{ k}\Omega$. [2]

(b) The output V_o from the voltage divider shown in **Fig. 1(a)** is connected to the analogue input of a PIC shown in **Fig. 1(b)** which has both analogue and digital inputs.

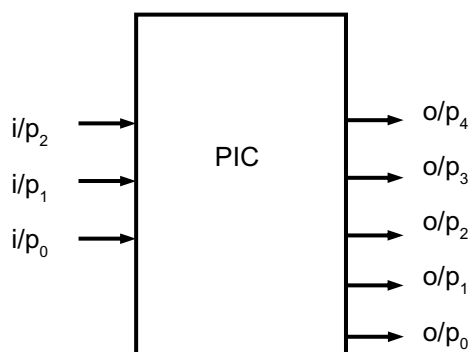

Fig. 1(b)

- (i) State the meaning of the term “analogue and digital inputs” when referring to a PIC. [2]
- (ii) The voltage of the analogue input to the PIC ranges from 0V to 5V and the corresponding digital range is 0 to 255. Calculate the analogue equivalent values that correspond to digital values of 51 and 153 respectively. [2]
- (iii) Explain how the ability of the PIC to “read” the input would be altered if the output V_o from the voltage divider shown in question 1(a) was connected to a digital input. [2]
- (c) A system for measuring the thermal expansion of materials is shown in Fig. 1(c). One end of the test material is held in a fixed clamp and the other end is held in a moving clamp. The moving clamp is connected to the sliding arm of a variable resistor. When the canopy is closed the air is heated to 60°C using a high voltage heater. A reading can then be observed on the digital meter.

The variable resistor used in the measuring system is of the linear sliding type and is also shown in Fig. 1(c) along with the corresponding symbol.

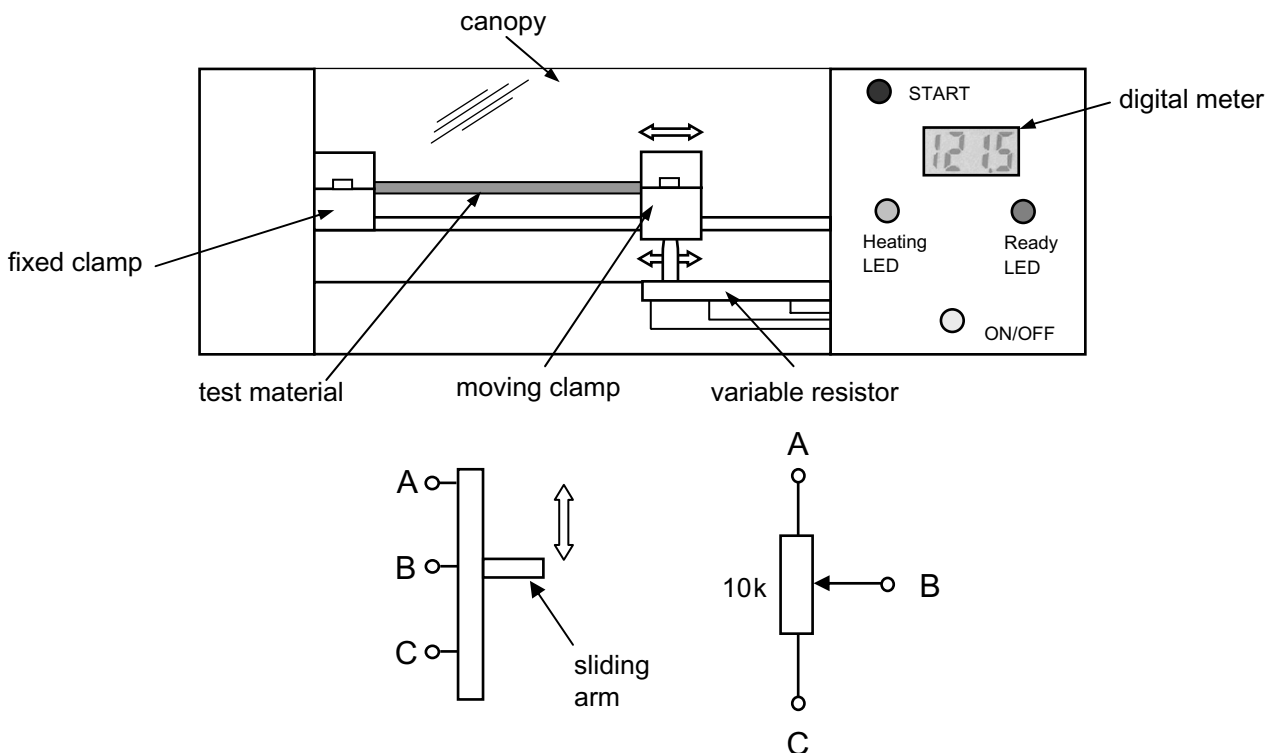

Fig. 1(c)

- (i) Sketch a graph with labelled axes to show how the resistance (measured between terminals A and B) changes as the sliding arm in Fig. 1(c) is moved from the mid-position shown towards terminal A. [2]

- (ii) With the aid of a circuit diagram show how the variable resistor shown in **Fig. 1(c)** could be connected to provide an output voltage that increases as the sliding arm is moved towards terminal A. [1]
- (iii) The voltage at terminal B in **Fig. 1(c)** is to be displayed on a digital meter. The maximum movement of the sliding arm of the variable resistor is 15 mm which produces a change in voltage at terminal B of 50 mV for every 0.1 mm moved. It is required that the voltage displayed by a digital meter, in millivolts, should represent the distance travelled by the sliding arm of the variable resistor i.e. the digital meter should display 1 mv when the wiper has moved by 0.001 mm. Determine the gain of an amplifier required to be connected between terminal B on the variable resistor and the digital meter to meet this requirement. [3]
- (iv) An amplifier based on an opamp is to be used in part **b(iii)** above where the gain of an inverting amplifier and a non-inverting amplifier is given by $-R_f/R_1$, and $1 + R_f/R_1$ respectively. Draw a suitable amplifier and specify suitable values for R_f and R_1 where R_f is the feedback resistor. [4]
- (d) The control panel for the measuring system shown in **Fig. 1(c)** has 2 LEDs, a heating LED to indicate that the heater is operational and a ready LED to indicate that the temperature has reached 60°C. Using electronic circuit diagrams on the blank pro forma provided (answer number **1(d)**), design a PIC based circuit and associated flow chart program that will fulfil the following:
- Once the on/off switch is operated the system will wait for the start switch to be pressed when a high voltage heater will begin to raise the air temperature.
 - The heating LED will illuminate and the temperature will be checked every 2 seconds.
 - When the temperature has reached 60°C the ready LED will illuminate while simultaneously sounding a buzzer. The high voltage heater and the heating LED will switch off.
 - After 30 seconds the ready LED and buzzer switch off and the system will wait for the start switch to be pressed again before repeating the sequence. [10]
- (e) When programming a PIC, **subroutines** and **loops** are often used. Outline the essential features of each of these programming techniques. Highlight the differences and illustrate your answer with specific examples of where each technique would be particularly suited. [5]
- Quality of written communication [4]

BLANK PAGE
(Questions continue overleaf)

- 2 (a) A prototype design for a security barrier is shown in **Fig. 2(a)**. The barrier which has a warning triangle attached is raised and lowered by a 12 volt DC motor and gearbox. Limit switches are positioned at A and B to determine when the barrier is fully up or down. The end support also contains a 12 volt solenoid operated lock to prevent anyone from trying to lift the barrier.

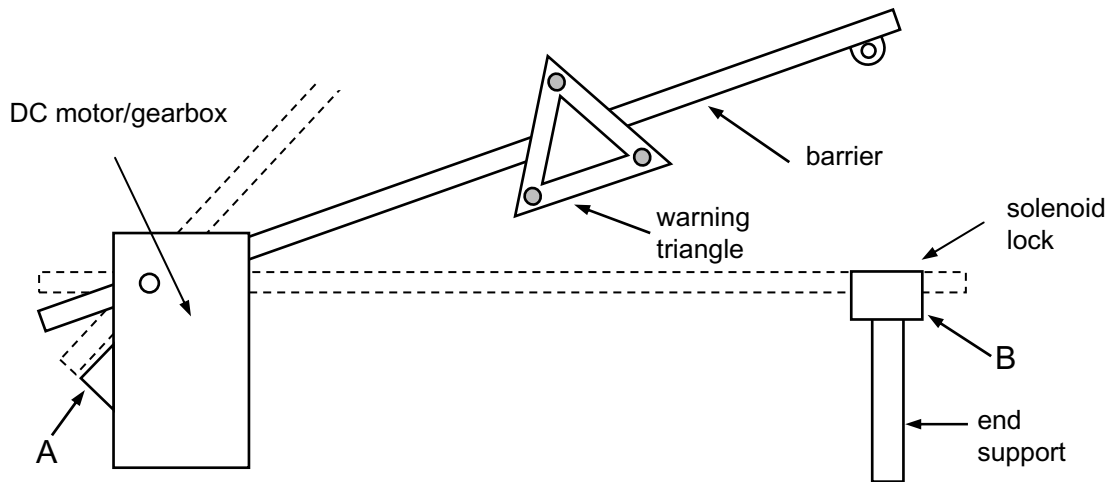

Fig. 2(a)

- (i) Name and draw a suitable non contact type switch that could be used to determine the limits of movement of the barrier at positions A and B in **Fig. 2(a)**. [2]
- (ii) State **two** advantages (other than cost) of using a DC motor rather than a stepper motor for raising and lowering the barrier shown in **Fig. 2(a)**. [2]
- (b) The warning triangle in **Fig. 2(a)** contains three 12 volt LED clusters that are controlled by a 5 volt logic circuit as shown in **Fig. 2(b)**. The logic circuit is driven by a 3 bit binary counter where a 0.2s pulse every 0.4s runs continuously to the clock input. The sequence is as follows:
- Cluster 1 only on for counter output stage 1.
 - Cluster 2 only on for counter output stage 2.
 - Cluster 3 only on for counter output stage 3.
 - All clusters off for the remaining counter stages.

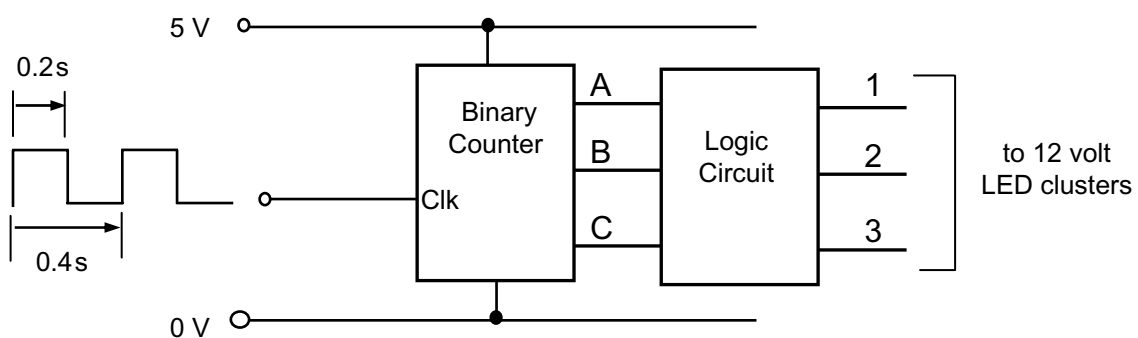

Fig. 2(b)

(i) Briefly explain the function of the clock input to a binary counter. [2]

(ii) With the aid of a labelled circuit diagram, design a means of producing the clock signal shown in Fig. 2(b). [4]

(iii) Draw a truth table to show all binary counter outputs A, B and C where C is the least significant bit (lsb), and the corresponding logic circuit outputs 1, 2 and 3 for the circuit shown in Fig. 2(b). [4]

(iv) Draw the logic circuit to control the LED clusters 1, 2 and 3. [3]

(c) Each LED cluster in Fig. 2(a) consists of 4 LEDs connected as shown in Fig. 2(c). The forward voltage of each LED is 2.2 volts and they are designed to operate with a current of 10 mA.

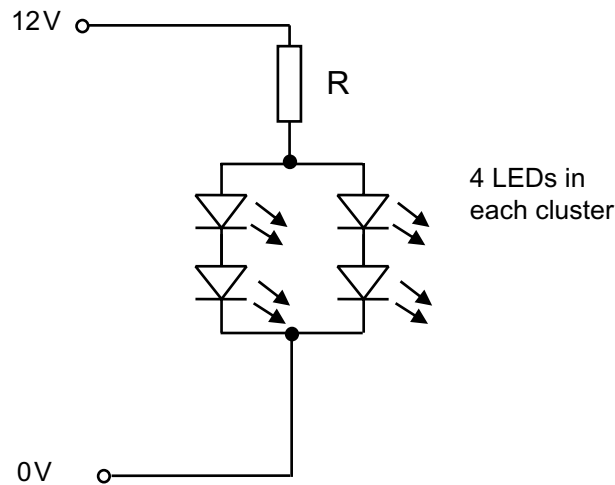

Fig. 2(c)

(i) Determine a suitable value for the protective resistor R. [2]

(ii) Give **two** main reasons (other than cost) why an LED type display is more suitable than an LCD type display for the warning triangle shown in Fig. 2(a). [2]

(iii) With the aid of a circuit diagram show how the output from the 5 volt logic circuit could be used to drive the 12 volt LED clusters shown in Fig. 2(c). [3]

(d) Drivers wishing to raise the security barrier are required to insert a plastic card into an optical reader. The cards have punched holes that have been specifically placed so that they can be read by a series of 3 phototransistors aligned with infrared transmitters as shown in **Fig. 2(d)** The card will also push a microswitch that will switch on the power supply to the phototransistors and infrared transmitters.

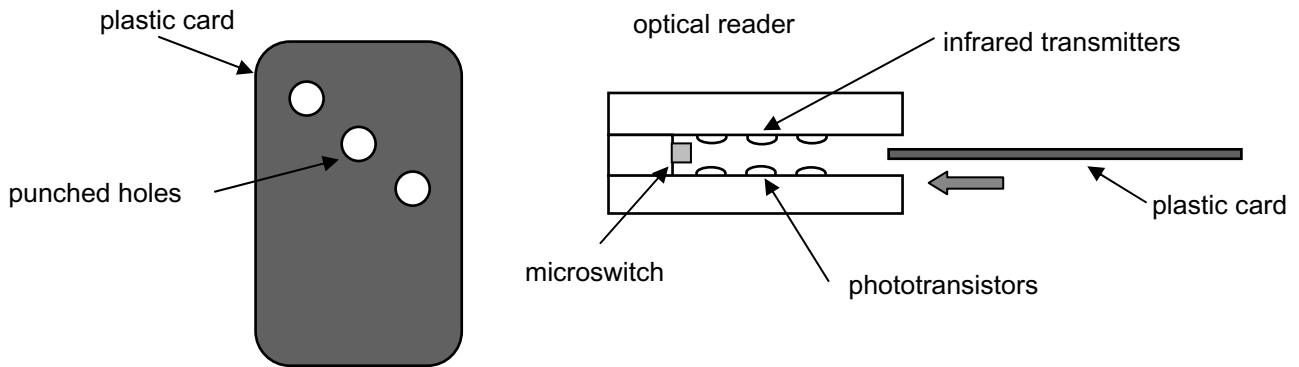

Fig. 2(d)

(i) Draw the circuit symbol for a phototransistor. [1]

(ii) Using an annotated circuit diagram, show how the 3 transmitters and phototransistors in **Fig. 2(d)** could be connected to provide a logic input to a circuit. The circuit should provide a “low” input when a plastic card with the correctly positioned punched holes allows all 3 phototransistors to operate when it is inserted into the optical reader. [5]

(e) When a driver has passed through the raised barrier they are required to press a push button switch that will lower the barrier and lock the solenoid. On the blank pro forma provided (answer number **2(e)**) draw an annotated circuit diagram to control the DC motor and achieve the following:

- Unlock the solenoid and raise the security barrier to its upper limit when a correct punched card is inserted into the reader.
- When the card is removed the barrier remains raised to its upper limit.
- Lower the barrier and lock the solenoid when the driver has pressed the switch.

[10]

BLANK PAGE
(Questions continue overleaf)

Answer **both** questions in **either** Section A, Section B **or** Section C.

Section B

Mechanical and Pneumatic Control systems

3 (a) Fig. 3a shows an image of a camshaft.

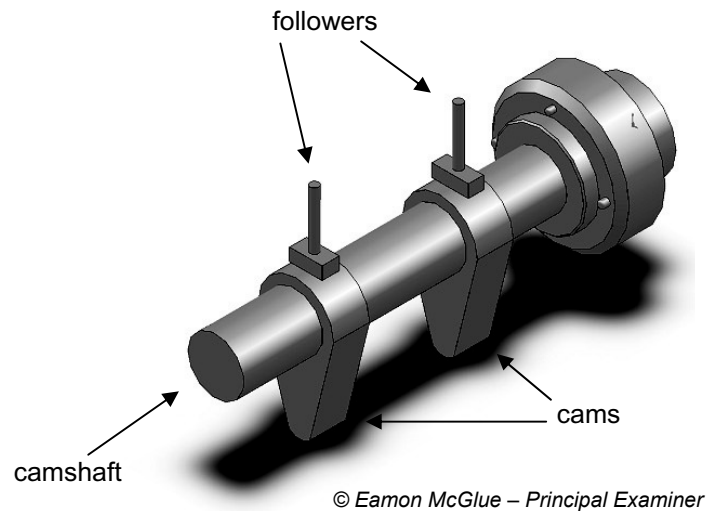

Fig. 3(a)

With reference to the camshaft, shown above in **Fig. 3(a)**:

- (i) Name and sketch another type of cam follower, apart from the flat follower shown, which can be used with cams. [2]
- (ii) The camshaft in **Fig. 3(a)** rotates at 180 rev/min, with a torque of 2.25 N m. Calculate the power expended. [3]
- (b) (i) Outline the difference between static and dynamic friction. [2]
- (ii) Using an annotated sketch draw and explain the operation of a typical drum brake system. [4]
- (c) Various moving parts in mechanical systems require lubrication mostly through the use of oil. Explain how lubricants are classified and outline the possible factors when selecting a lubricant for **two** different specific applications of your choice. [5]
- Quality of written communication [4]

(d) (i) The profile of a cam is determined by the performance/displacement diagram. **Fig. 3(d)(i)** below shows an incomplete diagram. On the pro forma provided (answer number **No. 3(d)(i)**) construct a performance/displacement diagram which would accurately produce the following motion:

- 0–150 rise 60 mm with uniform acceleration and retardation
- 150–240 fall by 20 mm with uniform velocity
- 240–360 fall 40 mm with simple harmonic motion.

[5]

A scale of 1 mm = 1 mm should be used. Do not answer on this diagram.

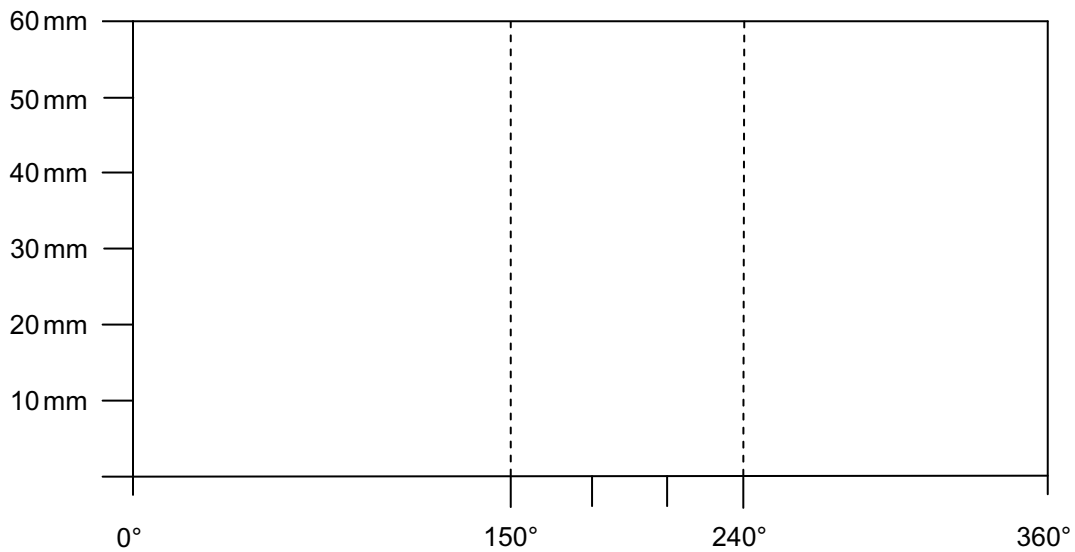

Fig. 3(d)(i)

(ii) Fig. 3(d)(ii) below shows a new performance/displacement diagram.

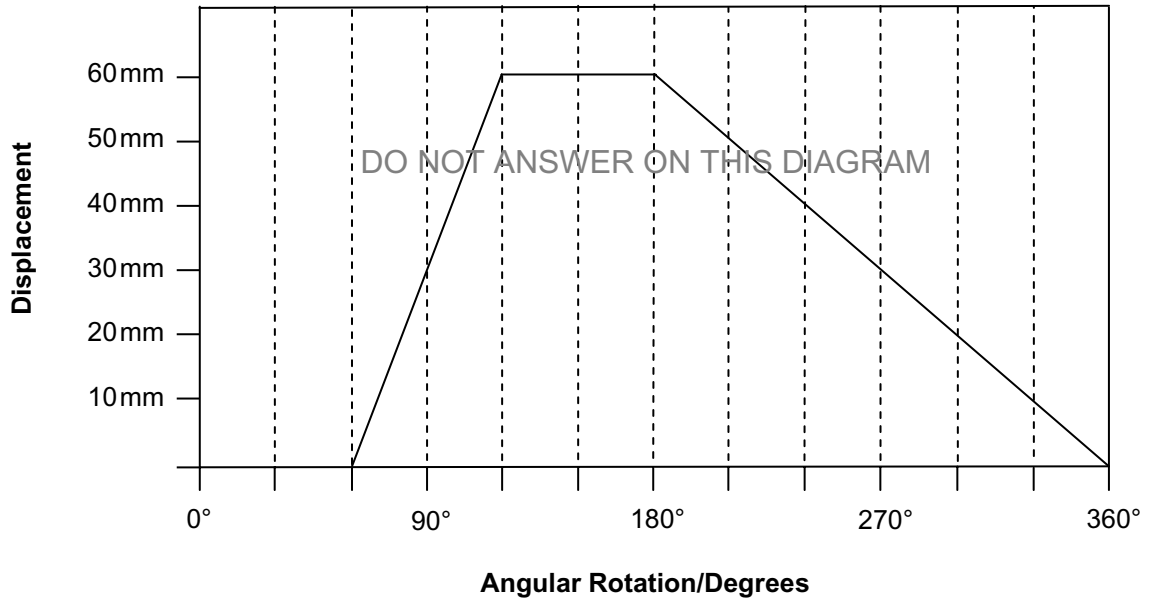

Fig. 3(d)(ii)

On the pro forma provided, (answer **No. 3 (d)(ii)**) using an appropriate drawing technique, construct a cam profile which would accurately follow the performance/displacement diagram. The minimum cam diameter is 60 mm with a shaft size of 20 mm. The follower is a roller follower and the cam rotates in a clockwise rotation. [5]

(e) With reference to **Fig. 3(e)(i)** and **Fig. 3(e)(ii)** opposite, which illustrate a wheel fixed to an axle and a chassis member, in your answer booklet complete the following:

- Select and draw an annotated sketch of a suitable bearing capable of dealing with considerable radial and axial loads.
- Design a housing for the bearing of your choice and show how it will be fixed to the chassis member. [5]

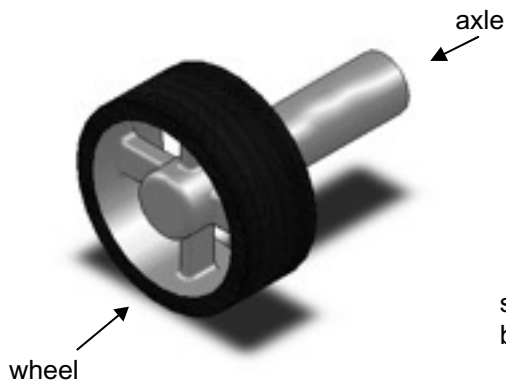

Fig. 3(e)(i)

© Eamon McGlue – Principal Examiner

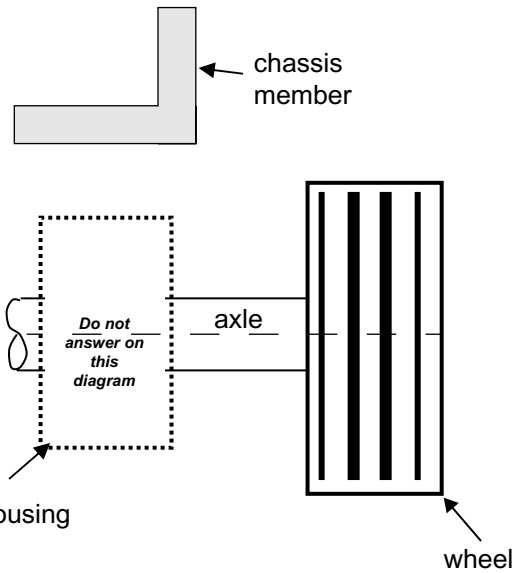

Fig. 3(e)(ii)

- Design a means by which the motion can be transmitted between the drive shafts shown in **Fig. 3(e)(iii)** below which are considerably out of alignment (fixed at an angle up to 20 degrees). Also, with reference to **Fig. 3(e)(iii)** suggest how your design can be secured to the shafts. [5]

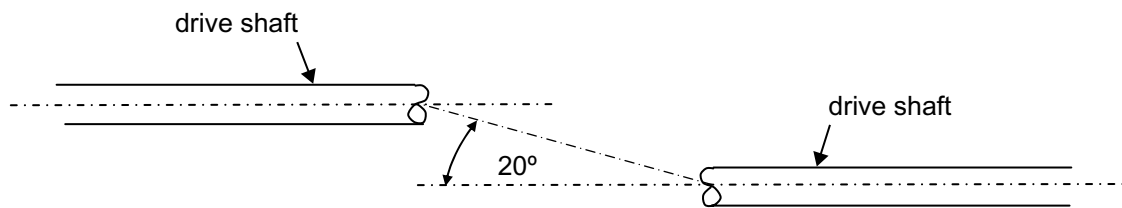

Fig. 3(e)(iii)

4 (a) Safety is an essential factor for any pneumatic circuit. Outline **two** main safety issues which arise when using pneumatics. [2]

(b) Fig. 4(b) below shows a circuit used to control a double acting cylinder for an industrial process.

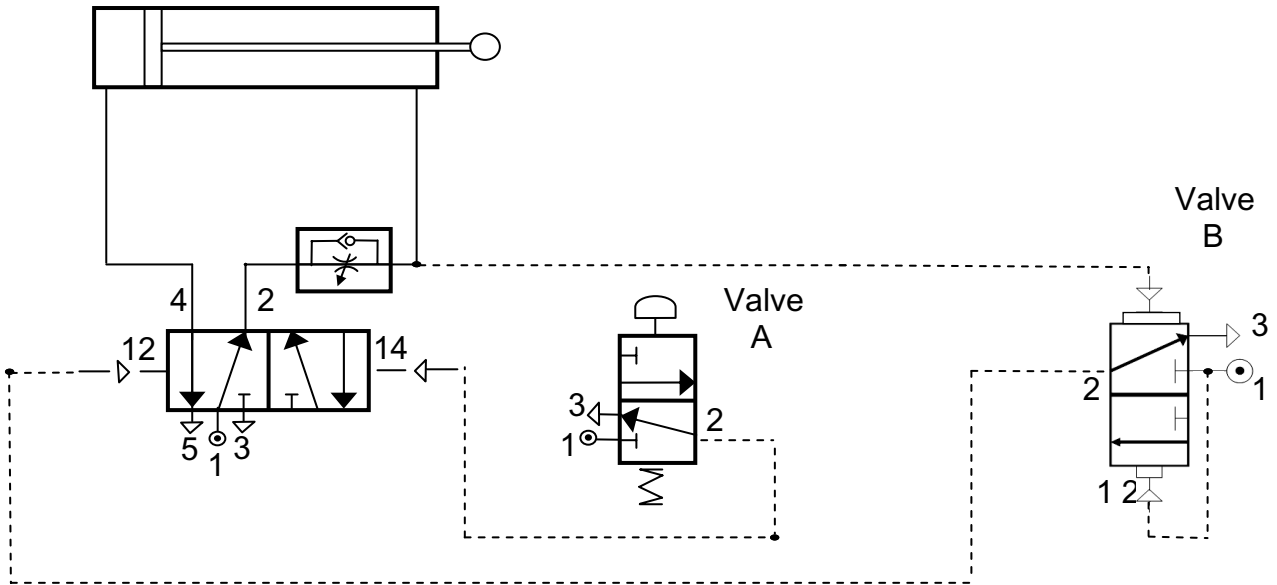

Fig. 4(b)

(i) Explain how the circuit in Fig. 4(b) operates starting from when valve A is pressed (your answer should include an explanation of all components). [4]

(ii) The double acting cylinder A (in Fig. 4(b)) has a stroke length of 200 mm and is calculated to exert a force during the outstroke of 300 N. Calculate the useful work done on the outstroke if the 300 N force loses 20% through inefficiency. [2]

(iii) The double acting cylinders B1, B2 and B3 in Fig. 4(b)(iii) below operate with an air pressure of 0.4 N/mm^2 with each producing a force of 1266.46 N during the outstroke. It is intended to replace B1, B2 and B3 with one large double acting cylinder. Calculate the piston radius of this replacement double acting cylinder which will operate at the same air pressure and produce the same overall force. Assume $\pi = 3.14$. [4]

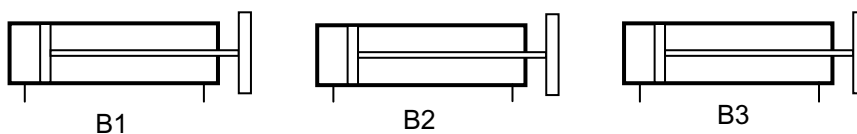

Fig. 4(b)(iii)

(iv) Proximity sensors are used on a range of pneumatic systems. Outline the main purpose of a proximity sensor and give a suitable application. [2]

(c) (i) On the pro forma provided (answer **No. 4(c)(i)**) draw a suitable sequential pneumatic circuit to achieve the desired sequence outlined. The pneumatic based system in **Fig. 4c(i)** is used in a potato factory and is operated from the control panel with the following sequence:

- The START 3PV is pressed and one side of the 5PV is selected by the lever.
- As a result cylinders A1 and A2 will outstroke.
- This in turn enables cylinders B1 and B2 to outstroke.
- This in turn enables cylinders C1 and C2 to outstroke.
- This in turn enables a time delay to begin and the grading selection cylinder (cylinder G) instrokes to change to the potato grading machine X.
- The cylinders A1 and A2 instroke, then B1 and B2 followed by C1 and C2.
- The operator then selects the other side of the 5PV by operating the lever and the sequence continues with the grading selection cylinder outstroking to change the potato grading machine Y. The sequence is then complete.
- Emergency stops can be activated from either position to stop the air supply. [16]

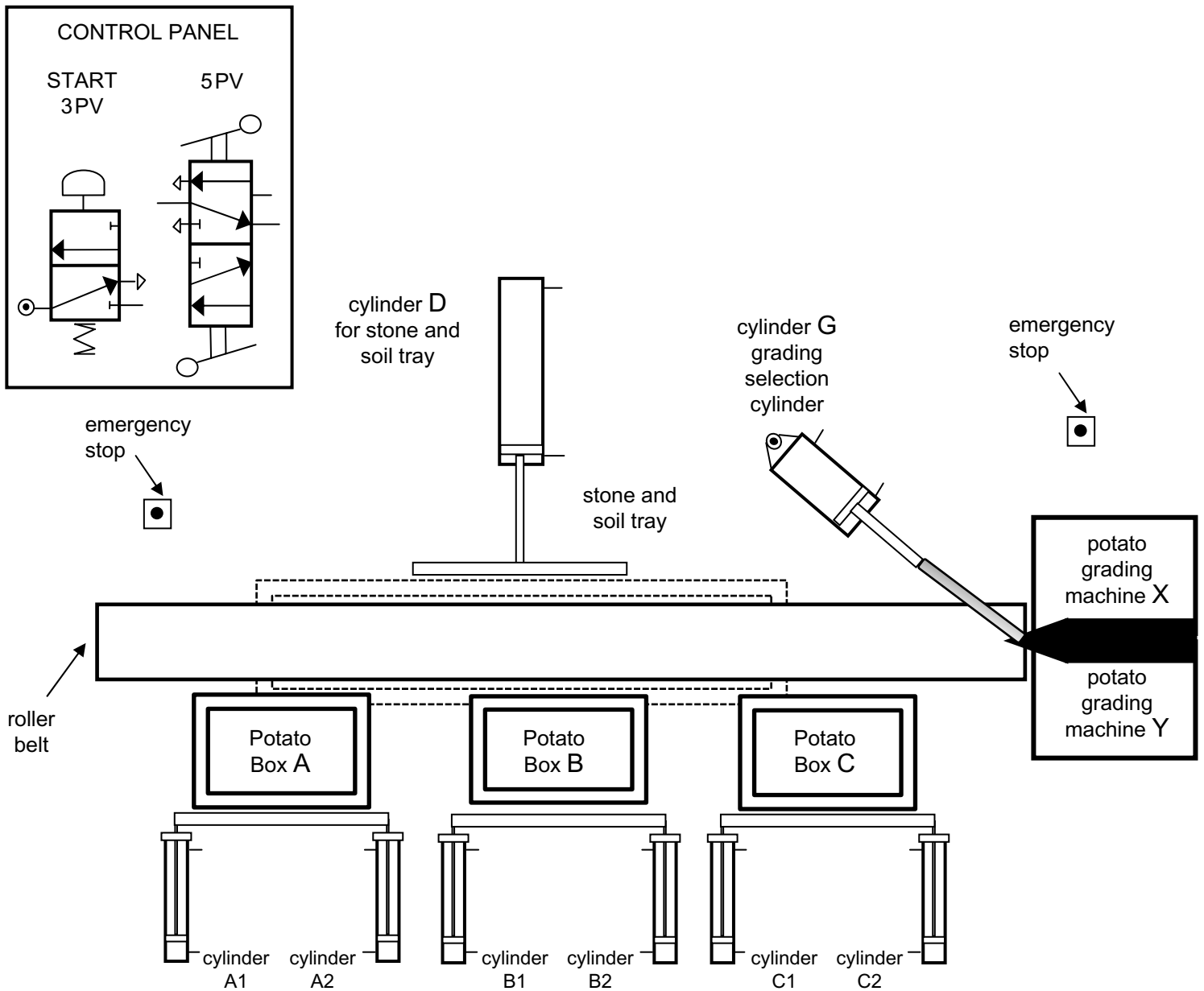

Fig. 4c(i)

(ii) With reference to **Fig. 4(c)(ii)** and (iii) below and opposite and using the pro forma provided (answer number **4(c)(ii)**) design and draw a system which will:

- Create a time delay and speed control on each box as it was discovered that the potatoes were emptying too fast, thus damaging them and also blocking the roller belt. The answer must involve the minimum number of components. [4]

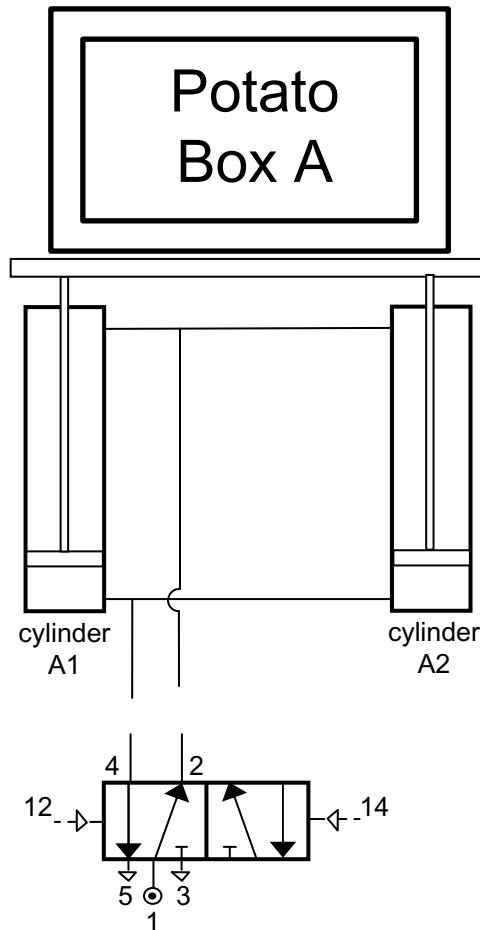

Fig. 4c(ii)

- Automatically detect that the stone and soil tray is full, then automatically empty the tray leaving it in position for future use.

[6]

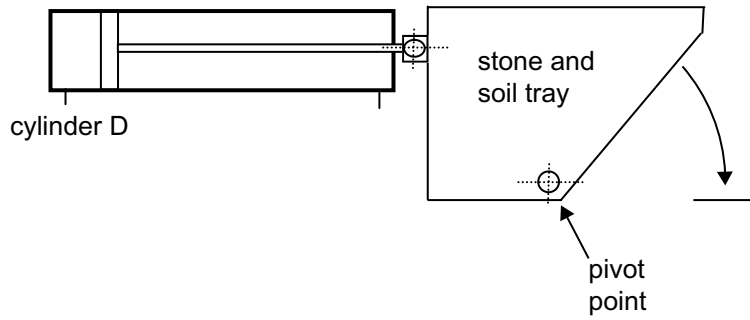
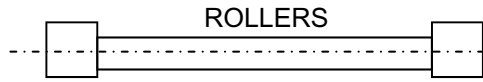

Fig. 4c(iii)

Answer **both** questions in **either** Section A, Section B **or** Section C.

Section C

Product Design

- 5 (a) **Fig. 5(a)** shows a photograph of a low cost wind-up radio aimed at the camping market. This product can be powered either by the user rotating the handle to wind up a dynamo or by the use of two AA batteries.



© D Neill - Chief Examiner

Fig. 5(a)

Some consumers may consider the wind-up radio as a fad product. Briefly explain the life cycle of a fad product. [2]

- (b) The creation of new products may be as a result of radical or incremental developments.
- (i) Briefly outline **two** key aspects associated with radical developments in the creation of new products. [2]
- (ii) Briefly outline **two** key aspects associated with incremental developments in the creation of new products. [2]

(c) (i) The wind up technology is to be prototyped as the energy source in a range of other electronic products. To determine the views of the consumer designers have turned to the use of product clinics and fixed consumer panels. Explain **two** main aspects associated with each of these strategies:

- A product clinic.
- A fixed consumer panel.

[4]

(ii) When determining a suitable price structure for the wind-up radio the company considered the following pricing methods;

- Cost-plus.
- Contribution pricing.
- Perceived value.

For the three methods listed above outline **two** main factors associated with each in order to guide the pricing for the wind-up radio. [6]

(d) The future challenge for some designers is to design products which will have a minimal impact on our environment.

For a specific product of your choice describe and justify how the environmental impact of this product has been reduced by its design. [5]

Quality of written communication

[4]

(e) The design of products such as the vacuum cleaner and the hand dryer have been greatly influenced by the work of Dyson.

Briefly outline **five** main factors which characterise the work and influence of Dyson. [5]

(f) **Fig. 5(f)** below shows the packaging to be used for the wind-up radio. A two part polystyrene unit houses the radio, batteries and literature. The unit is then set into a whiteboard box which has graphics printed on the exterior. The box is then completely sealed with cellophane ready for display or distribution to the customer.

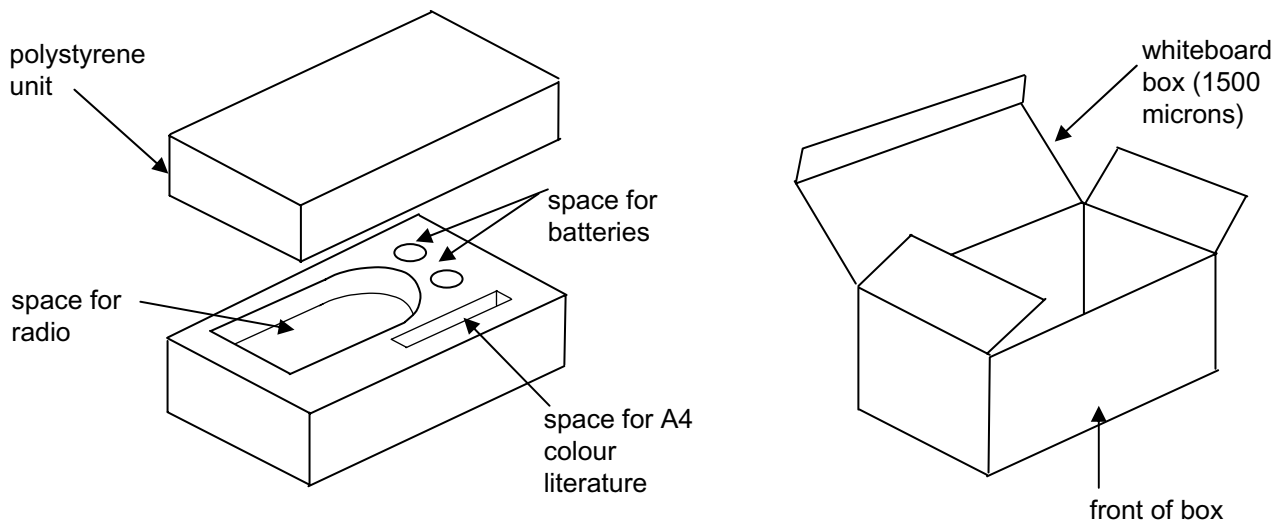

Fig. 5(f)

On the blank A3 pro forma provided (**answer number 5(f)**) produce **one** suitable solution for each of the following:

- An annotated rendered sketch of an innovative and appealing design for the front of the box which would communicate to the customer that: One minute of wind-up provides twenty minutes of playback. [4]
- An annotated sketch of a modification to the design above which would minimise the packaging material and wasted packaging space but still provide adequate protection to the product. In your answer provide a justification for your design and explain how the environmental impact of producing the packaging could be minimised. [6]

BLANK PAGE
(Questions continue overleaf)

- 6 (a) The electric kettle shown in **Fig. 6(a)** below comes in a range of designs, styles and colours.



© D Neill - Chief Examiner

Fig. 6(a)

Specification
<ul style="list-style-type: none">• Capacity 1.7 litres• Automatic switch off when boiled• Light indicator when heating• Boil dry protection• Ergonomically shaped handle• 230V – 50HZ 2200W with plug fused at 13A• Water level indicator.

For companies developing new product ranges in domestic appliances such as the electric kettle the information gained from market research is invaluable.

- (i) Explain why market research needs to be valid, reliable and representative. [2]

- (ii) The work of marketing information systems is to carry out a number of research tasks in order to gain a better understanding of the markets. With reference to the electric kettle outline the information that might arise from each of the following tasks:

- Market analysis
- Product research
- Distribution research.

[6]

- (b) Computer aided design (CAD) may have been employed in the design and manufacture of the electric kettle.

- Briefly outline **four** specific different ways in which CAD may have been employed in the design of the product. [4]

- (c) When marketing the electric kettle it is important for the company to select an appropriate promotional strategy and have an understanding of the places where this product is to be distributed and sold.
- (i) Outline **four** aspects of an appropriate promotional strategy that could be used when selling the electric kettle. [4]
- (ii) Place is one of the four P's and must be given careful consideration when selling the product. Outline **two** main considerations that the company would need to make with regards to Place. [4]
- (d) Devise and explain **two** appropriate tests that could be used to test the specification points outlined in **Fig. 6(a)** for the electric kettle. [4]
- (e) When addressing environmental issues the National government and the European Union (EU) can influence the design of products.
- (i) Outline **two** specific examples of how the National government has influenced the design of products. [4]
- (ii) Outline **one** specific example of how the European Union (EU) has influenced the design of a product. [2]

(f) Fig. 6(f)(i) below shows two views of the plug used for the electric kettle.



© D Neill - Chief Examiner

Fig. 6(f)(i)

On the blank A3 pro forma provided (answer **number 6(f)**) produce **one** suitable solution for the following:

- Annotated sketches of a device which would enable people with limited finger dexterity to remove the plug of the kettle shown in **Fig. 6(f)(i)** from the socket. Your answer should also explain how your design is suitable for medium to large scale production.

[5]

Fig. 6(f)(ii) below shows a drawing of a prototype kettle tipper designed to help the user when pouring liquids from the kettle.

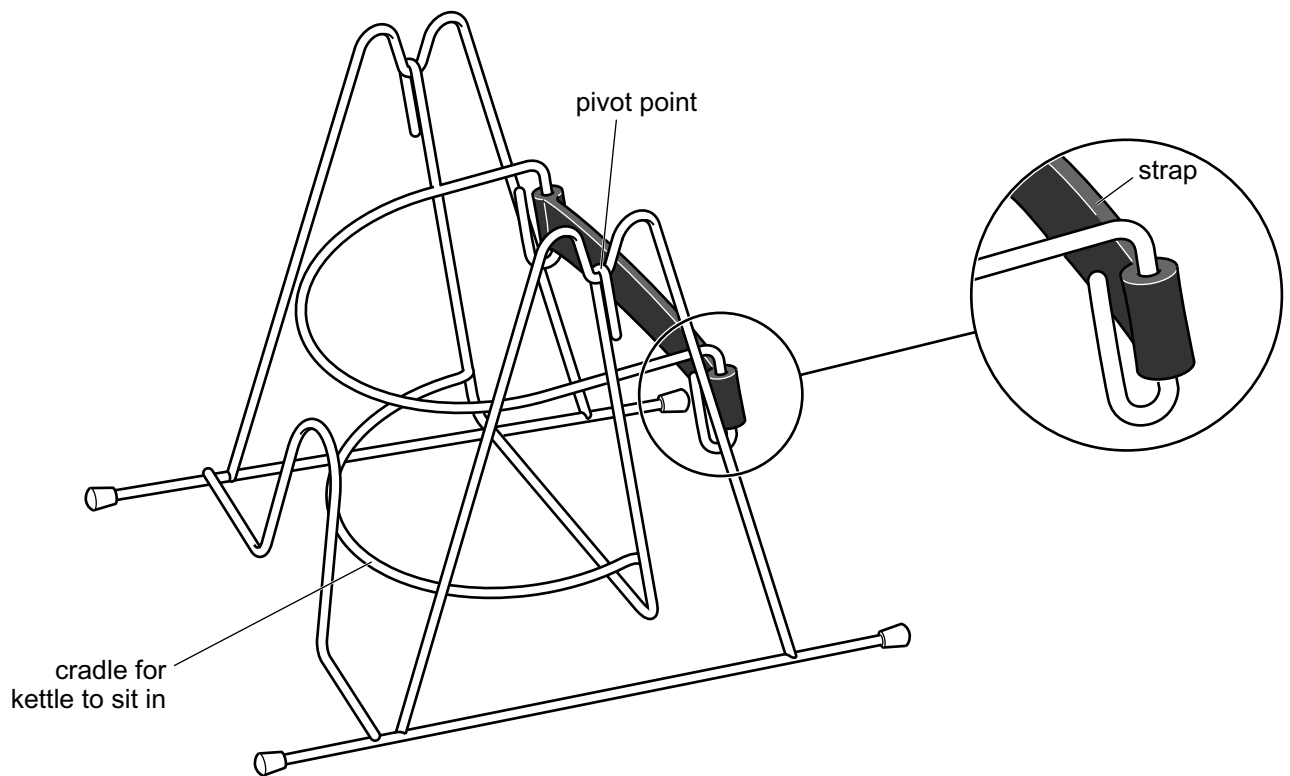

Fig. 6(f)(ii)

On the blank A3 pro forma provided (answer **number 6(f)**) produce **one** suitable solution for the following:

- Annotated sketches to show what changes you would make to the prototype kettle tipper shown in **Fig. 6(f)(ii)** so that it could be manufactured in plastic in large numbers. [5]

THIS IS THE END OF THE QUESTION PAPER

Permission to reproduce all copyright material has been applied for.
In some cases, efforts to contact copyright holders may have been unsuccessful and CCEA
will be happy to rectify any omissions of acknowledgement in future if notified.

Question No. 1(d)

ADVANCED LEVEL TECHNOLOGY AND DESIGN
ASSESSMENT UNIT A2 1
January 2013

Centre Number

71	
----	--

Candidate Number

--

Pro forma answer page
(answer number 1(d))

Question No. 2(e)

ADVANCED LEVEL TECHNOLOGY AND DESIGN
ASSESSMENT UNIT A2 1
January 2013

Centre Number

71	
----	--

Candidate Number

--

Pro forma answer page
(answer number 2(e))

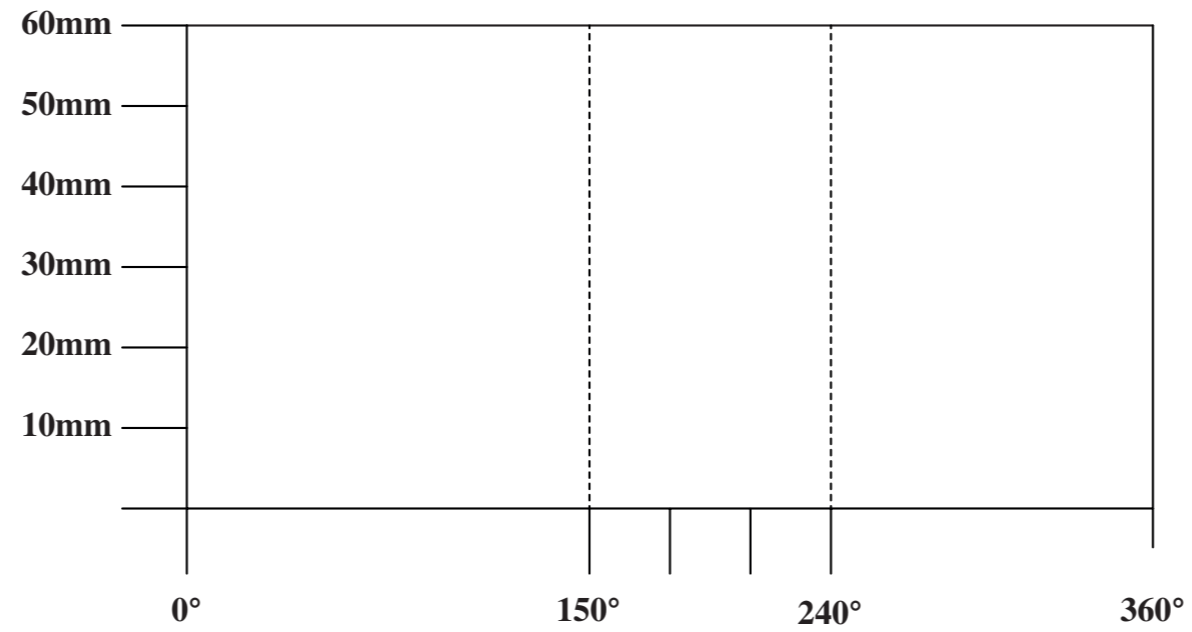

Pro forma answer page
(answer number 3(d)(i))

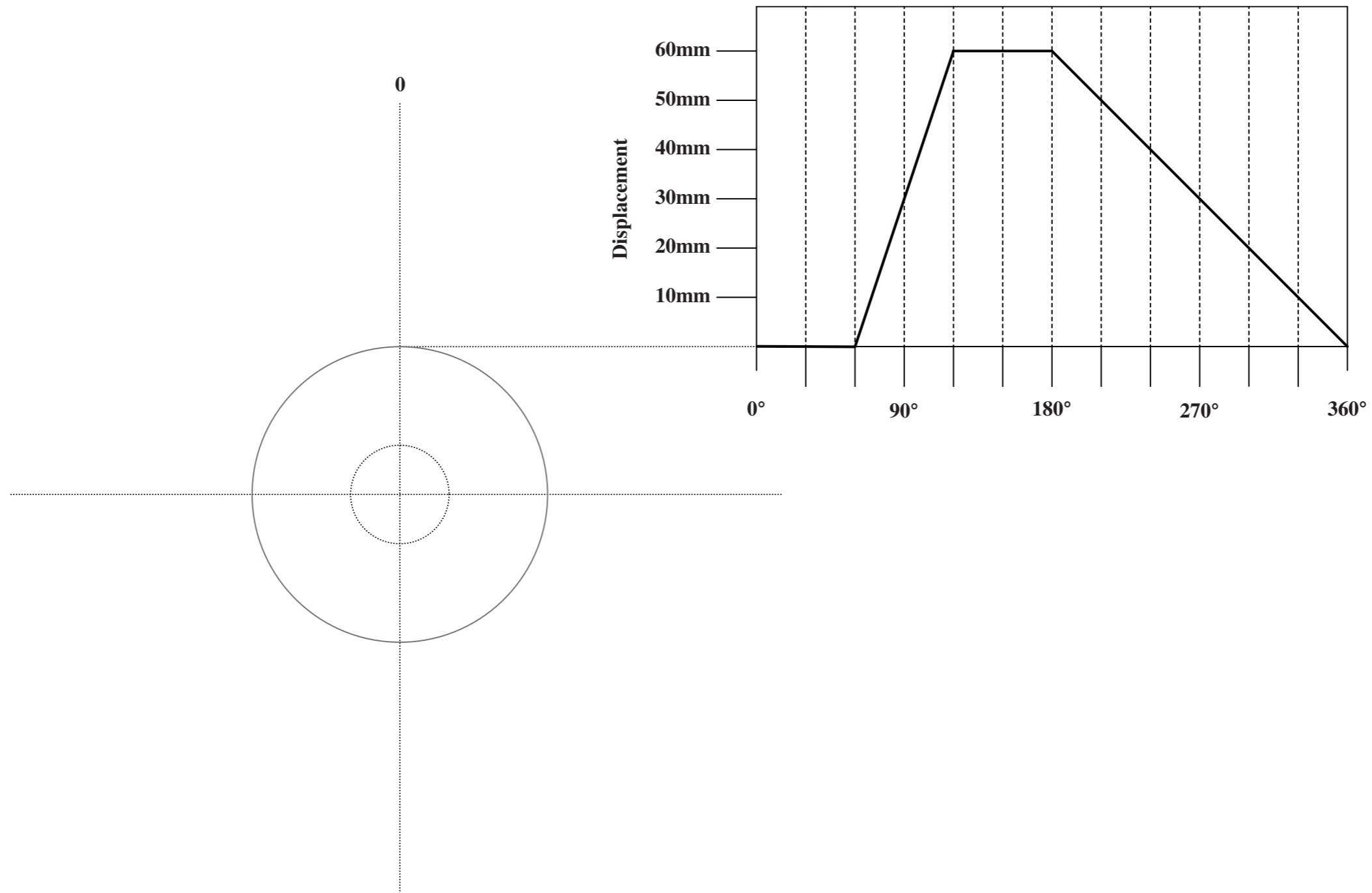

Pro forma answer page
(answer number 3(d)(ii))

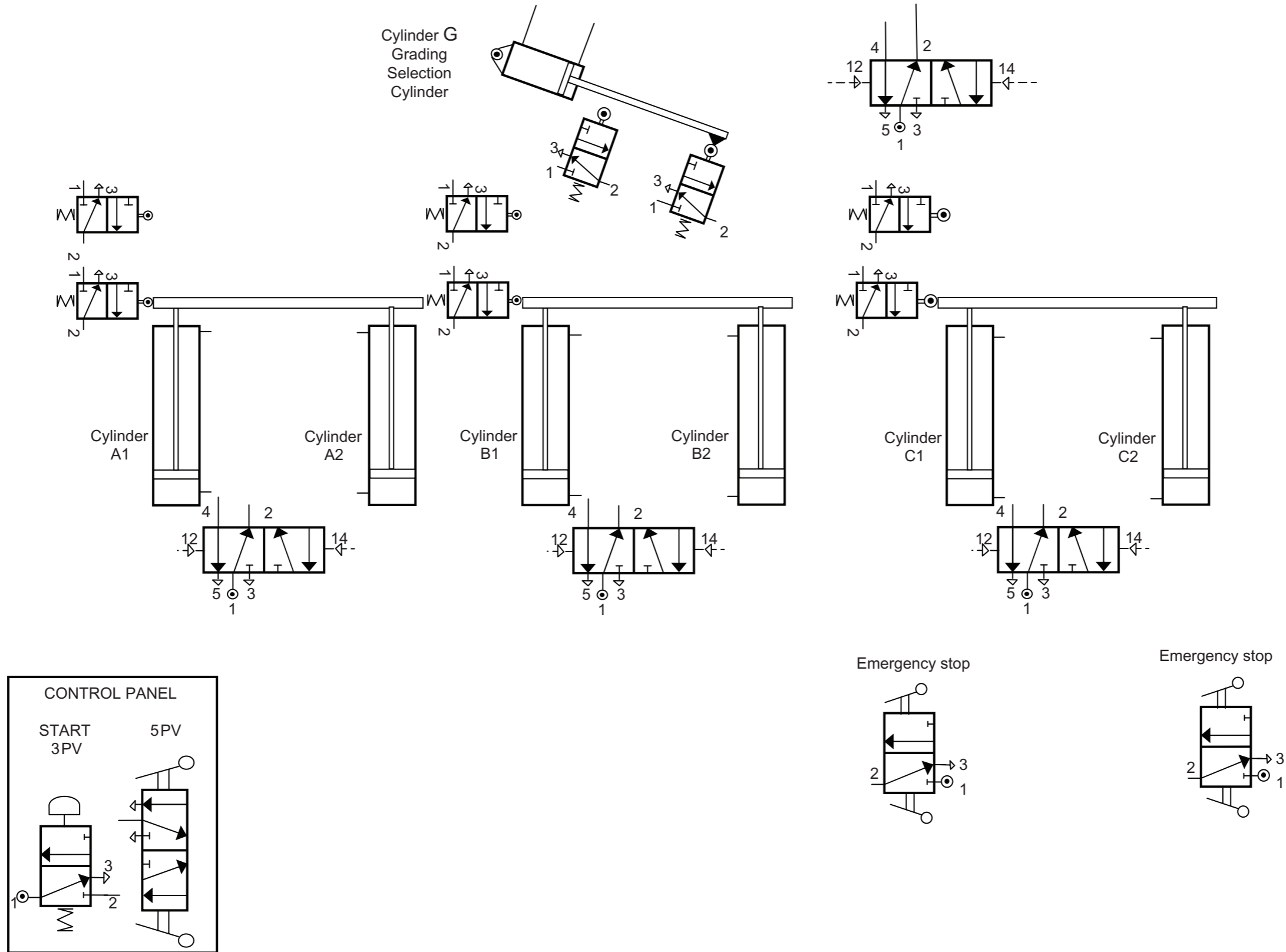

Pro forma answer page
(answer number 4(c)(i))

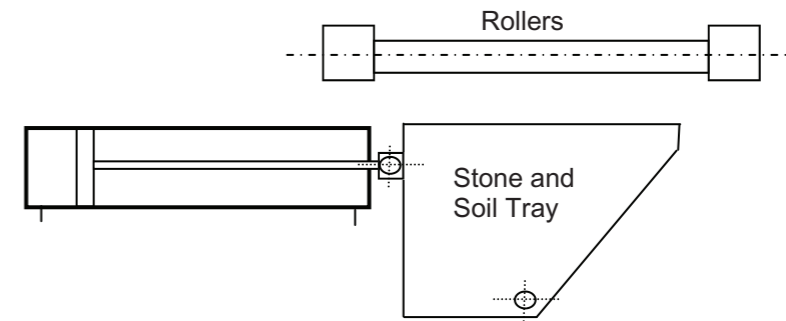
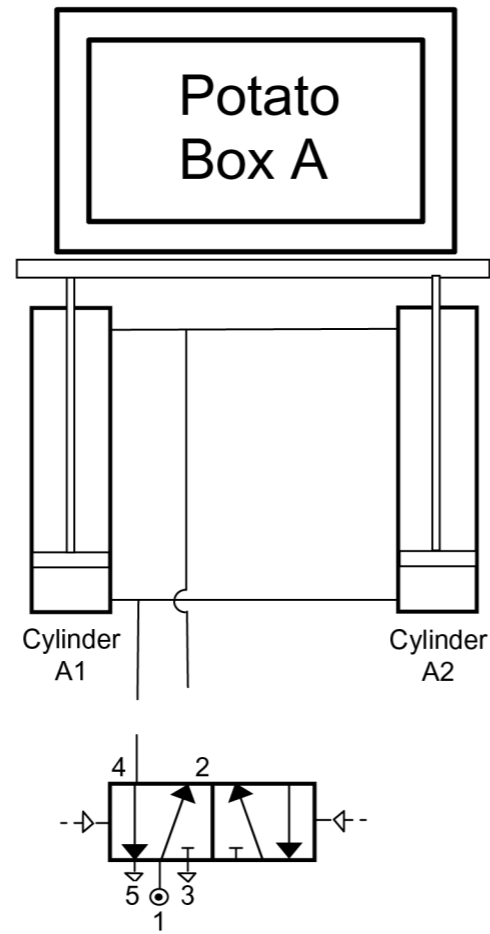

Pro forma answer page
(answer number 4(c)(ii))

Question No. 5(f)

ADVANCED LEVEL TECHNOLOGY AND DESIGN
ASSESSMENT UNIT A2 1
January 2013

Centre Number

71	
----	--

Candidate Number

--

Pro forma answer page
(answer number 5(f))

Question No. 6(f)

ADVANCED LEVEL TECHNOLOGY AND DESIGN
ASSESSMENT UNIT A2 1
January 2013

Centre Number

71	
----	--

Candidate Number

--

Pro forma answer page
(answer number 6(f))