



*Rewarding Learning*

**ADVANCED SUBSIDIARY (AS)  
General Certificate of Education  
2011**

---

## **Technology and Design**

**Assessment Unit AS 1**

*assessing*

**Product Design and Systems and Control**

**[AV111]**

**THURSDAY 23 JUNE, AFTERNOON**

---

**MARK  
SCHEME**

In all cases, correct alternative responses will be given full credit.

AVAILABLE  
MARKS

### Section A

- 1 Briefly explain what is meant by the following terms
- Toughness – this is the measure of how much energy is required to break a material [1]
  - Hardness – this is the measure of a material’s ability to withstand being scratched, cut or dented. [1]
  - Elasticity – is the ability of a material to return to an original state when a load has been removed. [1]
  - Plasticity – a materials ability to change shape permanently when subjected to force without cracking or breaking. [1]
- 2 A range of finishes are available for products manufactured from metal.
- (i) **two** main purposes of finishes used on metals
- metals look more attractive
  - protect them from the environment [2]
- (ii) Anodising – involves electrolysis and uses acids and electric currents to provide a durable corrosion resistant finish. [2]
- (iii) Lacquering – cleaning involves applying a lacquer with a brush or spray to prevent metals like brass and copper from tarnishing. [2]
- 3 Shape memory alloy and light-emitting polymers have a range of characteristics and applications.
- (i) **One** main characteristic for shape memory alloy:
- easily shaped when cool returns to a remembered shape when heated above a certain temperature
  - can be formed into practically any shape [1]
- One** specific application for shape memory alloy.  
e.g. mechanical actuation in robotic devices. [1]
- (ii) **One** main characteristic for light-emitting polymers:
- converts electrical power into visible light
  - by engineering the chemical structure of the LEP all emission colours can be obtained [1]
- One** specific application for light-emitting polymers.  
e.g. thin and lightweight displays for portable electronics. [1]

4

6

4

4 Blow moulding is commonly used to manufacture bottles, bowls and containers.

- (i) Reference to any **two** from the following:
- quick and efficient method
  - capable of producing hollow shapes with good definition
  - low cost when produced in numbers.
- [2]

- (ii) Blow moulding – Annotated sketch showing split mould, mandrel, plastic profile and mould opening for ejection. [3]  
Description [1]

AVAILABLE MARKS

6

5 (i) Any **two** specific characteristics associated with mass from the following:

- continuous or very large number of items produced
  - assembly line production used
  - only small or little variation to meet client requirements can be achieved
  - cheaper unit cost compared to the other two methods
  - less skilled labour required.
- [2]

- (ii) Any **two** specific characteristics associated with a flexible manufacturing system from the following:
- Based on flexible workforce and flexible machinery
  - People are semi-skilled – ability to adapt to a variety of tasks
  - Works best with batch production – flexibility essential.
- [2]

- (iii) Any **one** specific characteristic associated with concurrent engineering from the following:
- Stages of the design process can overlap
  - Good communication essential between all stages
  - Aim is to design/manufacture with maximum efficiency
- [1]

5

6 A company producing sports racquets uses computer aided design (CAD) and computer aided manufacture (CAM) to create new models of the product.

(i) Any **three** main advantages associated with the use of computer aided design (CAD) for the company from the following:

- Designs can be stored, edited and copied easily
- Designs can be easily viewed in 3D for clients
- Design ideas can be exported for rapid prototyping or manufacture
- Designs can be easily shared.

[3]

(ii) Any **two** main advantages associated with the use of computer aided manufacture (CAM) for the company from the following:

- Modifications can be made without expensive retooling costs
- Repeat jobs can be quickly downloaded
- Can save time and labour and reduce errors.

[2]

5

7 (i) Briefly explain what is meant by the term tolerance in relation to a component or product.

Component parts are manufactured within dimension guidelines known as tolerances. Tolerancing is concerned with what is acceptable for the part or parts to fit together or function.

[2]

(ii) Any **two** main reasons why it is so important for a company to test and inspect its products from the following:

- To avoid expensive recalls
- Ensure consistency/quality of product manufacture
- To avoid bad publicity
- To ensure the product or components are capable of doing what they were designed to do.

[2]

4

AVAILABLE  
MARKS

8 With reference to the mobile phone:

- (i) Any **two** different aspects of colour and what the designer has hoped to achieve with their use from the following:
- Silver/black – professional look
  - Silver/black – complementary
  - Red/green – associated with on/off
- [2]
- (ii) Incorporating symmetry – the elements of shape, form colour are the same on either side of an imaginary central line. [1]
- (iii) Incorporated proportion – key size. Screen size compared to overall size. [1]

Mark for clear and coherent explanation using good English grammar.

**QWC** [2]

6

AVAILABLE  
MARKS

**Section B**

**AVAILABLE MARKS**

9 (a) (i) Consists of resistors with 12 values for each multiple of 10. [2]

(ii) ● Resistance of LDR changes with light radiations.  
● Voltage divider provides a changing output voltage. [2]

(iii)  $V_o = 2.7V$  [2]

(b) (i)  $9V - 2V = 7\text{ volts}$  across R  
current =  $20\text{ mA} \times 2$  (parallel)  
therefore  $R = 7/40\text{ mA} = 175\Omega$ . [3]

(ii)  $P = V \times I = 7 \times 40\text{ mA} = 280\text{ mW}$ . [2]

(c)

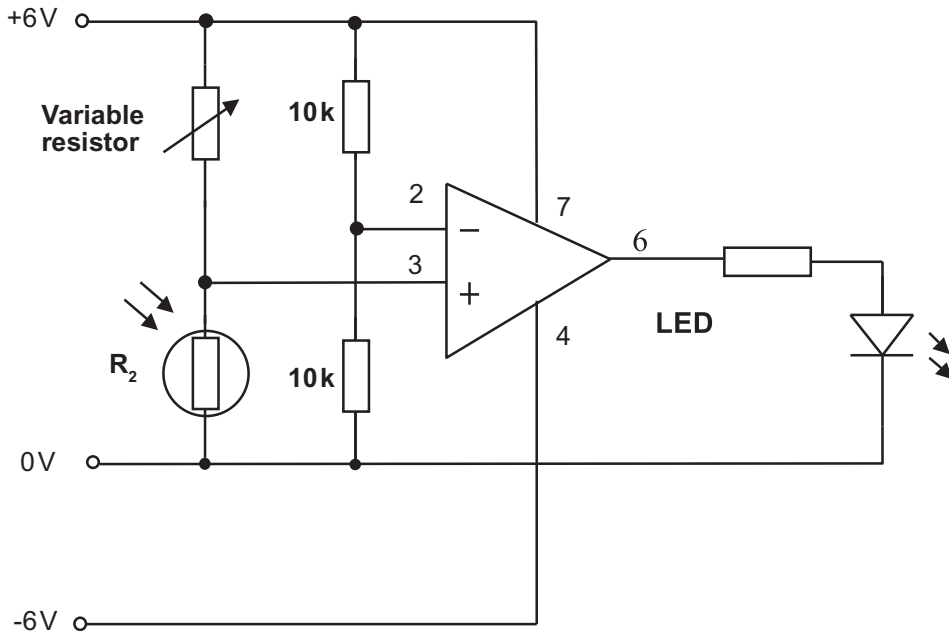

[6]

(d) Advantages of a programmable system

- reduced component count
- single power supply only required.

Disadvantages of a programmable system

- cannot provide a negative and positive output voltage, like the comparator
- cannot provide an amplified output
- requires programming software and downloading equipment. [2]

Mark for clear and coherent explanation using good English grammar.

**QWC [1]**

20

10 (a) (i) Not gate.

Truth table

A	Q
0	1
1	0

[2]

(ii)

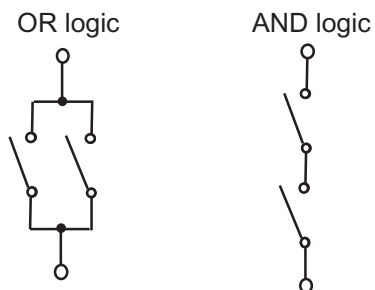

[2]

(b) (i) NAND Gate.

[1]

(ii) The resistors  $R_1$  and  $R_2$  are pull down resistors. They are used to ensure that the inputs to the logic circuit are not left to 'float' when the switches are opened.

[2]

AVAILABLE  
MARKS

(iii)

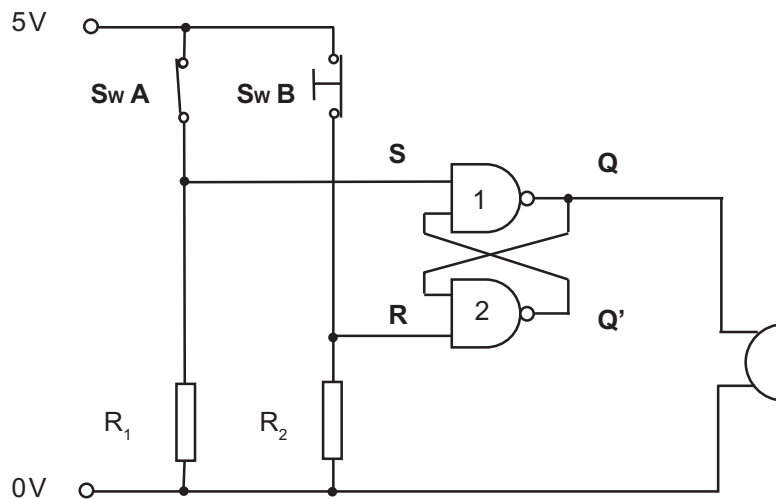

When both **Sw A** and **Sw B** are closed and we can assume that Q is at logic 0. This stable state means that a logic 0 and a logic 1 are the inputs to Gate 2 making Q' logic 1 and both inputs to Gate 1 are logic 1. If the microswitch **Sw A** is momentarily opened Q will be set to logic 1. This will cause both inputs to Gate 2 to be logic 1. This is the next stable state. (closing **Sw A** again will not change this stable state hence the output Q can be considered 'latched.')

The tamper alarm is reset by closing the microswitch **Sw A** and then opening **Sw B** momentarily.

Flip flop [1]  
Labels [1]  
Description [2]

Mark for clear and coherent explanation using good English grammar.

**QWC** [1]

AVAILABLE  
MARKS



(c) (i) Choose a standard value for C e.g. =  $100\ \mu\text{F}$   
therefore  $R = 20\ \text{s}/1.1 \times 100\ \mu\text{F} = 181.82\ \text{k}\Omega$

[2]

(ii)

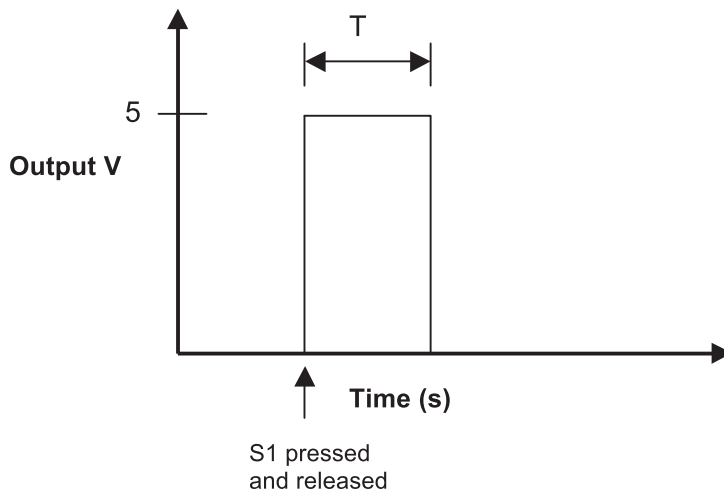

[3]

(iii)  $I_b = 100\ \text{mA}/80 = 1.25\ \text{mA}$   
Voltage across  $R_b = 5 - 0.7 = 4.3\ \text{V}$   
Therefore resistance =  $4.3/1.25\ \text{mA} = 3440\ \Omega$

[3]

AVAILABLE  
MARKS

20

### Section C

AVAILABLE  
MARKS

**11 Fig. 11(a)** shows a prototype industrial waste bin.

- (a) (i) The waste bin is an example of a class 2 lever. Briefly describe where the pivot/fulcrum is located when the bin is being moved.  
 Ans = The wheel acts as the fulcrum/lever when the bin is moving. [1]
- (ii) Calculate the effort required to move a 600 N load if the mechanical advantage is 3.  
 Ans =  $MA = \text{Load}/\text{Effort}$   
 $600/? = 3$   
 200 N [2]
- (iii) Calculate the velocity ratio of the waste bin if the distance moved by the load is 40 mm and effort moves 200 mm.  
 Ans =  $VR = \text{Distance moved by effort}/\text{distance moved by load}$ .  
 $VR = 200/40 = 5$  [2]

(b) **Fig. 11(b)** shows part of an incomplete industrial waste compacting system.

- (i) State the direction of rotation at **Gear O** if **B** rotates in an anticlockwise direction.  
 Ans = Anticlockwise [1]
- (ii) Calculate the output speed of **Wormwheel X** if the motor rotates at 480 rev/min.  
 Ans =  $OS = IS/VR$   
 $OS = 480/VR$   
 $VR = 160/80 = 2 \times 40 = 80$   
 $OS = 480/80 = 6 \text{ rev/min}$  [3]
- (iii) Calculate the size of **Wormwheel E** if it is expected to rotate at 5 rev/min.  
 Ans =  $OS = IS/VR$   
 $VR = 160/80 = 2$   
 $35/70 = 0.5$   
 $0.5 \times 2 = 1$   
 Speed at worm is 480 rev/min [1]  
 $5 = 480/96$   
 E has 96 teeth [2]

- (iv) Calculate the difference in output speeds between **Gears N** and **D**.

$$\begin{aligned} \text{Ans} = A-N &= 160/80 = 2 \\ &480/2 = 240 \\ A-D &= 160/80 = 2 \\ &35/70 = 0.5 \\ &2 \times 0.5 = 1 \\ &480/1 = 480 \end{aligned}$$

480 rev/min at D and 240 rev/min at N

Difference = 240 rev/min [3]

- (v) Using an annotated sketch draw a method which could use the motion provided by **Shaft Z** to make the compactor reciprocate.

Ans = Suitable annotated sketch outlining the following:

Crank [1]

Slider [1]

Or other suitable system.

- (vi) Name each type of gear and describe the change in transmission speeds between them from **Gear A** to **Wormwheel E**.

Ans=

Spur gear A meshes with spur gear B creating a transmission small speed reduction. Spur gear B is fixed to the same shaft as bevel gear C therefore there is no transmission speed change between them. Bevel gear C meshes with bevel gear D creating a small speed increase. The worm and wormwheel X create a significant speed reduction as the worm only accounts for a single driver tooth in a velocity ratio formula.

Or other suitable description. [2]

Mark for clear and coherent explanation using good English grammar.

**QWC** [1]

20

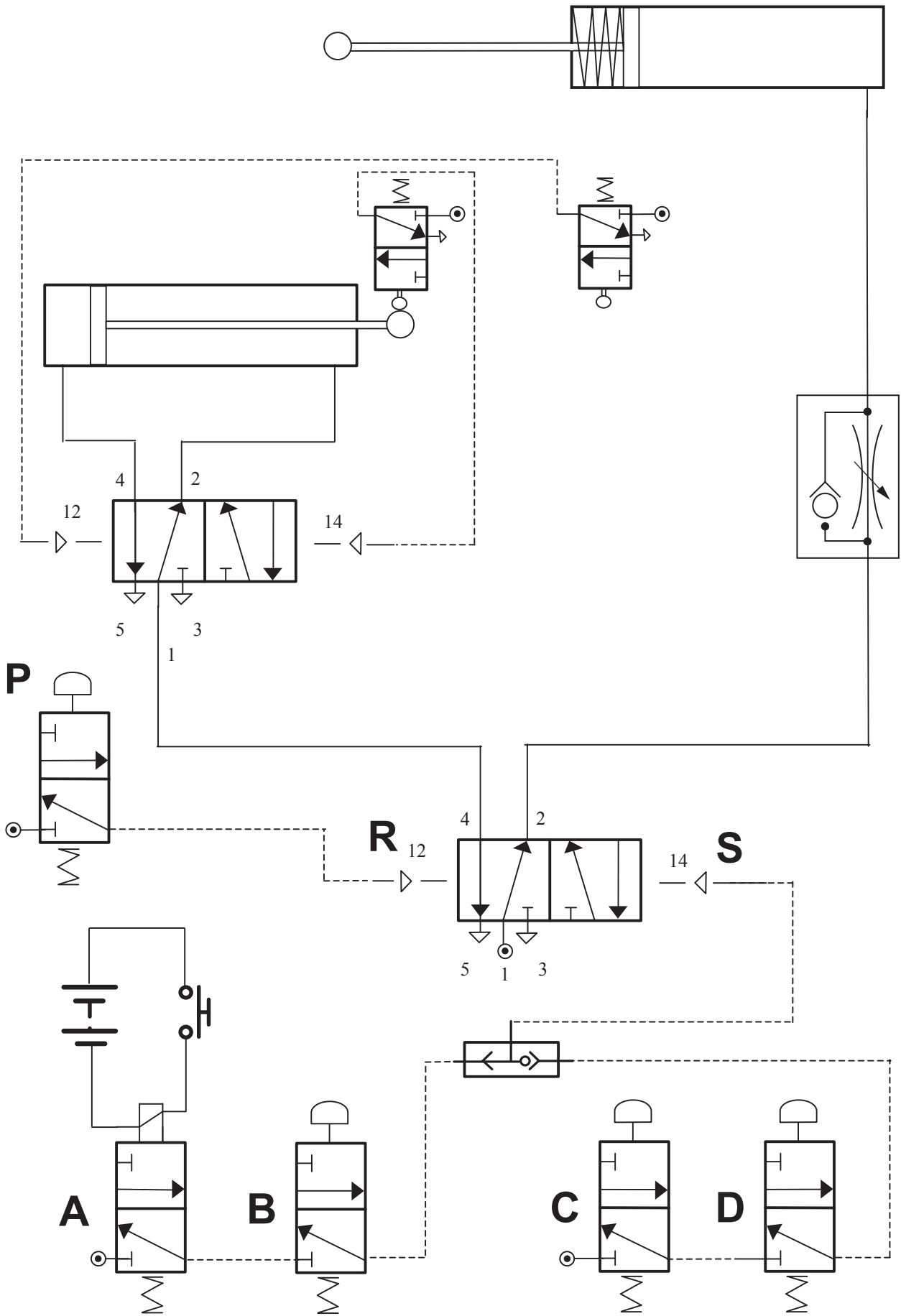

Answer No 12(b), (c) + (d)

12 Fig. 12 shows part of an incomplete pneumatic system.

- (a) (i) Name the activation method at **P**.  
 Ans = Push Button [1]
- (ii) Name the activation method at **R**.  
 Ans = Pilot/Signal Air [1]
- (iii) Name the activation method at **A**.  
 Ans = Solenoid [1]
- (b) An activation at **P** signals an outstroke on the single acting cylinder. On the pro forma provided (answer number **12(b)**, **(c)** and **(d)**) add an additional component which would allow speed control on the outstroke. [2]
- (c) On the pro forma provided (answer number **12(b)**, **(c)** and **(d)**) develop the circuit enabling a combined activation at **A** and **B** or **C** and **D** to activate the five port valve at **S**.  
 Ans = A and B [1]  
 C and D [1]  
 Shuttle valve [1]  
 Piping a connection to 5PV [1]  
 See sample answer.
- (d) On the pro forma provided (answer number **12(b)**, **(c)** and **(d)**) complete the circuit enabling the double acting cylinder to outstroke and instroke automatically once **S** is activated.  
 Ans = Piping to 5PV [1]  
 3PV with suitable activation method positioned suitably at outstroke. [2]  
 3PV with suitable activation method positioned suitably at instroke. [2]  
 See sample answer. [2]
- (e) (i) The double acting cylinder is supplied with an air pressure of  $0.4 \text{ N/mm}^2$ , has a piston diameter of 60 mm and a piston rod diameter of 6 mm. Calculate the difference in forces produced by the cylinder during the instroke in comparison with the outstroke. Please assume  $\pi = 3.14$ .  
 Ans =  $3 \times 3 = 9$   
 $9 \times 3.14 = 28.26 \text{ mm}^2$  [1]  
 $0.4 \times 28.26 = 11.3 \text{ N}$  [2]

(ii) Describe why there is a difference between the forces created during the outstroke and instroke.

Ans = Suitable answer outlining the forces created as a result of the different surface areas on each side of the piston. The piston rod reduces the effective surface area for the air to act on. [2]

Mark for clear and coherent explanation using good English grammar.

**QWC [1]**

20

**Total**

**80**

**AVAILABLE  
MARKS**