

**Published Mark Scheme for  
GCE A2 Technology and Design**

**January 2010**

Issued: April 2010  
Revised: June 2010



**NORTHERN IRELAND GENERAL CERTIFICATE OF SECONDARY EDUCATION (GCSE)  
AND NORTHERN IRELAND GENERAL CERTIFICATE OF EDUCATION (GCE)**

**MARK SCHEMES (2010)**

**Foreword**

***Introduction***

Mark Schemes are published to assist teachers and students in their preparation for examinations. Through the mark schemes teachers and students will be able to see what examiners are looking for in response to questions and exactly where the marks have been awarded. The publishing of the mark schemes may help to show that examiners are not concerned about finding out what a student does not know but rather with rewarding students for what they do know.

***The Purpose of Mark Schemes***

Examination papers are set and revised by teams of examiners and revisers appointed by the Council. The teams of examiners and revisers include experienced teachers who are familiar with the level and standards expected of 16- and 18-year-old students in schools and colleges. The job of the examiners is to set the questions and the mark schemes; and the job of the revisers is to review the questions and mark schemes commenting on a large range of issues about which they must be satisfied before the question papers and mark schemes are finalised.

The questions and the mark schemes are developed in association with each other so that the issues of differentiation and positive achievement can be addressed right from the start. Mark schemes therefore are regarded as a part of an integral process which begins with the setting of questions and ends with the marking of the examination.

The main purpose of the mark scheme is to provide a uniform basis for the marking process so that all the markers are following exactly the same instructions and making the same judgements in so far as this is possible. Before marking begins a standardising meeting is held where all the markers are briefed using the mark scheme and samples of the students' work in the form of scripts. Consideration is also given at this stage to any comments on the operational papers received from teachers and their organisations. During this meeting, and up to and including the end of the marking, there is provision for amendments to be made to the mark scheme. What is published represents this final form of the mark scheme.

It is important to recognise that in some cases there may well be other correct responses which are equally acceptable to those published: the mark scheme can only cover those responses which emerged in the examination. There may also be instances where certain judgements may have to be left to the experience of the examiner, for example, where there is no absolute correct response – all teachers will be familiar with making such judgements.

The Council hopes that the mark schemes will be viewed and used in a constructive way as a further support to the teaching and learning processes.



## CONTENTS

|  | <b>Page</b> |
|--|-------------|
| A2 1: Product Design and Systems and Control | 1           |



New  
Specification



*Rewarding Learning*

**ADVANCED**  
**General Certificate of Education**  
**January 2010**

---

## **Technology and Design**

**Assessment Unit A2 1**

*assessing*

**Product Design and Systems and Control**

**[AV211]**

**WEDNESDAY 27 JANUARY, MORNING**

---

# **MARK SCHEME**

## **General Marking Instructions**

These mark schemes are intended to ensure that the AS/A2 examinations are marked consistently and fairly. The mark schemes provide examiners with an indication of the nature and range of candidate responses likely to be worthy of credit. They also set out the criteria which they should apply in allocating marks to candidates' responses. The mark schemes should be read in conjunction with these general marking instructions which apply to all papers.

## **Quality of candidates' responses**

In marking the examination papers, examiners will be looking for a quality of response reflecting the level of maturity which may reasonably be expected of 17- and 18-year-olds which is the age at which the majority of candidates sit their AS/A2 examinations.

## **Flexibility in marking**

The mark schemes which accompany the specimen examination papers are not intended to be totally prescriptive. For many questions, there may be a number of equally legitimate responses and different methods by which the candidates may achieve good marks. No mark scheme can cover all the answers which candidates may produce. In the event of unanticipated answers, examiners are expected to use their professional judgement to assess the validity of answers. If an answer is particularly problematic, then examiners should seek the guidance of the Supervising Examiner for the paper concerned.

## **Positive marking**

Examiners are encouraged to be positive in their marking, giving appropriate credit for valid responses rather than penalising candidates for errors or omissions. Examiners should make use of the whole of the available mark range for any particular question and be prepared to award full marks for a response which is as good as might reasonably be expected for 17- and 18-year-old candidates. Conversely, marks should only be awarded for valid responses and not given for an attempt which is completely incorrect and inappropriate.

## **Types of mark schemes**

Mark schemes for questions which required candidates to respond in extended written form are marked on the basis of levels of response which take account of the quality of written communication. These questions are indicated on the cover of the examination paper.

Other questions which require only short answers are marked on a point for point basis with marks awarded for each valid piece of information provided.

## **Quality of written communication**

Quality of written communication is taken into account in assessing candidates' responses to all questions that require them to respond in extended written form.



In all cases, correct alternative responses will be given full credit.

Section A

1 (a) (i) To protect the LED segments by limiting the current. [1]

(ii) Common anode – all anodes from the LEDs are connected to a common point at the positive voltage supply. Common cathode – all cathodes from the LEDs are connected to a common point at the negative voltage supply. In this instance a common cathode display is shown. [2]

(iii) Truth table

| S <sub>3</sub> | S <sub>2</sub> | S <sub>1</sub> | B | A |
|----------------|----------------|----------------|---|---|
| 0              | 0              | 0              | 0 | 0 |
| 0              | 0              | 1              | 0 | 1 |
| 0              | 1              | 0              | 0 | 0 |
| 0              | 1              | 1              | 1 | 0 |
| 1              | 0              | 0              | 0 | 0 |
| 1              | 0              | 1              | 0 | 0 |
| 1              | 1              | 0              | 0 | 0 |
| 1              | 1              | 1              | 1 | 1 |

Table 1

[3]

(iv) minimised logic expressions for A and B

$$A = S_1 S_2' S_3' + S_1 S_2 S_3$$

$$B = S_1 S_2$$

[4]

(v) logic gates

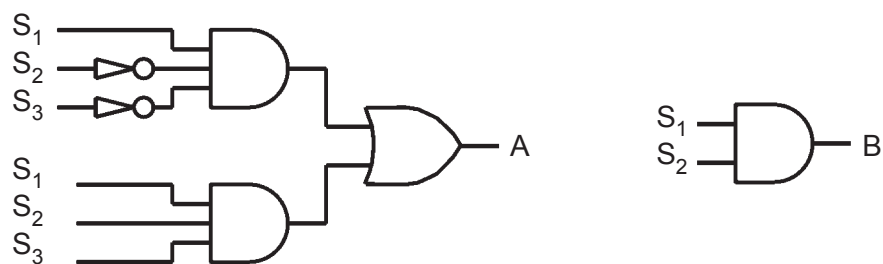

[2]

- (vi) They are unused inputs therefore they are 'pulled down' to ensure a logic zero. [2]
- (b) (i) Clearly labelled gauge with the passive and active axis. [2]
- (ii)  $V_1 = 2.49V$  [2]
- (iii) Bullet point 1 gain = 20 [1]
- Bullet point 2  $R_i = 10k$   $R_f = 200k$  [2]
- (iv) Answer to include a structured and coherent written presentation with reference to the following:
  - main issues – 1. overheating leading to burn hazard or fire hazard
  - 2. insulation breakdown – leading to electric shock risk
  - 3. exposed high voltage components – electric shock risk

Risk minimised by use of 1. thermal cutouts 2. correctly rated fuses to prevent overloading and 3. use of RCB circuit breakers

Procedures – justification of:

  - checking power rating of components
  - extensive bench testing under full load conditions
  - ensuring power supplies and power cables have been regularly checked.
  - provision of appropriate fire extinguishers [5]

Quality of written communication

|   |     |
|---|-----|
| Poor selection and use of a writing form and style appropriate to the content. The script content is poorly organised and little use is made of appropriate technological vocabulary. The writing is barely legible and the spelling, grammar and punctuation is inaccurate.      | 0–2 |
| Good selection and use of a writing form and style appropriate to the content. The script content is organised and use is made of appropriate technological vocabulary. The writing is legible and the spelling, grammar and punctuation is accurate.                             | 3   |
| Very good selection and use of a writing form and style appropriate to the content. The script content is well organised and good use is made of appropriate technological vocabulary. The writing is clearly legible and the spelling, grammar and punctuation is very accurate. | 4   |

[4]

(c) (i)

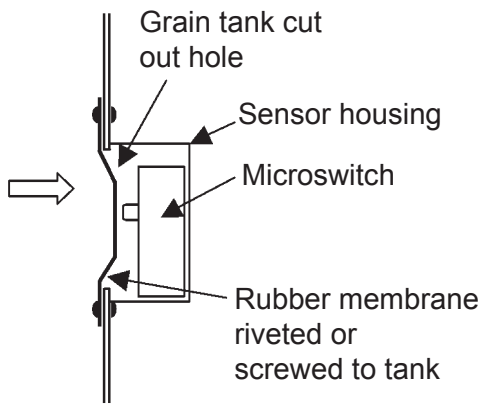

When grain pushes against the rubber membrane, it will deform and the microswitch will be actuated. Membrane movement will be limited by the microswitch

[4]

(ii) Answer could include an astable timer to be started when S3 is activated. The output from this used to control the 7 segment display

[6]

2 (a) (i)

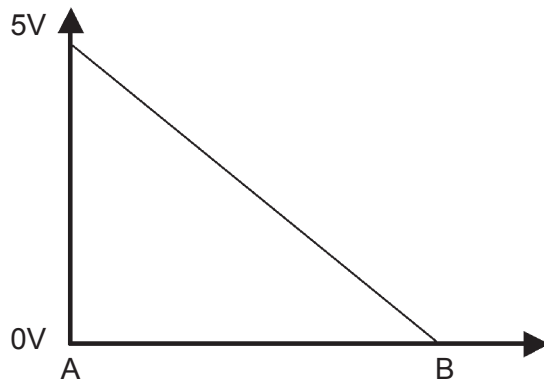

[3]

(ii)  $V_o = 3.75$  volts

[3]

(b) (i) digital outputs – two states – on /off

[2]

analogue input – input can vary from 0 – 5V because PIC has on board ADC capability.

[3]

(ii) 1.2volts = 51  
and 0.8volts = 34

[4]

(iii)

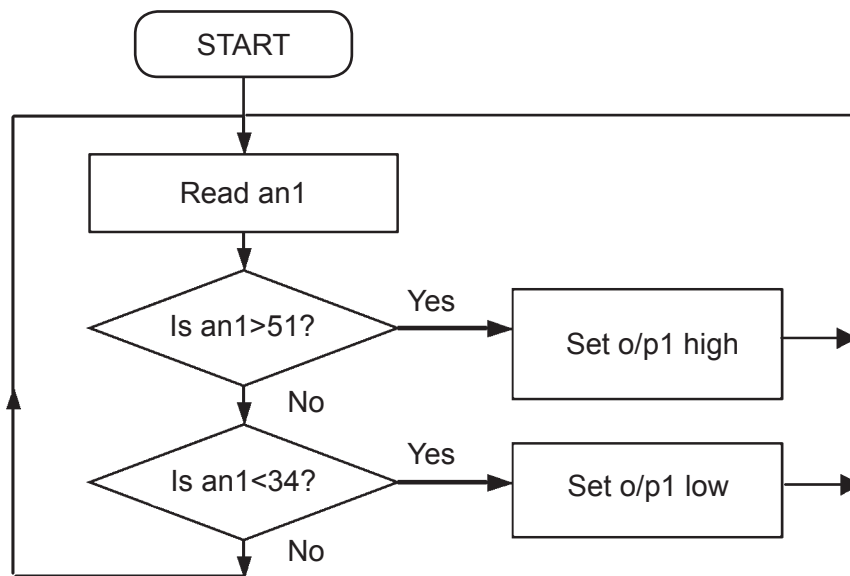

[8]

- (c) (i) Appropriate sketch and explanation to include the following  
 – When light reaches the base/collector junction through a transparent case the collector/emitter current is amplified.

[4]

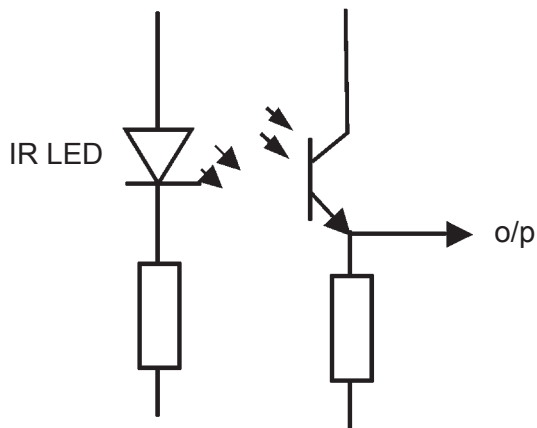

- (ii) 60 pulses per second

[3]

(II) + (iii)

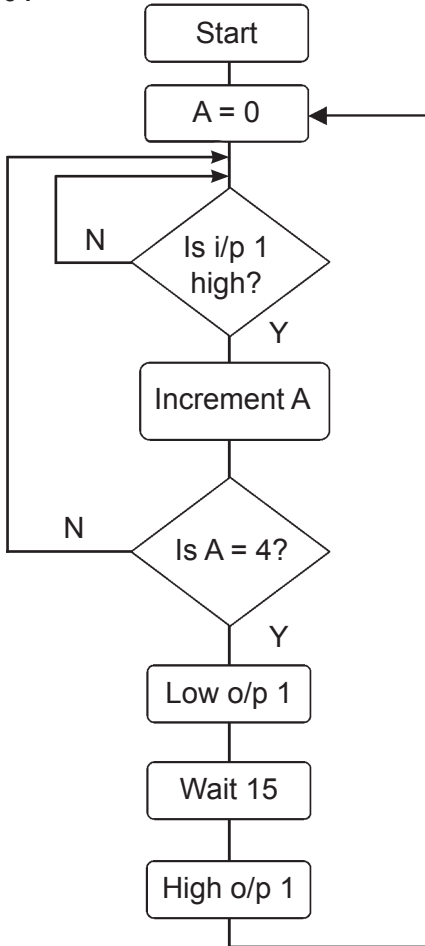
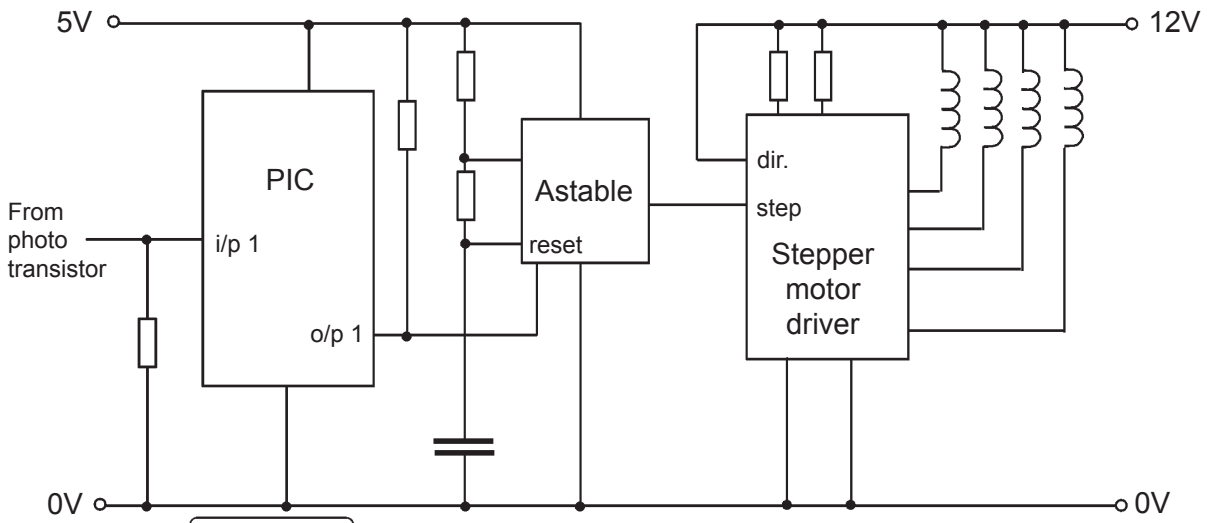

[10]

Total

80

Section B

3 (a) Fig 3(a) shows a linkage which forms part of a prototype manual compactor for recycled waste . A force is applied at F which enables the compactor plate to press on the waste.

(i) Briefly outline one way the mechanical advantage of the compactor could be increased.

**Ans** = Increase the length of the handle arm. [1]  
Or other suitable answer.

(ii) The compacted waste is stored in large bags for future transportation to a recycling plant. Design and draw a pulley block lifting system with a mechanical advantage of 6 which could be used to assist with the lifting of the large bags.

**Ans** = Suitable sketch of pulley based lifting system incorporating 6 strands between top and bottom pulley systems. [1]  
6 strands [1]  
6 pulleys [1]  
Viable system [1]

(iii) **Ans** = Use of a ratchet and pawl mechanism. Pawl preventing the pulley moving backwards. [5]

Quality of written communication

|   |     |
|---|-----|
| Poor selection and use of a writing form and style appropriate to the content. The script content is poorly organised and little use is made of appropriate technological vocabulary. The writing is barely legible and the spelling, grammar and punctuation is inaccurate.      | 0–2 |
| Good selection and use of a writing form and style appropriate to the content. The script content is organised and use is made of appropriate technological vocabulary. The writing is legible and the spelling, grammar and punctuation is accurate.                             | 3   |
| Very good selection and use of a writing form and style appropriate to the content. The script content is well organised and good use is made of appropriate technological vocabulary. The writing is clearly legible and the spelling, grammar and punctuation is very accurate. | 4   |

[4]

(b) Fig 3(b) shows part of a prototype industrial waste compactor. The waste falls down from the hopper and is crushed between the compacting wheels.

(i) Calculate the overall velocity ratio between A and N.

**Ans** = A – C = 60/30 = 2

D-E = 20/40 = 0.5 [1]

Wormwheel = 40

G-H 40/40 = 1 [1]

J – L = 60/60 = 1 [1]

M – N = 80/40 = 2 [1]

Tot VR = 2 × 0.5 × 40 × 1 × 1 × 2 = 80 [2]

(ii) Using an annotated sketch draw a sliding coupling arrangement at Z which would enable the motor to be detached easily for maintenance.

**Ans** = Annotated sketch showing male end [1]

Female end shown [1]

Viable system [3]

(iii) Calculate the speed of the compacting wheels if E rotates at 800 rev/min.

VR = 40 × 1 × 1 × 2 = 80 [6]

(iv) During testing waste occasionally got jammed in the hopper and it needed to be manually shaken to release it. Design and draw an automatic mechanical system to shake the hopper in the following way:

- Shake the hopper from side to side. This should have a total movement from left to right of 100mm.
- 60 shakes from left to right should take place each minute.
- The hopper should also move up and down 40 times each minute.
- Each time the hopper moves upwards it should reach a height of 20mm.

**Answer needs to complete the following:**

- Sketch showing how to shake the hopper from side to side. This should have a total movement from left to right of 100mm. [3]
- Sketch showing how 60 shakes from left to right should take place each minute. [2]
- Sketch showing how the hopper should also move up and down 40 times each minute. [2]
- Sketch showing how each time the hopper moves upwards it should reach a height of 20mm. [3]



4 (a) (i) Briefly state what is meant by the term interlocking when applied to pneumatic systems.  
**Ans** = It is the design of circuits so that each operation is dependent on the completion of the previous. [2]

(ii) The following sequence begins when the start switch is activated:

- Cylinder A outstrokes pushing cylinder B over base 1.
- Cylinder B outstrokes and the electromagnet secures the metal block.
- Cylinder B instrokes.
- Cylinder A instrokes to move cylinder B over the hopper.
- Cylinder C outstrokes to secure block Y.
- Cylinder D outstrokes to move block X to base 2.
- Cylinder D instrokes.
- Cylinder C instrokes.

On the proforma provided (answer No 4(a)(ii)) draw a suitable interlocking/cascade sequential pneumatic circuit to achieve the desired sequence.

- Ans = Method of activating cylinder A+ [2]
- Method of activating cylinder B+ [2]
- Method of activating cylinder B- [2]
- Method of activating cylinder A- [2]
- Method of activating cylinder C+ [2]
- Method of activating cylinder D+ [2]
- Method of activating cylinder D- [2]
- Method of activating cylinder C- [2]
- Group system [2]

**See sample answer**

(iii) Cylinder A has a stroke length of 110mm and produces a force during the outstroke of 600N. Assuming an efficiency of 95% calculate the work done on the outstroke.

- Ans = 600N produced at 95% eff
- $600 \times 100/95 = 632\text{N}$
- 632N produced at 100% [2]
- $WD = F \times L$
- $632 \times 0.11 = 69.5\text{J}$  [2]

(b) Design and draw a pneumatic system which will prevent the sequence from starting in the following situations:

- Base 1 does not have a block to be lifted.
- The hopper is full and can not accommodate a further one.

**Answer needs to include the following:**

- Method drawn outlining how the system detects if base 1 does not have a block. [4]
- Method drawn outlining how the system detects if the hopper is full. [4]

(c) **Fig 4 (b)** shows an incomplete pneumatic circuit incorporating a double acting cylinder controlled by five port valve X at another stage in the production line.

On the proforma provided (answer No 4(b)) complete the circuit to enable the double acting cylinder to outstroke with or without a time delay when required.

- |                       |     |
|-----------------------|-----|
| Ans = Additional 5Pv  | [2] |
| Shuttle valve         | [2] |
| Speed control         | [2] |
| Piping                | [2] |
| Electronic activation | [2] |

Or other suitable answer

**See sample answer**

Answer 4 (a) (iii)

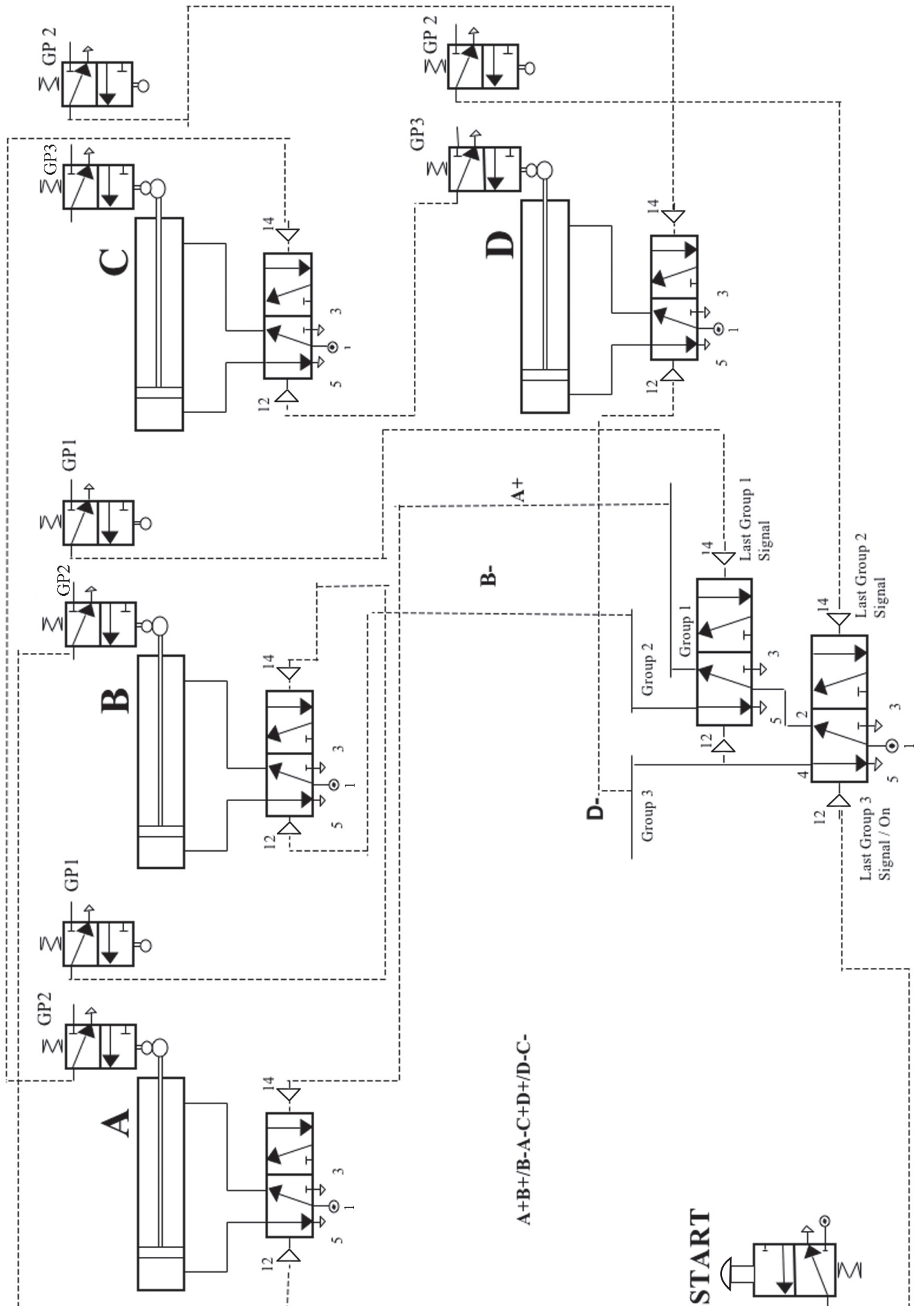

Answer 4 (c)

