



**GCE A level**

**1325/01**

**PHYSICS – PH5**

**Electromagnetism, Nuclei & Options**

**A.M. TUESDAY, 28 June 2016**

**1 hour 45 minutes plus your additional time allowance**

**Surname** \_\_\_\_\_

**Other Names** \_\_\_\_\_

**Centre Number** \_\_\_\_\_

**Candidate Number** 2 \_\_\_\_\_

## **ADDITIONAL MATERIALS**

**In addition to this paper, you will require a calculator, a CASE STUDY BOOKLET and a DATA BOOKLET.**

## **INSTRUCTIONS TO CANDIDATES**

**Use black ink or black ball-point pen or your usual method.**

**Write your name, centre number and candidate number in the spaces provided on the front cover.**

**Write your answers in the spaces provided in this booklet. If you run out of space, use the continuation pages at the back of the booklet, taking care to number the question(s) correctly.**

## **INFORMATION FOR CANDIDATES**

**This paper is in 3 sections, A, B, and C.**

**Section A: 60 marks. Answer ALL questions. You are advised to spend about 1 hour on this section.**

**Section B: 20 marks. The Case Study. Answer ALL questions. You are advised to spend about 20 minutes on this section.**

**Section C: Options; 20 marks. Answer ONE OPTION ONLY. You are advised to spend about 20 minutes on this section.**

**SECTION A**

**Answer ALL questions.**

**1. Polonium-211 decays to lead-207 with a decay constant ( $\lambda$ ) of  $1.343 \text{ s}^{-1}$ .**

**(a) Calculate the half-life of polonium-211. [2]**

---

---

---

---

---

---

---

---

---

---



1(c) Calculate the percentage of polonium-211 nuclei remaining after 2.4 s. [2]

---

---

---

---

---

---

---

---

---

---

- 1(d) Calculate the time taken for the number of polonium nuclei to decrease to **0.1%** of their initial number. [2]

---

---

---

---

---

---

---

---

---

---

- 1(e) Explain why  $4.22 \times 10^{-11}$  kg of polonium-211 could be highly dangerous even though it emits alpha particles which cannot penetrate human skin. [2]

---

---

---

---

---

---

---

---

---

---





mass of  ${}^{16}_8\text{O} = 15.9905\text{ u}$ ,      mass of  ${}^4_2\text{He} = 4.0015\text{ u}$





---

---

---

---

---

2(c) Explain without calculation, whether the total binding energy of  ${}_{14}^{28}\text{Si}$  and  ${}_{2}^{4}\text{He}$  is greater or less than that of two  ${}_{8}^{16}\text{O}$  nuclei. [3]

---

---

---

---

---

---

---

---

---

---

---

---

---

2(d) The following nuclear reaction would release considerably more energy but cannot occur.

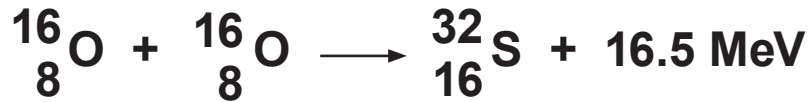

Explain why this is impossible in terms of SIMPLE CONSERVATION LAWS. (Hint: consider the following set up.) [3]

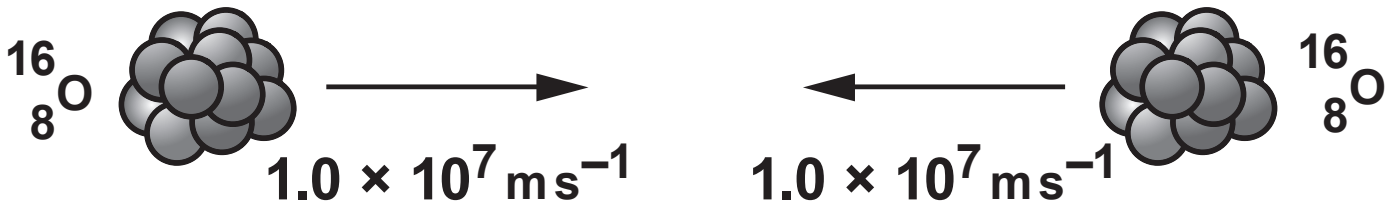

---



---



---



---



---



---



---



---



---



---



---

- 3(a) Calculate the capacitance of the combination of capacitors shown. [3]

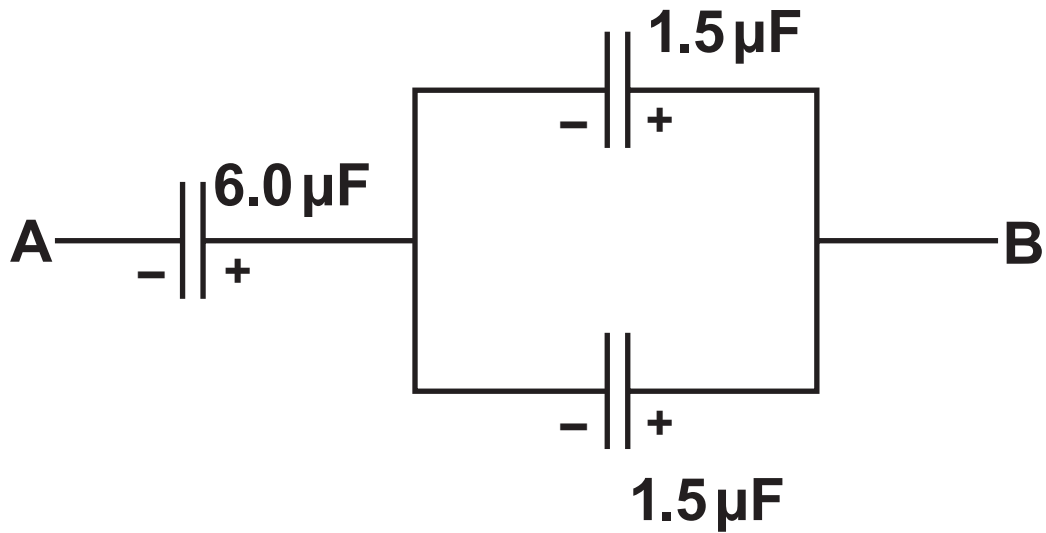

---

---

---

---

---

---

---

---

---

---

---

**3(b) Explain why the  $6.0\ \mu\text{F}$  capacitor stores the same amount of energy as one of the  $1.5\ \mu\text{F}$  capacitors.**

**[2]**

---

---

---

---

---

---

---

---

---

---

---

---

---









4(b) A strong magnet drops vertically through a flat coil.

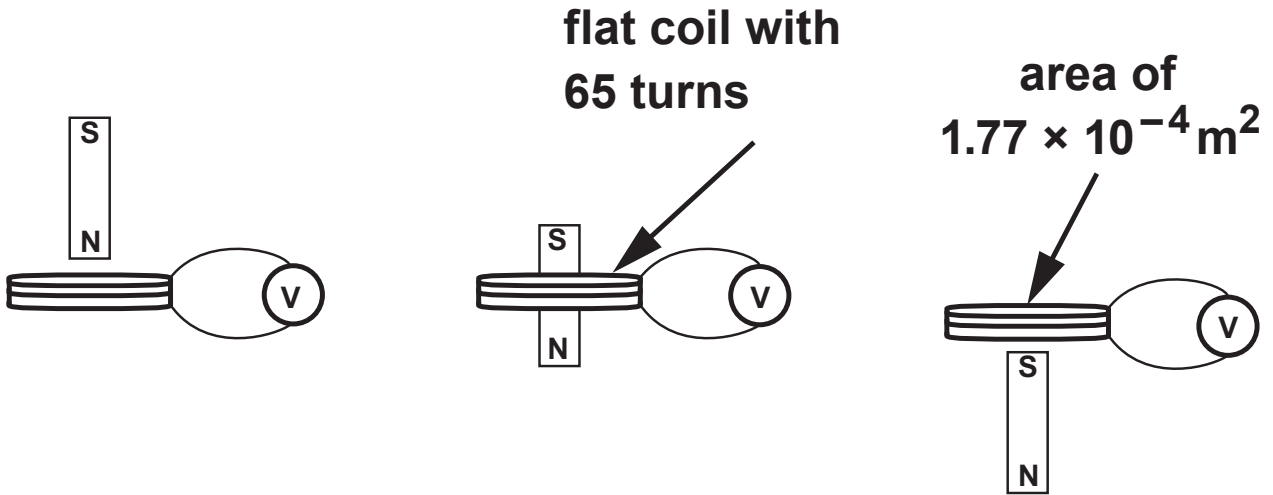

(i) Use the laws of Faraday and Lenz to explain why the measured emf varies as shown in the graph opposite. [3]

---



---



---



---



---



---



---



---



---



---



---



---

The emf induced in the coil is recorded using a voltmeter.

Induced emf / mV

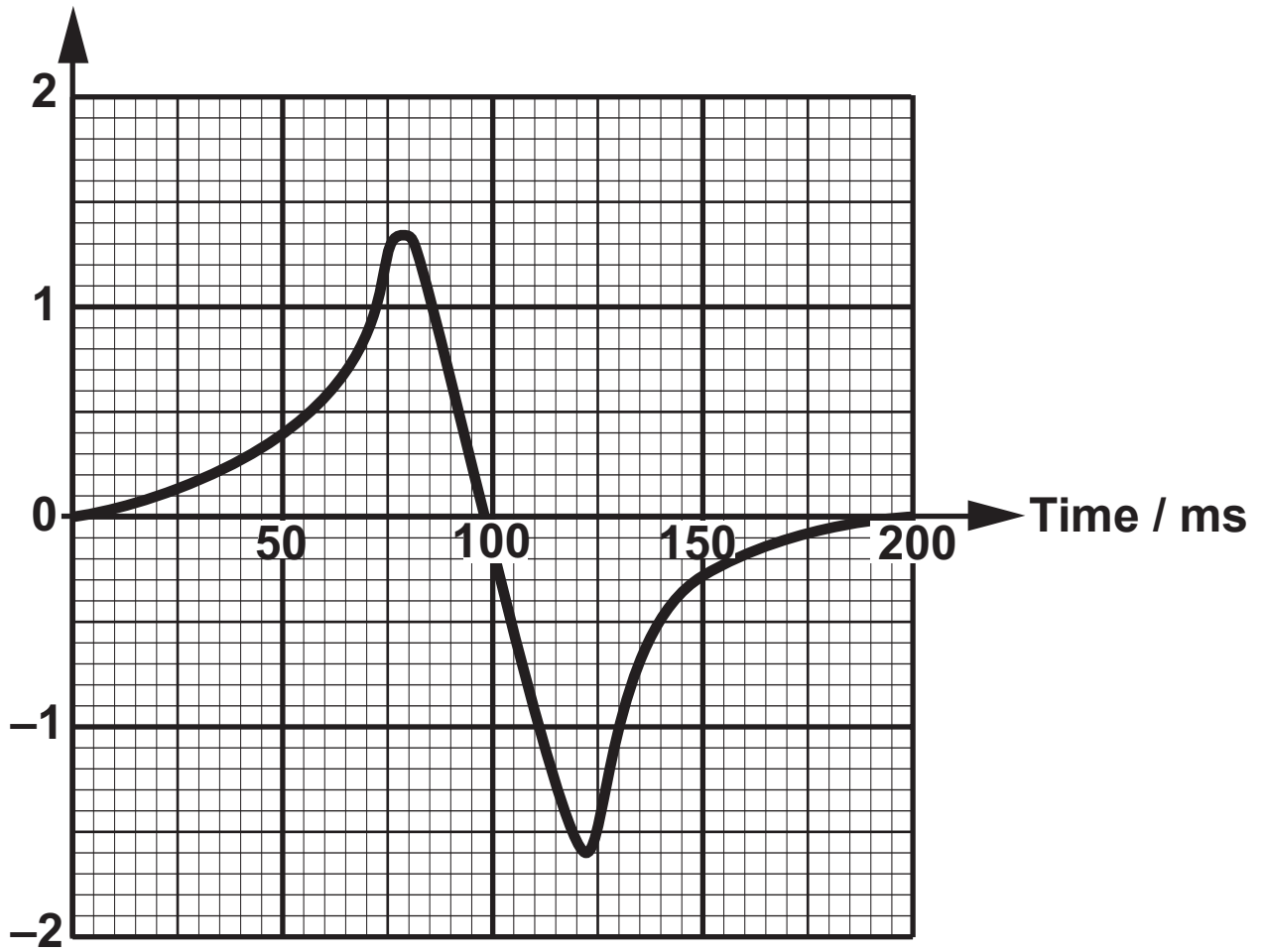



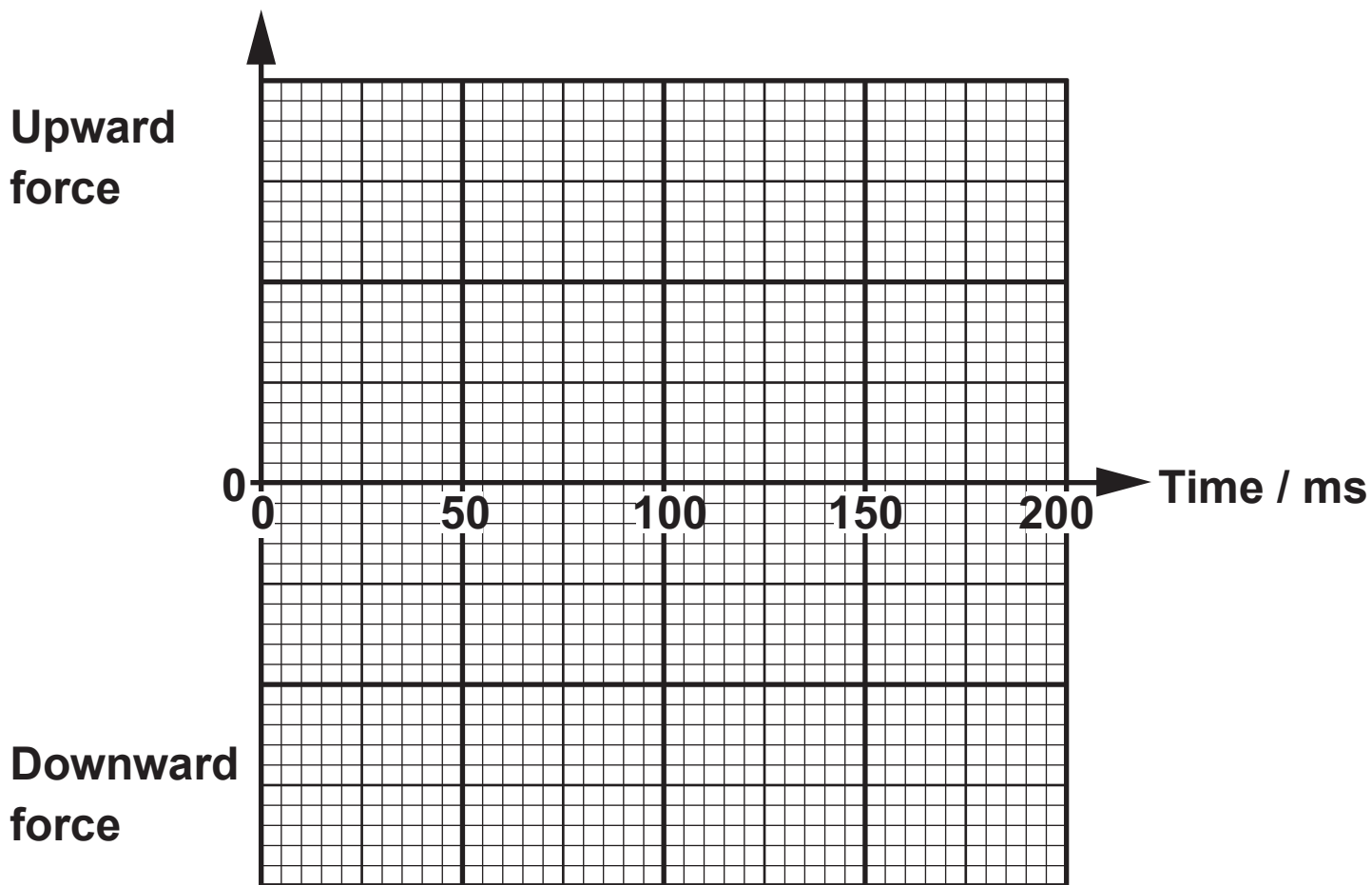

**5(a) An electron-positron pair is produced by a photon of energy  $1.04 \text{ MeV}$ .**

**(i) Show that the energy required to produce an electron-positron pair is  $1.02 \text{ MeV}$ . [2]**

---

---

---

---

---

---

---

---

---

---



- 5(a) (ii) State what happens to the remaining  $0.02 \text{ MeV}$  of the photon energy in this electron-positron pair production. [1]**

---

---

---

---

- 5(b) Point **P** is half way between two long wires each carrying a current of **19 A** and **18.0 cm** away from a third long wire carrying a current of **50 A**. Show that the resultant magnetic flux density due to the **THREE** long wires at point **P** is approximately  $6 \times 10^{-5} \text{ T}$  and **STATE ITS** direction. [4]

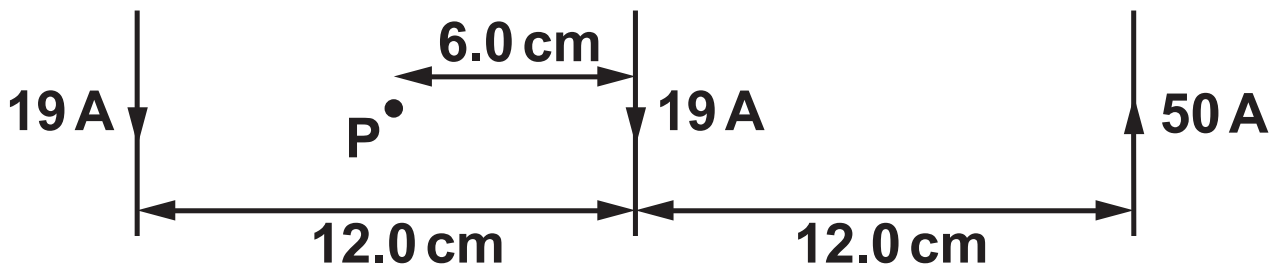

---

---

---

---

---

---

---

---

---

---

---

---

---

---

---

---

---

---

---

---

---

---

---

---



- 5(c) (ii) Calculate the radius of motion of a positron moving perpendicularly to a uniform magnetic flux density ( $B$ ) of  $6.0 \times 10^{-5} \text{ T}$  when the speed of the positron is  $6.0 \times 10^7 \text{ m s}^{-1}$ . [1]

---

---

---

---

---

---

---

**5(c) (iii) Hence, explain why a positron produced at point P initially moving to the left will not travel with uniform circular motion. [2]**

---

---

---

---

---

---

---

---

---

---



**6(b) What does the author mean when it is stated that ‘... PARTICLES WERE AT RELATIVISTIC SPEEDS’? (paragraph 5). [1]**

---

---

---

---

**(c) Explain briefly why ‘BARYOGENESIS, A REACTION THAT WE KNOW LITTLE ABOUT’ is required to explain the current content of the universe (paragraph 5). [2]**

---

---

---

---

---

---

---

---

---

---



---

---

---

---

**6(d) Explain why the production of electron-positron pairs stops at a later time than proton-antiproton pairs (paragraph 6). [2]**

---

---

---

---

---

---

---

---

---

---

**6(e) Explain briefly what the term ‘BIG BANG NUCLEOSYNTHESIS’ means and what enabled this process to take place (paragraph 7). [2]**

---

---

---

---

---

---

---

---

**(f) In your own words, explain briefly why the universe became transparent after 380 000 years (paragraph 8). [3]**

---

---

---

---

---

---

---

---

---

---

---

---



**6(h) Use EQUATION 3 to confirm that the critical density of the universe corresponds to around 5 hydrogen atoms per cubic metre (paragraphs 10-12). [2]**

---

---

---

---

---

---

---

---

---

---

**6(i) Use FIGURE 2 to confirm that the mean temperature of the universe is approximately 2.725 K. [2]**

---

---

---

---

---

---

---

---

---

---

---

---

---

---

---

**SECTION C: OPTIONAL TOPICS**

**Option A: FURTHER ELECTROMAGNETISM  
AND ALTERNATING CURRENTS**

**Option B: REVOLUTIONS IN PHYSICS –  
ELECTROMAGNETISM AND  
SPACE-TIME**

**Option C: MATERIALS**

**Option D: BIOLOGICAL MEASUREMENT  
AND MEDICAL IMAGING**

**Option E: ENERGY MATTERS**

**Answer the question on ONE TOPIC ONLY.**

**Place a tick (✓) in one of the boxes above, to show which topic you are answering.**

**YOU ARE ADVISED TO SPEND ABOUT 20 MINUTES ON THIS SECTION.**



**7(a) (ii) Suggest why transformers employing superconducting coils might be beneficial even though there is considerable cost in liquid nitrogen for cooling. [1]**

---

---

---

---

---

---

---





variable frequency a.c. supply

$V_{\text{rms}} = 230 \text{ V}$

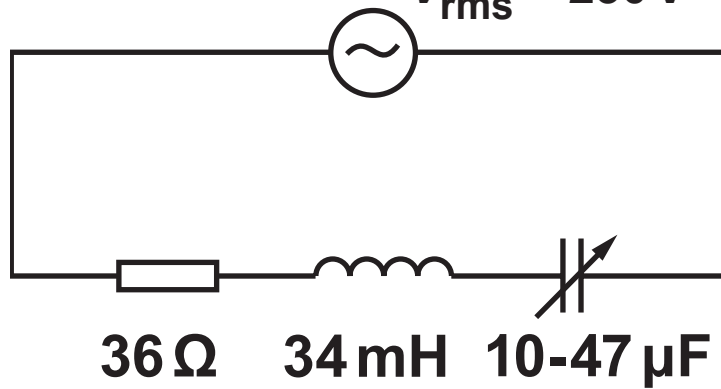

7(b) (ii) Explain what happens to the  $Q$  factor of the circuit when the capacitance is increased.

[2]

---

---

---

---

---

---

---

---

---

---





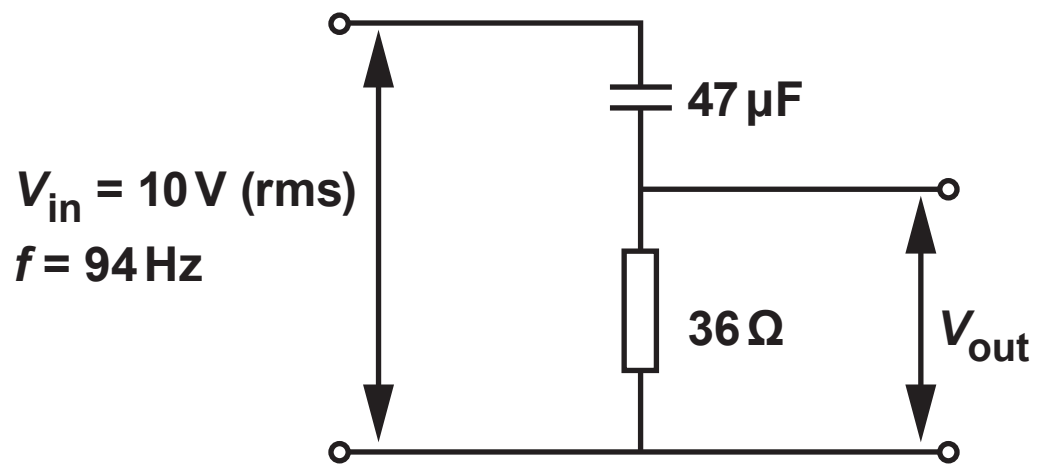



## Option B: Revolutions in Physics – Electromagnetism and Space-Time

8(a) In the following passage, Thomas Young explained the positions of the fringes formed when light from a single source is diffracted by two closely spaced apertures (at equal distances from the source) and the diffracted light overlaps.

“The brighter stripes on each side [of the central bright stripe] are at such distances that the light coming to them from the apertures must have passed through a longer space than that which comes from the other, by an interval which is equal to the breadth of one, two, three or more of the supposed undulations, while the intervening dark spaces correspond to a difference of half a supposed undulation, of one and a half, or two and a half or more.”

(i) What is meant by ‘THE BREADTH OF AN UNDULATION’? [1]

---

---

---

---



- 8(a) (ii) Put Young's condition for the THIRD DARK fringe (from the centre) into the form of an equation, giving a simple labelled diagram to help you explain the meanings of terms in the equation. [3]**

---

---

---

---

---

---

---

---

---

---

**8(b) (i) Describe briefly one discovery which Ampère made by experiment. [2]**

---

---

---

---

---

---

---

**(ii) What did Ampère believe was occurring inside a magnet to give rise to its magnetic properties? [2]**

---

---

---

---

---

---

---

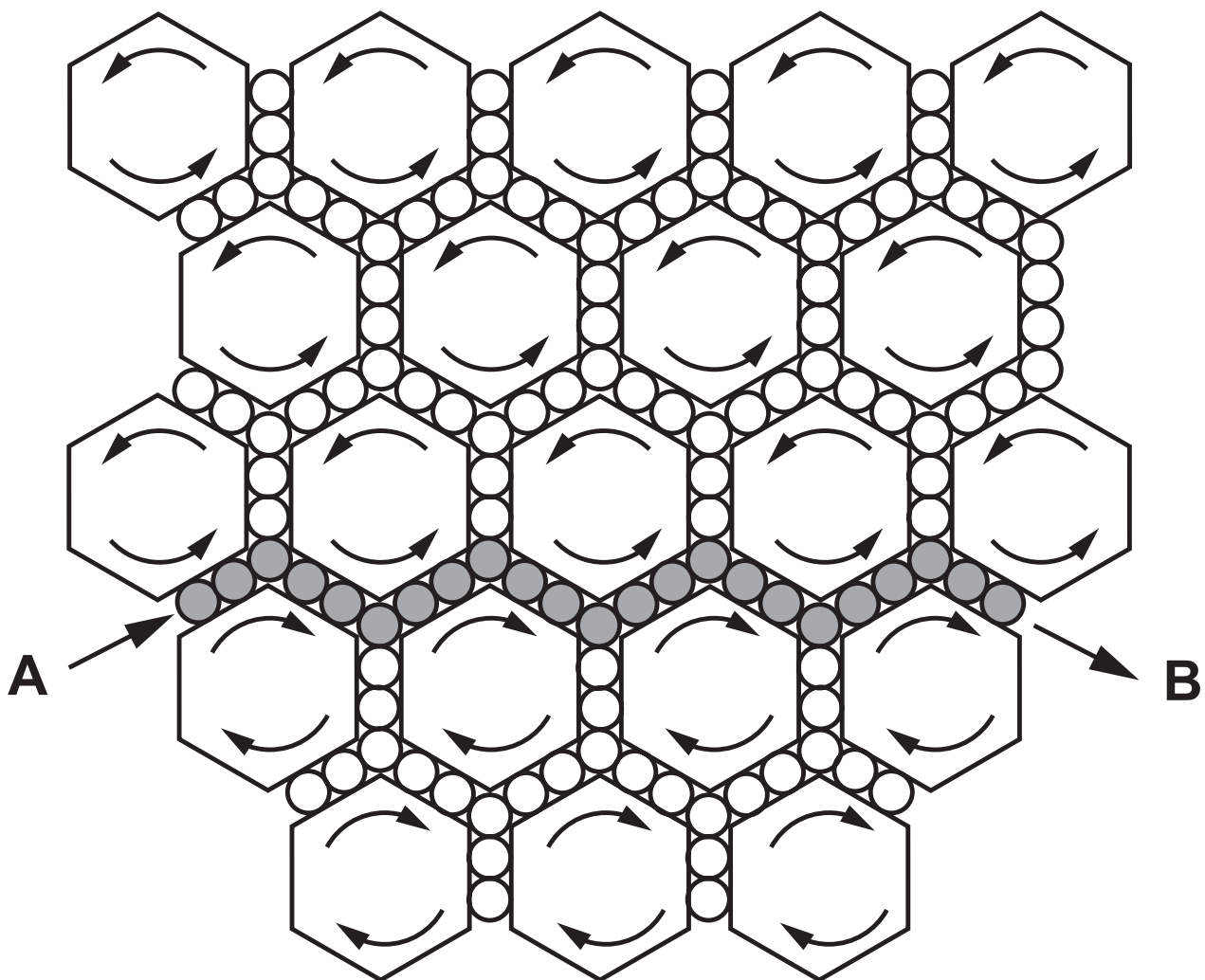



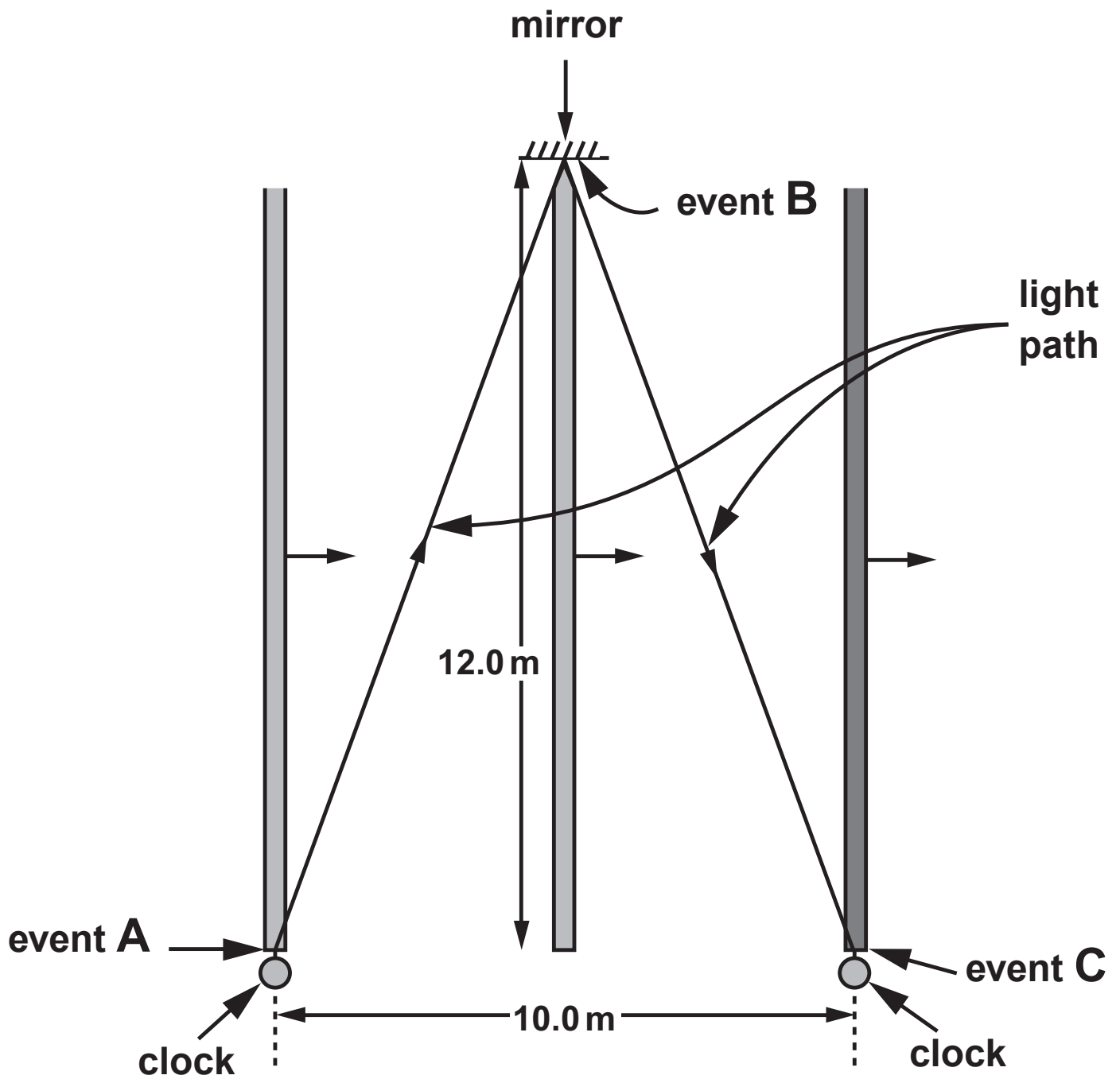

**8(d)** In a thought-experiment shown on the opposite page, a rod of length **12.0 m** moves at a constant velocity through a laboratory, in a direction at right angles to its own length. The rod carries a mirror at one end. A flash of light is sent (event **A**) from the other end, reflects (event **B**) off the mirror and arrives back (event **C**) at the other end. In the laboratory frame of reference the events occur at the places shown.

- (i) Calculate the total length of the light path and **HENCE** show clearly that the time between events **A** and **C**, as measured by synchronised clocks (with suitable sensors), placed as shown in the laboratory, is approximately **87 ns**. Give your answer to **3 significant figures**. [3]

---

---

---

---

---

---

---

---

---

---

---

---

---

---

---

**8(d) (ii) By considering the total length of the light path in the rod's frame (the frame of reference in which the rod is stationary), calculate the time between events **A** and **C** in the rod's frame. [1]**

---

---

---

---

---

---

**8(d) (iii) State the difference between a PROPER and an IMPROPER time, referring to parts (d)(i) and (ii). [2]**

---

---

---

---

---

---

---

---

---

---





## Option C: Materials

**9(a) A specimen of rubber is gradually loaded and then unloaded. A stress-strain diagram for the specimen is shown opposite.**

- (i) State the feature of the graph which confirms that the rubber was deformed elastically. [1]**

---

---

---

---

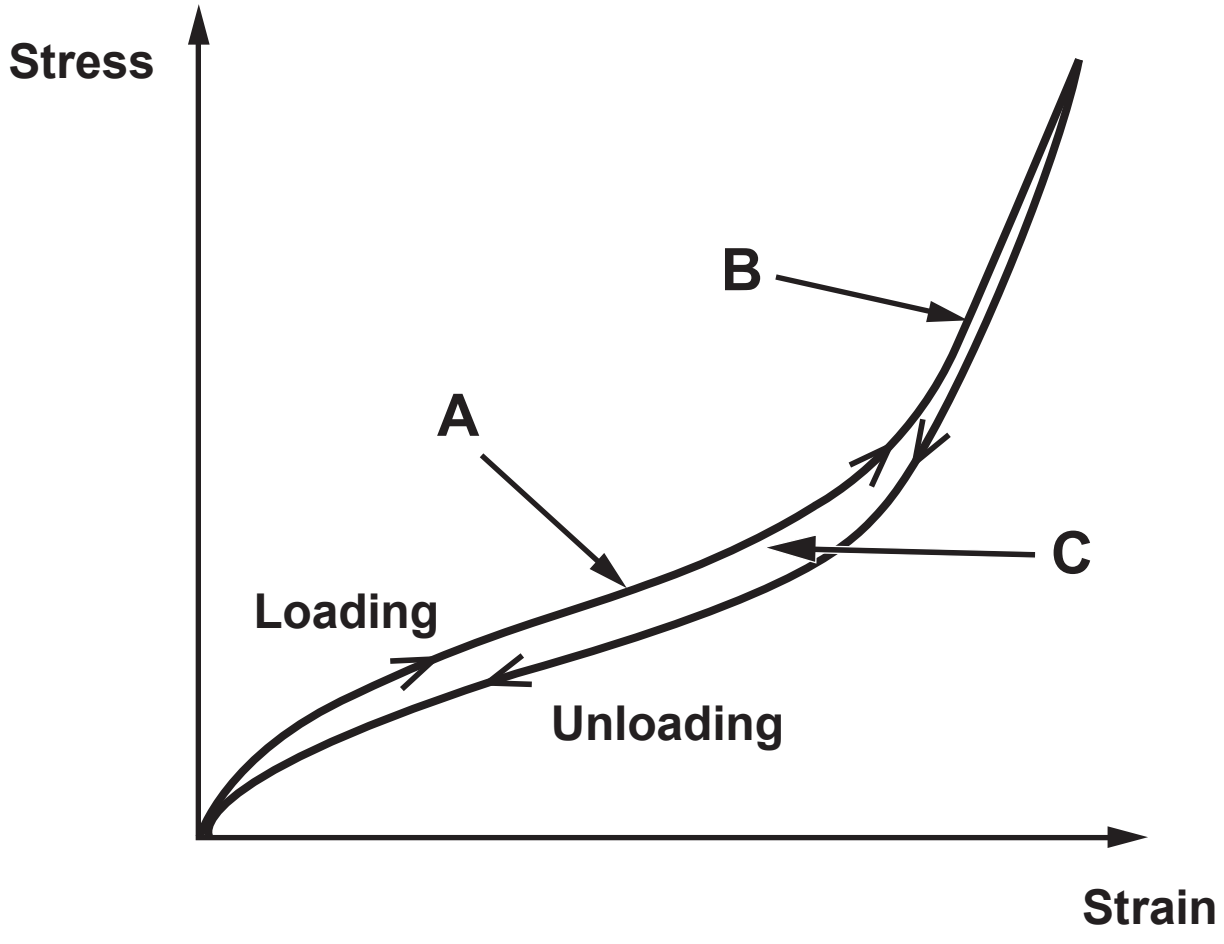





**9(a) (iv) With reference to your answer to part (a) (iii), explain why it is inadvisable to drive cars with tyres which are under-inflated, that is, with less than the recommended air pressure. [1]**

---

---

---

---

---

---

---

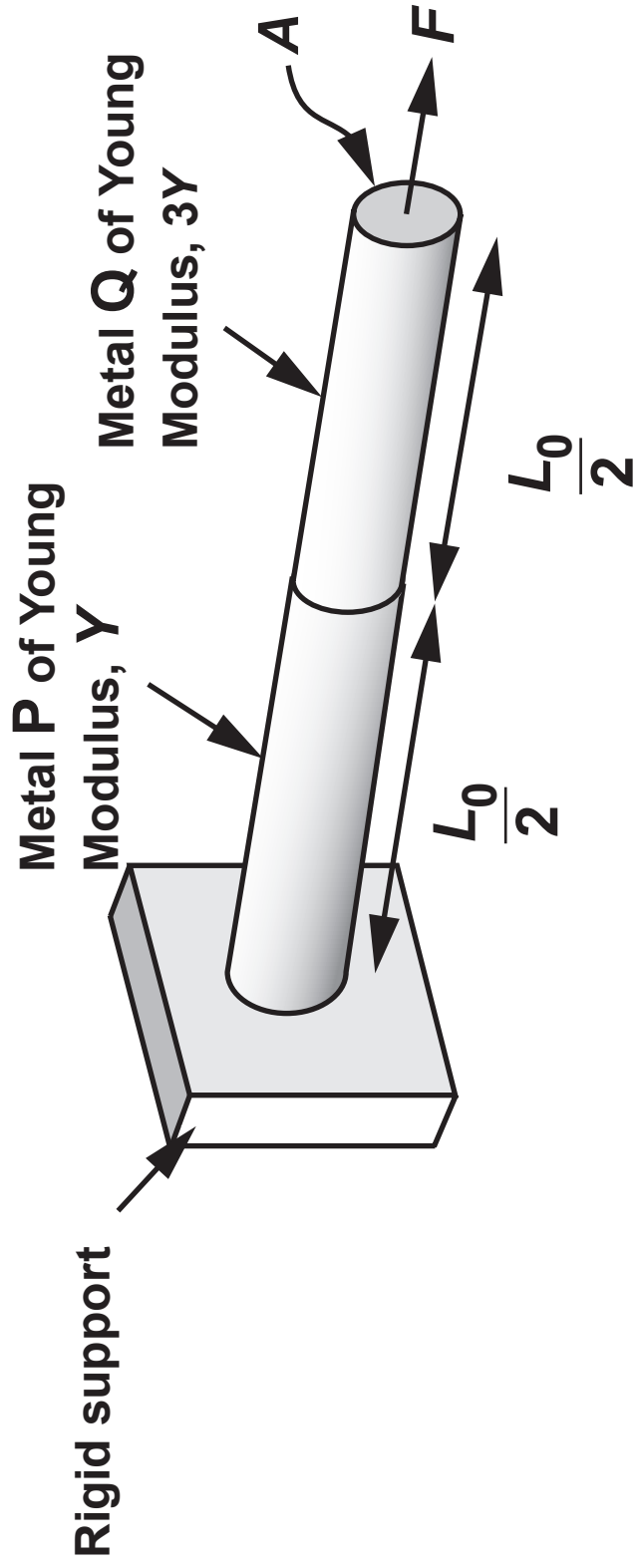

9(b) The bar in the figure below is made from two different metals, **P** and **Q**, of equal length  $\frac{L_0}{2}$  and cross-sectional area, **A**. The metals are welded securely to each other and to the rigid support.

- (i) By considering the total extension of both metals under the action of a common force, **F**, show in clear steps that the energy, **W**, stored in the combination can be given by: [4]

$$W = \frac{F^2 L_0}{3AY}$$

---

---

---

---

---

---

---

---

---

---





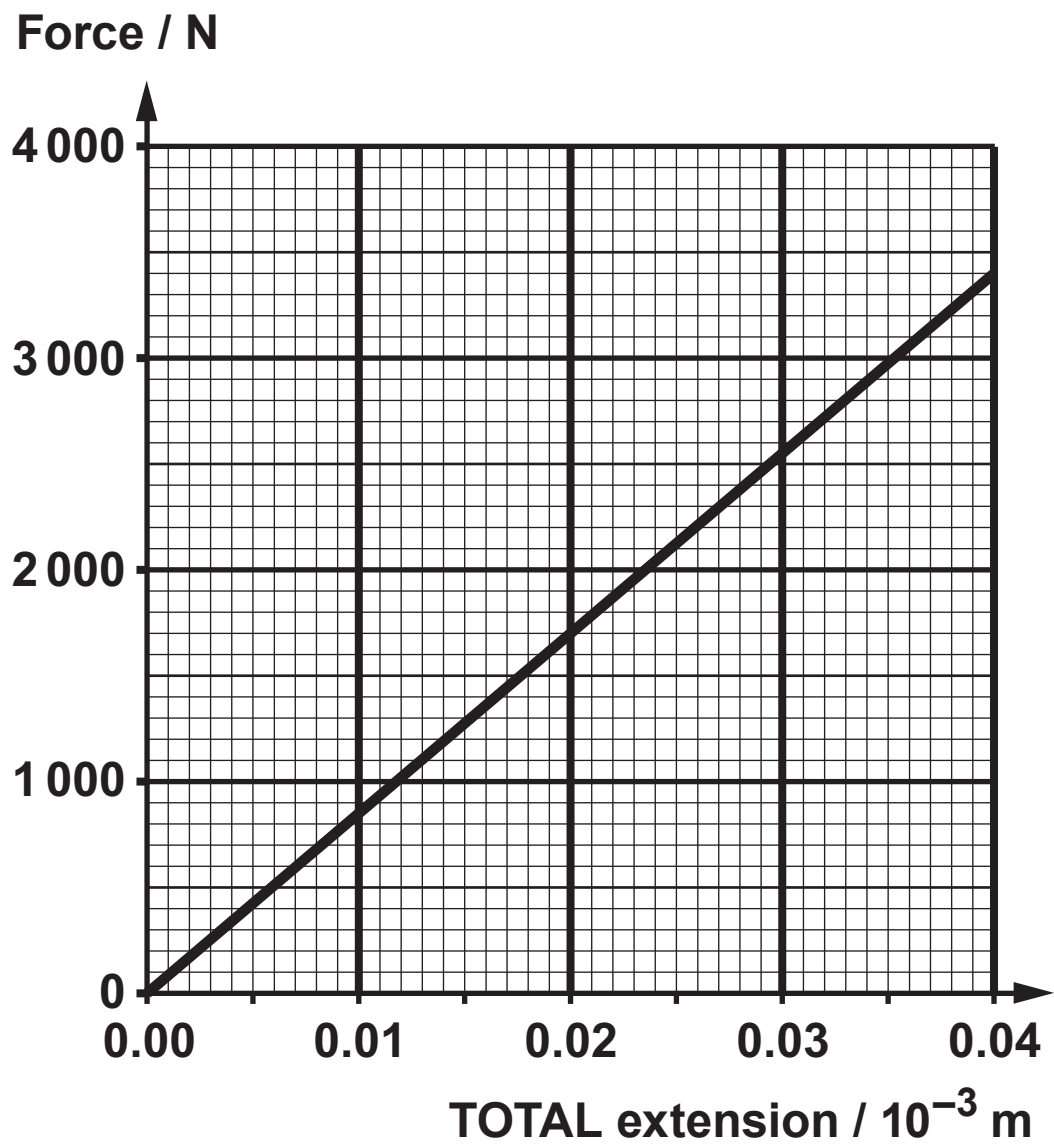

**9(b) (ii) A force-extension graph for the combination is shown opposite.**

**Use the graph to determine the energy stored in the combination when the applied force = 2 800 N. [2]**

---

---

---

---

---

---

---

---

---

---





Relative intensity

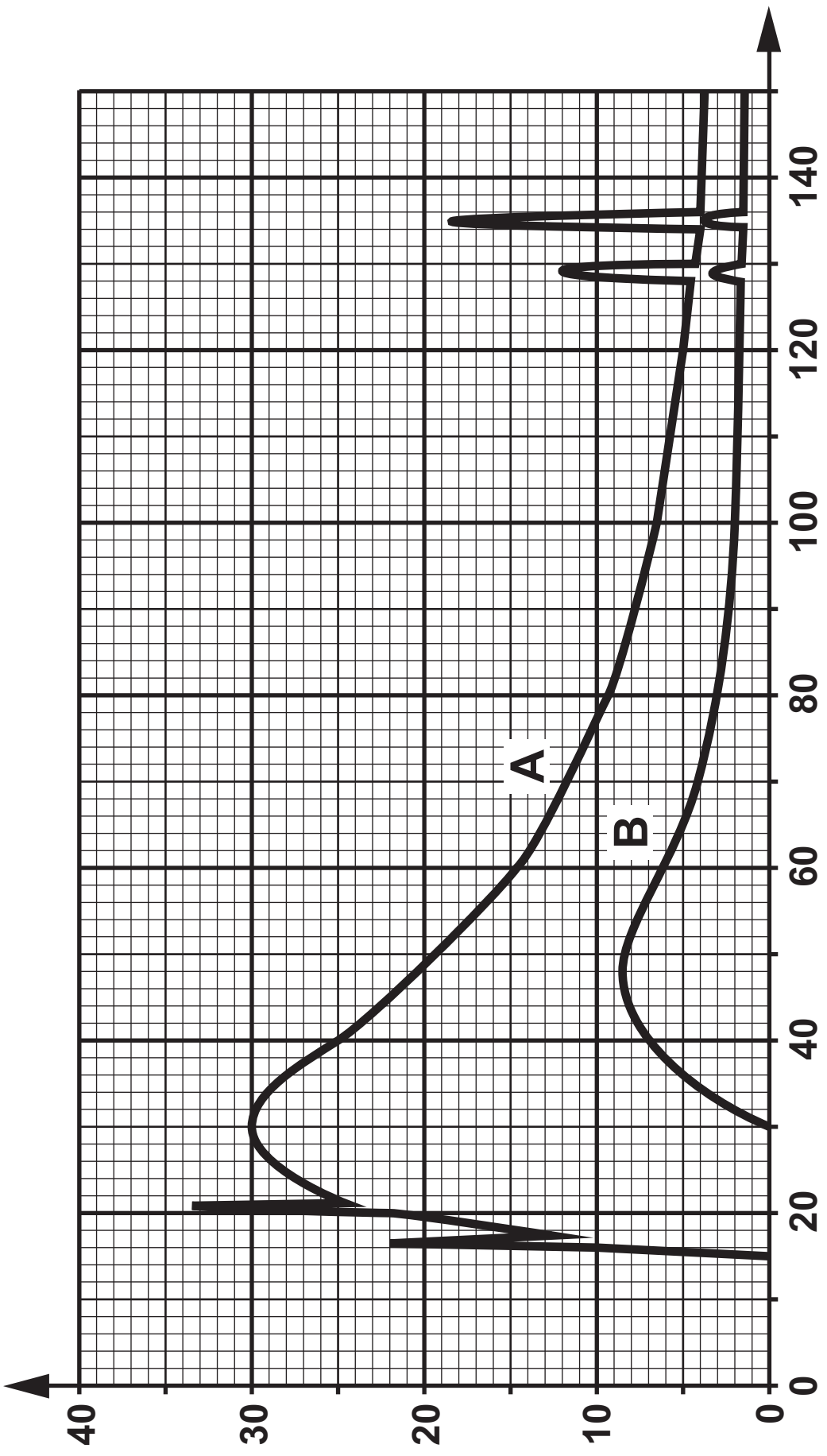

Wavelength /  $10^{-12}$  m

## Option D: Biological Measurement and Medical Imaging

10. The diagram opposite shows two X-ray spectra produced by X-ray tubes.

(a) (i) Without calculation compare the accelerating voltages used to produce the two spectra, **A** and **B**. Explain your reasoning. [2]

---

---

---

---

---

---

---

---

---

---

10(a) (ii) The target used was of the same material in the two cases. State how the graphs support this statement. [1]

---

---

---

---

(iii) Spectrum **A** was produced using an accelerating voltage of **84 kV**. Use this to calculate a value for the Planck constant,  $h$  (show your working). [2]

---

---

---

---

---

---

---

---

---

---



---

---

---

---

**10(a) (iv) Calculate the accelerating voltage used to produce spectrum B. [2]**

---

---

---

---

---

---

---

---

---

---

**10(b) Both MRI and CT scans can be used in diagnostic medicine. Give ONE advantage and ONE disadvantage (other than cost) of using MRI scans over CT scans. [2]**

---

---

---

---

---

---

---

---

---

---



- 10(c) (ii) The wavelength of ultrasound used is **0.40 mm** and it travels through the blood at **1 200 m s<sup>-1</sup>**. If the wavelength shift of the received ultrasound is **0.60  $\mu\text{m}$** , calculate the speed of flow of the blood. [2]

---

---

---

---

---

---

---

---

---

---

**10(d) An ECG recorder is used to check a patient's heart. Sketch the expected ECG trace for a healthy heart. Both axes should be labelled. [2]**





---

---

---





**11(a) (ii) Explain briefly why the Dinorwig station is extremely useful even though its mean output power is negative. [1]**

---

---

---

---

---

---

---



---

---

---

---

---

---

**11(b) (ii)      The height of the Itaipu dam is 118 m and its mean output power is 11 GW. Determine the mass of water that passes through the Itaipu hydroelectric system daily, stating any assumption that you make. [4]**

---

---

---

---

---

---

---

---

---

---

---

---

---

---

---

---

---

---

---

---

11(c) (i) Calculate a value for the Solar Constant from the following data. [3]

Temperature of the Sun = 5 780 K,  
Radius of the Sun =  $6.96 \times 10^8$  m,  
Distance from the Earth to the Sun =  $1.50 \times 10^{11}$  m.

---

---

---

---

---

---

---

---

---

---

---



**11(c) (iii)      The cost per square metre of solar panels is around £200 but they have a guaranteed lifetime of 25 years. Compare the cost of producing electricity using solar panels with the normal cost of producing electricity (£40-60 per MWh). [4]**

---

---

---

---

---

---

---

---

---

---

---

---

---

---

---

---

---

---

---

---

---

---

---

---

---

---









