



GCE A level

1325/01

PHYSICS – PH5

ASSESSMENT UNIT

Electromagnetism, Nuclei & Options

A.M. THURSDAY, 19 June 2014

1 hour 45 minutes plus your additional time allowance

Surname _____

Other Names _____

Centre Number _____

Candidate Number 2 _____

ADDITIONAL MATERIALS

In addition to this paper, you will require a calculator, a CASE STUDY BOOKLET and a DATA BOOKLET.

INSTRUCTIONS TO CANDIDATES

Use black ink, black ball-point pen or your usual method.

Write your name, centre number and candidate number in the spaces provided on the front cover.

Write your answers in the spaces provided in this booklet. If you run out of space, use the continuation pages at the back of the booklet, taking care to number the question(s) correctly.

INFORMATION FOR CANDIDATES

This paper is in 3 sections, A, B, and C.

Section A: 60 marks. Answer ALL questions. You are advised to spend about 1 hour (plus your additional time allowance) on this section.

Section B: 20 marks. The Case Study. Answer ALL questions. You are advised to spend about 20 minutes (plus your additional time allowance) on this section.

Section C: Options; 20 marks. Answer ONE OPTION ONLY. You are advised to spend about 20 minutes (plus your additional time allowance) on this section.

SECTION A

Answer ALL questions.

- 1(a) Carbon fuses with helium to produce oxygen and energy.



The masses of the helium and carbon nuclei are 4.0015 u and 11.9967 u respectively.

- (i) Calculate the binding energy PER NUCLEON of the carbon nucleus

(1 u = 931 MeV, $m_{\text{proton}} = 1.0073 \text{ u}$, $m_{\text{neutron}} = 1.0087 \text{ u}$).

[3]

1(a) (ii) Use the energy released in the reaction on page 4 to calculate the mass of the oxygen-16 nucleus to 6 significant figures. (1 u = 931 MeV.) [4]

1(b) It is important to choose suitable materials inside a nuclear fission reactor to act as control rods, moderator and coolant. Name ONE IMPORTANT PROPERTY OF THE MATERIALS used for the:

(i) control rods; [1]

(ii) moderator; [1]

(iii) coolant. [1]

2(c) When radon gas is kept in a lead lined container for 3.8 days, the number of radon gas particles halves. However, the activity inside the container is considerably higher than half the original activity. Suggest a reason why. [1]

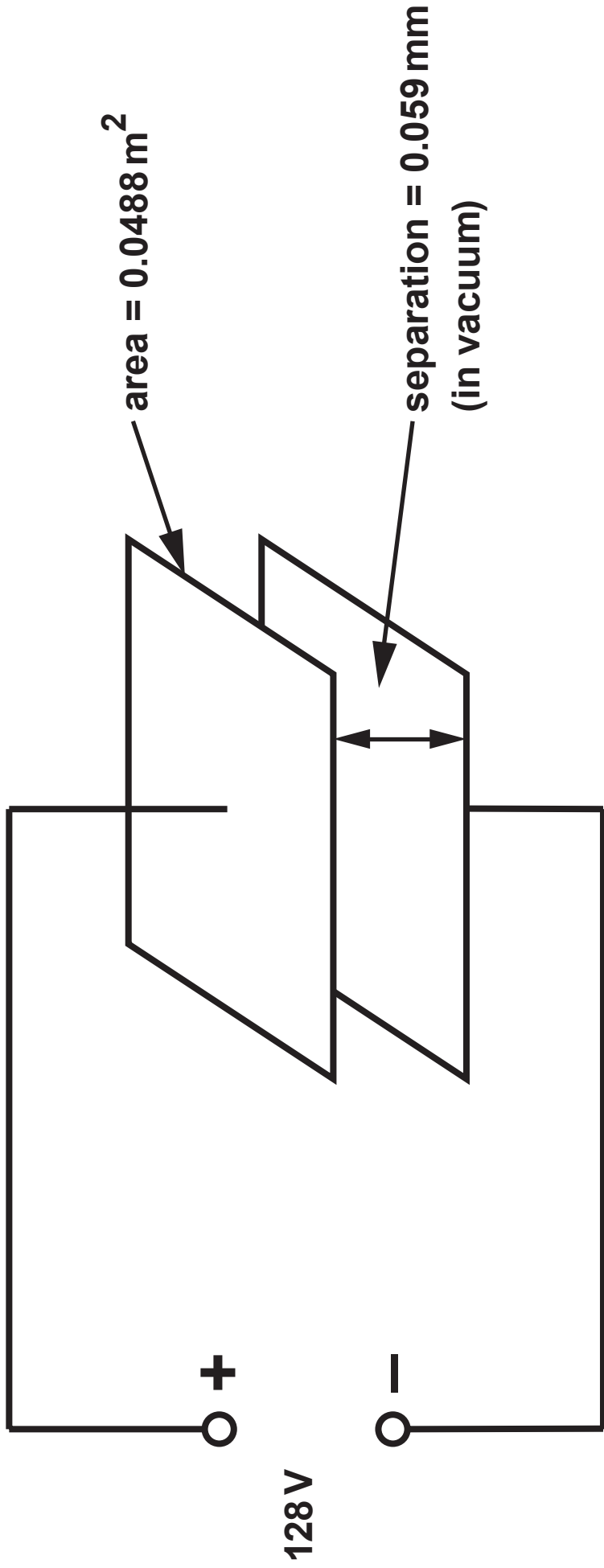

3(a) (ii) Use (a)(i) to calculate the energy stored by the capacitor. [1]

(iii) Calculate the electric field strength (E) between the plates. [2]

3(b) (ii) Explain how energy is conserved in this case. [2]

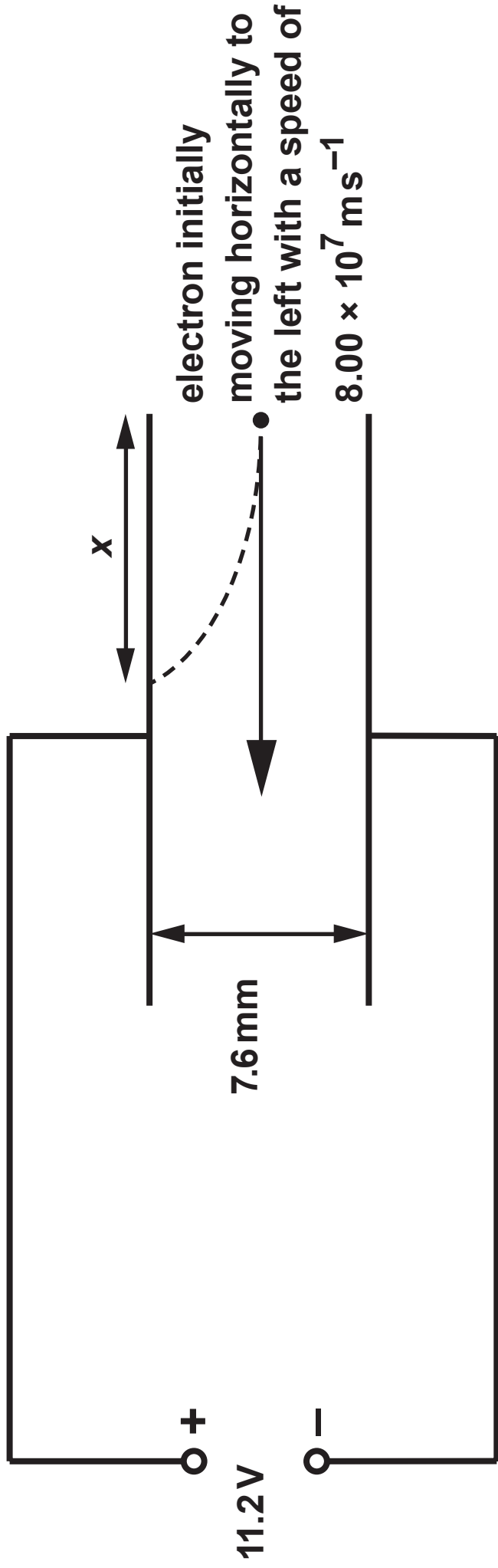

electron initially

moving horizontally to
the left with a speed of

$$8.00 \times 10^7 \text{ ms}^{-1}$$

x

7.6 mm

+

11.2V

-

5(b) (i) Explain why the HORIZONTAL SPEED of the electron remains constant. [1]

(ii) Explain why the vertical ACCELERATION of the electron is constant. [1]

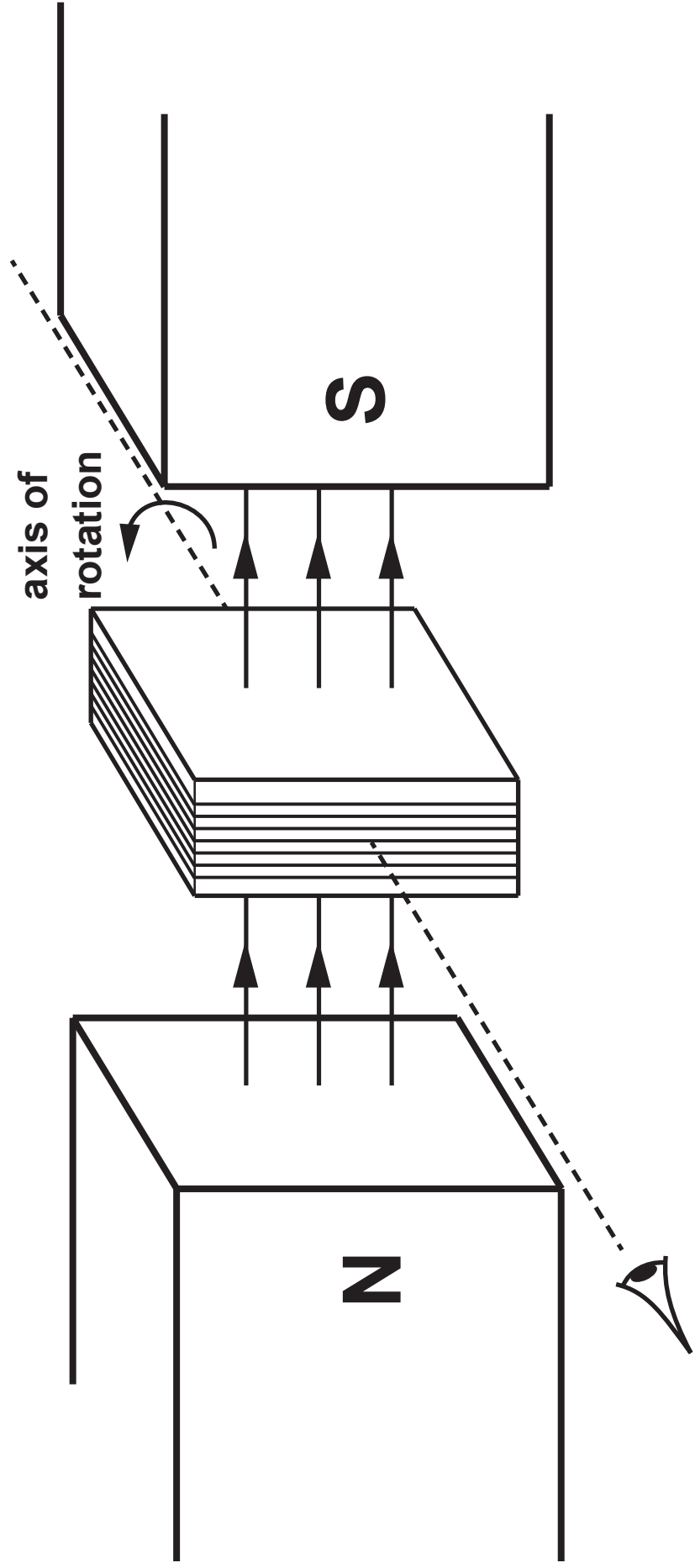

6. A rectangular coil rotates at a constant angular velocity within a uniform magnetic field. The coil has 42 turns and area $22.0 \text{ cm} \times 15.0 \text{ cm}$. The diagram opposite is a simplified 3D diagram of the coil when the magnetic field is perpendicular to the coil.

The second diagram is a 2D representation of the coil looking along the axis of rotation.

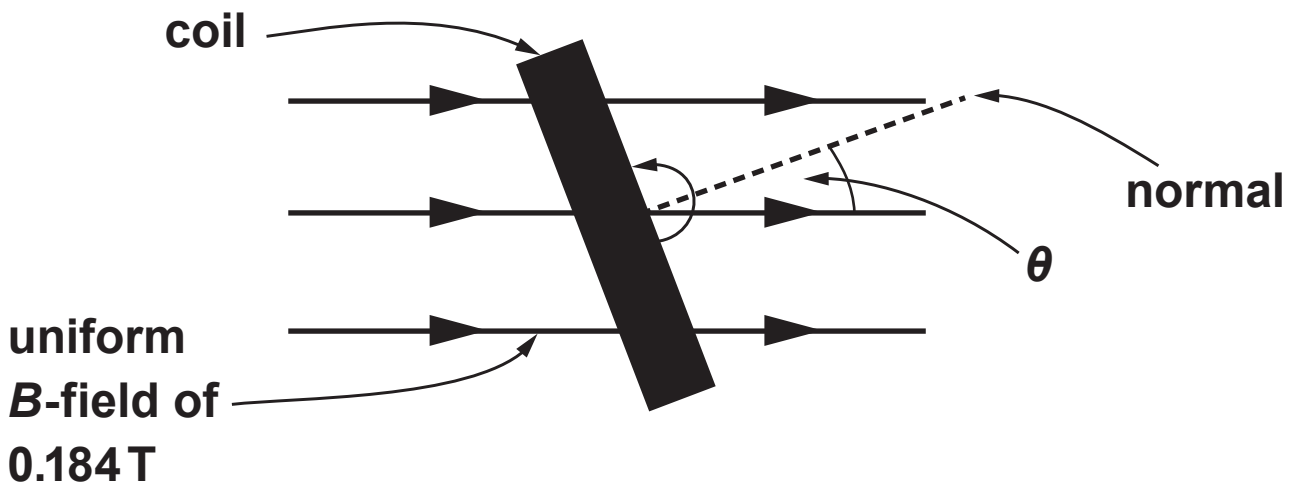

- 6(a) (i) Calculate the flux LINKAGE of the coil for the angles $\theta = -10^\circ$ and $\theta = +10^\circ$. [2]

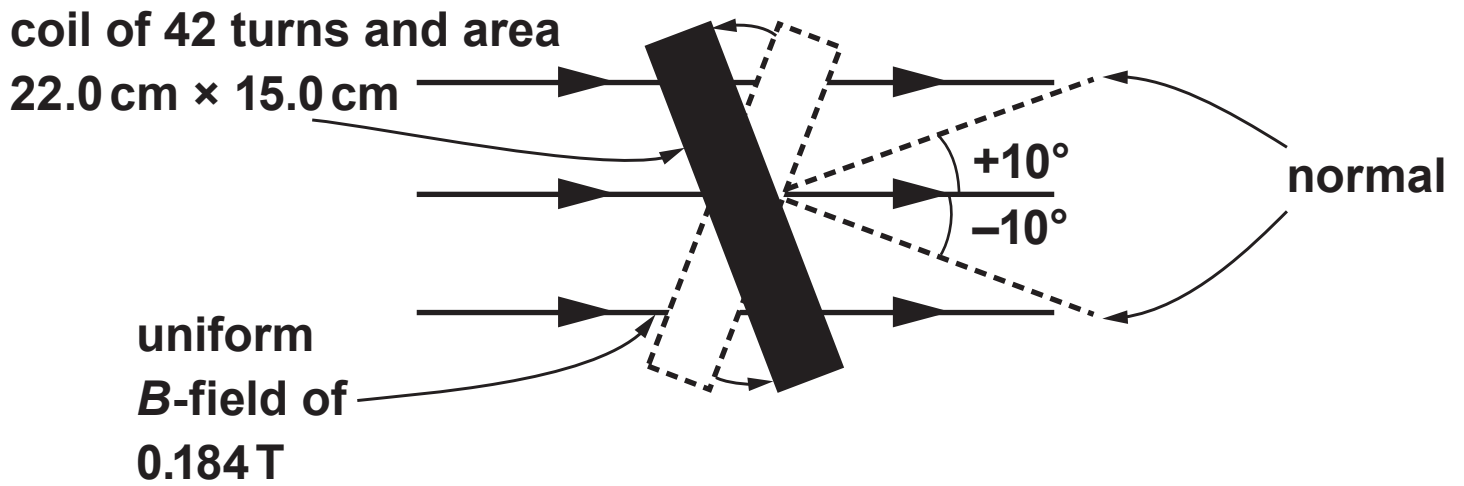

- 6(a) (ii) Explain why the mean induced emf is zero as the coil moves between $\theta = -10^\circ$ and $\theta = +10^\circ$. [1]

- 6(b) Calculate the mean induced emf in the coil when the angle θ changes from 80° to 100° if the period of rotation of the coil is 0.100 s. [4]

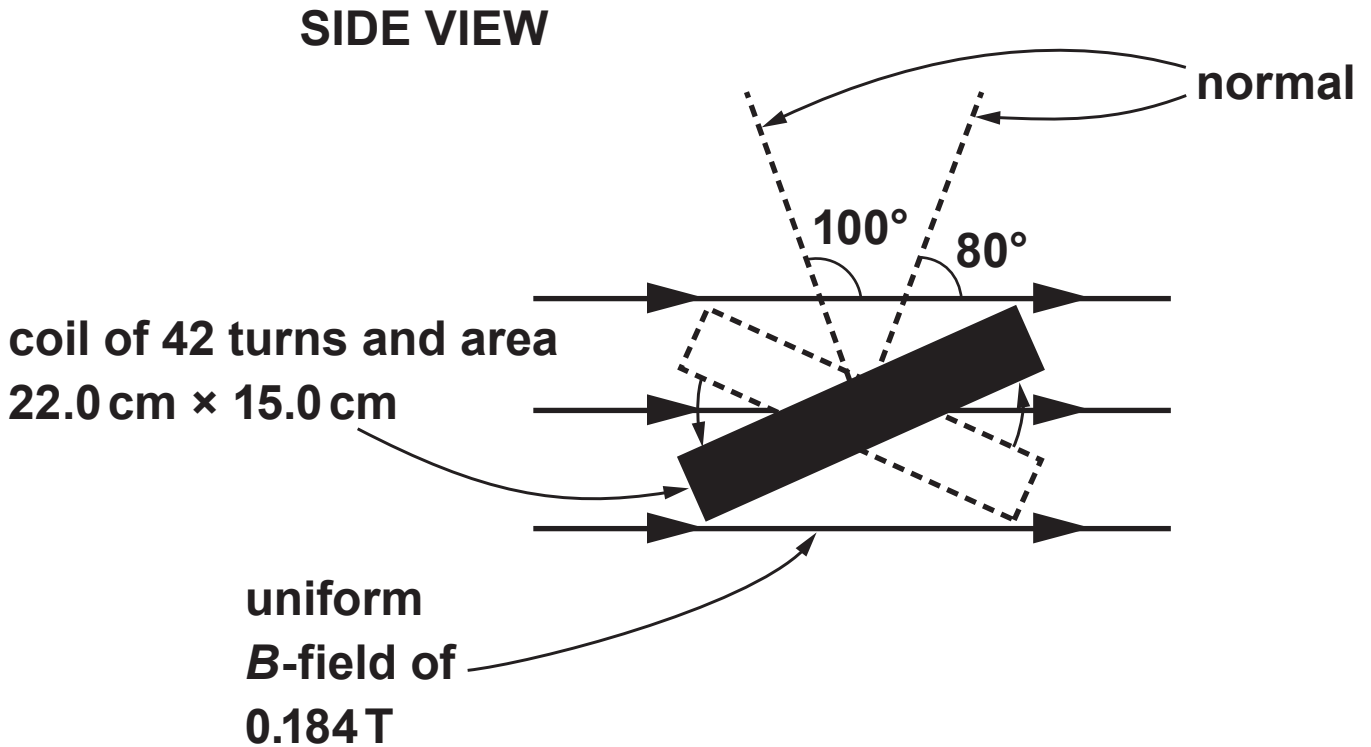

6(c) An oscilloscope is used to display the sinusoidal emf in a different coil rotating at a frequency of 12.5 Hz and producing an RMS pd of 12.0 V. The oscilloscope settings are 5 V per division (vertically) and 20 ms per division (horizontally). Sketch (opposite) a trace that might be seen on the oscilloscope. (Space is provided for your workings.) [3]

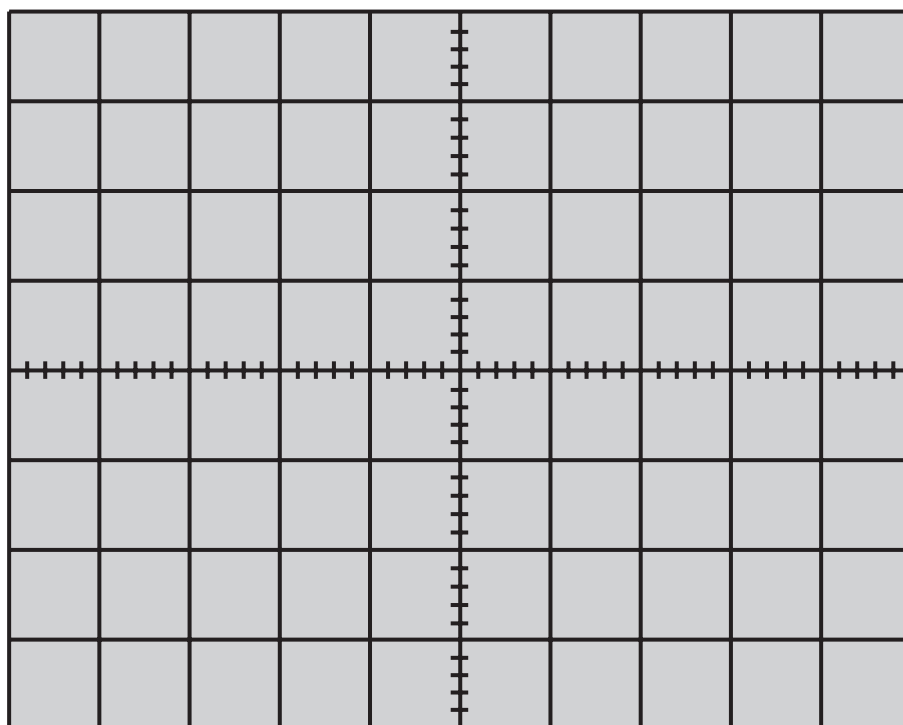

7(b) The parallax angle for a certain star is measured as 0.25 arcseconds. Calculate the distance of the star in light years. (See paragraph 4.) [2]

7(d) What percentage of the Universe is not hydrogen or helium? (See paragraph 10.) [1]

(e) In your own words, explain why absorption corresponding to the Paschen series does not occur in relatively cold stars. (See paragraphs 11 and 12.) [3]

- 7(g) (i) Show that the equation $(M + m)T^2 = a^3$ is valid for the orbit of the Earth around the Sun. (See paragraph 16.) [1]

- (ii) A small planet orbits a star that has a mass $0.32 M_{\text{Sun}}$ and its period of orbit is found to be 0.46 year. Estimate the planet's distance from its star stating any approximation that you make. [2]

SECTION C: OPTIONAL TOPICS

**Option A: Further Electromagnetism
and Alternating Currents**

**Option B: Revolutions in Physics –
Electromagnetism and
Space–Time**

Option C: Materials

**Option D: Biological Measurement and
Medical Imaging**

Option E: Energy Matters

Answer the question on ONE TOPIC ONLY.

**Place a tick (✓) in one of the boxes above, to show
which topic you are answering.**

**You are advised to spend about 20 minutes
on this section.**

Option A: Further Electromagnetism and Alternating Currents

8(a) A sinusoidal pd of 6 V (rms) and frequency 0.9 Hz is supplied to the primary solenoid.

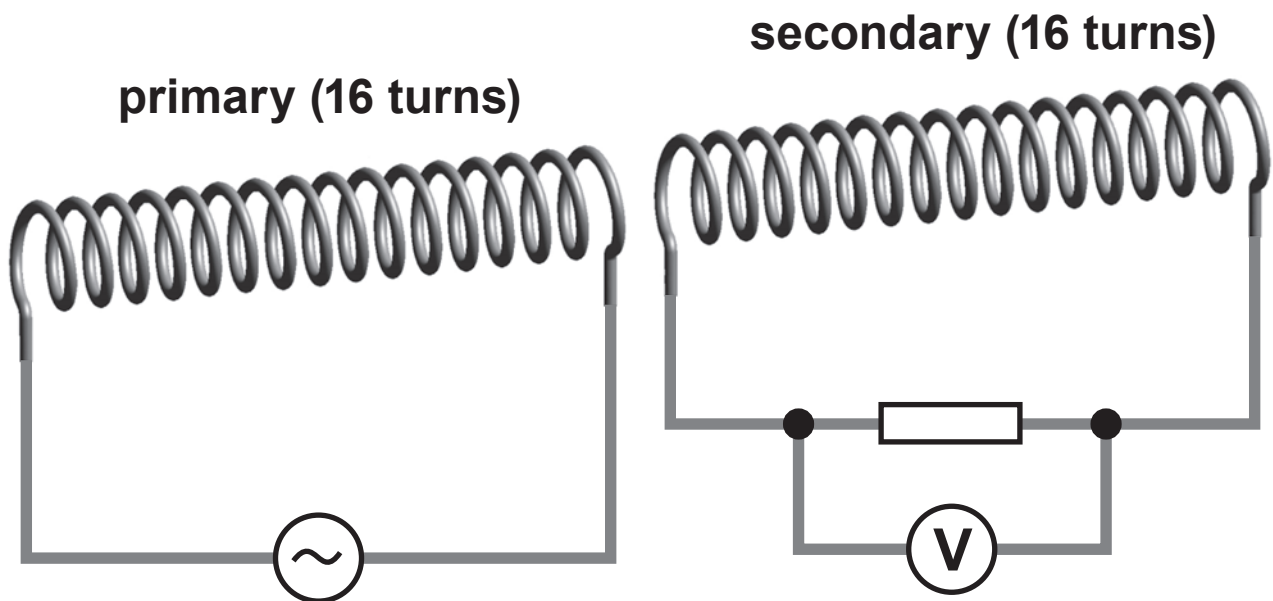

- (i) State how the reading on the voltmeter varies and explain what causes the voltmeter reading to vary. [4]

8(a) (ii) Give a reason why the rms pd measured by the voltmeter will be much lower than 6 V.

[1]

8(b) For the following circuit:

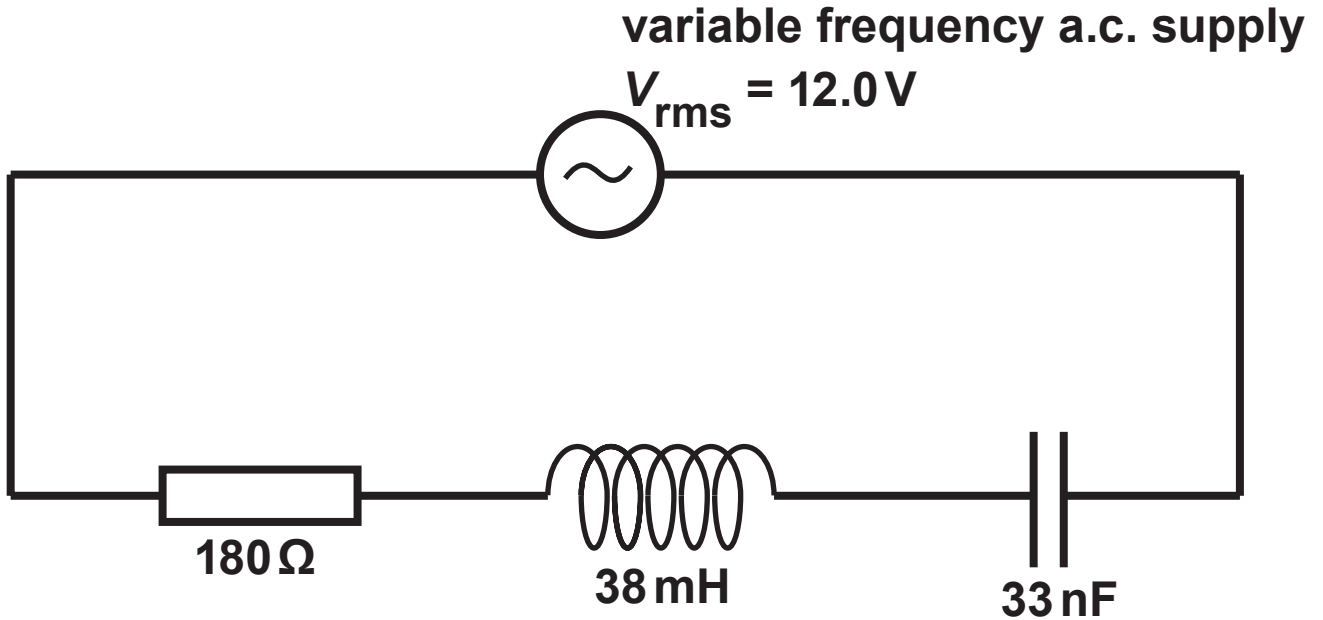

(i) calculate the resonance frequency; [2]

- 8(d) In the high pass filter shown the rms output pd is $\frac{3}{4}$ of the rms pd across the capacitor.

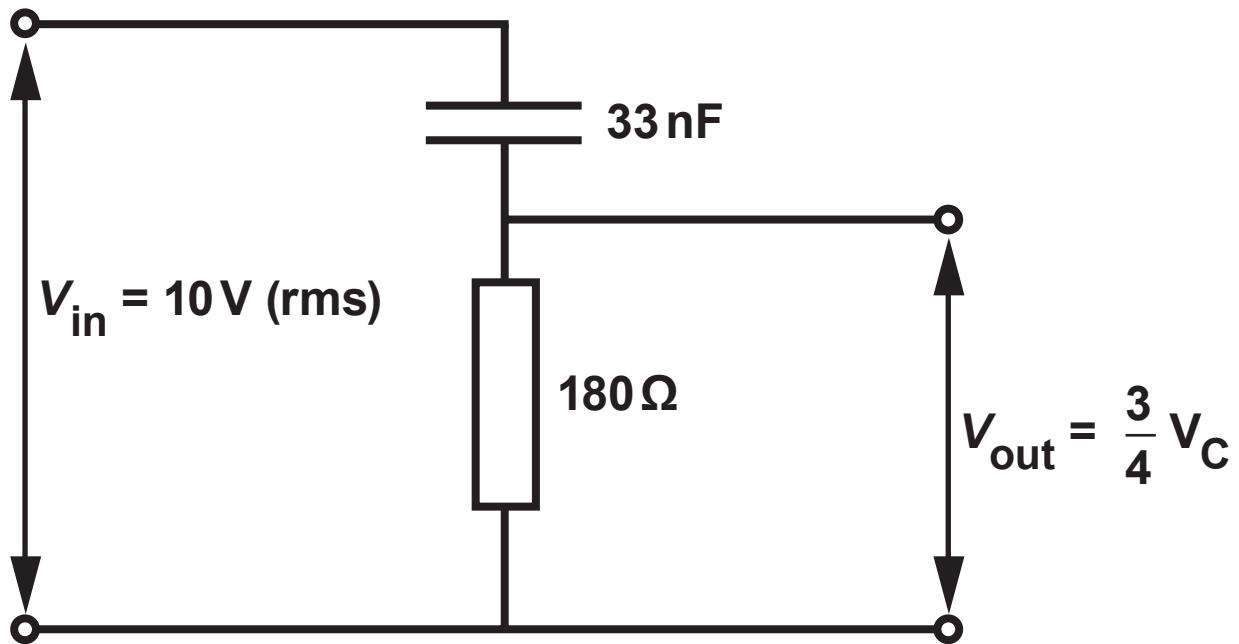

Calculate the frequency of the input pd. [3]

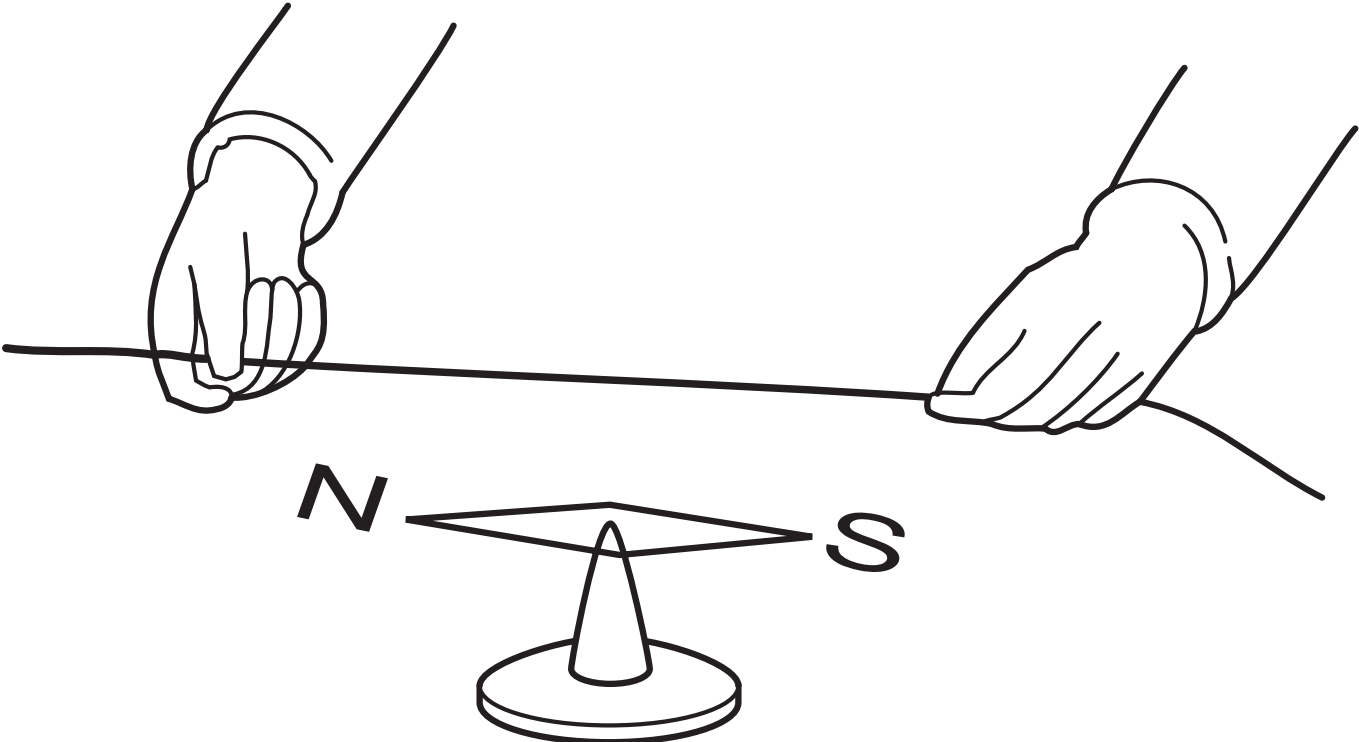

Option B: Revolutions in Physics – Electromagnetism and Space – Time

9. A sketch opposite is given of the apparatus used in a famous experiment of 1820, showing the magnetic effects of an electric current.

(a) (i) Who performed the experiment? [1]

(ii) Part of the apparatus (not shown) was a voltaic pile. What is the modern name for a voltaic pile? [1]

9(a) (iv) The experiment and its results inspired Faraday to start a search which led to his discovery of electromagnetic induction. What was Faraday searching for? [1]

(b) (i) Explain how a magnetic field is represented in Maxwell's vortex ether. Include a labelled diagram of a region containing four vortices. [3]

9(b) (ii) Maxwell wrote about his vortex ether:

“The conception of a particle having its motion connected with that of a vortex by perfect rolling contact may appear somewhat awkward. I do not bring it forward as a mode of connexion existing in nature, or even as that which I would willingly assent to as an electrical hypothesis. It is, however, a mode of connexion which is mechanically conceivable, and easily investigated, and it serves to bring out the actual mechanical connexions between the known electro-magnetic phenomena [...].”

Discuss briefly whether or not the vortex ether served its purpose, even though few physicists – if any – would argue for its existence. [2]

9(c) Describe briefly how Hertz:

- (i) produced electromagnetic waves and how he detected them; [2]**

9(c) (ii) confirmed the transverse nature of the waves; [1]

(iii) measured the wavelength. [2]

- 9(d) (i) State what is meant by a **PROPER TIME INTERVAL** between two events. [1]

- (ii) A spacecraft travels between two space stations, A and B, at a speed of $0.140c$ (that is $4.20 \times 10^7 \text{ m s}^{-1}$). A clock on board the spacecraft records the journey time from A to B as 50.0 s .

Synchronised clocks in the space stations A and B record the spacecraft passing them at times t_A and t_B . Calculate the time interval $(t_B - t_A)$. [Assume A and B to be in fixed positions in an inertial frame.] [3]

Stress



Strain



OPTION C: MATERIALS

10(a) Sketch on the page opposite a typical stress-strain graph for the stretching to breaking point of a ductile metal such as copper. Label on your graph:

- (i) the elastic limit;**
- (ii) the yield point;**
- (iii) the region of plastic deformation;**
- (iv) the breaking point. [6]**

10(b) The diagram shows the arrangement of atoms in a metal crystal in the region of a dislocation.

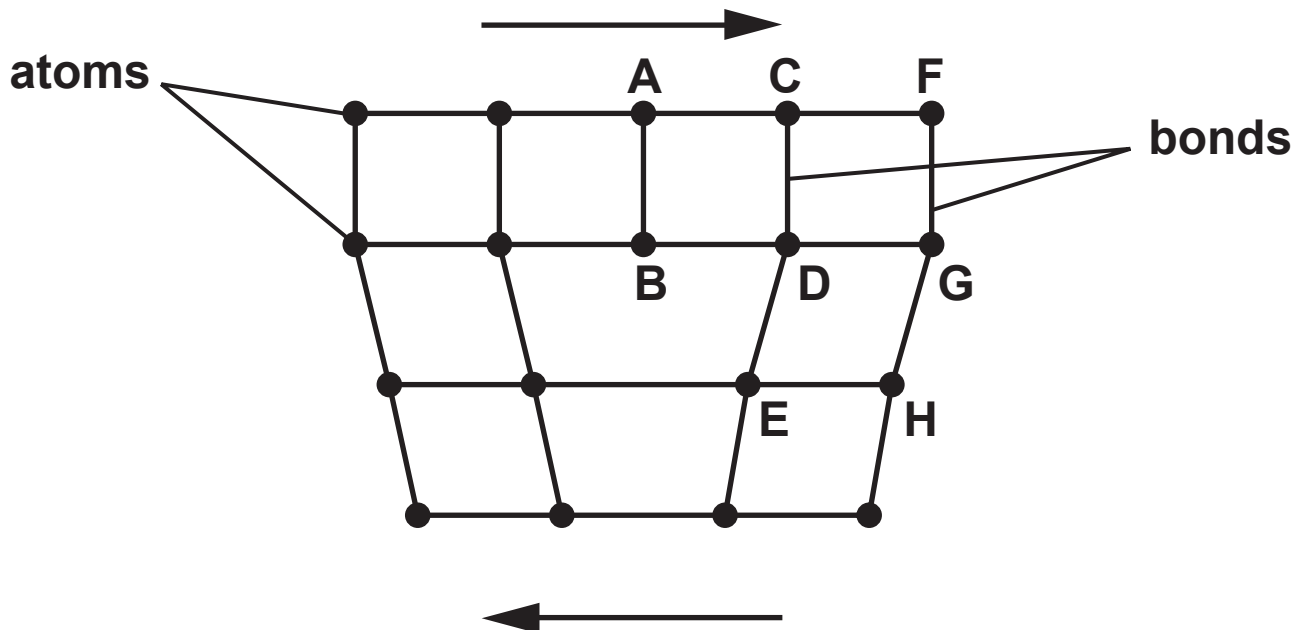

- (i) Using the letters in the diagram, explain how plastic deformation takes place in ductile metals when forces are applied as shown by the arrows. Space is provided on the page opposite so that you can illustrate your answer if you wish to do so (or you may add to the existing diagram). [3]

10(b) (ii) 'Superalloys' in the form of single crystals have recently been developed to withstand extreme conditions of temperature and pressure. IN TERMS OF ATOMIC STRUCTURE, give one reason why superalloys can withstand higher temperatures and pressures than conventional multi-crystal alloys. [1]

(iii) State one application of 'superalloys'. [1]

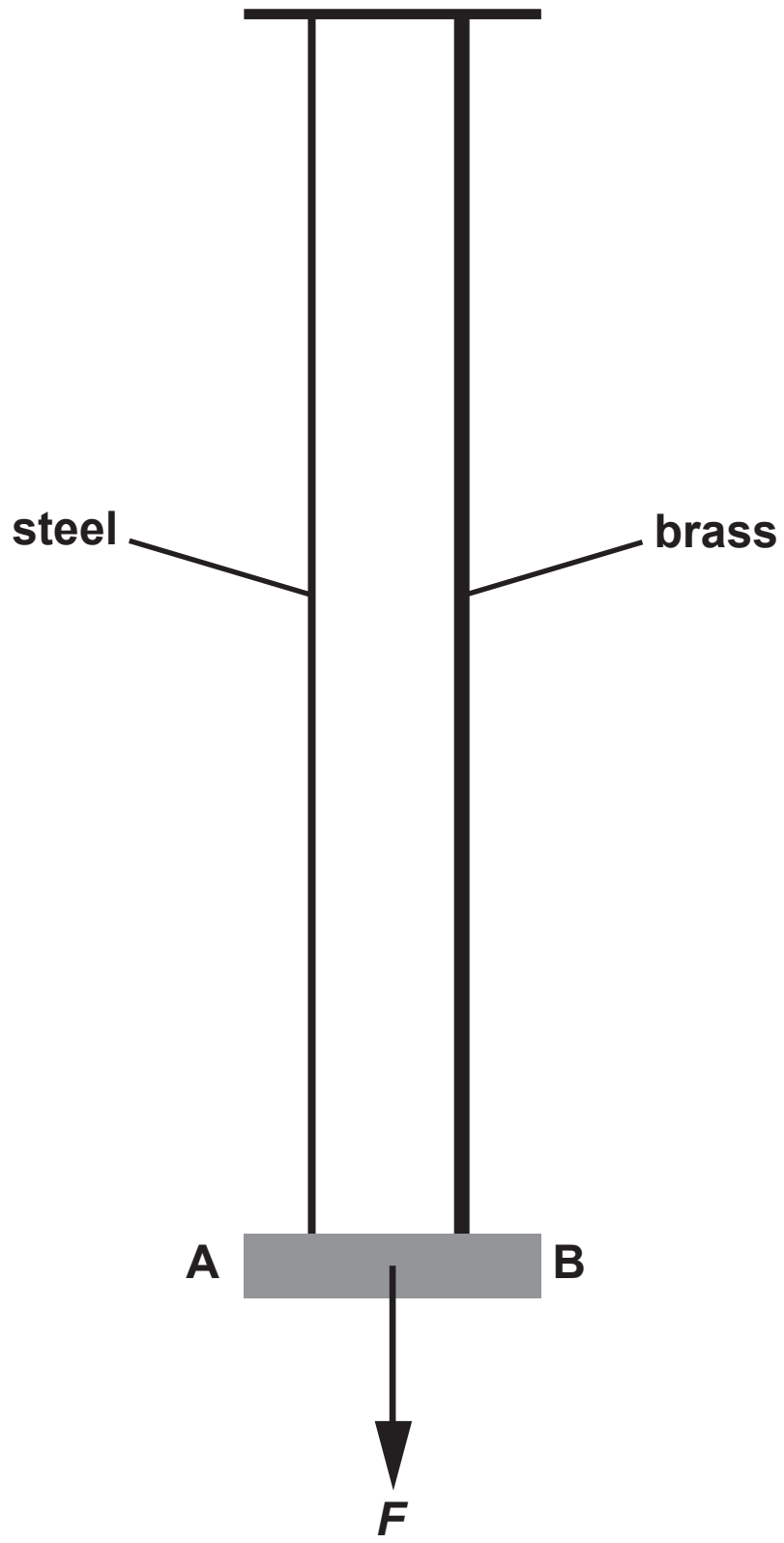

10(c) A light bar (AB) is suspended horizontally from two vertical wires, one of steel and one of brass as shown in the diagram opposite. Each wire is of the same length, though their cross-sectional areas (A_{brass} and A_{steel}) are different. When a force F is applied to the CENTRE of AB the wires EXTEND BY AN EQUAL AMOUNT and the bar remains horizontal.

- (i) Given that the Young modulus of steel is $2.0 \times 10^{11} \text{ N m}^{-2}$, and that of brass is $1.0 \times 10^{11} \text{ N m}^{-2}$, show clearly that $A_{\text{brass}} = 2A_{\text{steel}}$. [2]

10(c) (ii) Determine the tension in each wire when $F = 100 \text{ N}$. [1]

(iii) Hence calculate the extension in the steel wire when $F = 100 \text{ N}$. The initial length of wire is 2.0 m and its cross-sectional area is $2.8 \times 10^{-7} \text{ m}^2$. [2]

(iv) Calculate the energy stored in the steel wire when $F = 100 \text{ N}$. [2]

10(c) (v) Without further calculation, comment on the energy stored in the brass wire when $F = 100\text{ N}$ and justify your answer. [2]

Intensity



λ_{min}

Wavelength

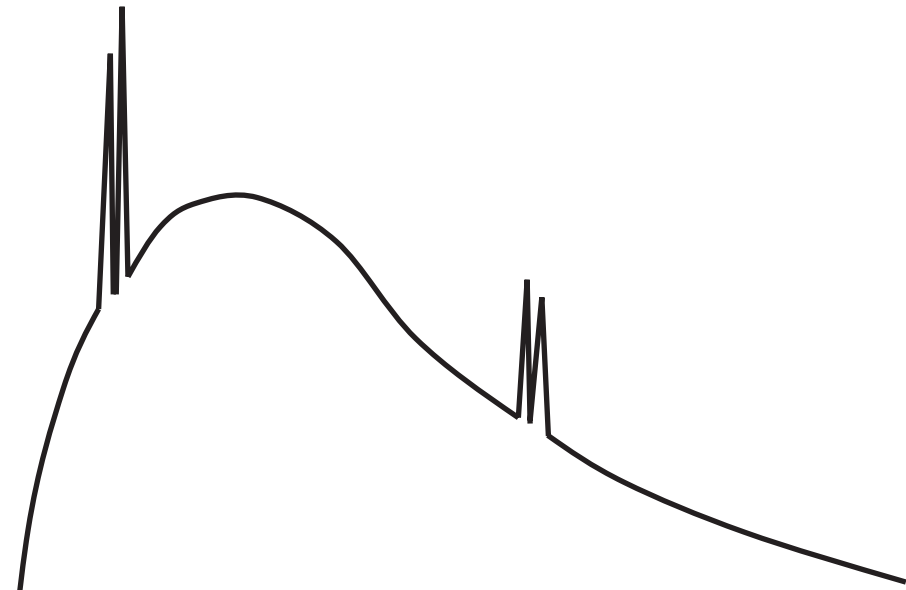

Option D: Biological Measurement and Medical Imaging

11. The diagram opposite shows a typical intensity spectrum for the output of an X-ray tube using a tungsten target.

(a) (i) Label the **BACKGROUND SPECTRUM** and the **LINE SPECTRUM**. [1]

(ii) Explain clearly how each of the two spectra is produced; [4]

(i) line spectrum;

11(a) (ii) (II) background spectrum.

11(b) You have the choice of the following forms of medical imaging:

X-ray ultrasound A-scan

ultrasound B-scan MRI scan CT scan

Which of the above would be the most suitable to image the following? Give a reason for each answer. [6]

(i) The development of an unborn baby.

11(b) (ii) A lung tumour in a patient who wears a pacemaker (metal container).

(iii) A brain tumour in an adult patient.

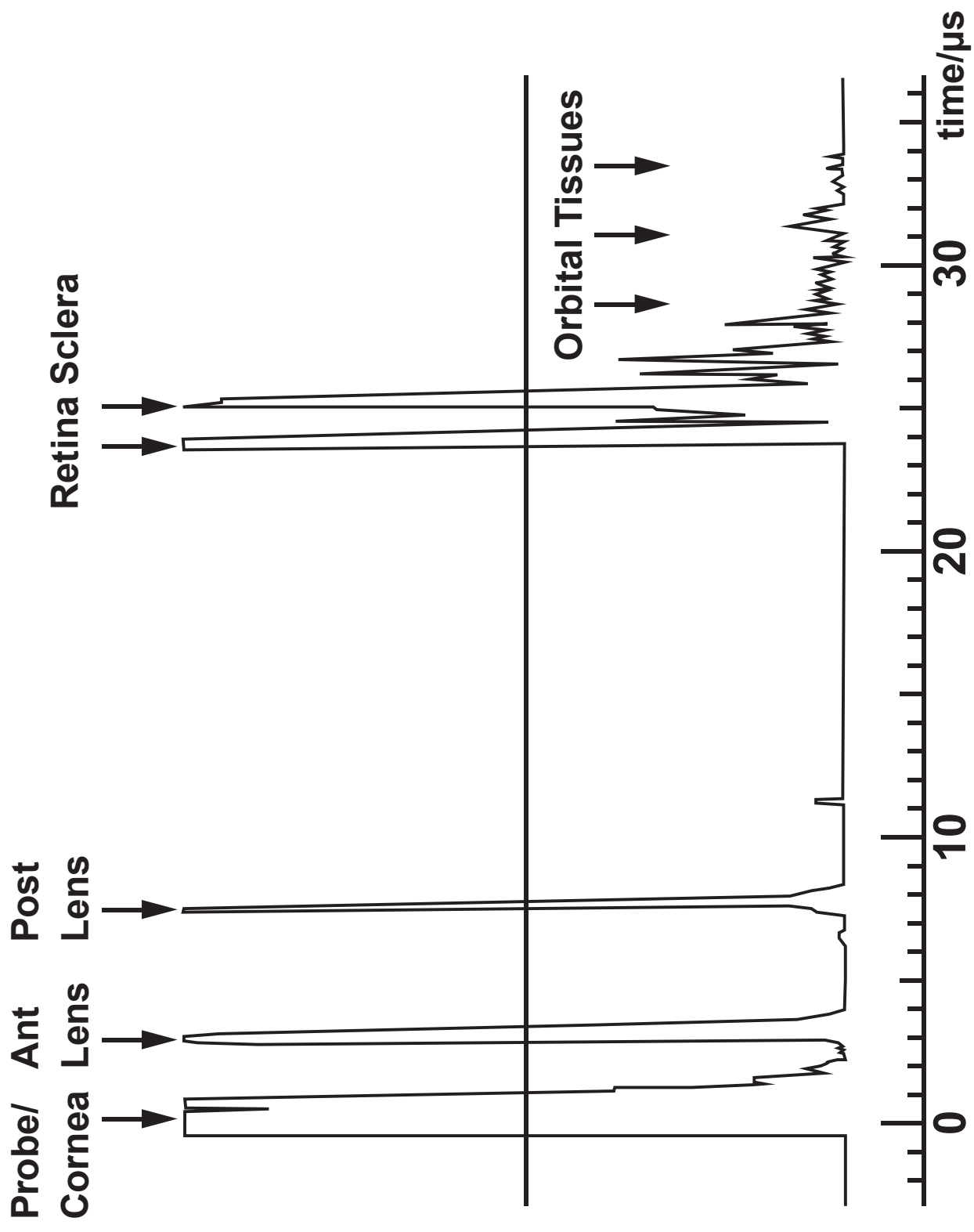

11(c) **Ultrasound A-scans can be used on the human eye in order to obtain accurate measurements of the thickness of the lens. Opposite is a copy of such a scan.**

Use the information in the diagram to calculate the lens thickness. The spike labelled 'Ant Lens' corresponds to the front of the lens and the spike labelled 'Post Lens' corresponds to the back of the lens. The velocity of ultrasound in the lens is 1640 m s^{-1} . [3]

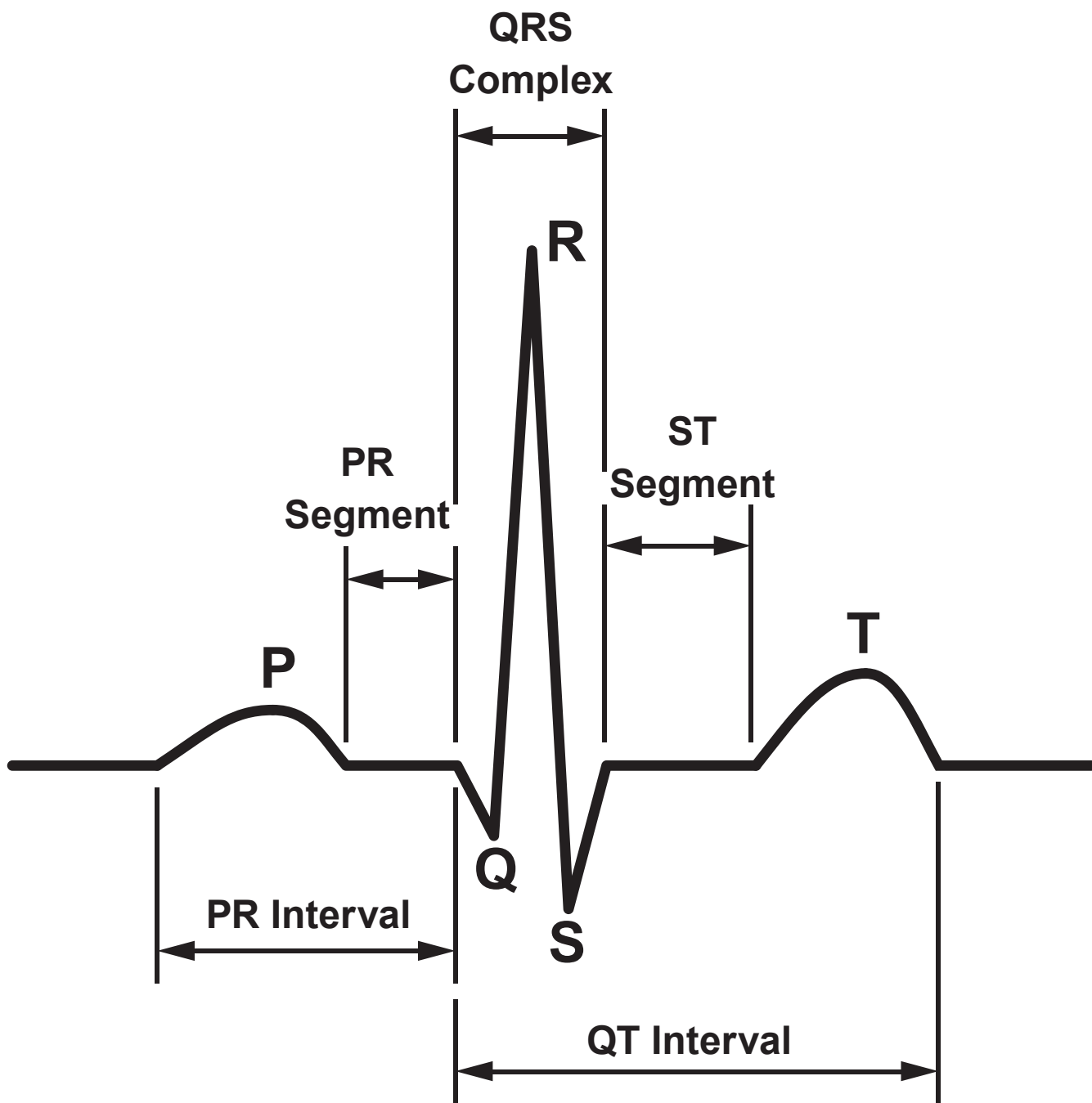

11(d) The diagram opposite shows an ECG trace for a healthy person.

What changes would you expect to the pattern if:

- (i) a person had high blood pressure due to the ventricles working too hard; [2]

- (ii) the atrium was not contracting properly; [1]

**11(d) (iii) the ECG trace was taken for a person
who had recently had a mild heart attack
(myocardial infarction MI)? [1]**

Option E: Energy matters

12. One possible scheme to decrease CO₂ emissions for the UK is to build a Severn barrage and to use the twice daily motion of tidal water in the Bristol channel for electricity production.



- (a) Discuss briefly two points:
- (i) in favour of this scheme (note that merely stating: 'to decrease CO₂ emissions' will not be enough for a mark); [2]

12(b) Write down the two energy CONVERSIONS associated with this scheme. [2]

- 12(c) A column of liquid of density, ρ , has an area, A . The column is increased in height by a distance, h (see diagram). Show that the increased potential energy is given by:

$$PE = \frac{1}{2} A\rho gh^2$$

where g is the acceleration due to gravity. [3]

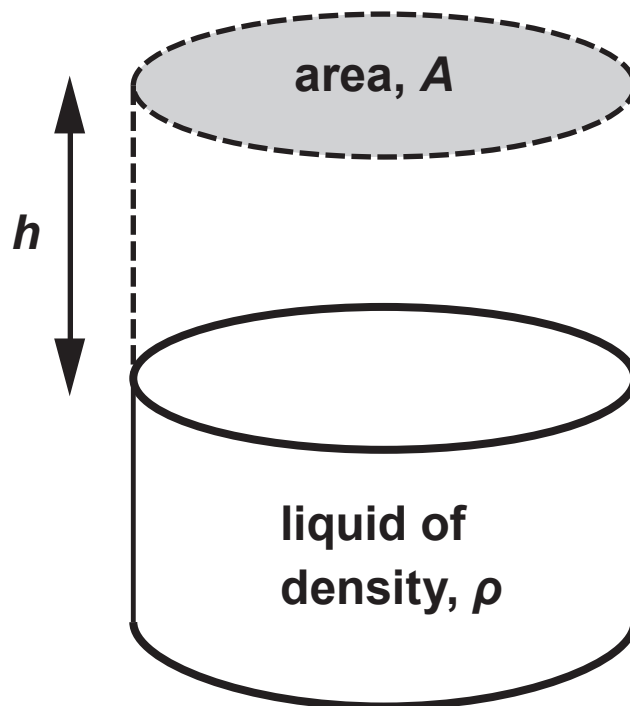

12(e) (i) Another scheme has been proposed without the need to trap the water at high tide. This would employ turbines rotating almost continually as the tide flows in both directions. State the TWO main advantages of this type of scheme. [2]

- 12(e) (ii) The mean cross-sectional area of the Severn estuary is approximately $3 \times 10^5 \text{ m}^2$ and its mean tidal speed is approximately 3 m s^{-1} . By considering the mass and energy of the water passing this cross-section per second, estimate the mean power obtainable by this alternative method (density = 1025 kg m^{-3} and efficiency = 75%). [4]

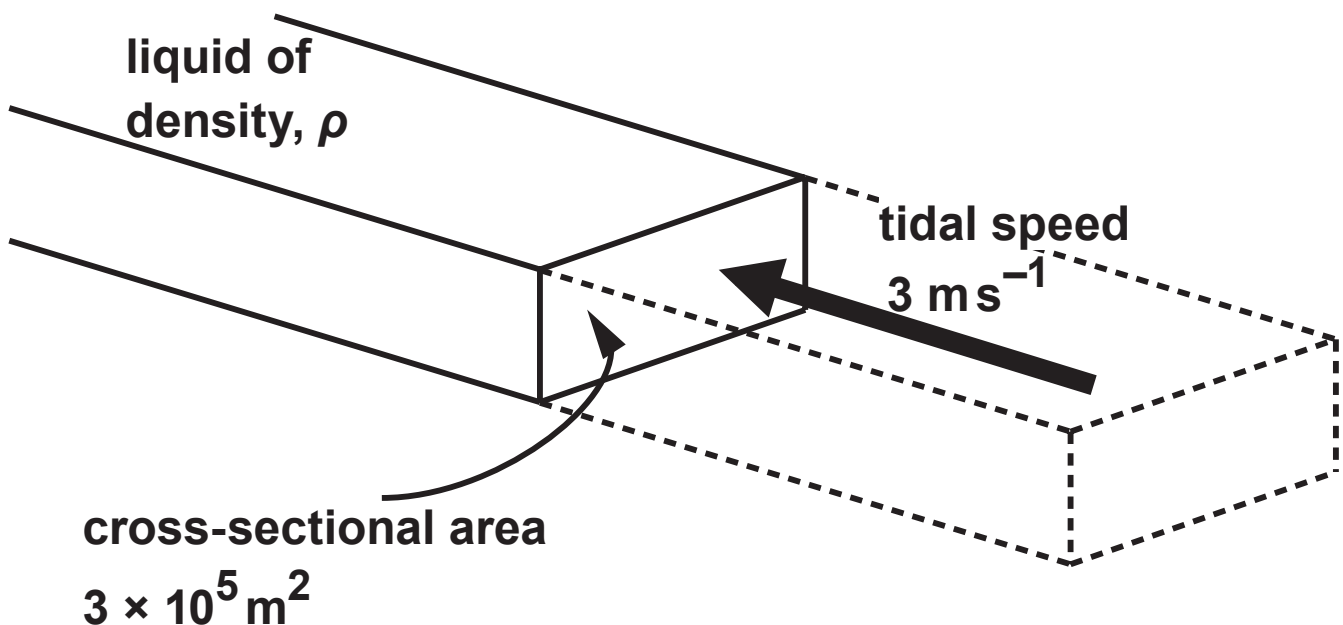

12(e) (iii) Explain briefly why the MEAN tidal speed included in the calculation above is an underestimate of the value that should actually be used. [1]

END OF PAPER

