

Surname	Centre Number	Candidate Number
Other Names		2



GCE A level

1325/01

PHYSICS

ASSESSMENT UNIT PH5:

ELECTROMAGNETISM, NUCLEI & OPTIONS

A.M. MONDAY, 18 June 2012

1³/₄ hours

ADDITIONAL MATERIALS

In addition to this paper, you will require a calculator, a **Case Study Booklet** and a **Data Booklet**.

INSTRUCTIONS TO CANDIDATES

Use black ink or black ball-point pen. Do not use gel pen or correction fluid.

Write your name, centre number and candidate number in the spaces at the top of this page.

Write your answers in the spaces provided in this booklet.

INFORMATION FOR CANDIDATES

This paper is in 3 sections, **A**, **B**, and **C**.

Section A: 60 marks. Answer **all** questions. You are advised to spend about 1 hour on this section.

Section B: 20 marks. The Case Study. Answer **all** questions. You are advised to spend about 20 minutes on this section.

Section C: Options; 20 marks. Answer **one option only**. You are advised to spend about 20 minutes on this section.



SECTION A

1. The thickness of paper is measured using a beta radiation source and detector (see below).

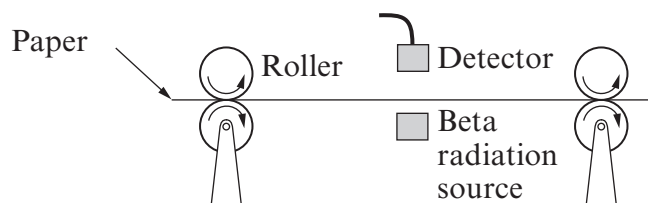

- (a) Explain why it would be inappropriate to use either alpha radiation or gamma radiation for this task. [2]

.....

.....

.....

.....

.....

- (b) The beta radiation source most commonly used is strontium-90 which decays as shown. Place the correct numbers on the dotted lines. [2]



- (c) The half life of strontium-90 is 28.8 years. Show that its decay constant is $7.6 \times 10^{-10} \text{ s}^{-1}$. [2]

.....

.....

.....

.....

.....



(d) If the initial activity of the strontium-90 source is 140 GBq, calculate its activity after 10 years. [2]

.....

.....

.....

.....

.....

(e) Calculate the mass of strontium-90 required to produce an activity of 140 GBq. [3]

.....

.....

.....

.....

.....

.....

.....

.....

1325
010003



2. One of the nuclear reactions that occurs inside a nuclear power station is:

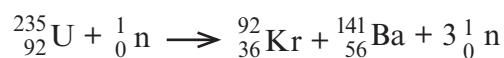

The masses of the relevant nuclei are as follows:

$$\text{Mass of } {}_{92}^{235}\text{U} = 234.9933 \text{ u} \quad \text{Mass of } {}_{36}^{92}\text{Kr} = 91.9064 \text{ u}$$

$$\text{Mass of } {}_{56}^{141}\text{Ba} = 140.8836 \text{ u} \quad \text{Mass of } {}_0^1\text{n} = 1.0087 \text{ u}$$

- (a) Calculate the energy released in this nuclear reaction (1 u = 931 MeV). [3]

.....

.....

.....

.....

.....

.....

.....

.....

.....

.....

- (b) Explain briefly how this reaction can lead to a chain reaction. [2]

.....

.....

.....

.....

.....

.....

.....

.....

.....

.....



(c) Explain briefly the different purposes of the moderator and control rods in a nuclear reactor. [3]

.....

.....

.....

.....

.....

.....

.....

.....

.....

.....

(d) Discuss briefly the problems associated with disposing of waste products from a nuclear power station. [2]

.....

.....

.....

.....

.....

.....

1325
010005



3. (a) (i) A capacitor has plates of area $8.2 \times 10^{-4} \text{ m}^2$ and a separation of 0.77 mm. Calculate the capacitance of the capacitor assuming that there is air (or a vacuum) between the plates. [2]

.....

.....

.....

.....

- (ii) Keeping the dimensions of the capacitor the same, how could you increase its capacitance? [1]

.....

- (b) Another capacitor is charged and discharged using the following circuit.

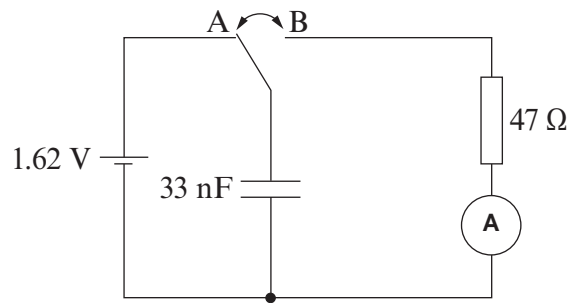

- (i) Calculate the charge stored by the capacitor when fully charged. [2]

.....

.....

.....

.....



- (ii) The fully charged capacitor is now discharged through the 47Ω resistor by moving the switch to B. Calculate the charge still remaining on the capacitor after it has been discharging for $50.0 \mu\text{s}$ and comment on the magnitude of your answer. [3]

.....

.....

.....

.....

.....

.....

.....

.....

.....

- (iii) The capacitor is charged and discharged a total of 20 000 times per second. Calculate the average current through the ammeter. [2]

.....

.....

.....

.....

.....

1325
010007



4. (a) Sketch the magnetic field due to the current-carrying wire shown.

[2]

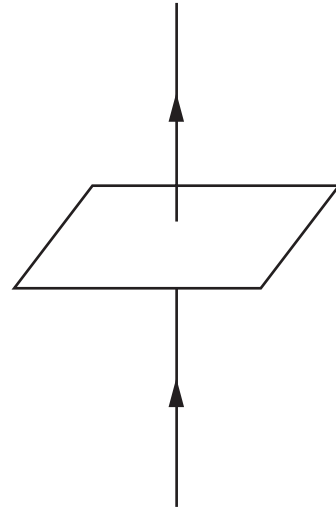

- (b) Two long, straight wires carry currents as shown.

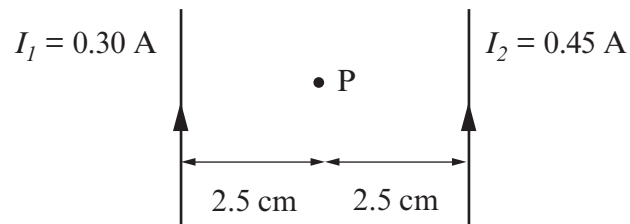

- (i) Calculate the resultant magnetic field strength at point P in the above diagram and **state its direction**. [4]

.....

.....

.....

.....

.....

.....

.....

.....

.....

.....



(ii) Explain why there is an attractive force between the two long wires in the diagram on the opposite page. [3]

.....

.....

.....

.....

.....

.....

1325
010009



5. Electrons flow through a gold wafer which is used as a Hall probe.

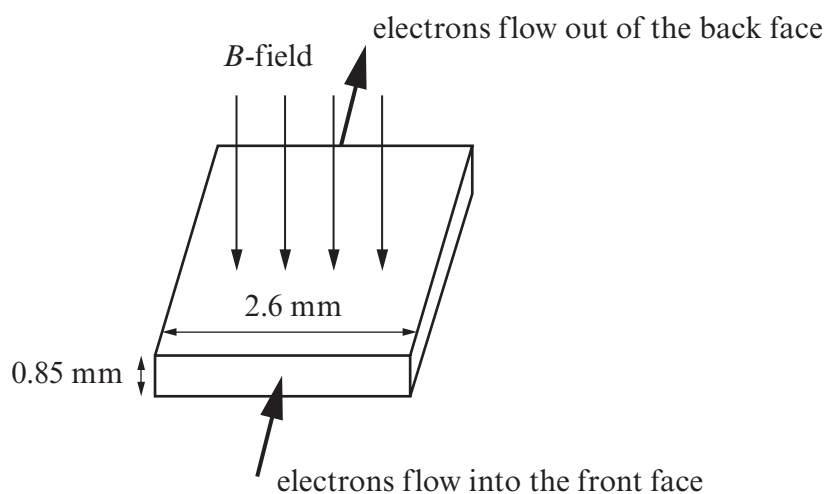

- (a) Explain which face of the wafer becomes negatively charged due to the Hall effect. [3]

.....

.....

.....

.....

.....

.....

.....

- (b) The electric field due to the Hall voltage is $3.2 \times 10^{-6} \text{ V m}^{-1}$. Calculate the Hall voltage. [2]

.....

.....

.....

.....

.....

.....

.....



(c) The following equation is used in conjunction with the Hall effect: $eE = Bev$. State what the forces eE and Bev are and explain why they are equal. [2]

.....

.....

.....

.....

.....

.....

(d) The current flowing in the wafer is 0.82 A and the concentration of free electrons in gold is $5.9 \times 10^{28} \text{ m}^{-3}$. Calculate the magnetic field strength, B . [Hint: Use $I = nAve$] [3]

.....

.....

.....

.....

.....

.....

.....

.....

.....

1325
0100 11



6. (a) State Faraday's law of electromagnetic induction. [2]

.....

.....

.....

- (b) A circular copper heating ring works by being placed in a sinusoidally varying magnetic field. A large sinusoidal current is then induced in the ring and the ring becomes hot (see below).

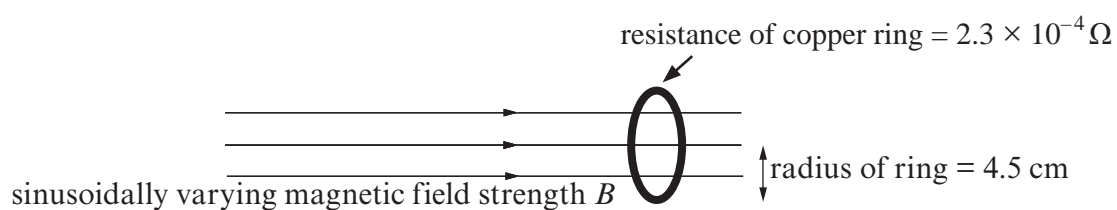

- (i) The maximum rate at which the magnetic field strength changes is 72 T s^{-1} . Show that the maximum current flowing in the ring is approximately 2000 A. [4]

.....

.....

.....

.....

.....

.....

.....

.....

.....

.....



(ii) Calculate the rms value of the induced current. [2]

.....

.....

.....

.....

(iii) Calculate the mean power dissipated in the heating ring. [2]

.....

.....

.....

.....

1325
010013



SECTION B

The questions refer to the Case Study.
Direct quotes from the original passage will not be awarded marks.

7. (a) Explain briefly why all the Solar System planets appear on the same horizontal line on the graph below. [1]

.....

.....

.....

.....

Graph of Star Mass (relative to our Sun) v Planet Distance from the Star

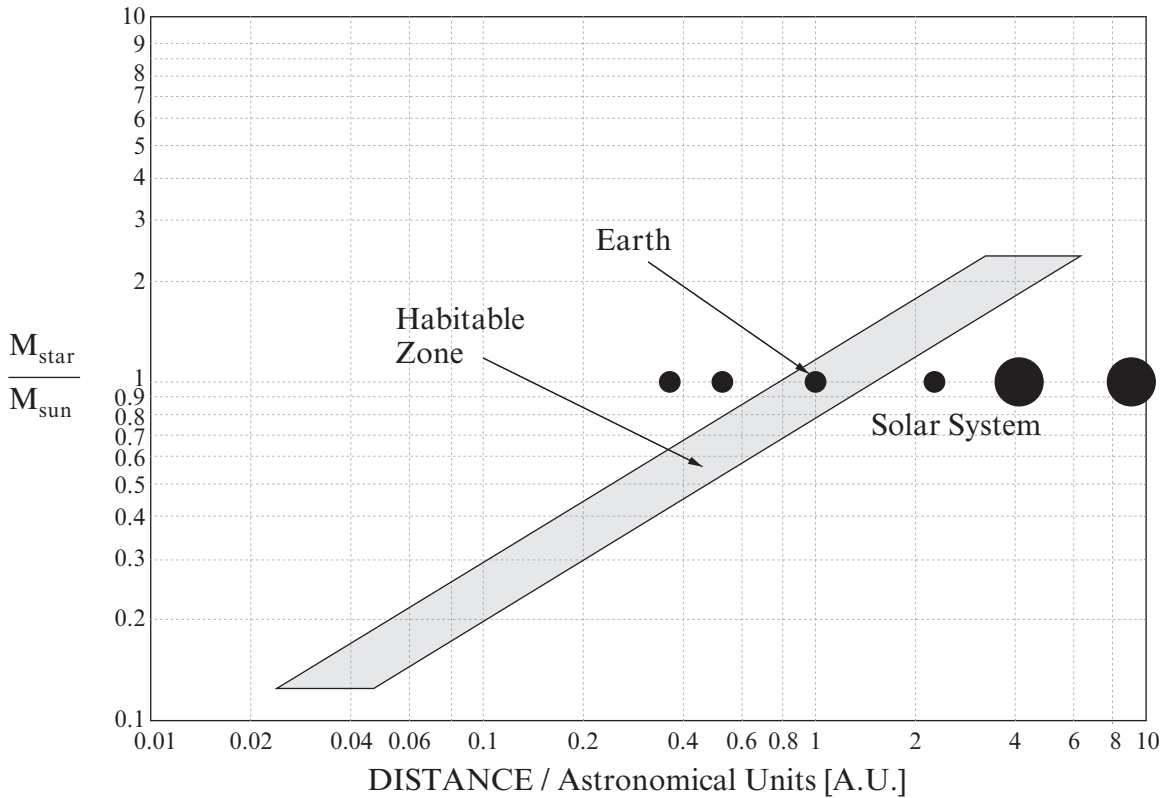

- (b) Place crosses on the graph to represent:
- (i) an exoplanet orbiting a star twice the mass of the Sun and at a distance four times the Sun-Earth separation; [1]
 - (ii) an exoplanet orbiting a star 0.25 times the mass of the Sun and at a distance of 0.04 times the Sun-Earth separation. [1]



(c) Explain whether or not abundant liquid water could be found on **each** of the planets in part (b). [See also Paragraph 2.] [2]

.....

.....

.....

.....

(d) Derive the equation $v_s = M_p \sqrt{\frac{G}{M_s d}}$ from the equations in the box in Paragraph 8. [2]

.....

.....

.....

.....

.....

.....

.....

.....

.....

.....

(e) Explain how the equation $v_s = M_p \sqrt{\frac{G}{M_s d}}$ agrees with the statement “the Doppler method is most sensitive to large planets which are close to small stars”. [Paragraph 8.] [4]

.....

.....

.....

.....

.....

.....

.....

.....

.....

.....

1325
010015



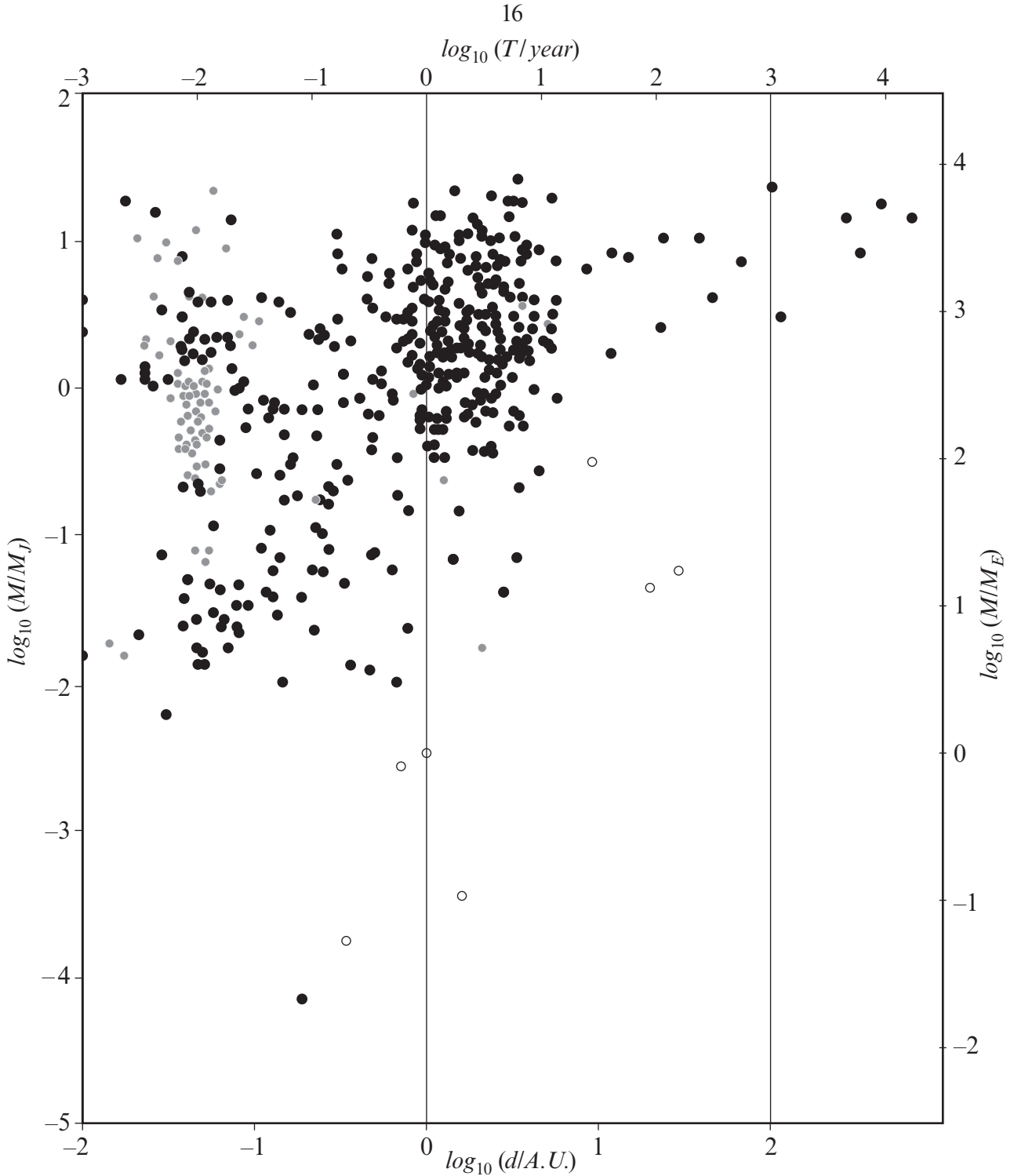

(f) Explain whether or not the orbital parameters scatter plot (above) confirms the statement “the Doppler method is most sensitive to large planets which are close to small stars.” [2]

.....

.....

.....

.....



(g) **Place a cross** to show the position of the planet Earth on the orbital parameters scatter plot. [2]

(h) Jupiter’s radius is $\frac{1}{20}$ that of the Sun. Calculate the fractional (or percentage) change in the Sun’s apparent intensity as Jupiter transits in front of the Sun (as measured by a very distant observer). [Paragraph 9.] [2]

.....
.....
.....
.....
.....
.....

(i) Explain briefly how radial velocity measurements combined with transit measurements lead to the mean density of an exoplanet. [Paragraph 21.] [3]

.....
.....
.....
.....
.....
.....
.....
.....
.....

Source

page 16 – http://en.wikipedia.org/wiki/File:Exoplanet_Period–Mass_Scatter.png



SECTION C: OPTIONAL TOPICSOption A: **Further Electromagnetism and Alternating Currents**Option B: **Revolutions in Physics - Electromagnetism and Space-Time**Option C: **Materials**Option D: **Biological Measurement and Medical Imaging**Option E: **Energy Matters**

Answer the question on **one topic only**.

Place a tick (✓) in one of the boxes above, to show which topic you are answering.

You are advised to spend about 20 minutes on this section.



Option A: Further Electromagnetism and Alternating Currents

C8. (a) A long solenoid is used in a LCR circuit.

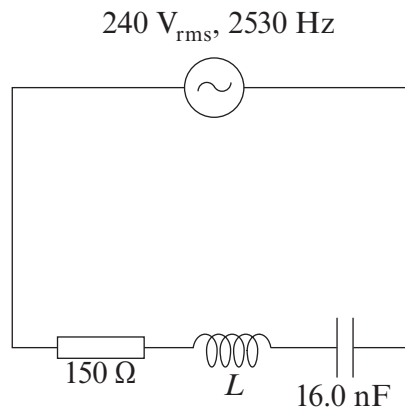

- (i) If the resonance frequency of the circuit is 2530 Hz, calculate L , the inductance of the solenoid. [3]

.....

.....

.....

.....

.....

.....

.....

- (ii) Explain why the rms current at resonance is 1.6 A. [2]

.....

.....

.....

.....

- (iii) Calculate the rms pd across the capacitor at resonance. [3]

.....

.....

.....

.....

.....

.....



(iv) Write down the following values at resonance: [4]

- the rms pd across the inductor;
- the mean power dissipation in the inductor;
- the mean power dissipation in the capacitor;
- the phase angle between the applied voltage and the current.

(b) The self-inductance of a coil is defined by the equation $E = -L \frac{\Delta I}{\Delta t}$.
Give the meanings of: [2]

E

L

$\frac{\Delta I}{\Delta t}$

(c) The magnetic field strength, B , at the centre of a long solenoid is given by the equation $B = \mu_0 n I$.
Use Faraday's law to show that the self inductance of a long solenoid is given by

$$L = \mu_0 n^2 l A$$

where l is the length of the solenoid and A is its cross-sectional area. [4]

.....

.....

.....

.....

.....

.....

.....

.....

.....

.....



- (d) A long solenoid is of length 2.70 m, has 3400 turns per unit length and its turns have a radius of 4.50 cm. Calculate its self-inductance. [2]

.....

.....

.....

.....

.....

.....



Option B: Revolutions in Physics

- C9.** (a) The diagram below was used by Thomas Young in connection with the behaviour of waves.

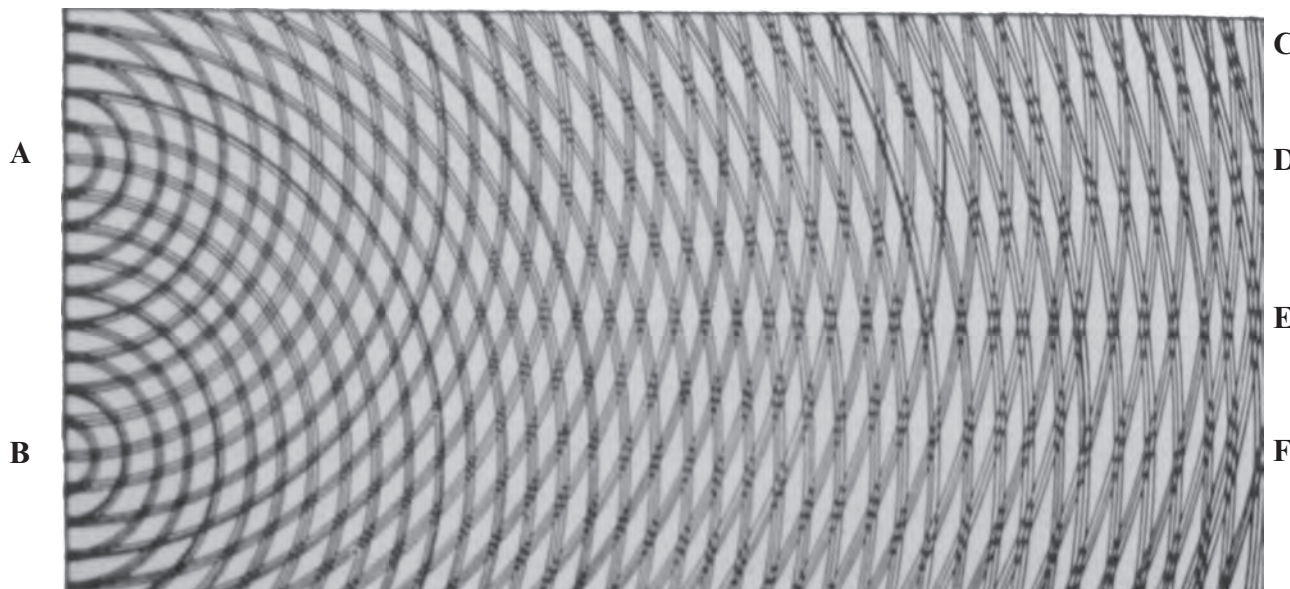

- (i) What does the diagram show?
As part of your answer, you should label significant features. [2]

.....

.....

.....

.....

- (ii) Young's experiments, and his interpretation of them, are now seen as the rebirth of the wave theory of light. How did the theories proposed earlier by Newton and by Huygens differ (if at all) from Young's theory? [3]

.....

.....

.....

.....

.....

.....

.....

.....



- (b) (i) Describe the experiment in which Faraday discovered *electromagnetic induction*. Include a sketched labelled diagram. [4]

.....

.....

.....

.....

.....

.....

.....

.....

.....

.....

.....

.....

.....

.....

.....

- (ii) What did Faraday mean by *magnetic lines of force*, and what use did he make of them in describing and/or explaining electromagnetic phenomena? [2]

.....

.....

.....

.....

- (iii) How did Maxwell represent lines of force in his vortex ether? [2]

.....

.....

.....

.....



(c) (i) State the two postulates on which Einstein's *Special Theory of Relativity* is based. [2]

.....

.....

.....

.....

(ii) A charged pion moving in the x -direction at a speed of $0.60 c$ activates a detector placed at $x = 0$, and decays at $x = 0.36$ m.

(I) Calculate the *proper time* between the events of the pion being detected and the pion decaying. [4]

.....

.....

.....

.....

.....

.....

.....

.....

.....

.....

(II) What does this *proper time* tell us? [1]

.....

.....

.....



Option C: Materials

C10. (a) Materials can be classified as being *crystalline*, *amorphous* or *polymeric*. Choose two of the terms in italics and explain their meaning in terms of their microscopic structure and give one example of each of your chosen materials. [3]

.....

.....

.....

.....

.....

.....

.....

.....

.....

.....



- (b) The bar in the figure below is made from a single piece of material. It consists of two segments of equal length $L_0/2$ and cross-sectional area A and $2A$.
The diagram is not drawn to scale

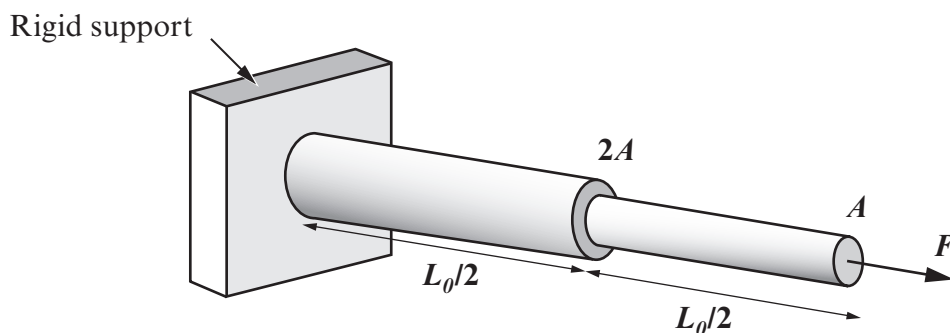

- (i) Show that the **total** extension Δx of the bar under the action of an applied force F , as shown in the diagram, can be given by

$$\Delta x = \frac{3FL_0}{4AY}$$

where Y represents the Young Modulus of the material in the bar.

[3]

.....

.....

.....

.....

.....

.....

.....

.....

.....

.....



- (ii) The graph shows the variation of extension with applied force for the segment of cross-section A .

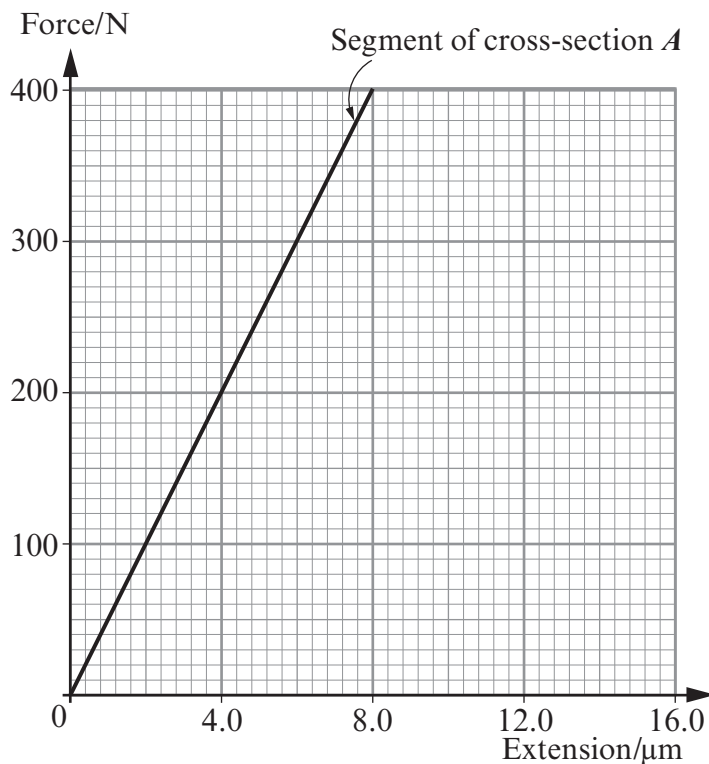

- (I) Draw (on the same grid) the expected force-extension graph for the segment of cross-section $2A$. [1]
- (II) Determine the Young modulus of the metal in the bar given that $L_0 = 4.0$ m and $A = 5 \times 10^{-4} \text{ m}^2$. [3]

.....

.....

.....

.....

.....

.....

.....

.....

- (III) Calculate the elastic potential energy stored in the bar when $F = 200$ N. [3]

.....

.....

.....

.....

.....

.....



- (c) (i) When a specimen of rubber is gradually loaded and then unloaded it may show *elastic hysteresis* and *permanent set*. Explain the meaning of the terms in italics. Illustrate your answer with a sketch of the load-extension graph which would be obtained. [3]

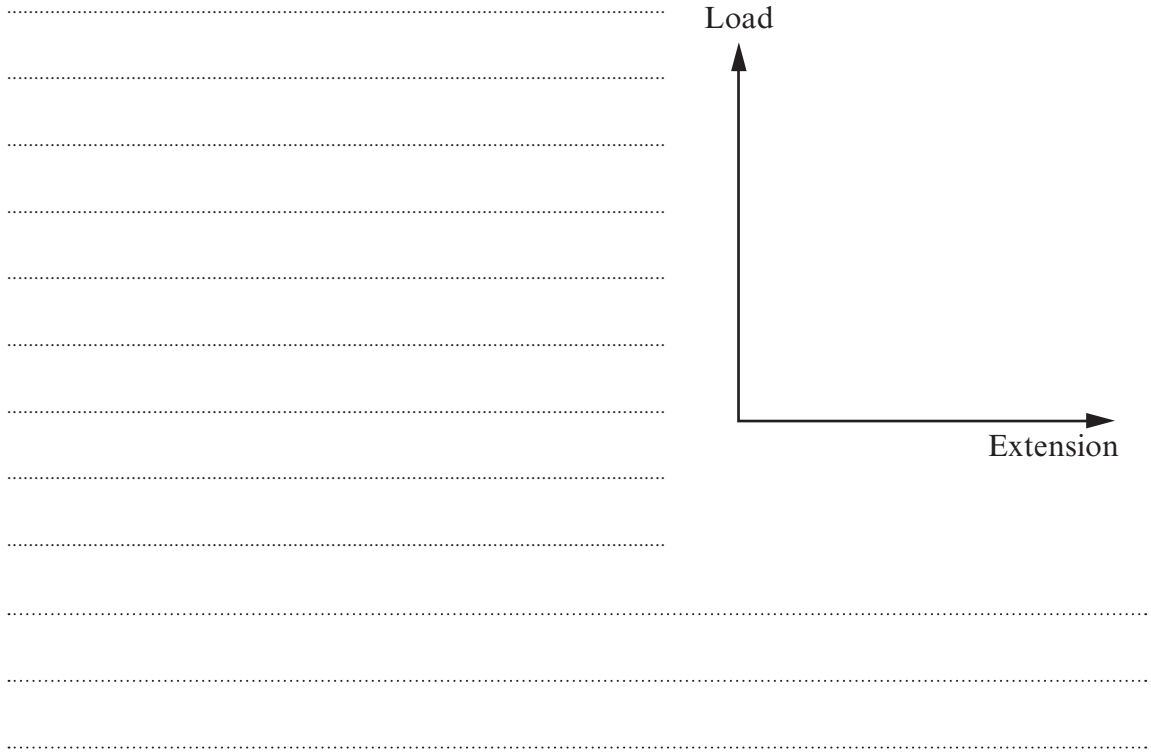

(ii) By referring to the molecular structure of rubber explain why

(I) rubber has a low value of the Young modulus compared with metals. [2]

.....

.....

.....

.....

.....

.....

(II) the value of the Young modulus increases with a rise in temperature. [2]

.....

.....

.....

.....

.....

.....



Option D: Biological Measurement and Medical Imaging

- C11. (a)** (i) Ultrasound can be used to carry out two different types of test, an amplitude scan (A-scan) and a brightness scan (B-scan). State the differences in the type of information obtained from an A-scan and a B-scan. [2]

.....

.....

.....

.....

- (ii) Give an example of when a B-scan would be used in medicine. [1]

.....

.....

- (iii) An A-scan is used to determine the thickness of a layer of skin and fat in a patient's body. The grid below shows the interval between the initial pulse and the reflected pulse on a cathode ray oscilloscope (CRO). The time base is set so that 1 cm represents $2 \mu\text{s}$.

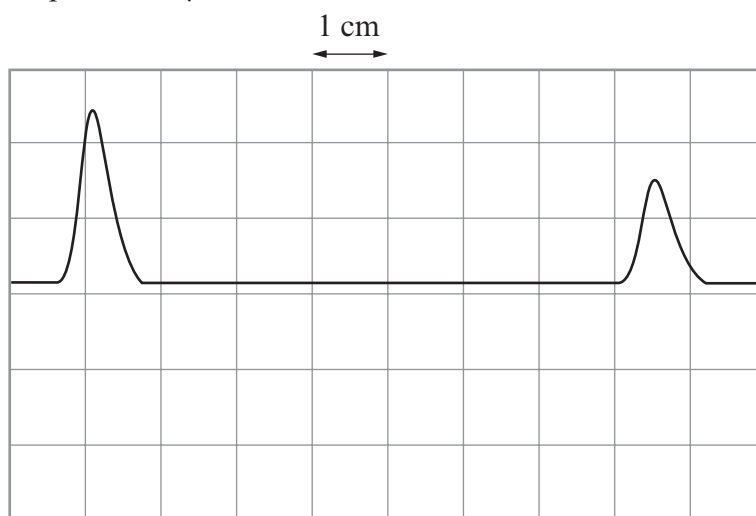

- (I) If the speed of ultrasound in skin and fat is $1.45 \times 10^3 \text{ m s}^{-1}$, calculate the thickness of the layer of skin and fat. [3]

.....

.....

.....

.....

.....

.....



(II) How would the trace on the opposite page change if no gel was placed between the ultrasonic probe and the patient's skin? [1]

.....

.....

(b) (i) X-ray tubes use a hot wire to produce electrons. What happens to the X-ray output if the current to the hot wire increases? Explain your answer. [2]

.....

.....

.....

.....

.....

.....

(ii) An X-ray tube accelerates electrons through a potential difference of 80 kV, giving a **beam** current of 0.45 A. Calculate:

(I) the number of electrons reaching the target every second; [1]

.....

.....

.....

(II) the maximum photon energy of the X-rays produced. [1]

.....

.....

.....

(iii) Computerised axial tomography (CT scans) use a rotating X-ray tube to build up high contrast images of slices through the body. Explain why CT scans are **not** offered for regular checking of healthy patients. [1]

.....

.....

.....



- (c) Electrodes are placed on a healthy patient in order to record the electrical behaviour of the heart. One trace obtained is shown below.

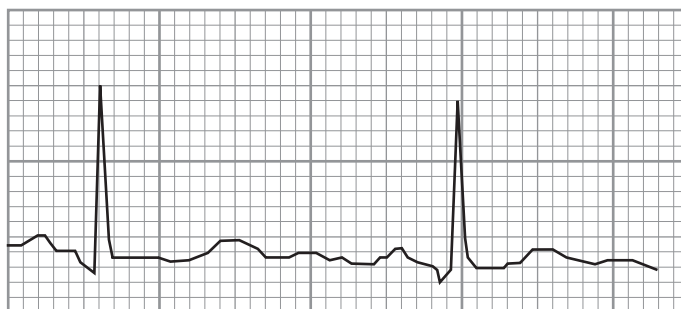

Complete the graph by adding suitable axes, scales and units. [3]

- (d) Explain, briefly, how Magnetic Resonance Imaging (MRI) can produce detailed images of slices through the body. [3]

.....

.....

.....

.....

.....

.....

.....

.....

.....

.....

- (e) When using ionising radiation in medicine the different types of radiation are given a Quality, or Q factor. Do beta particles have a higher, lower or the same Q factor as alpha particles? Explain your answer. [2]

.....

.....

.....

.....

.....

.....

.....

.....



- (b) Show that the efficiency $\frac{Q_1 - Q_2}{Q_1}$ can be written as $1 - \frac{T_2}{T_1}$ for a Carnot cycle. [2]

.....

.....

.....

.....

.....

.....

- (c) Calculate the maximum efficiency of a heat engine operating between 50 °C and 500 °C. [1]

.....

.....

.....

- (d) Coal produces 25 GJ of thermal energy per tonne (1000 kg) and a 35% efficient coal power station produces 3.6 GW of electrical power.

- (i) Calculate the mass of coal burned per second by the power station. [3]

.....

.....

.....

.....

.....

.....



- (ii) Each GJ of energy produced by the power station releases 2.1 kg of pollutants (other than CO₂) into the atmosphere. Calculate the mass of these other pollutants produced by the power station every day. [2]

.....

.....

.....

.....

.....

.....

- (e) In Combined Heat and Power (CHP) stations the waste heat is transferred to hot water pipes for heating nearby houses. The hot water is at a temperature of 80 °C and is transferred in iron pipes of **diameter** 32.0 cm.

- (i) Calculate the total surface area of 90 m of pipes of diameter 32.0 cm. [2]

.....

.....

.....

.....

.....

.....

- (ii) The thermal conductivity of iron is 77 W m⁻¹ K⁻¹, the iron is of thickness 2.54 cm and the temperature of the outside of the iron is 35 °C. Use the thermal conductivity equation to estimate the heat lost per second through the iron pipes. [3]

.....

.....

.....

.....

.....

.....

THE QUESTION CONTINUES ON PAGE 36



(iii) Explain briefly the most appropriate way of reducing the heat losses from the hot iron pipes. [2]

.....

.....

.....

.....

.....

.....





GCE A level

1325/01-B

PHYSICS

ASSESSMENT UNIT PH5

A.M. MONDAY, 18 June 2012

CASE STUDY FOR USE WITH SECTION B

Examination copy

To be given out at the start of the examination.

The pre-release copy must not be used.

1. EXTRASOLAR PLANETS

An EXTRASOLAR PLANET, or EXOPLANET, is a planet outside the Solar System. Astronomers have announced the confirmed detection of more than 500 such planets. Most exoplanets have been detected through radial velocity observations and other indirect methods rather than actual imaging and most of these are giant planets thought to resemble Jupiter. It is now known that a substantial fraction of stars have planetary systems, including at least around 10% of sun-like stars (the true proportion may be much higher). It follows that billions of exoplanets must exist in our own galaxy alone. There are over a thousand planet candidates awaiting confirmation by more detailed investigations, including nearly a hundred that may be in the “Habitable Zone” (see opposite).

2. This planetary habitability chart shows where life might exist on extrasolar planets based on our own solar system and life on Earth. The habitable zone represents the distance from the star where the temperature is not so hot that all the water evaporates and not so cold that all the water freezes.

Graph of Star Mass (relative to our Sun) v Planet Distance from the Star

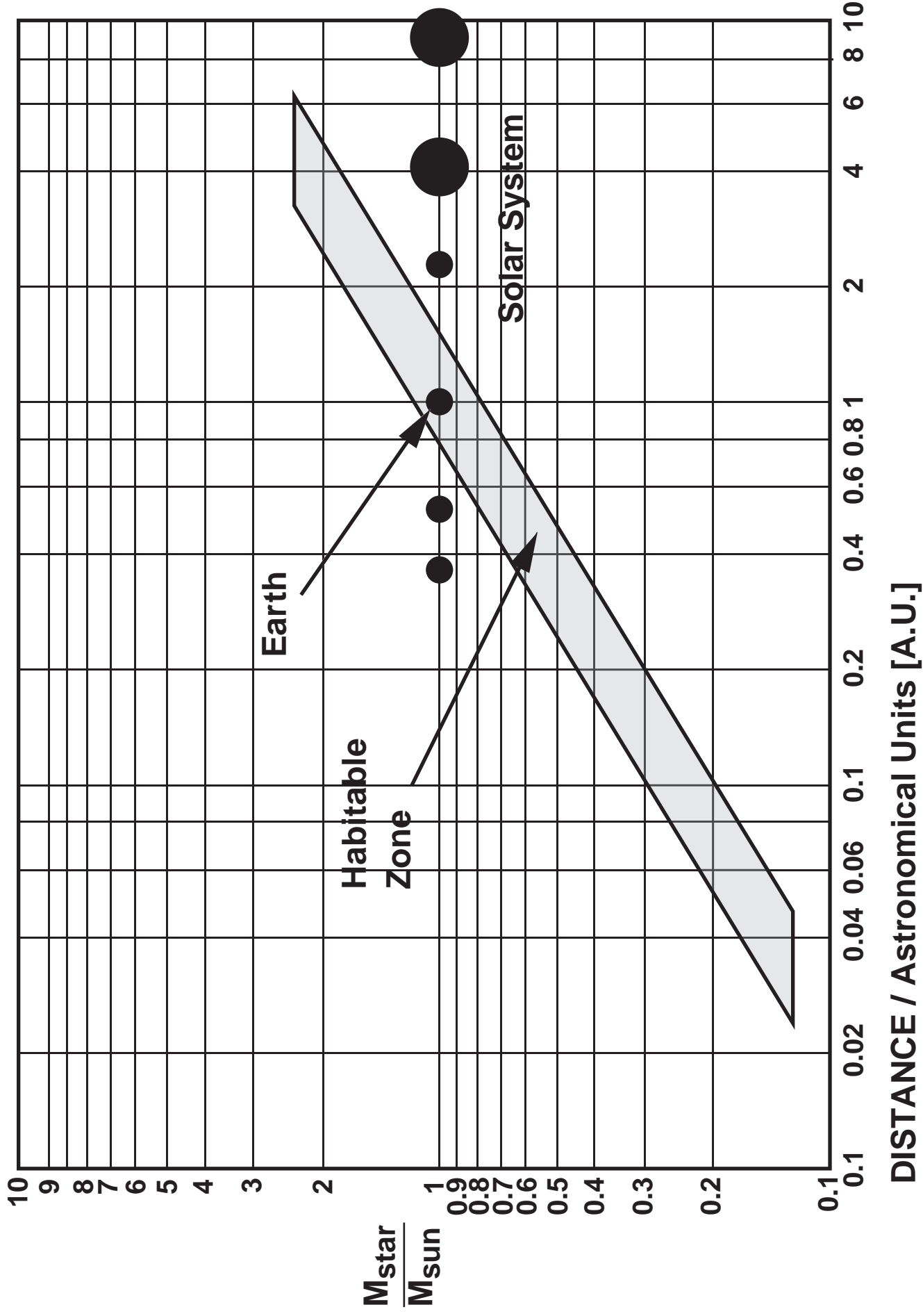

3. HISTORY OF DETECTION

Unconfirmed until 1992, extrasolar planets had long been a subject of discussion and speculation. In the sixteenth century the Italian philosopher Giordano Bruno, an early supporter of the Copernican theory that the Earth and other planets orbit the Sun, put forward the view that the fixed stars are similar to the Sun and are likewise accompanied by their own planets. In the eighteenth century the same possibility was mentioned by Isaac Newton in the “General Scholium” that concludes his PRINCIPIA. Making a comparison with the Sun’s planets, he wrote “And if the fixed stars are the centres of similar systems, they will all be constructed according to a similar design and subject to the dominion of ONE.”

- 4. In early 1992, radio astronomers Aleksander Wolszczan and Dale Frail announced the discovery of planets around a pulsar, PSR 1257+12. This discovery was quickly confirmed, and is generally considered to be the first definitive detection of exoplanets. These pulsar planets are believed to have formed from the unusual remnants of the supernova that produced the pulsar, in a second round of planet formation, or else to be the remaining rocky cores of gas giants that survived the supernova and then decayed into their current orbits.**

5. **On October 6, 1995, Michel Mayor and Didier Queloz of the University of Geneva announced the first definitive detection of an exoplanet orbiting an ordinary main-sequence star (51 Pegasi). This discovery, made at the Observatoire de Haute-Provence, ushered in the modern era of exoplanetary discovery. Technological advances, most notably in high-resolution spectroscopy, led to the detection of many new exoplanets at a rapid rate.**

DETECTION METHODS

6. **Planets are extremely faint compared with their parent stars. At visible wavelengths, they usually have less than a millionth of their parent star's brightness. It is extremely difficult to detect such a faint light source, and furthermore the parent star causes a glare that tends to wash it out. For the above reasons, telescopes have directly imaged no more than about ten exoplanets. This has only been possible for planets that are especially large (usually much larger than Jupiter) and widely separated from their parent star. Most of the directly imaged planets have also been very hot, so that they emit intense infrared radiation; the images have then been made at infrared rather than visible wavelengths, in order to reduce the problem of glare from the parent star.**

At the moment, however, the vast majority of known extrasolar planets have only been detected through indirect methods. The following are the indirect methods that have proven useful:

7. RADIAL VELOCITY OR DOPPLER METHOD

As a planet orbits a star, the star also moves in its own small orbit around the system's centre of mass. Variations in the star's radial velocity – that is, the speed with which it moves towards or away from Earth – can be detected from displacements in the star's spectral lines due to the Doppler effect. Extremely small radial-velocity variations can be observed, down to roughly 1 m s^{-1} . This has been by far the most productive method of discovering exoplanets. It has the advantage of being applicable to stars with a wide range of characteristics.

The Doppler shift of a spectral line is proportional to the orbital velocity of the star and we can use the equation opposite to approximate the orbital velocity of a star (v_s).

8. where M_p is the mass of the exoplanet, M_s is the mass of the star and d is the distance between them (the approximation is that the mass of the star is far greater than the mass of the planet). This equation explains why the Doppler method is most sensitive to large planets which are close to small stars.

$$v_s = M_p \sqrt{\frac{G}{M_s d}}$$

from, $\frac{M_s v_s^2}{r_s} = \frac{GM_s M_p}{d^2}$

and $M_s r_s = M_p d$



centripetal $F =$ gravitational F



approximation of centre of mass equation

9. TRANSIT METHOD

If a planet crosses (or transits) in front of its parent star's disk, then the observed brightness of the star drops by a small amount. The amount by which the star dims depends on its cross-sectional area and on the cross-sectional area of the planet. For instance, the Earth has a radius approximately 100 times less than the Sun, so as it passes in front of the Sun an observer would notice a 0.01% drop in the Sun's apparent intensity. This has been the second most productive method of detection, though it suffers from a substantial rate of false positives (due to the small drop in intensities) and confirmation from another method is usually considered necessary.

10. TRANSIT TIMING VARIATION (TTV)

TTV is an extension of the transit method where the variations in transit of one planet can be used to detect another. The first planetary candidate found this way was exoplanet WASP-3c, using WASP-3b in the WASP-3 system by Rozhen Observatory, Jena Observatory, and Toruń Centre for Astronomy. The new method can potentially detect Earth sized planets or exomoons.

11. GRAVITATIONAL MICROLENSING

Micro lensing occurs when the gravitational field of a star acts like a lens, magnifying the light of a distant background star. Planets orbiting the lensing star can cause detectable anomalies in the magnification as it varies over time. This method has resulted in only a few planetary detections, but it has the advantage of being especially sensitive to planets at large separations from their parent stars.

12. ASTROMETRY

Astrometry consists of precisely measuring a star's position in the sky and observing the changes in that position over time. The motion of a star due to the gravitational influence of a planet may be observable. Because that motion is so small, however, this method has not yet been very productive at detecting exoplanets.

13. PULSAR TIMING

A pulsar (the small, ultradense remnant of a star that has exploded as a supernova) emits radio waves extremely regularly as it rotates. If planets orbit the pulsar, they will cause slight anomalies in the timing of its observed radio pulses. Four planets have been detected in this way, around two different pulsars. The first confirmed discovery of an extrasolar planet was made using this method.

14. TIMING OF ECLIPSING BINARIES

If a planet has a large orbit that carries it around both members of an eclipsing double star system, then the planet can be detected through small variations in the timing of the stars' eclipses of each other. As of December 2009, two planets have been found by this method.

15. CIRCUMSTELLAR DISKS

Disks of space dust surround many stars, and this dust can be detected because it absorbs ordinary starlight and re-emits it as infrared radiation. Features in the disks may suggest the presence of planets.

16. Most extrasolar planet candidates have been found using ground-based telescopes. However, many of the methods can work more effectively with space-based telescopes that avoid atmospheric haze and turbulence. COROT (launched December 2006) and Kepler (launched March 2009) are the two currently active space missions dedicated to searching for extrasolar planets. Hubble Space Telescope and MOST have also found or confirmed a few planets. There are also several planned or proposed space missions geared towards exoplanet observation, such as New Worlds Mission, Darwin, Space Interferometry Mission, Terrestrial Planet Finder and PEGASE.

ORBITAL PARAMETERS

Scatter plot (opposite) showing masses and orbital periods of extrasolar planets discovered.

17. Many exoplanets have orbits with very small radii, and are thus much closer to their parent star than any planet in our own solar system is to the Sun. Astronomers were initially very surprised by these “hot Jupiters”, but it is now clear that most exoplanets (or, at least, most high-mass exoplanets) have much larger orbits, some located in habitable zones - suitable for liquid water and life.

18. MASS DISTRIBUTION

The vast majority of exoplanets detected so far have high masses. Many are considerably more massive than Jupiter, the most massive planet in the Solar System. However, these high masses are in large part due to an observational selection effect: all detection methods are much more likely to discover massive planets. This bias makes statistical analysis difficult, but it appears that lower-mass planets are actually more common than higher-mass ones, at least within a broad mass range that includes all giant planets. In addition, the fact that astronomers have found several planets only a few times more massive than Earth, despite the great difficulty of detecting them, indicates that such planets are fairly common.

19. The results from the first 43 days of the Kepler mission “imply that small candidate planets with periods less than 30 days are much more common than large candidate planets with periods less than 30 days and that the ground-based discoveries are sampling the large-size tail of the size distribution”.

20. TEMPERATURE AND COMPOSITION

It is possible to estimate the temperature of an exoplanet based on the intensity of the light it receives from its parent star. For example, the planet OGLE-2005-BLG-390Lb is estimated to have a surface temperature of roughly -220°C (roughly 50 K). However, such estimates may be substantially in error because factors such as the greenhouse effect may introduce unknown complications. A few planets have had their temperature measured by observing the variation in infrared radiation as the planet moves around in its orbit and is eclipsed by its parent star. For example, the planet HD 189733b has been found to have an average temperature of 1205 ± 9 K ($932\pm 9^{\circ}\text{C}$) on its dayside and 973 ± 33 K ($700\pm 33^{\circ}\text{C}$) on its nightside.

Predicted sizes of different kinds of planets

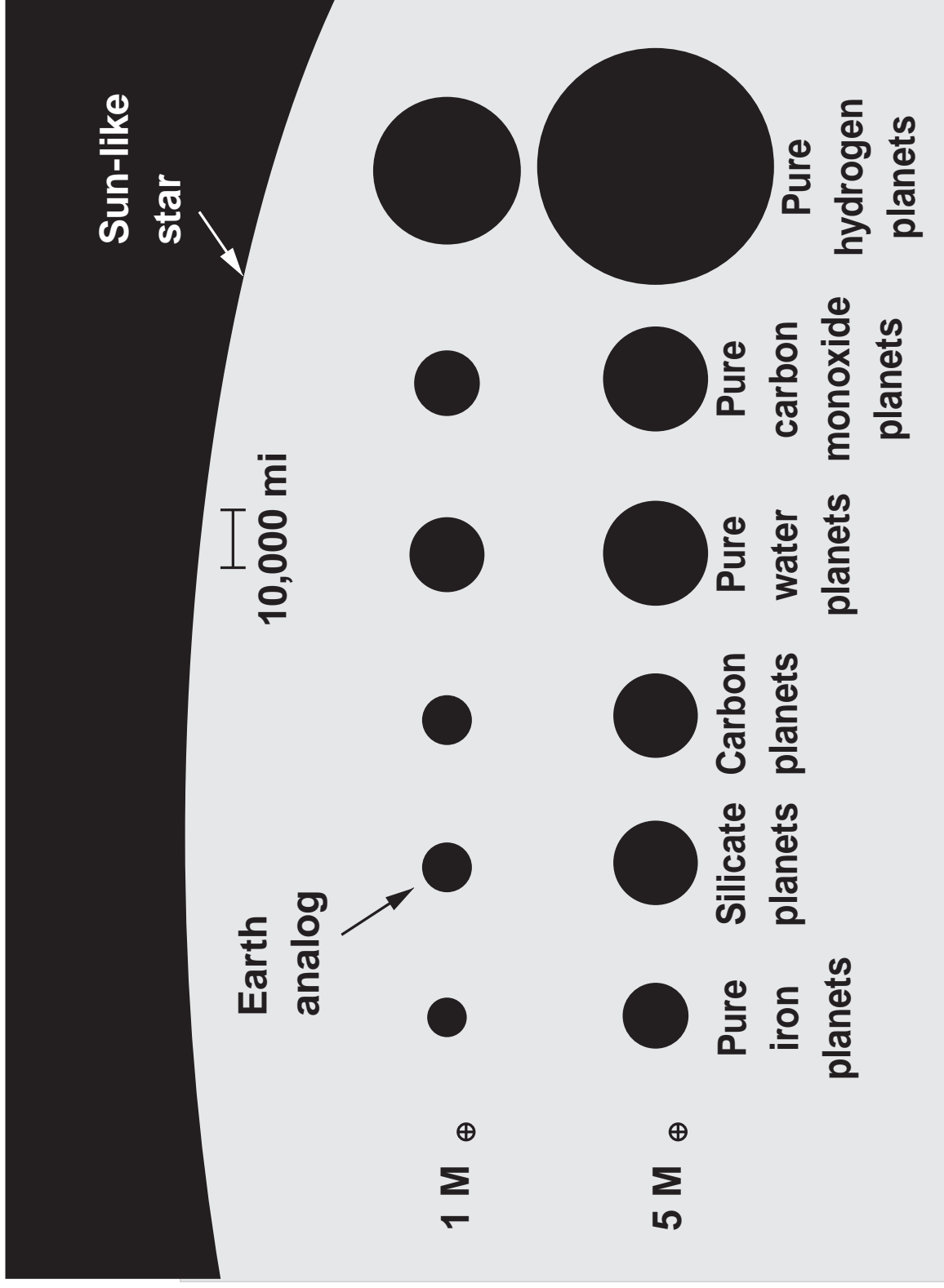

21. If a planet is detectable by both the radial-velocity and the transit methods, then both its true mass and its radius can be found. The planet's density can then be calculated. Planets with low density are inferred to be composed mainly of hydrogen and helium, while planets of intermediate density are inferred to have water as a major constituent. A planet of high density is believed to be rocky, like Earth and the other terrestrial planets of the Solar System.

22. UNANSWERED QUESTIONS

Many unanswered questions remain about the properties of exoplanets. One puzzle is that many transiting exoplanets are much larger than expected given their mass, meaning that they have surprisingly low density. Several theories have been proposed to explain this observation, but none have yet been widely accepted among astronomers. Another question is how likely exoplanets are to possess moons. No such moons have yet been detected, but they may be fairly common.

23. Perhaps the most interesting question about exoplanets is whether they might support life. Several planets do have orbits in their parent star's habitable zone, where it should be possible for liquid water to exist and for Earth-like conditions to prevail. Most of those planets

are giant planets more similar to Jupiter than to Earth; if any of them have large moons, the moons might be a more plausible abode of life. Gliese 581g, thought to be a rocky planet orbiting in the middle of its star's habitable zone, was discovered in September 2010 and, if confirmed, could be the most "Earth-like" planet discovered to date.

24. Various estimates have been made as to how many planets might support simple life or even intelligent life. For example, Dr. Alan Boss of the Carnegie Institution of Science estimates there may be a "hundred billion" terrestrial planets in our Milky Way Galaxy, many with simple life forms. He further believes there could be thousands of civilizations in our galaxy. Recent work by Duncan Forgan of Edinburgh University has also tried to estimate the number of intelligent civilizations in our galaxy. The research suggested there could be thousands of them. Apart from the scenario of an extraterrestrial civilization that is emitting powerful signals, the detection of life at interstellar distances is a tremendously challenging technical task that will not be feasible for many years, even if such life exists.

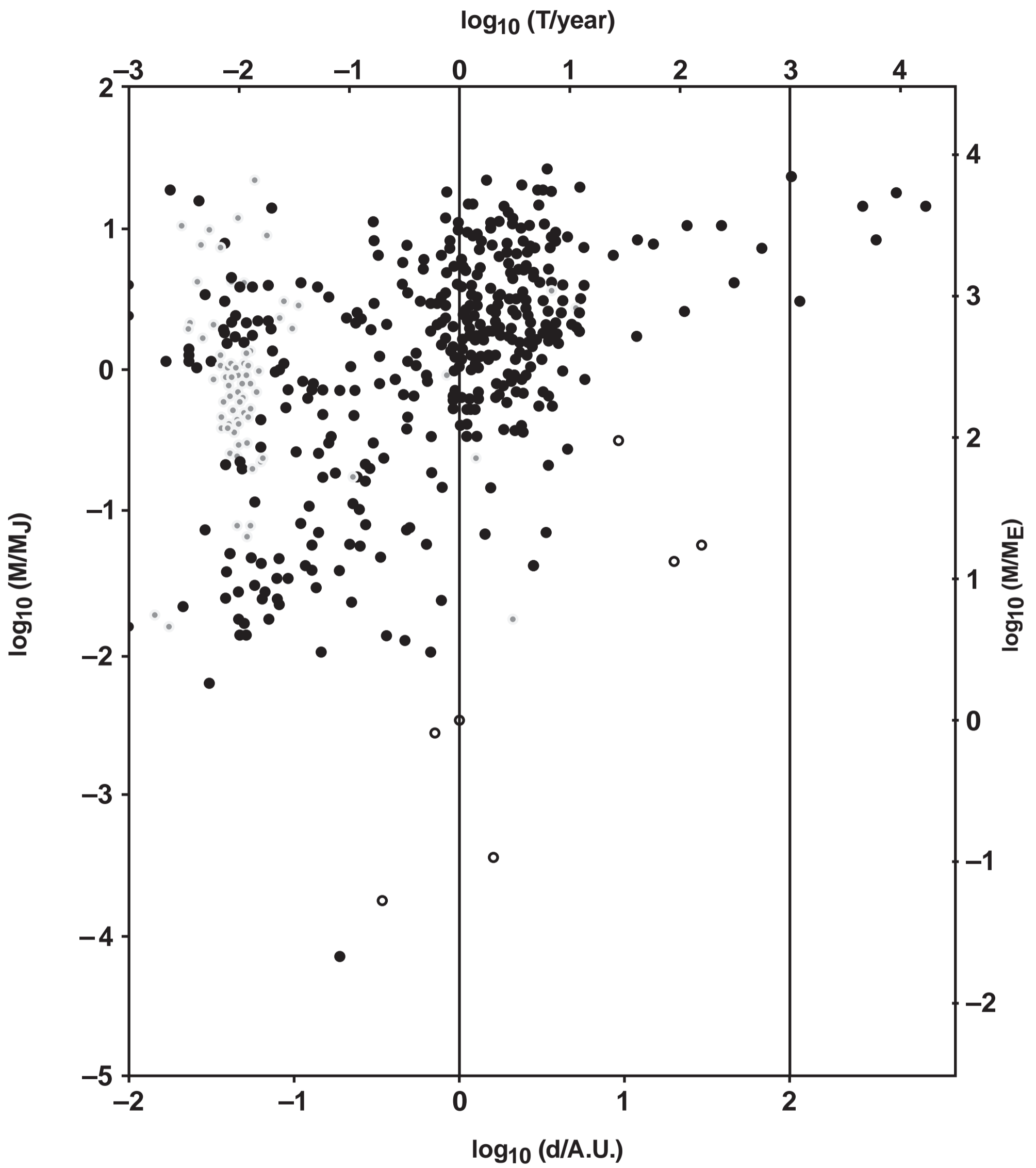



GCE A level

1325/01-B

PHYSICS

ASSESSMENT UNIT PH5

A.M. MONDAY, 18 June 2012

**CASE STUDY FOR USE WITH
SECTION B**

Examination copy

To be given out at the start of the examination.

The pre-release copy must not be used.

1325
01B001

Extrasolar planets

An **extrasolar planet**, or **exoplanet**, is a planet outside the Solar System. Astronomers have announced the confirmed detection of more than 500 such planets. Most exoplanets have been detected through radial velocity observations and other indirect methods rather than actual imaging and most of these are giant planets thought to resemble Jupiter. It is now known that a substantial fraction of stars have planetary systems, including at least around 10% of sun-like stars (the true proportion may be much higher). It follows that billions of exoplanets must exist in our own galaxy alone. There are over a thousand planet candidates awaiting confirmation by more detailed investigations, including nearly a hundred that may be in the “Habitable Zone” (see below).

Graph of Star Mass (relative to our Sun) v Planet Distance from the Star

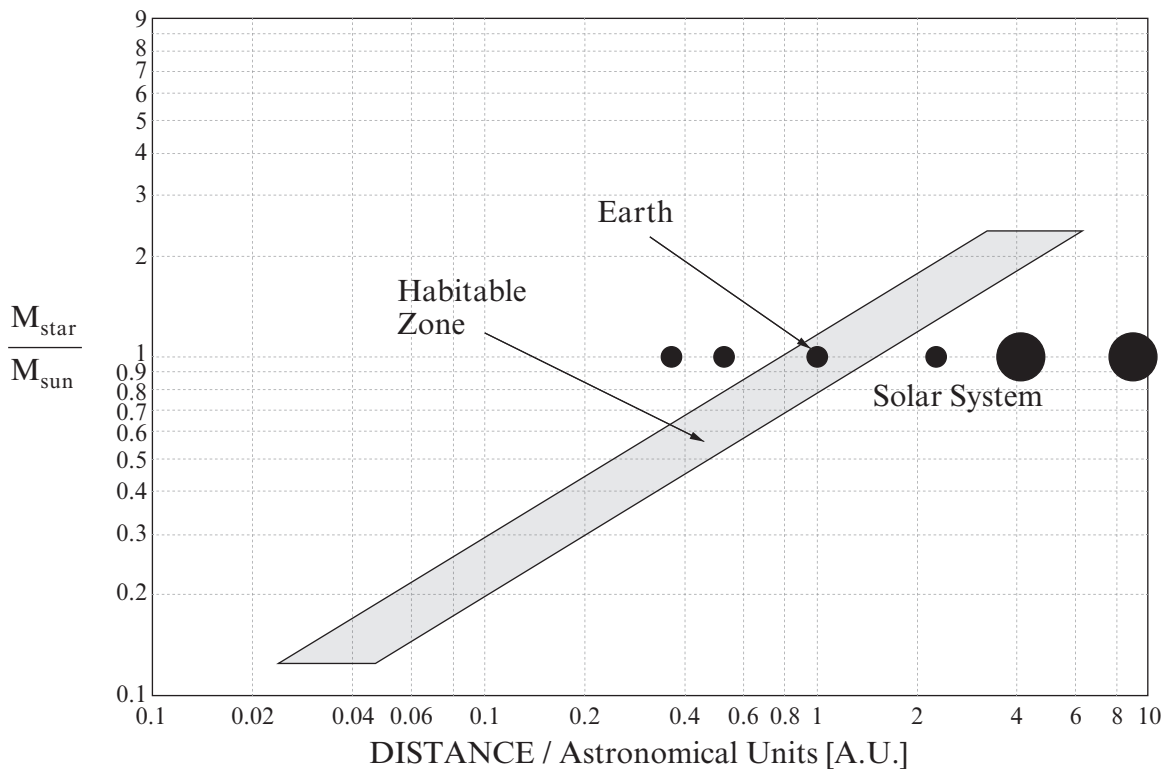

This planetary habitability chart shows where life might exist on extrasolar planets based on our own solar system and life on Earth. The habitable zone represents the distance from the star where the temperature is not so hot that all the water evaporates and not so cold that all the water freezes.

History of detection

Unconfirmed until 1992, extrasolar planets had long been a subject of discussion and speculation. In the sixteenth century the Italian philosopher Giordano Bruno, an early supporter of the Copernican theory that the Earth and other planets orbit the Sun, put forward the view that the fixed stars are similar to the Sun and are likewise accompanied by their own planets. In the eighteenth century the same possibility was mentioned by Isaac Newton in the “General Scholium” that concludes his *Principia*. Making a comparison with the Sun’s planets, he wrote “And if the fixed stars are the centres of similar systems, they will all be constructed according to a similar design and subject to the dominion of *One*.”

In early 1992, radio astronomers Aleksander Wolszczan and Dale Frail announced the discovery of planets around a pulsar, PSR 1257+12. This discovery was quickly confirmed, and is generally considered to be the first definitive detection of exoplanets. These pulsar planets are believed to have formed from the unusual remnants of the supernova that produced the pulsar, in a second round of planet formation, or else to be the remaining rocky cores of gas giants that survived the supernova and then decayed into their current orbits.

On October 6, 1995, Michel Mayor and Didier Queloz of the University of Geneva announced the first definitive detection of an exoplanet orbiting an ordinary main-sequence star (51 Pegasi). This discovery, made at the Observatoire de Haute-Provence, ushered in the modern era of exoplanetary discovery. Technological advances, most notably in high-resolution spectroscopy, led to the detection of many new exoplanets at a rapid rate.

Detection methods

Planets are extremely faint compared with their parent stars. At visible wavelengths, they usually have less than a millionth of their parent star's brightness. It is extremely difficult to detect such a faint light source, and furthermore the parent star causes a glare that tends to wash it out.

For the above reasons, telescopes have directly imaged no more than about ten exoplanets. This has only been possible for planets that are especially large (usually much larger than Jupiter) and widely separated from their parent star. Most of the directly imaged planets have also been very hot, so that they emit intense infrared radiation; the images have then been made at infrared rather than visible wavelengths, in order to reduce the problem of glare from the parent star.

At the moment, however, the vast majority of known extrasolar planets have only been detected through indirect methods. The following are the indirect methods that have proven useful:

- **Radial velocity or Doppler method**

As a planet orbits a star, the star also moves in its own small orbit around the system's centre of mass. Variations in the star's radial velocity – that is, the speed with which it moves towards or away from Earth – can be detected from displacements in the star's spectral lines due to the Doppler effect. Extremely small radial-velocity variations can be observed, down to roughly 1 m s^{-1} . This has been by far the most productive method of discovering exoplanets. It has the advantage of being applicable to stars with a wide range of characteristics.

The Doppler shift of a spectral line is proportional to the orbital velocity of the star and we can use the following equation to approximate the orbital velocity of a star (v_s).

$$v_s = M_p \sqrt{\frac{G}{M_s d}}$$

from, $\frac{M_s v_s^2}{r_s} = \frac{GM_s M_p}{d^2}$	and	$M_s r_s = M_p d$
\uparrow centripetal $F =$ gravitational F		\uparrow approximation of centre of mass equation

where M_p is the mass of the exoplanet, M_s is the mass of the star and d is the distance between them (the approximation is that the mass of the star is far greater than the mass of the planet). This equation explains why the Doppler method is most sensitive to large planets which are close to small stars.

Transit method

If a planet crosses (or transits) in front of its parent star's disk, then the observed brightness of the star drops by a small amount. The amount by which the star dims depends on its cross-sectional area and on the cross-sectional area of the planet. For instance, the Earth has a radius approximately 100 times less than the Sun, so as it passes in front of the Sun an observer would notice a 0.01% drop in the Sun's apparent intensity. This has been the second most productive method of detection, though it suffers from a substantial rate of false positives (due to the small drop in intensities) and confirmation from another method is usually considered necessary.

- **Transit Timing Variation (TTV)**

TTV is an extension of the transit method where the variations in transit of one planet can be used to detect another. The first planetary candidate found this way was exoplanet WASP-3c, using WASP-3b in the WASP-3 system by Rozhen Observatory, Jena Observatory, and Toruń Centre for Astronomy. The new method can potentially detect Earth sized planets or exomoons.

- **Gravitational microlensing**

Microlensing occurs when the gravitational field of a star acts like a lens, magnifying the light of a distant background star. Planets orbiting the lensing star can cause detectable anomalies in the magnification as it varies over time. This method has resulted in only a few planetary detections, but it has the advantage of being especially sensitive to planets at large separations from their parent stars.

- **Astrometry**

Astrometry consists of precisely measuring a star's position in the sky and observing the changes in that position over time. The motion of a star due to the gravitational influence of a planet may be observable. Because that motion is so small, however, this method has not yet been very productive at detecting exoplanets.

- **Pulsar timing**

A pulsar (the small, ultradense remnant of a star that has exploded as a supernova) emits radio waves extremely regularly as it rotates. If planets orbit the pulsar, they will cause slight anomalies in the timing of its observed radio pulses. Four planets have been detected in this way, around two different pulsars. The first confirmed discovery of an extrasolar planet was made using this method.

- **Timing of eclipsing binaries**

If a planet has a large orbit that carries it around both members of an eclipsing double star system, then the planet can be detected through small variations in the timing of the stars' eclipses of each other. As of December 2009, two planets have been found by this method.

- **Circumstellar disks**

Disks of space dust surround many stars, and this dust can be detected because it absorbs ordinary starlight and re-emits it as infrared radiation. Features in the disks may suggest the presence of planets.

Most extrasolar planet candidates have been found using ground-based telescopes. However, many of the methods can work more effectively with space-based telescopes that avoid atmospheric haze and turbulence. COROT (launched December 2006) and Kepler (launched March 2009) are the two currently active space missions dedicated to searching for extrasolar planets. Hubble Space Telescope and MOST have also found or confirmed a few planets. There are also several planned or proposed space missions geared towards exoplanet observation, such as New Worlds Mission, Darwin, Space Interferometry Mission, Terrestrial Planet Finder and PEGASE.

Orbital parameters

Scatter plot showing masses and orbital periods of extrasolar planets discovered.

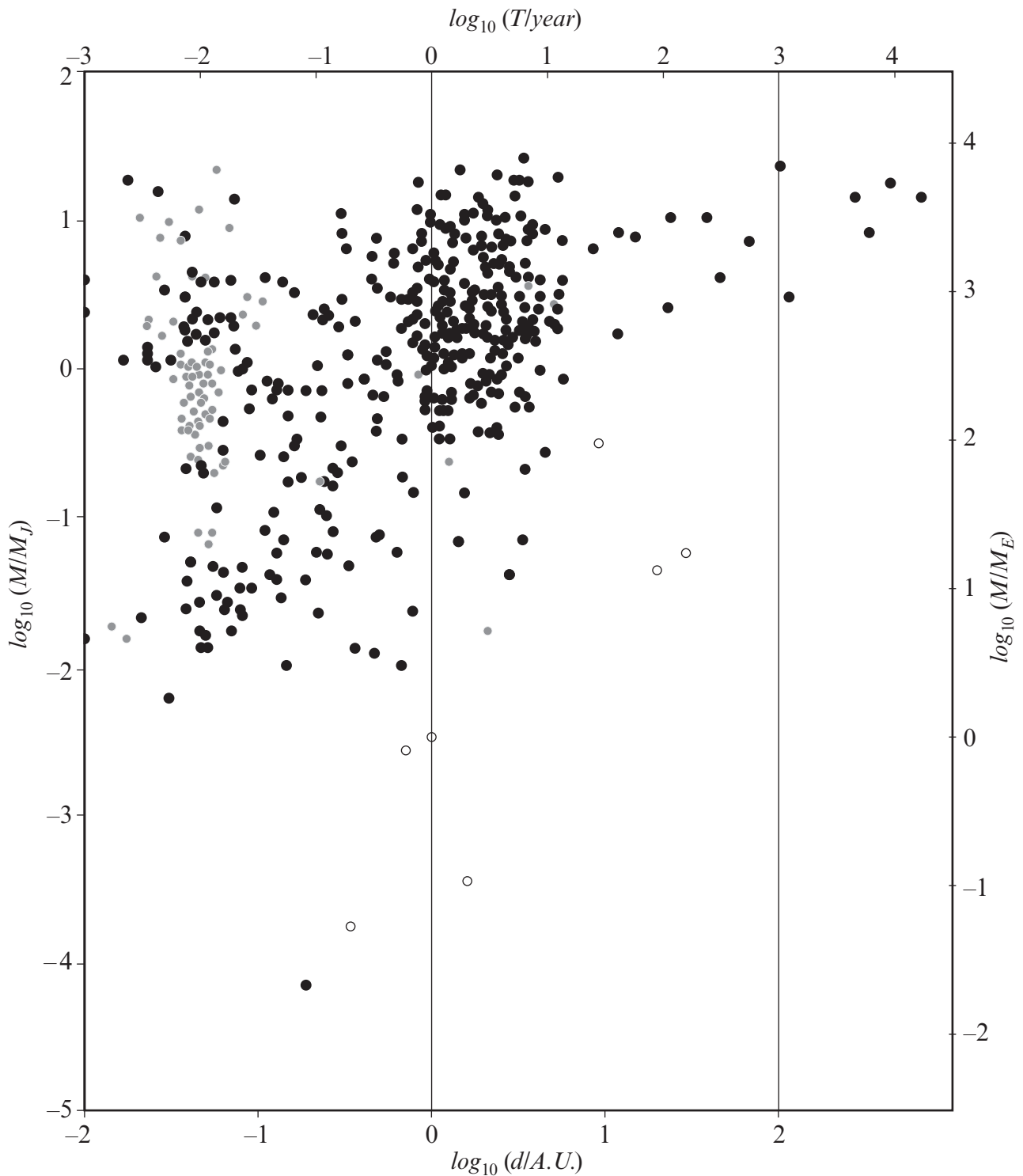

Many exoplanets have orbits with very small radii, and are thus much closer to their parent star than any planet in our own solar system is to the Sun. Astronomers were initially very surprised by these “hot Jupiters”, but it is now clear that most exoplanets (or, at least, most high-mass ¹⁷ exoplanets) have much larger orbits, some located in habitable zones - suitable for liquid water and life.

Mass distribution

The vast majority of exoplanets detected so far have high masses. Many are considerably more massive than Jupiter, the most massive planet in the Solar System. However, these high masses are in large part due to an observational selection effect: all detection methods are much more likely to discover massive planets. This bias makes statistical analysis difficult, but it appears that lower-mass planets are actually more common than higher-mass ones, at least within a broad mass range that includes all giant planets. In addition, the fact that astronomers have found several planets only a few times more massive than Earth, despite the great difficulty of detecting them, indicates that such planets are fairly common.

The results from the first 43 days of the Kepler mission “imply that small candidate planets with periods less than 30 days are much more common than large candidate planets with periods less than 30 days and that the ground-based discoveries are sampling the large-size tail of the size distribution”.

Temperature and composition

It is possible to estimate the temperature of an exoplanet based on the intensity of the light it receives from its parent star. For example, the planet OGLE-2005-BLG-390Lb is estimated to have a surface temperature of roughly -220°C (roughly 50 K). However, such estimates may be substantially in error because factors such as the greenhouse effect may introduce unknown complications. A few planets have had their temperature measured by observing the variation in infrared radiation as the planet moves around in its orbit and is eclipsed by its parent star. For example, the planet HD 189733b has been found to have an average temperature of 1205 ± 9 K ($932 \pm 9^{\circ}\text{C}$) on its dayside and 973 ± 33 K ($700 \pm 33^{\circ}\text{C}$) on its nightside.

If a planet is detectable by both the radial-velocity and the transit methods, then both its true mass and its radius can be found. The planet’s density can then be calculated. Planets with low density are inferred to be composed mainly of hydrogen and helium, while planets of intermediate density are inferred to have water as a major constituent. A planet of high density is believed to be rocky, like Earth and the other terrestrial planets of the Solar System.

Unanswered questions

Many unanswered questions remain about the properties of exoplanets. One puzzle is that many transiting exoplanets are much larger than expected given their mass, meaning that they have surprisingly low density. Several theories have been proposed to explain this observation, but none have yet been widely accepted among astronomers. Another question is how likely exoplanets are to possess moons. No such moons have yet been detected, but they may be fairly common.

Perhaps the most interesting question about exoplanets is whether they might support life. Several planets do have orbits in their parent star’s habitable zone, where it should be possible for liquid water to exist and for Earth-like conditions to prevail. Most of those planets are giant planets more similar to Jupiter than to Earth; if any of them have large moons, the moons might be a more plausible abode of life. Gliese 581g, thought to be a rocky planet orbiting in the middle of its star’s habitable zone, was discovered in September 2010 and, if confirmed, could be the most “Earth-like” planet discovered to date.

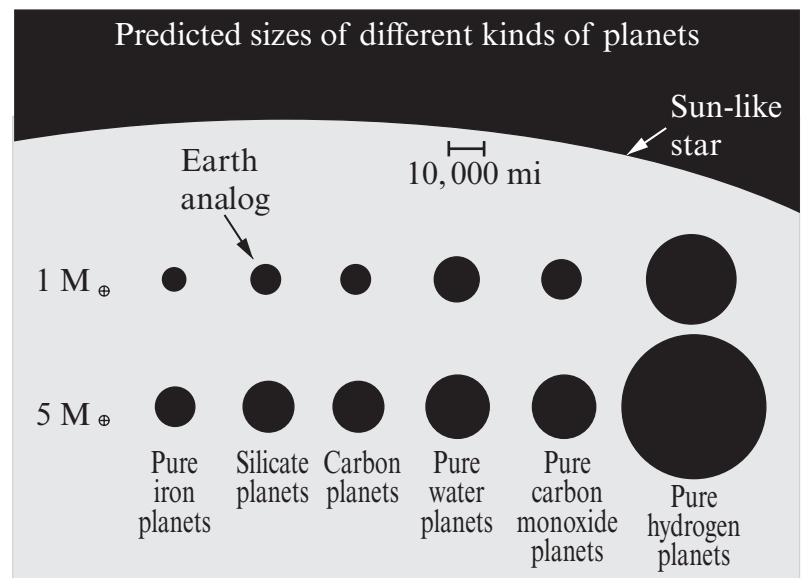

Various estimates have been made as to how many planets might support simple life or even intelligent life. For example, Dr. Alan Boss of the Carnegie Institution of Science estimates there may be a “hundred billion” terrestrial planets in our Milky Way Galaxy, many with simple life forms. He further believes there could be thousands of civilizations in our galaxy. Recent work by Duncan Forgan of Edinburgh University has also tried to estimate the number of intelligent 24 civilizations in our galaxy. The research suggested there could be thousands of them. Apart from the scenario of an extraterrestrial civilization that is emitting powerful signals, the detection of life at interstellar distances is a tremendously challenging technical task that will not be feasible for many years, even if such life exists.

Sources:

page 5 - http://en.wikipedia.org/wiki/File:Exoplanet_Period-Mass_Scatter.png

page 6 - http://en.wikipedia.org/wiki/File:Planet_sizes.svg