

**ADVANCED SUBSIDIARY GCE
PHYSICS B (ADVANCING PHYSICS)**

G492

Unit G492: Understanding Processes /
Experimentation and Data Handling

ADVANCE NOTICE

**Monday 17 January 2011
Afternoon**

Duration: 2 hours



INSTRUCTIONS TO CANDIDATES

- Take the article away and read through it carefully. Spend some time looking up any technical terms or phrases you do not understand. You are **not** required to research further the particular topic described in part 3, although you might find it helpful to try out the measurement ideas described in part 2.
- For the examination on Monday 17 January 2011 you will be given a fresh copy of this article, together with a question paper. You will not be able to take your original copy into the examination with you.
- The values of standard physical constants will be given in the Advancing Physics Data, Formulae and Relationships booklet. Any additional data required are given in the appropriate question.

INFORMATION FOR CANDIDATES

- Questions in Section C of paper G492 (Understanding Processes, Experimentation and Data Handling) will refer to this Advance Notice material and may give additional data related to it.
- Section C will be worth about 40 marks.
- Sections A and B of paper G492 will be worth about 60 marks, and will examine the *Understanding Processes* section of the specification.
- This document consists of **8** pages. Any blank pages are indicated.

1. Uncertainty, range bars and best-fit lines

When you plot data on a graph, it is useful to be able to show the uncertainties in the values. If a best-fit line or curve is to be drawn, the size of the range bars gives a good indication how close the line ought to go to the points in question.

As an example, look at the graph of Fig. 1, showing the kinetic energy gained by a falling object after dropping through a height h .

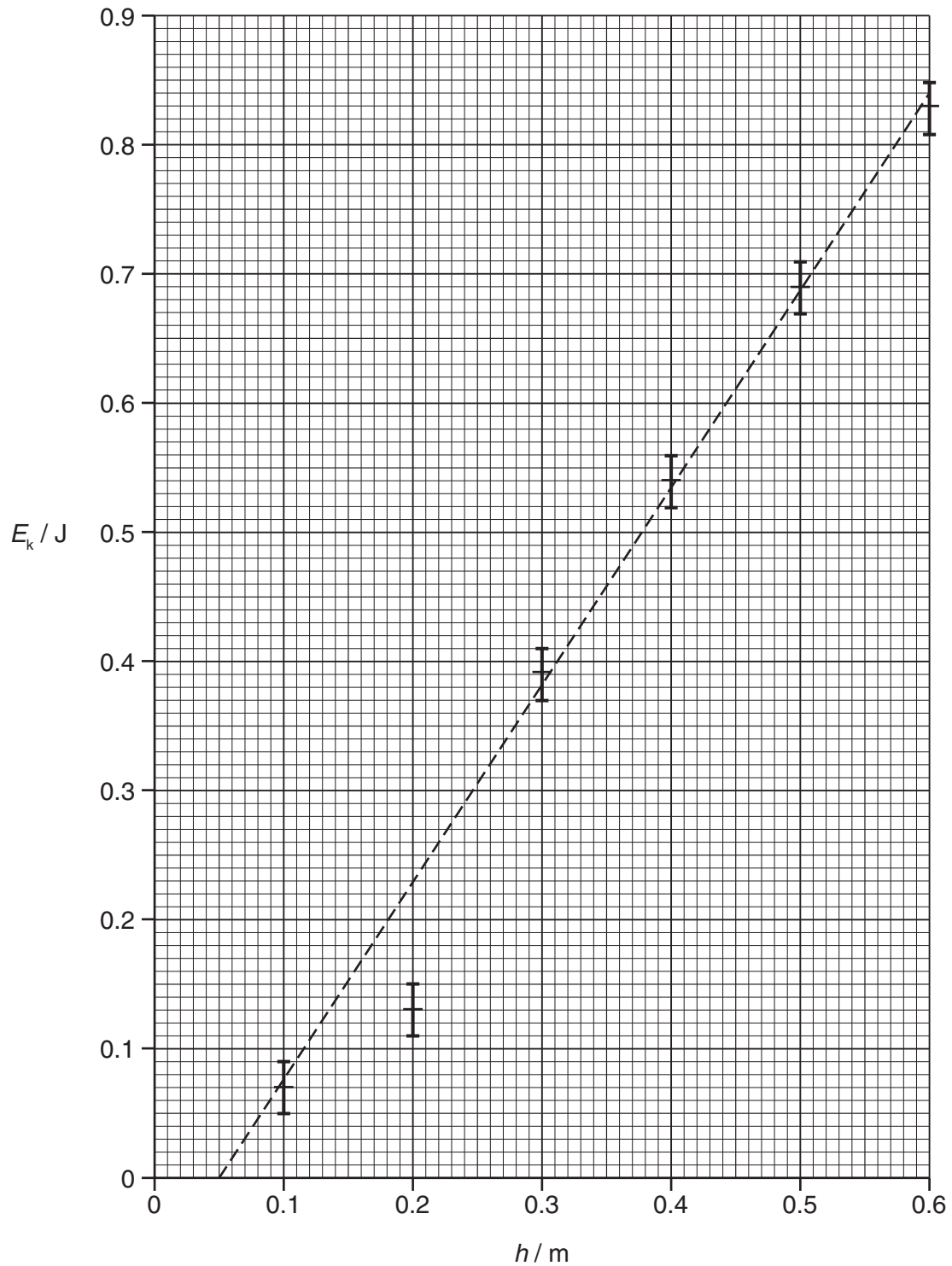

Fig. 1

3

The graph seems linear, but it has a point at $h = 0.2\text{m}$, $E_k = 0.13\text{J}$ which is further than its estimated uncertainty from any straight line which could be drawn through the range bars of all the other points. This seems to be an outlier, and has been omitted in drawing the best-fit straight line shown.

Another problem is that the line would be expected to go through the origin, but this one clearly does not, even if the outlier is ignored. This may involve a systematic error in measurement of initial height or final velocity, or it may indicate energy losses. Deciding which is responsible will involve looking in detail at the experimental procedure used.

2. Young's Double-Slit Experiment

Historically, the first really serious challenge to Newton's particle theory of light was made by Thomas Young. Young knew that sound was a wave and displayed a phenomenon called *interference*. He reasoned that if light were actually a wave phenomenon, as he suspected, then a similar interference effect should also be observed for light. He observed exactly the effect he predicted.

One popular classroom arrangement for observing what Young discovered is shown in Fig. 2.

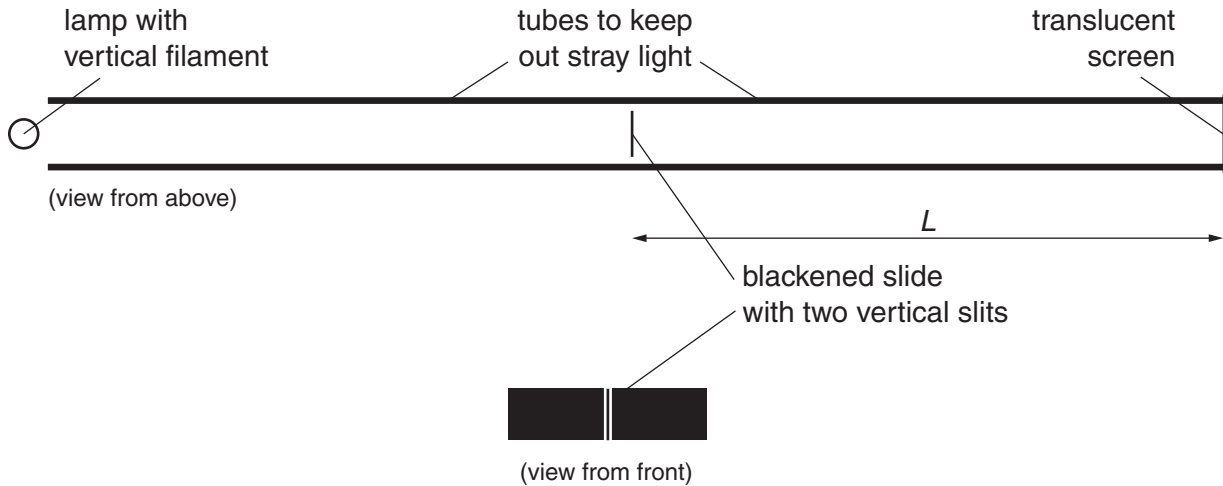

Fig. 2

The light from the filament of the lamp is incident on the blackened slide. This is a microscope slide blackened with graphite paint, with two slits scratched through the paint very close together. Each slit, scratched with a fine needle, is a fraction of a millimetre wide and the distance d between the centres of the two slits needs to be less than 1 mm. The interference fringes (maxima and minima) are viewed on a screen a distance L from the two slits as shown in Fig. 3, and are seen to be at a constant spacing x .

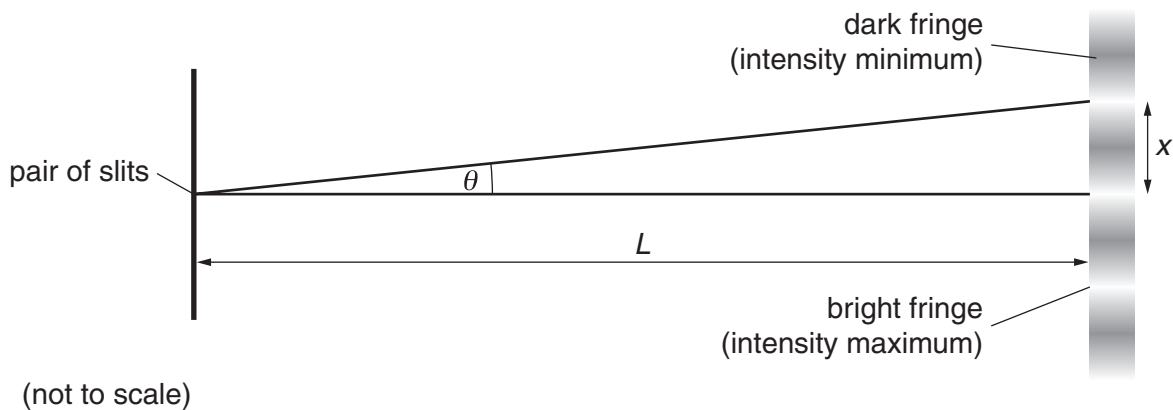

Fig. 3

The difference between the paths from the two slits to the first bright fringe from the centre is one wavelength. Fig. 4 shows that $\lambda = d \sin \theta$ where d is the separation between the centres of the two slits.

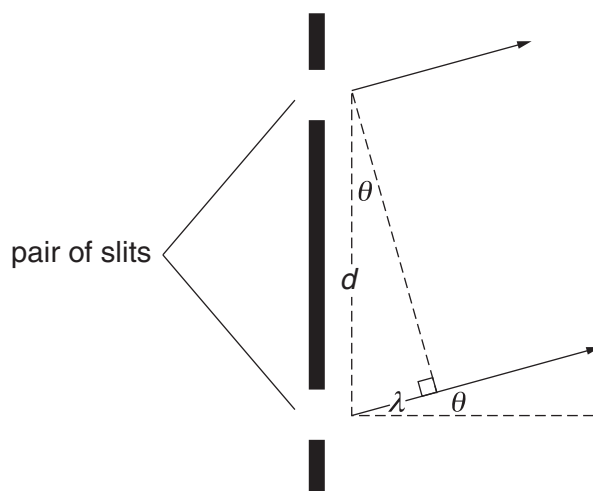

Fig. 4

To a very good approximation, $\sin \theta = \frac{x}{L}$ for the values of x and L met in this experiment, so that $\lambda = \frac{dx}{L}$.

The separation d between the centres of the two slits is extremely hard to measure accurately. A travelling microscope – sometimes called a vernier microscope – allows measurement of separations to ± 0.01 mm. A larger value of the slit separation d reduces the percentage uncertainty in this measurement but makes it harder to measure the fringe separation x .

The fringes seen on the translucent screen are fuzzy, but it is possible to see about seven maxima. Measurement of the fringe separation x is difficult, because x is quite small, and it is difficult to see the middle of each bright fringe. Furthermore, the different colours in the white light from the filament lamp produce fringes of slightly different spacing, so that the maxima become broader and coloured at the edges as you move out from the centre. This problem can be reduced by using coloured filters, but this does make the faint fringes even fainter.

3. Tycho Brahe: pushing the bounds of measurement

An important measurement made by astronomers is the altitude of a star or planet when it passes due south of the observer. By recording this angle together with the exact time it occurs, maps of the heavens can be drawn. This observation can be done with the naked eye, but it needs a large quadrant (a protractor or angle measurer) to give readings to a precision better than 1° .

In the sixteenth century, before the invention of telescopes, the Danish nobleman and astronomer Tycho Brahe made famous measurements of the shifting positions of the planets.

He used a very large brass quadrant 2.0 m in radius, built into a wall. The wall was aligned north-south, and the centre of the quadrant was a narrow slit in the facing wall (Fig. 5).

The quadrant had two parallel scales with divisions of 10 arc-minutes (sixths of a degree) nearly 6 mm apart, with diagonal lines of nine dots between these markings as shown in Fig. 5 to allow the instrument to be read to the nearest minute of arc ($1' = \frac{1}{60}^\circ$).

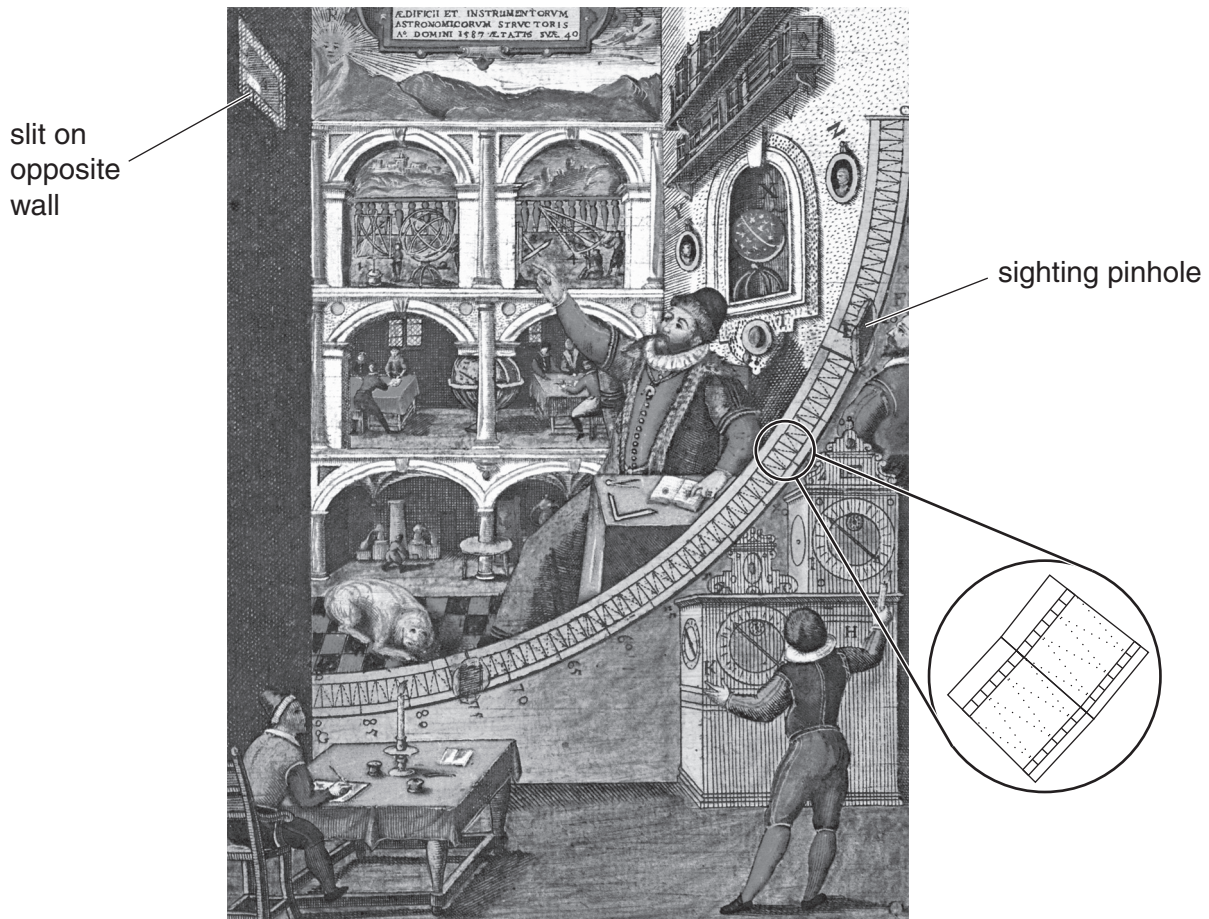

Fig. 5

The observer would line up the sighting pinhole on the star or planet, seen through the slit in the opposite wall, and then find the angle by counting along the line of dots to find how many minutes of arc to add to the main scale reading.

Brahe also improved the sighting pinhole. The observer had to put his eye close to the pinhole to be able to see the star or planet, and slight movements of the observer's head would be possible while still keeping the object in view. This introduces an uncertainty, known as parallax, of eight arc-minutes ($\pm 0.13^\circ$).

Brahe found that using two pinholes, one on each side of the quadrant scale, reduced this uncertainty to about one arc-minute ($\pm 0.017^\circ$). The two pinholes were mounted on the **cursor**, a moveable straight-edge used to take the reading from the quadrant scale. When the pinholes were aligned with the star or planet, the number of dots between the last scale division and the cursor were counted to give the number of minutes of arc to add to that scale reading. In Fig. 6 below, the angle would be $41^\circ + (2 \times 10') + 6' = 41^\circ 26' = 41.43^\circ$.

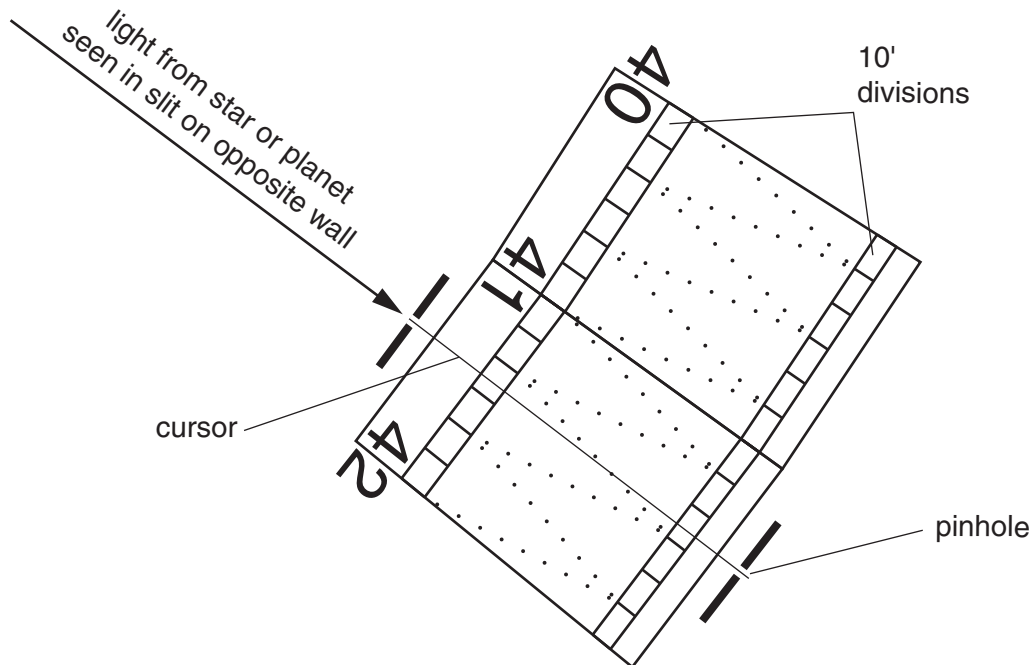

Fig. 6

Brahe checked on this instrument itself by comparison with other quadrants he had built, and repeatedly calibrated his instruments by measuring the positions of fixed stars, which do not change their positions in the sky the way that planets do. He also introduced an idea which is now fundamental to all experimental science: he repeated his readings, which improved his confidence in the angles obtained. So good were Brahe's readings that, some years later, the astronomer Kepler used them to deduce the way in which planets move.

The advances in measurement made by Tycho Brahe were not without cost. It has been estimated that getting the King of Denmark to finance the building of his great observatory cost 1% of the entire Danish state budget. In comparison, the UK's share of costs in the LHC (Large Hadron Collider), one of the most costly modern scientific developments, is about 0.003% of the UK's state budget. Many people feel that the money spent on the LHC would be better spent elsewhere; this simple comparison suggests that Brahe's observatory was 300 times more expensive!

END OF ARTICLE

**Copyright Information**

OCR is committed to seeking permission to reproduce all third-party content that it uses in its assessment materials. OCR has attempted to identify and contact all copyright holders whose work is used in this paper. To avoid the issue of disclosure of answer-related information to candidates, all copyright acknowledgements are reproduced in the OCR Copyright Acknowledgements Booklet. This is produced for each series of examinations and is freely available to download from our public website (www.ocr.org.uk) after the live examination series.

If OCR has unwittingly failed to correctly acknowledge or clear any third-party content in this assessment material, OCR will be happy to correct its mistake at the earliest possible opportunity.

For queries or further information please contact the Copyright Team, First Floor, 9 Hills Road, Cambridge CB2 1GE.

OCR is part of the Cambridge Assessment Group; Cambridge Assessment is the brand name of University of Cambridge Local Examinations Syndicate (UCLES), which is itself a department of the University of Cambridge.