



**ADVANCED SUBSIDIARY GCE  
PHYSICS B (ADVANCING PHYSICS)**

**G492**

Unit G492: Understanding Processes /  
Experimentation and Data Handling

**INSERT**

**Wednesday 13 January 2010  
Morning**

**Duration: 2 hours**



**INSTRUCTIONS TO CANDIDATES**

- This insert contains the article required to answer the questions in Section C.

**INFORMATION FOR CANDIDATES**

- This document consists of **8** pages. Any blank pages are indicated.

## 1 Calibration of instruments

Sensor circuits usually need calibration before they can be used to make measurements. This involves measuring the output for different values of the input variable.

Measurements using the thermistor circuit Fig. 1 as a temperature sensor give the graphs shown in Fig. 2, showing the three calibration graphs obtained when the fixed resistor has the values  $500\ \Omega$ ,  $5000\ \Omega$  and  $50\ 000\ \Omega$  respectively.

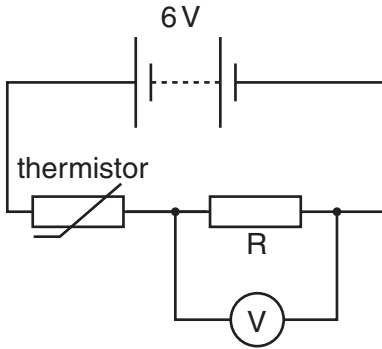

Fig. 1

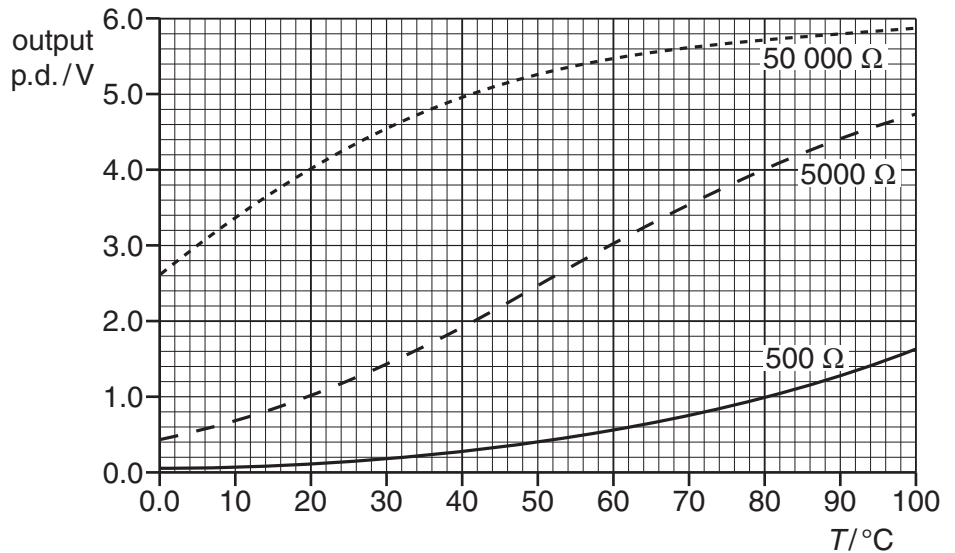

Fig. 2

The three calibration graphs show that using different values of fixed resistor changes the **sensitivity** of the circuit at different points of the temperature range, and affects the **linearity** of the relationship between input and output. The **range** of output values obtained is also different in each case, which affects the **resolution** of the circuit.

## 2 Spectacles for the Third World

Many charities collect unwanted spectacle lenses for reuse in the Third World. The power of these lenses varies from +5D (converging) to -5D (diverging), with the majority being in the latter category. There is a need for a quick and easy-to-use method of measuring the power of these lenses when they arrive at their destination, using appropriate technology and expertise.

Measurement of the power of a converging lens is fairly straightforward. All you need is a beam of parallel light, a piece of stiff white card and a ruler, as shown in Fig. 3.

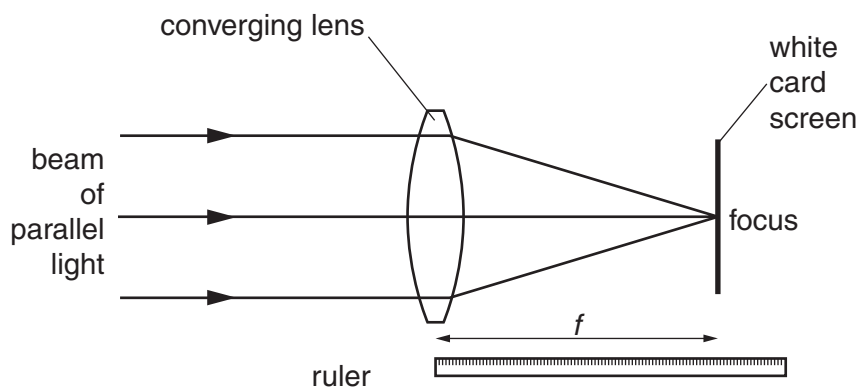

Fig. 3

This method does not work for a diverging lens. This is because the light which leaves the lens appears to come from a point behind it, where you cannot put a screen to find the focus, as shown in Fig. 4.

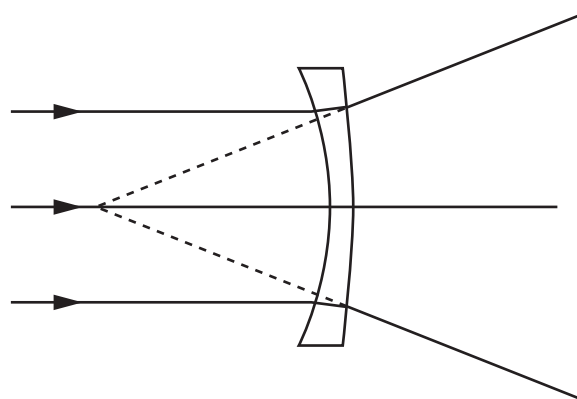

Fig. 4

The way that a diverging lens *can* be made to focus light to a point on a screen is to use a converging lens to arrange for the incoming light beam to be already aiming to a focus, as shown in Fig. 5.

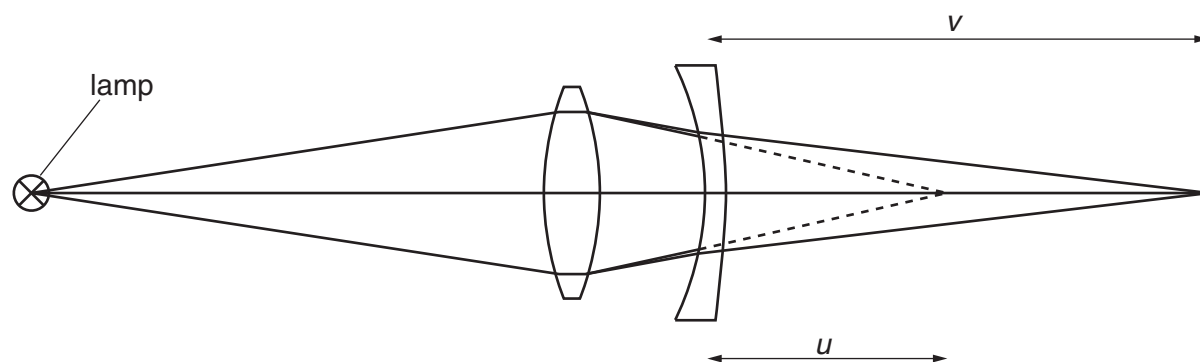

Fig. 5

A charity appoints an engineer to design a simple method for use in the Third World to measure the power of diverging spectacle lenses. She uses the arrangement shown in Fig. 5 and follows this procedure:

- With both lenses in place, measure the distance from the diverging lens to the position of the screen where the light is focused. This is the image distance,  $v$ .
- Remove the diverging lens, and move the screen until the light is focused by the converging lens alone. The distance from where the diverging lens was placed to the new screen position is the object distance,  $u$ .

The power  $P$  of the diverging lens is calculated from the formula  $P = \frac{1}{v} - \frac{1}{u}$ , where both the image distance  $v$  and the object distance  $u$  are **positive** because they are to the right of the lens.

The table gives a set of measurements obtained by this method. Different pairs of values of  $u$  and  $v$  are obtained by changing the distance from the lamp to the converging lens.

$u/\text{cm}$	10	11	12	13	14	15
$v/\text{cm}$	17	21	24	29	36	42

### 3 Performance of commercial jet aircraft

Although much criticised for their carbon footprint, modern jet aircraft have been developed to carry the largest load they can, at the greatest speed possible, for the smallest amount of fuel. This is basic economic good sense. However, some of these factors do compete with each other: the fastest commercial jet aircraft, Concorde, proved uneconomic to run, as it could not carry enough passengers to make its journeys profitable. It was taken out of service in 2003.

#### Weight and range

More recent jet aircraft are designed to carry many more passengers and their luggage than Concorde could. They also need to travel a quarter of the way around the world without refuelling. This means that they need to carry a lot of fuel, which can be over a third of the total weight of the plane! The planes themselves are necessarily larger, too, which further increases the weight to be carried.

#### Lift

In level flight, lift is produced by pressure differences produced by airflow across the wings, with lift depending on the speed and on the surface area of the wings. Cruising speeds of many jet aircraft are all rather similar, being just less than the speed of sound, so differences in lift are likely to depend mainly on the surface area and shape of the wings.

#### Take-off

Aircraft use fuel very rapidly at take-off, when the engines have to deliver maximum thrust. The aircraft must accelerate fast enough to reach the speed needed to take off, usually about  $240 - 290 \text{ km h}^{-1}$  ( $150 - 180 \text{ miles h}^{-1}$ ) in a distance well within the length of the runways available. Because take-off speeds and runway lengths are all rather similar, the acceleration of most jet aircraft down the runway is similar, whatever their mass and total engine thrust.

After take-off, jet aircraft are required to climb steeply to avoid excessive noise nuisance. If the angles of climb are similar, this also requires maximum thrust to be related to total aircraft take-off weight.

Data on six aircraft are given in the table of Fig. 6 opposite.

type	number of engines	maximum thrust per engine / kN	maximum take-off mass /kg	take-off distance /m	cruising speed km/h	fuel consumption litre/h	fuel capacity /litre	range /km	wing surface area /m <sup>2</sup>
Airbus A340-300	4	152	284 000	3400	876	8000	155 400	13 500	362
Airbus A340-600	4	276	365 000	3200	902	9800	195 600	13 900	437
Boeing 777-200	2	343	247 000	3100	900	7700	117 300	9000	430
Boeing 747-400	4	264	397 000	3600	925	14 160	216 800	13 500	525
DC10-40	3	236	251 700	2800	965	10 800	138 700	9300	339
MD-11	3	270	273 900	3100	945	9000	146 000	12 600	339

Fig. 6

END OF ARTICLE





**Copyright Information**

OCR is committed to seeking permission to reproduce all third-party content that it uses in its assessment materials. OCR has attempted to identify and contact all copyright holders whose work is used in this paper. To avoid the issue of disclosure of answer-related information to candidates, all copyright acknowledgements are reproduced in the OCR Copyright Acknowledgements Booklet. This is produced for each series of examinations, is given to all schools that receive assessment material and is freely available to download from our public website ([www.ocr.org.uk](http://www.ocr.org.uk)) after the live examination series.

If OCR has unwittingly failed to correctly acknowledge or clear any third-party content in this assessment material, OCR will be happy to correct its mistake at the earliest possible opportunity.

For queries or further information please contact the Copyright Team, First Floor, 9 Hills Road, Cambridge CB2 1GE.

OCR is part of the Cambridge Assessment Group; Cambridge Assessment is the brand name of University of Cambridge Local Examinations Syndicate (UCLES), which is itself a department of the University of Cambridge.