

Physics A

Unit: G482: Electrons, Waves and Photons

1(a) Name the charge carriers responsible for electric current in a metal and in an electrolyte.	
[2]	
<i>Candidate style answer</i>	<i>Examiners commentary</i>
<i>Electrons are the charged particles in a metal and protons in an electrolyte.</i>	Part(a) only scores one mark as the candidate has muddled protons and ions.

(b)(i) Define electrical resistivity.	
[2]	
<i>Candidate style answer</i>	<i>Examiners commentary</i>
<i>The electrical resistivity of a substance is the resistance of a unit cube of it...</i>	Part(b)(i) scores zero as this is not the definition.

(ii) Explain why the resistivity rather than the resistance of a material is given in tables of properties of materials.	
[1]	
<i>Candidate style answer</i>	<i>Examiners commentary</i>
<i>Each resistor may have a different shape and size giving it a different value but the resistivity is always the same</i>	part (ii) gains the mark with a b.o.d. (benefit of the doubt) as the key idea of dimensions is included.

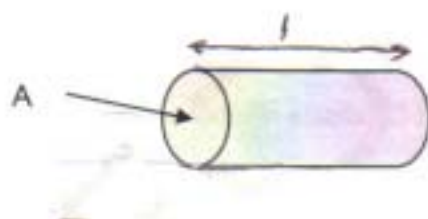

Fig. 1.1

(c) Fig. 1.1. shows a copper rod of length $l = 0.080\text{m}$, having a cross-sectional area $A = 3.0 \times 10^{-4} \text{m}^2$.

The resistivity of copper is $1.7 \times 10^{-8} \Omega \text{m}$.

(i) Calculate the resistance between the ends of the copper rod.

[2]

<i>Candidate style answer</i>	<i>Examiners commentary</i>
$R = \rho l/A$ $= 1.7 \times 10^{-8} \times 0.08/3.0 \times 10^{-4}$ $= 4.53 \times 10^{-6}$ Resistance = 4.5×10^{-6} ... Ω	Part(c) (i) shows that the candidate is aware of the defining equation but no retrospective mark for (b)(i) should be considered. One mark is for correct substitution of the figures and one for the correct answer.

(ii) The copper rod is used to transmit large currents. A charge of 650 C passes along the rod every 5.0 s. Calculate

1 the current in the rod [2]

Candidate style answer	Examiners commentary
$I = Q/t$ $= 650/5$ <i>current = 130.....A</i>	Part(c)(ii) is a U grade question where just the answer with no working will score both marks. There is no ambiguity so the candidate can only have arrived at the answer by the correct calculation. However it is recommended that the candidate shows working to gain credit if the calculation is performed incorrectly.

2 the total number of electrons passing any point in the rod per second. [2]

[Total:11]

Candidate style answer	Examiners commentary
<i>number = 8.1×10^{20}.....</i>	

Comments: The candidate gained 8/11 marks for this first question. The question is typical of an opening question to help candidates settle into the examination. It relies on recall of basic facts and definitions and simple calculations.

2(a) (i) Use energy considerations to distinguish between potential difference (p.d.) and electromotive force (e.m.f.). [2]

Candidate style answer	Examiners commentary
<i>The potential difference across a resistor is the energy heating it when 1 coulomb of charge passes. The e.m.f. is the energy given to each coulomb of charge moving round the circuit by the battery...</i>	In part (a) (i) the examiner is looking for <i>per unit charge</i> or equivalent. As written this candidate could mean $V = EQ$ or $V = E/Q$. As the same ambiguity occurs twice the penalty is just one mark.

(ii) Here is a list of possible units for e.m.f. or p.d.

$J s^{-1}$ $J A^{-1}$ $J C^{-1}$

State which one is a correct unit: [1]

Candidate style answer	Examiners commentary
$J C^{-1}$	Part (a) (ii) is correct.

(b) Kirchoff's second law is based on the conservation of a quantity. State the law and the quantity that is conserved. [2]

Candidate style answer	Examiners commentary
<p>The e.m.f. of the battery is equal to the sum of potential differences across all of the components in the circuit. Charge is conserved.</p>	<p>In part (b) the statement of Kirchoff's second law is considered to be good enough but the wrong quantity is conserved. Charge is the conserved quantity for the first law.</p>

(c) A battery is being tested. Fig. 2.1 shows the battery connected to a variable resistor R and two meters.

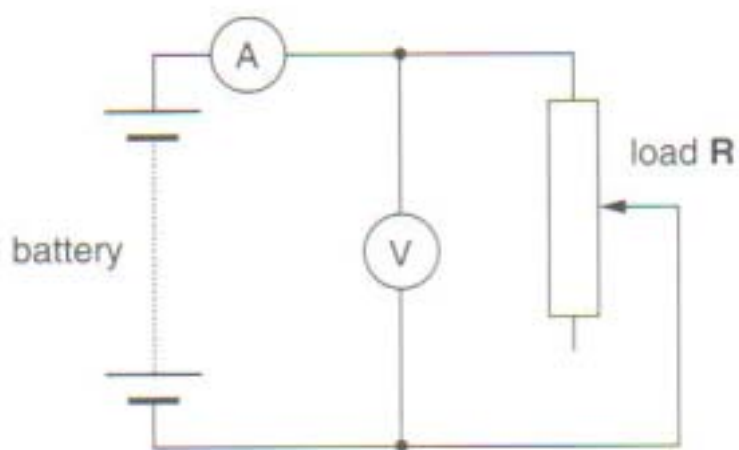

Fig. 2.1

The graph of Fig.2.2 shows the variation of the p.d. V across the battery with the current I as R is varied.

(i) Draw the line of best fit on Fig. 2.2. [1]

Candidate style answer	Examiners commentary
<p>The graph shows potential difference (p.d.) in Volts (V) on the y-axis and current in Amperes (A) on the x-axis. The y-axis ranges from 0.0 to 7.0 with major grid lines every 1.0 and minor grid lines every 0.2. The x-axis ranges from 0 to 2.5 with major grid lines every 0.5 and minor grid lines every 0.1. A straight line of best fit is drawn through the data points, starting at approximately (0, 6.1) and ending at (2.0, 0.0). The data points are approximately at (0.2, 5.5), (0.5, 4.5), (1.0, 3.0), (1.5, 1.5), and (2.0, 0.0). A point 'M' is marked on the line at approximately (0.7, 4.5).</p>	<p>In part (c) the straight line is adequate and the intercept with the y-axis could be 6.1. However there is no initial discussion or algebraic formula given for the internal resistance so one mark is lost.</p>

Fig. 2.2

(ii) Use your line of best fit to determine
the e.m.f. \mathcal{E} of the battery
the internal resistance r of the battery. Show your working clearly. [3]

Candidate style answer	Examiners commentary
$\mathcal{E} = \dots\dots 6.1 \dots\dots V$ $r = (6.1 - 0)/2.0$ $r = \dots\dots 3.05 \dots\dots \Omega$	

(d) The variable resistor R is adjusted to give the values at point M on Fig. 2.2.
Calculate
(i) the resistance of R at this point [3]

Candidate style answer	Examiners commentary
At point M, $I = 0.6 A$ and $V = 4.3 V$ $R = V/I = 4.3/0.6$ $R = \dots\dots 7.2 \dots\dots \Omega$	In part (d) the candidate takes the value of the p.d. on the line rather than at M so loses one mark but the remainder of the question is correct. With <i>error carried forward</i> applied the candidate just loses one mark.

(ii) the power dissipated in R. [2]
[Total: 15]

Candidate style answer	Examiners commentary
$P = IV = 0.6 \times 4.3 = 2.58$ power = $\dots\dots 2.6 \dots\dots W$	

Comments: The candidate scores 11/15 for this question.

3 Fig. 3.1 shows how the resistance of a thermistor varies with temperature.

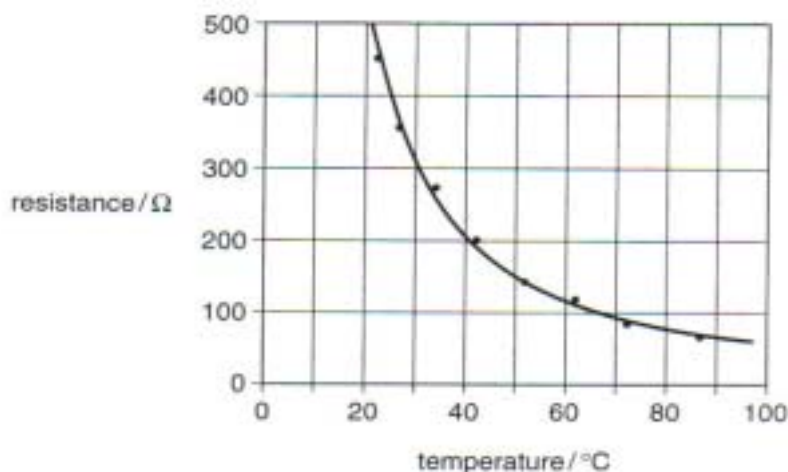

Fig. 3.1

(a) (i) Describe qualitatively how the resistance of the thermistor changes as the temperature rises.

[1]

Candidate style answer

Examiners commentary

the resistance decreases.

(ii) The change in resistance between 80 $^{\circ}\text{C}$ and 90 $^{\circ}\text{C}$ is about 15 Ω .

State the change in resistance between 30 $^{\circ}\text{C}$ and 40 $^{\circ}\text{C}$.

[1]

Candidate style answer

Examiners commentary

105 Ω ...

(iii) Describe, giving a reason, how the sensitivity of temperature measurement using this circuit changes over the range of temperatures shown on Fig. 3.1.

[2]

Candidate style answer

Examiners commentary

Near room temperature the change in resistance is large but at much higher temperatures it is small...

Part(a)(iii) was just enough to gain a mark although there was no reference to equal increments of temperature for each change in resistance.

(b) Fig 3.2 shows a temperature sensing potential divider circuit where this thermistor may be connected, between terminals A and B, in series with a resistor.

(i) Draw the circuit symbol for a thermistor on Fig. 3.2 in the space between terminals **A** and **B**. [1]

(ii) A voltmeter is to be connected to the circuit to indicate an increasing p.d. when the thermistor detects an increasing temperature. On Fig. 3.2, draw the circuit connections for a voltmeter to measure a p.d. that rises with increasing temperature. [1]

Candidate style answer

Examiners commentary

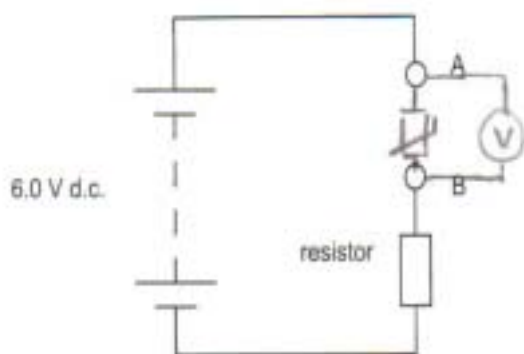

Fig. 3.2

In part (b)(ii) the voltmeter was placed incorrectly and in

(iii) The value of the resistor in Fig. 3.2 is 200 Ω. The thermistor is at 65 °C. Use data from Fig. 3.1 to show that the current in the circuit is about 0.02 A. [3]

Candidate style answer

Examiners commentary

*the thermistor resistance is 105 Ω so the total resistance is $R = 305 \Omega$
 $I = V/R = 6/305 = 0.02 \text{ A}$*

(iii) the candidate loses one mark for not showing how 0.02 was achieved. The mark would have been given for 0.0197 or 0.020 indicating that the calculation was actually done.

(iv) Calculate the p.d. across the 200 Ω resistor at 65 °C. [1]

Candidate style answer

Examiners commentary

*$V = 0.02 \times 200$
 p.d. across resistor =4.0.....V*

(c) The graphs X, Y and Z in Fig 3.3. show how the p.d. across the resistor varies with temperature, for three different values of the resistor.

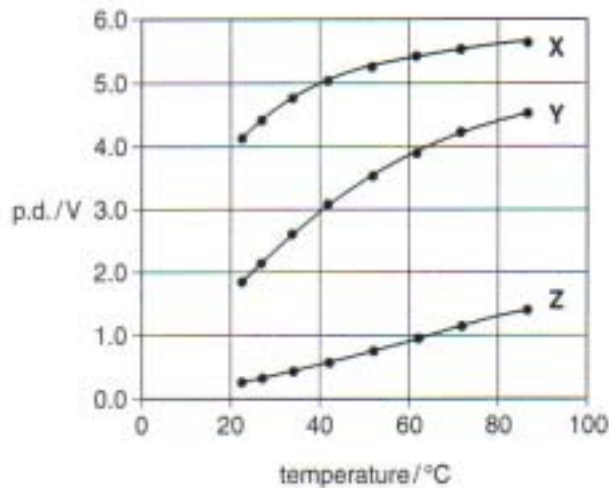

Fig. 3.3

(i) The values of resistance used are 20 Ω , 200 Ω and 1000 Ω .

State, explaining your reasoning clearly, which graph, X, Y or Z, is the curve for the 1000 Ω resistor.

[2]

Candidate style answer	Examiners commentary
At 20°C the resistance of the thermistor is 500 Ω . As the resistor is 1000 Ω a ratio of 4 V to 2 V is needed with the bigger voltage across the resistor so X is the graph.	

(ii) State one advantage and one disadvantage of using output Z for the temperature sensing circuit.

[2]

[Total: 14]

Candidate style answer	Examiners commentary
<p>advantage .the change in resistance and the change in resistance are almost proportional</p> <p>disadvantage the values of potential difference are too small</p>	In part (c)(ii) the first marking point was given with a b.o.d. although the line is not drawn to the origin. The second point made was equally if not more vague; the range of p.d.s is too small would have been adequate. The second mark was not given.

Comments: The candidate scored 10/14 for this question.

4(a) Fig.4.1 shows the electromagnetic spectrum.

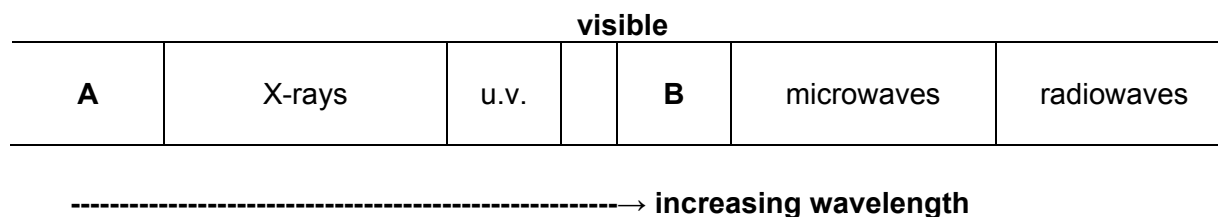

In the spaces in Fig. 4.2, identify the principal radiations A and B and for each suggest a typical value for the wavelength.

[4]

<i>Candidate style answer</i>			<i>Examiners commentary</i>
	principal radiation	λ/m	In part (a) the wavelength of gamma rays is outside the range losing one mark.
A	<i>gamma-rays</i>	10^{-9}	
B	<i>infra-red</i>	10^{-6}	

Fig. 4.2

(b) State two features common to all types of radiation in the electromagnetic spectrum.

[2]

<i>Candidate style answer</i>	<i>Examiners commentary</i>
<i>They can travel through a vacuum and they can be polarised.</i>	

(c) (i) Define the term *plane-polarisation* of visible light waves.

[1]

<i>Candidate style answer</i>	<i>Examiners commentary</i>
<i>The light wave can only exist in one plane.</i>	In part (c)(i) the answer is too vague or ambiguous to earn the mark

(ii) Explain why sound waves cannot be *plane-polarised*.

[2]

<i>Candidate style answer</i>	<i>Examiners commentary</i>
<i>Sound waves are longitudinal waves so cannot be polarised.</i>	(ii) lacks sufficient detail to be worthy of more than 1 mark.

(d) Fig. 4.3 shows a student observing a parallel beam of plane-polarised light that has passed through a polarising filter.

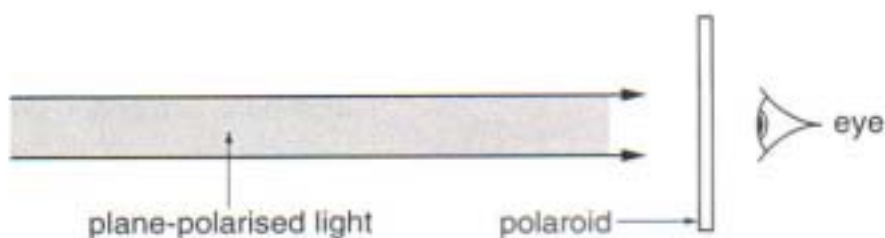

Fig. 4.3

(i) Fig. 4.4. shows how the intensity of the light reaching the student varies as the polarising filter is rotated through 360° in its own plane.

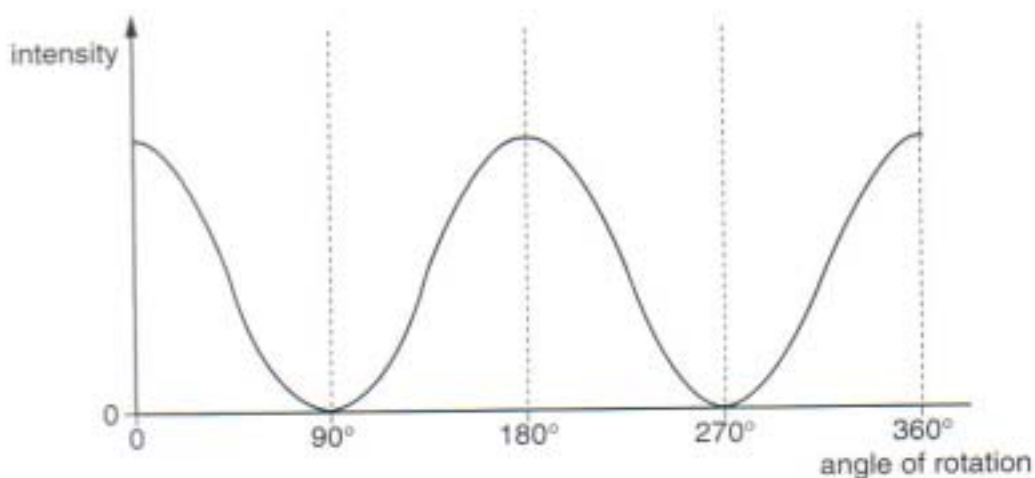

Fig. 4.4

Suggest why there is a series of maxima and minima in the intensity.

[2]

Candidate style answer	Examiners commentary
<i>The polarising filter cuts out the light completely at one angle of rotation but lets it through at 90° to this angle.</i>	The same comment is true for part (d)(i).

(ii) Hence explain how sunglasses using polarising filters reduce glare.

[2]

Candidate style answer	Examiners commentary

(e) State an example of plane-polarisation that does not involve visible light and state how the polarised wave may be detected.

[2]

[Total: 15]

Candidate style answer	Examiners commentary
<i>Microwaves can be polarised. Dish aerials can be used to detect microwaves</i>	Part (e) fails to score any marks because there is no context to relate the wave to polarisation. Some statement about the rotation of the transmitter and or receiver of the 3 cm wave

	apparatus commonly available in the school laboratory would have scored both marks.
--	---

Comments: The candidate showed that his knowledge of this subject is limited. The answers lack detail. In fact there is no attempt at part (d)(ii). The score is 7/15.

5(a) State and explain one difference between a progressive and a standing wave. [2]

Candidate style answer	Examiners commentary
<i>The amplitude of a progressive wave is the same along the wave but a standing wave has places where the amplitude is always zero called nodes</i>	Part (a) gains both marks as a valid quantity chosen and a comparison given.

(b) In an investigation of standing waves, a loudspeaker is positioned above a long pipe containing water, causing sound waves to be sent down the pipe. The waves are reflected by the water surface. The water level is lowered until a standing wave is set up in the air in the pipe as shown in Fig. 5.1. A loud note is heard. The water level is then lowered further until a loud sound is again obtained from the air in the pipe. See Fig. 5.2.

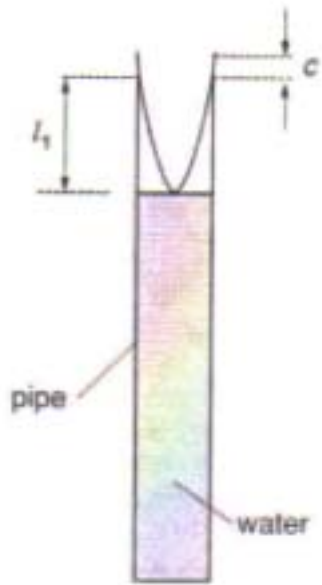

Fig 5.1

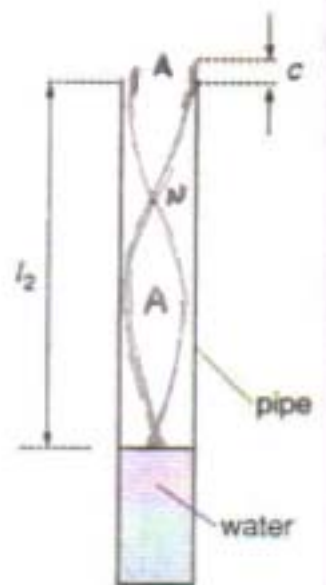

Fig. 5.2

The air at the open end of the pipe is free to move and this means that the antinode of the standing wave is actually a small distance c beyond the open end. This distance is called the end correction.

A student writes down the following equations relating the two situations shown.

$$l_1 + c = \lambda/4 \quad l_2 + c = 3\lambda/4$$

(i) Draw the standing wave in the pipe shown in Fig. 5.2 which corresponds to the equation $l_2 + c = 3\lambda/4$.

[1]

(ii) On your diagram, label the positions of any displacement nodes and antinodes with

<p>the letters N and A respectively.</p>		[1]
<p>Candidate style answer</p>	<p>Examiners commentary</p>	
	<p>In part (b) the sketch is correct but the bottom N is forgotten at the water level losing one mark.</p>	
<p>(iii) Use the two equations to show that $l_2 - l_1 = \lambda/2$.</p>		
		[1]
<p>Candidate style answer</p>	<p>Examiners commentary</p>	
<p>$l_2 + c - (l_1 + c) = 3\lambda/4 - \lambda/4$ giving $l_2 - l_1 = \lambda/2$</p>		
<p>(iv) The following results were obtained in the experiment.</p> <p>frequency of sound = 500Hz $l_1 = 0.170$ m $l_2 = 0.506$ m</p> <p>Calculate the speed of sound in the pipe.</p>		
		[3]
<p>Candidate style answer</p>	<p>Examiners commentary</p>	
<p>$\lambda/2 = 0.506 - 0.170$ $\lambda = 0.67$ m speed =340..... $m s^{-1}$</p>	<p>In (iv) there is no working. Either the figure 500 x 0.67 or the fuller answer of 335 must be shown for the third mark.</p>	
<p>(c) The student repeats the experiment, but sets the frequency of the sound from the speaker at 5000 Hz.</p> <p>Suggest and explain why these results are likely to give a far less accurate value for the speed of sound than those obtained in the first experiment.</p> <p><i>In your answer, you should make clear the sequence of steps in your argument.</i></p>		
		[4]
		[Total: 12]
<p>Candidate style answer</p>	<p>Examiners commentary</p>	

At a higher frequency the wavelength of the standing wave in the tube will be smaller so it will be more difficult to measure and the calculation of the speed will be less accurate.	In part (c) it is the measurement that is less accurate rather than being more difficult so the candidate has missed the point – given 2/4 for recognising smaller wavelength and smaller distances to measure.
---	---

Comments: The candidate scores 8/12.

6(a) Explain what is meant by the principle of superposition of two waves. [2]

Candidate style answer	Examiners commentary
When two waves meet they add together to give a new wave with a bigger amplitude	In part (a) the mark is for the waves meeting.

(b) In an experiment to try to produce an observable interference pattern, two monochromatic light sources, S_1 and S_2 , are placed in front of a screen, as shown in Fig. 6.1.

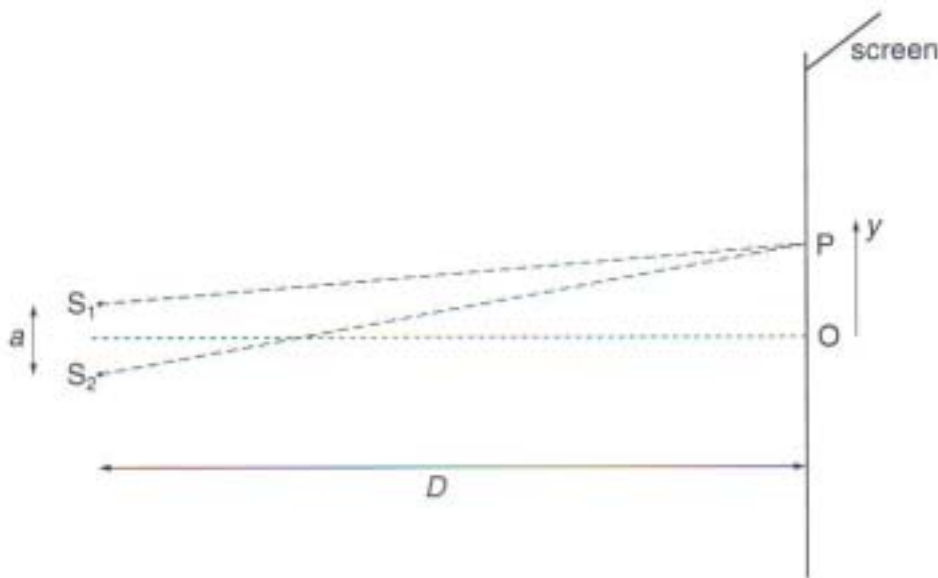

Fig. 6.1.

(i) In order to produce a clear interference pattern on the screen, the light sources must be *coherent*. State what is meant by *coherent*. [2]

Candidate style answer	Examiners commentary
They are always in phase	In part (b)(i) the candidate focuses on phase but not in sufficient detail so again scores one mark.

(ii) In Fig 6.1, the central point O is a point of maximum intensity. Point P is the position of minimum intensity nearest to O. State, in terms of the wavelength λ , the magnitude of the path difference S_1P and S_2P . [1]

Candidate style answer	Examiners commentary
$\lambda/2$.	

(c) In another experiment, a beam of laser light of wavelength $6.4 \times 10^{-7} \text{ m}$ is incident on a double slit which acts as the two sources in Fig. 6.1.

(i) Calculate the slit separation a , given that the distance D to the screen is 1.5 m and the distance between P and O is 4.0 mm.

[3]

Candidate style answer	Examiners commentary
<p>using $\lambda = a\alpha/D$ $a = \lambda D/\alpha$ so $a = 6.4 \times 10^{-7} \times 1.5/4.0 \times 10^{-3}$</p> <p>$a = \dots\dots 2.4 \times 10^{-4} \text{ m}$</p>	<p>In part (c) the candidate thinks that the fringe width x in the formula is from maximum to minimum so loses one mark in (i) and despite the possibility of error carried forward</p>

(ii) Sketch on the axes of Fig. 6.2 the variation of the intensity of the light on the screen with distance y from O.

[1]

[Total:10]

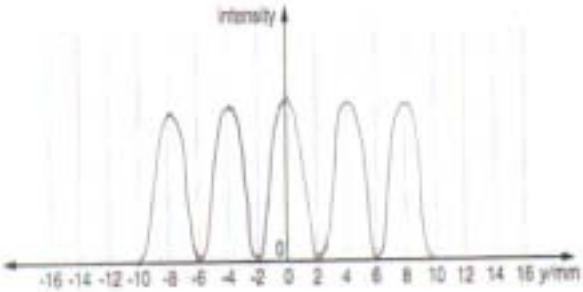
Candidate style answer	Examiners commentary
 <p style="text-align: center;">Fig. 6.2</p>	<p>gains no marks in (ii) because (b)(ii) and (c)(i) give the information that the first minimum is at 4.0 mm</p>

Comments: This is an example of a question which should take the candidate a shorter time to answer because there is a sketch, a simple calculation to complete and relatively little writing to do.

The candidate scores 5/10.

7(a) The concept of the photon was important in the development of physics throughout the last century. Explain what is meant by a photon.

[1]

Candidate style answer	Examiners commentary
<p>A photon is a packet of light energy..</p>	<p>All three marks awarded for parts(a) and (b)(i);</p>

(b) A laser emits a short pulse of ultraviolet radiation. The energy of each photon in the beam is $5.60 \times 10^{-19} \text{ J}$.

(i) Calculate the frequency of an ultraviolet photon of the laser light.

[2]

Candidate style answer	Examiners commentary
<p>$E = hf$ so $f = 5.60 \times 10^{-19} / 6.63 \times 10^{-34}$</p> <p>frequency = $8.45 \times 10^{14} \text{ Hz}$</p>	<p>All three marks awarded for parts(a) and (b)(i);</p>

(ii) A photon of the laser light strikes the clean surface of a sheet of metal. This causes an electron to be emitted from the metal surface.	
1 The work function energy of the metal is 4.80×10^{-19} J. Define the term work function energy.	
[1]	
<i>Candidate style answer</i>	<i>Examiners commentary</i>
	no knowledge of the p.e. effect shown in (b)(ii).

2 Show that the maximum kinetic energy of the emitted electron is 8.0×10^{-20} J.	
[1]	
<i>Candidate style answer</i>	<i>Examiners commentary</i>

(iii) Show that the maximum speed of emission of an electron is about 4×10^5 m s⁻¹.	
[2]	
<i>Candidate style answer</i>	<i>Examiners commentary</i>
$k.e = \frac{1}{2}mv^2$ $8.0 \times 10^{-20} = \frac{1}{2}(9.1 \times 10^{-31})v^2$ $v^2 = 16 \times 10^{-20} / 9.1 \times 10^{-31}$ $v = 4.2 \times 10^5 \text{ m s}^{-1}$	Part (b) (iii) has been completed by using the figures given in the stem of the question and this time working has been shown to score both marks.

(c) (i) State the de Broglie equation. Define any symbols used.	
[2]	
<i>Candidate style answer</i>	<i>Examiners commentary</i>
$\lambda = h/mv.$	The candidate has chosen the correct equation from the data sheet so scores one easy mark in part (c)(i) but fails to identify the symbols or go on to do any calculation.

(ii) Calculate the minimum de Broglie wavelength associated with an electron emitted in (b) above.	
[2]	
[Total: 11]	
<i>Candidate style answer</i>	<i>Examiners commentary</i>

Comments: The candidate has scored 6/11 on this question. Either he/she decided to attempt the last question first of short of time or else this is an area of the specification where knowledge is weak.

8 The concept of energy is important in many branches of physics. Energy is usually measured in joules, but sometimes the <i>kilowatt-hour</i> (kW h) and the <i>electron volt</i> (eV) are more convenient units of energy.
Define the <i>kilowatt-hour</i> and the <i>electron volt</i> and determine their values in joules.

Suggest why the *kilowatt-hour* and *electron volt* may be more convenient than joules.

 In your answer you should make clear how your suggestions link with the evidence.

Illustrate your answer by determining the energy dissipated by a 100 W filament lamp left on for 12 hours and the kinetic energy of an electron accelerated through a p.d. of 1.0 MV in a particle accelerator.

[12]

Paper Total [100]

Candidate style answer	Examiners commentary
<p><i>1 kW h is a unit of energy. It is equal to 3.6×10^6 J.</i></p> <p><i>1 eV is the energy given to an electron when it is accelerated through a potential difference of 1 V. It is equal to 1.6×10^{-19} J.</i></p> <p><i>The kilowatt-hour is the unit used on home electricity bills.</i></p> <p><i>If a 100 W lamp is left on for 12 hours then it uses 1.2 kW h of electricity using the formula $E = Pt$. This is 4.3×10^6 J of electrical energy.</i></p>	<p>The candidate scores a total of 6/12 for this question. It appears that he/she has not stopped to read the question properly and has just picked a few sentences on which to base an answer. The answer is also very short possibly indicating a lack of time. The quality of written communication mark has not been awarded although what has been written is to the point and is correct.</p> <p>The first line gains 1 mark for the value of 1 kW h; The second and third lines 2 marks. The use of the kW h gains 1 mark and the final paragraph 2 marks.</p> <p>The candidate has scored a mark 60/100 on the unit.</p> <p>The candidate has thrown away a number of marks and with a little more forethought could have achieved a better grade. The paper shows promise and with further experience and application this candidate could progress to a high grade at A2 level.</p>