

OXFORD CAMBRIDGE AND RSA EXAMINATIONS

Advanced GCE

PHYSICS A

2826/03/TEST

Practical Examination 2 (Part B – Practical Test)

Wednesday

25 MAY 2005

Morning

1 hour 30 minutes

Candidates answer on the question paper.

Additional materials:

Candidate's Plan (Part A of the Practical Examination)

Electronic Calculator

Candidate Name	Centre Number	Candidate Number												
	<table border="1" style="display: inline-table; border-collapse: collapse;"> <tr> <td style="width: 15px; height: 15px;"></td> <td style="width: 15px; height: 15px;"></td> <td style="width: 15px; height: 15px;"></td> <td style="width: 15px; height: 15px;"></td> <td style="width: 15px; height: 15px;"></td> <td style="width: 15px; height: 15px;"></td> </tr> </table>							<table border="1" style="display: inline-table; border-collapse: collapse;"> <tr> <td style="width: 15px; height: 15px;"></td> <td style="width: 15px; height: 15px;"></td> <td style="width: 15px; height: 15px;"></td> <td style="width: 15px; height: 15px;"></td> <td style="width: 15px; height: 15px;"></td> <td style="width: 15px; height: 15px;"></td> </tr> </table>						

TIME 1 hour 30 minutes

INSTRUCTIONS TO CANDIDATES

- Write your name in the space above.
- Write your Centre number and Candidate number in the boxes above.
- Answer **all** the questions.
- Write your answers in the spaces provided on the question paper.
- Read the instructions and questions carefully.

INFORMATION FOR CANDIDATES

- In the Practical Test you will be assessed on the Experimental and Investigative Skills:
 - Skill I Implementing
 - Skill A Analysing evidence and drawing conclusions
 - Skill E Evaluating evidence and procedures.
- You may use an electronic calculator.
- You are advised to show all the steps in any calculations.
- You will be awarded marks for the quality of written communication where this is indicated in the question.

FOR EXAMINER'S USE		
Qu.	Max.	Mark
Planning	16	
1	28	
2	16	
TOTAL	60	

This question paper consists of 10 printed pages and 2 blank pages.

Answer all the questions.

It is recommended that you spend about 1 hour on this question.

- 1 In this experiment you will use moments to investigate how the force required to pull a bar magnet away from a metal plate varies as the number of sheets of paper separating the magnet and the plate is changed.
- (a) (i) You are supplied with a nail which has been pushed into a cork and a metre rule with a small hole drilled at the centre. Mount the cork and nail using the stand, boss and clamp so that the nail is horizontal. Place the rule onto the nail. You may need to attach a small piece of blutack to the rule to obtain horizontal equilibrium. Do not spend too much time in trying to achieve a perfect balance.
- (ii) Suspend the bar magnet on the left-hand side of the rule 25 cm from the pivot and a load M on the right-hand side of the rule using small loops of string. Adjust the position of M so that the rule is again in horizontal equilibrium. Adjust the position of the boss so that the lower end of the magnet is a few centimetres above the bench. The arrangement should now be as shown in Fig. 1.1.

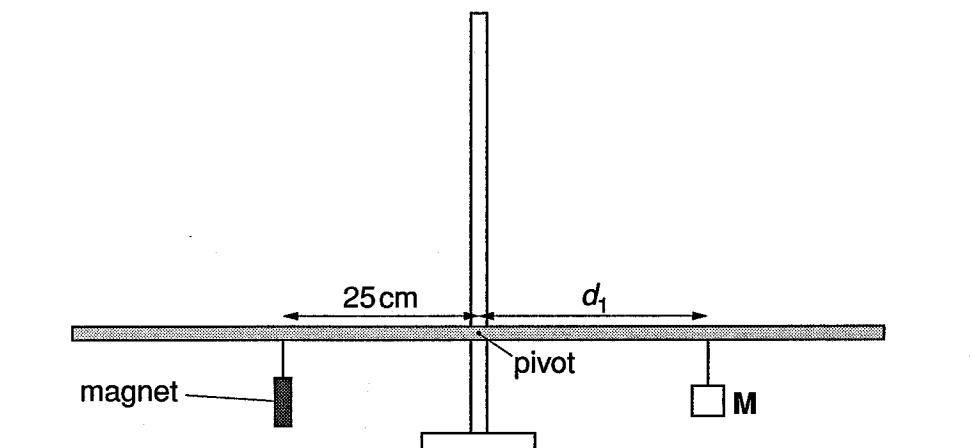

Fig. 1.1

Measure and record the distance d_1 of M from the pivot.

distance $d_1 = \dots\dots\dots$ cm

- (iii) The mass m of M is written on a card. Use the principle of moments to determine a value for the weight W of the magnet. You may assume that the value of the gravitational field strength $g = 9.81 \text{ N kg}^{-1}$.

$W = \dots\dots\dots$ N [2]

- (b) (i) Position the metal plate below the magnet. Place 20 sheets of paper onto the plate. Tilt the rule so that the magnet is in contact with the top sheet of paper. Adjust the height of the boss so that the rule is again approximately horizontal. The arrangement should now be as shown in Fig. 1.2.

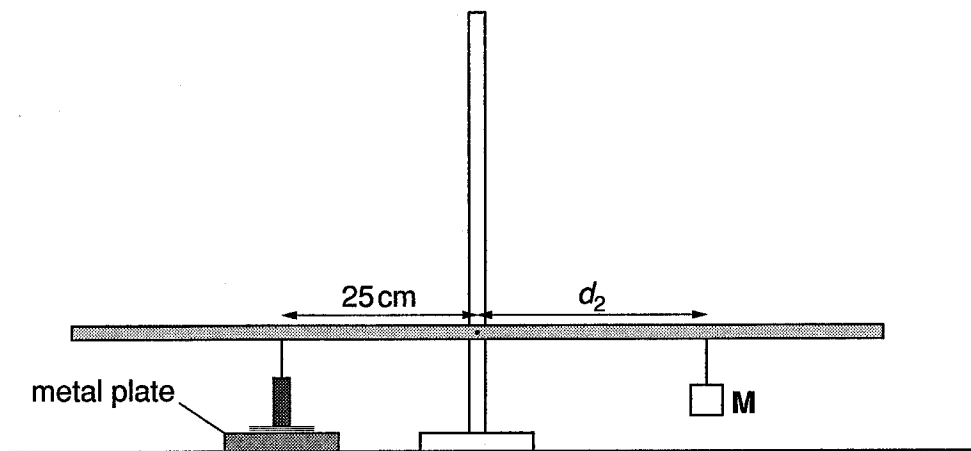

Fig 1.2

- (ii) Place some padding under the right hand side of the rule. Move **M** in small steps towards the right-hand end of the rule until a position is found where the upward force on the bar magnet is just sufficient to pull it away from the metal plate. Measure and record the distance d_2 in cm of **M** from the pivot.

$d_2 = \dots\dots\dots$ cm [1]

- (iii) Estimate the percentage uncertainty in d_2 .

percentage uncertainty in $d_2 = \dots\dots\dots$ [1]

- (iv) Briefly explain how you made the measurement of d_2 as accurate as possible.

.....

 [1]

(c) A theoretical treatment of the turning forces on the rule leads to the expression

$$25(W + F) = d_2 mg$$

where F is the force of attraction between the magnet and the metal plate. Use the results of your experiment to find a value for F .

$F = \dots\dots\dots$ N [2]

(d) Change n , the number of paper sheets, on the metal plate. Tilt the rule so that the magnet is in contact with the top sheet of paper again. If necessary adjust the boss to ensure that the rule remains approximately horizontal. Repeat (b) (ii) and (c) until you have six sets of readings for F and n . Values of n should be in the range $10 \leq n \leq 40$.

[7]

- (e) (i) Plot a graph of F/N (y -axis) against n (x -axis).
- (ii) Draw a smooth curve through the points.
- (iii) Determine the rate of change of F with n when $n = 20$.

rate of change of F with $n = \dots\dots\dots$ N [8]

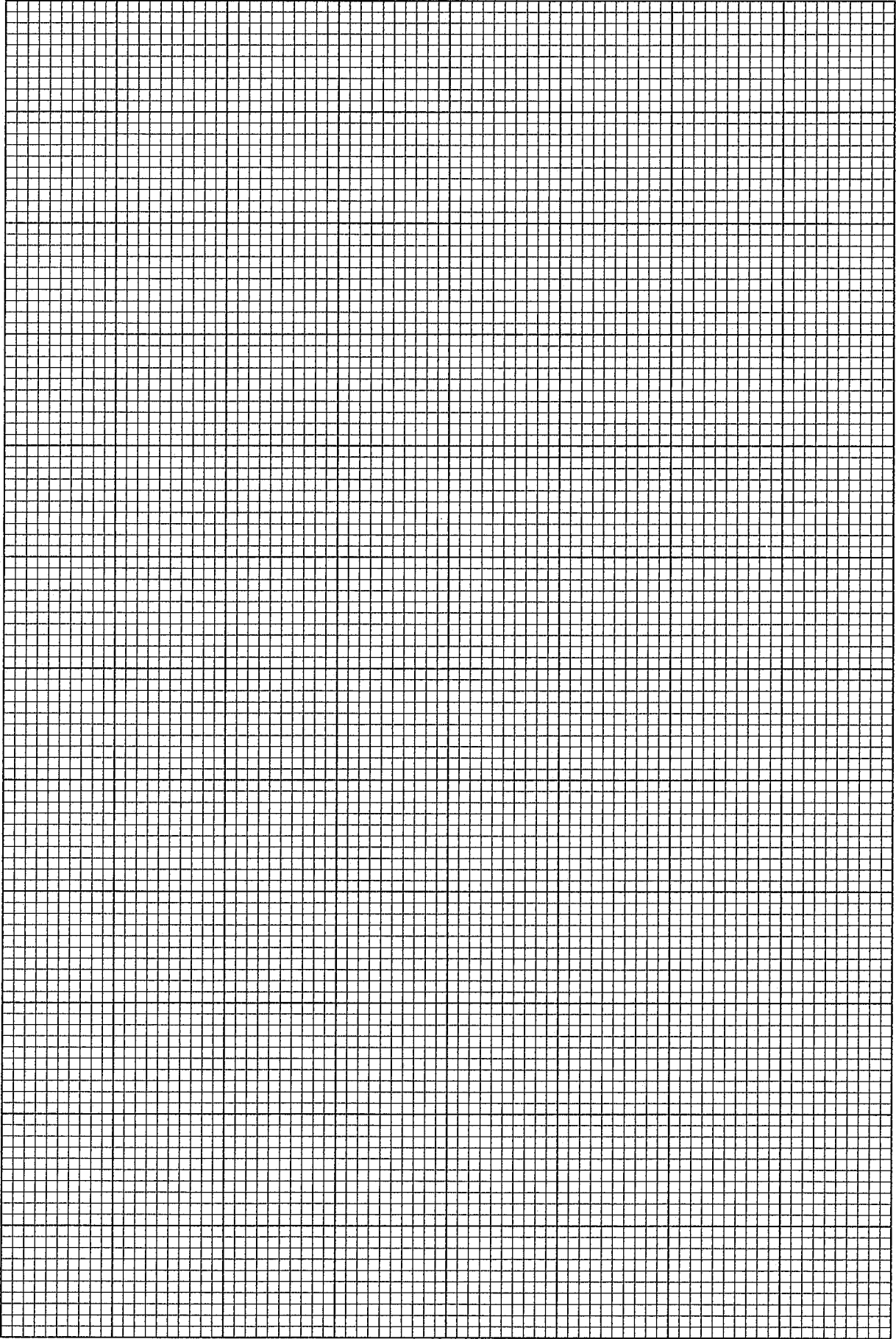

- (f) A student looking at the graph of the results of this experiment suggests that F and n may be related exponentially by an expression of the form

$$F = Ae^{-Bn}$$

where A and B are unknown constants.

- (i) Suggest what graph may be plotted to verify this relationship.

.....

 [1]

- (ii) State how A and B would be found from the graph.

.....

 [2]

- (g) (i) Measure and record the thickness of 40 sheets of paper using a micrometer screw gauge. You may need to ask your Supervisor to supply you with a micrometer screw gauge when you are ready to make this measurement.

thickness of 40 sheets of paper = mm [1]

- (ii) Without further measurement and using the results of your experiment, determine a value for F when the separation of the magnet and the metal plate is 3.0 mm.

$F =$ N [2]

[Total: 28]

It is recommended that you spend about 30 minutes on this question.

Approximately half of this time should be spent on the evaluation exercise in part (d).

2 In this experiment you will investigate the torsional oscillations of a suspended metre rule.

A metre rule has been suspended horizontally from another metre rule by two vertical threads. The length l of each of the threads is 50.0 cm.

(a) (i) Adjust the separation d of the threads so d is 20.0 cm, ensuring that the threads are equidistant from the ends of the rules. The arrangement is shown in Fig. 2.1.

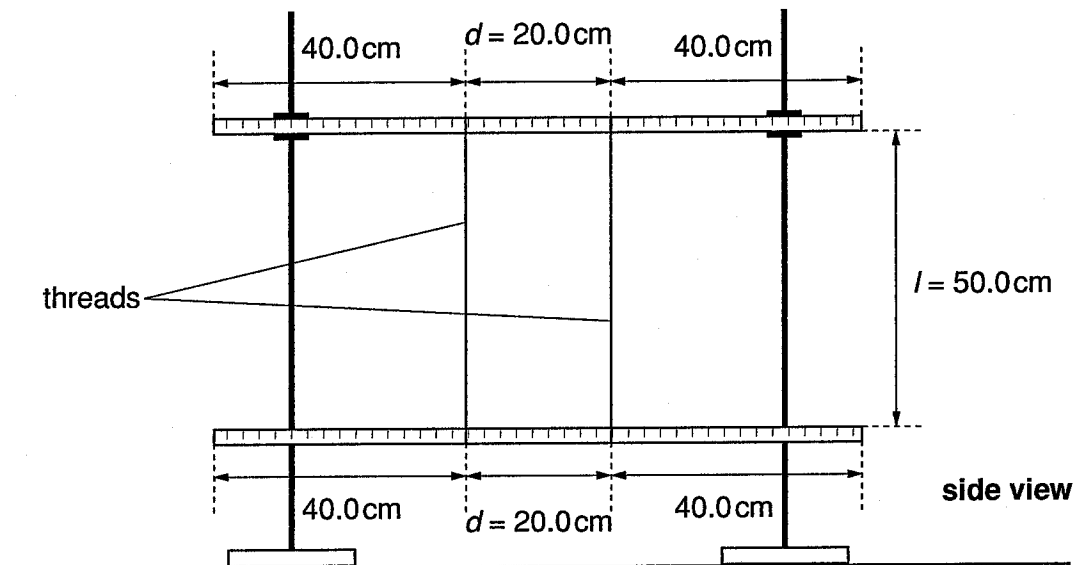

Fig. 2.1

(ii) Displace the ends of the lower rule slightly so that it performs small torsional oscillations about a vertical axis through the centre of the rule as shown in Fig. 2.2.

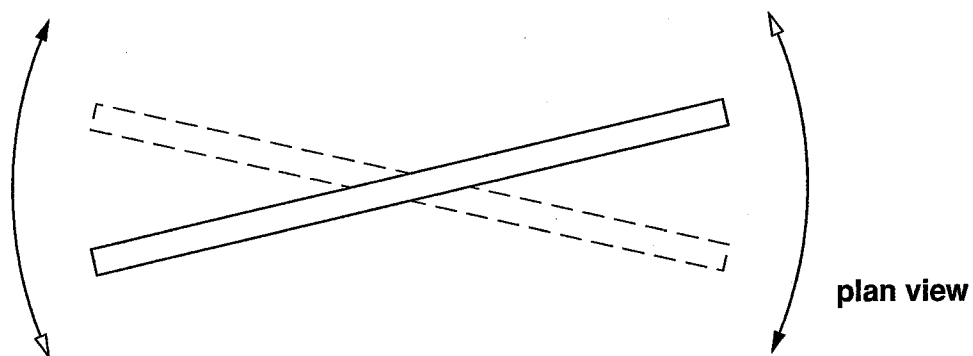

Fig. 2.2



- (iii) Make and record measurements in order to determine the period T of these oscillations.

$T = \dots\dots\dots$ s [1]

- (iv) Justify the number of significant figures that you have given for T .

.....

[1]

- (b) Increase the value of d to 40.0 cm, ensuring that the threads are still equidistant from the ends of the rule. Repeat parts (a) (ii) and (a) (iii) to give a new value for the period of torsional oscillation of the rule.

$T = \dots\dots\dots$ s [2]

- (c) It is suggested that T is inversely proportional to d . Do the results of your experiment support this suggestion? Justify your answer.

.....

[2]

BLANK PAGE

BLANK PAGE

OCR has made every effort to trace the copyright holders of items used in this Question paper, but if we have inadvertently overlooked any, we apologise.